

# **H** TECHNICAL PROCEDURE

## **STEERTEK NXT High Capacity Steer Axle System for Fire and Rescue Vehicles**

**SUBJECT:** Service Instructions

**LIT NO:** 17730-311

**DATE:** April 2019

**REVISION:** B

### **TABLE OF CONTENTS**

<b>Section 1</b>	<b>Introduction</b> . . . . .	2	<b>Section 9</b>	<b>Component Replacement</b>	
<b>Section 2</b>	<b>Product Description</b> . . . . .	2	Fasteners . . . . .	31	
<b>Section 3</b>	<b>Important Safety Notice</b> . . . . .	4	Shock Absorbers . . . . .	31	
<b>Section 4</b>	<b>Parts List</b> . . . . .	8	Front Leaf Spring Frame Hanger . . . . .	32	
<b>Section 5</b>	<b>Special Tools</b> . . . . .	9	Leaf Spring and Clamp Group Assembly . . . . .	32	
<b>Section 6</b>	<b>Towing Procedures</b> . . . . .	10	Clamp Group Components . . . . .	35	
<b>Section 7</b>	<b>Preventive Maintenance</b>		STEERTEK NXT High Capacity Axle . . . . .	37	
	Component Inspection . . . . .	12	Steering Knuckle . . . . .	39	
	Lubrication Intervals . . . . .	13	Kingpin Bushing . . . . .	41	
	Kingpin Lubrication . . . . .	13	Tie Rod Ends and Cross Tube . . . . .	50	
	Tie Rod End Lubrication . . . . .	14	Air Disc Brakes • Drum Brakes Assembly . . . . .	51	
	Tie Rod Ends . . . . .	14	<b>Section 10</b>	<b>Torque Specifications</b> . . . . .	52
	Clamp Group Re-torque Interval . . . . .	17	<b>Section 11</b>	<b>Troubleshooting Guide</b> . . . . .	56
	Steering Knuckle . . . . .	17	<b>Section 12</b>	<b>Alignment Specifications</b> . . . . .	57
	Kingpin Bushing Wear . . . . .	18	<b>Section 13</b>	<b>Reference Material</b> . . . . .	58
	Shock Absorber . . . . .	19			
	Tire Inspection . . . . .	20			
	Wheel Bearing End Play Inspection . . . . .	22			
<b>Section 8</b>	<b>Alignment &amp; Adjustments</b>				
	Alignment Definitions . . . . .	23			
	Inspection Prior to Alignment . . . . .	25			
	Front Wheel Alignment . . . . .	26			
	Steering Stop . . . . .	28			
	Toe Setting . . . . .	29			

## SECTION 1 Introduction

This publication is intended to acquaint and assist maintenance personnel in the preventive maintenance, service, repair and rebuild of the Hendrickson STEERTEK NXT High Capacity Steer Axle System for applicable Fire and Rescue Vehicles.

**NOTE**

Use only Hendrickson Genuine parts for servicing this suspension system.

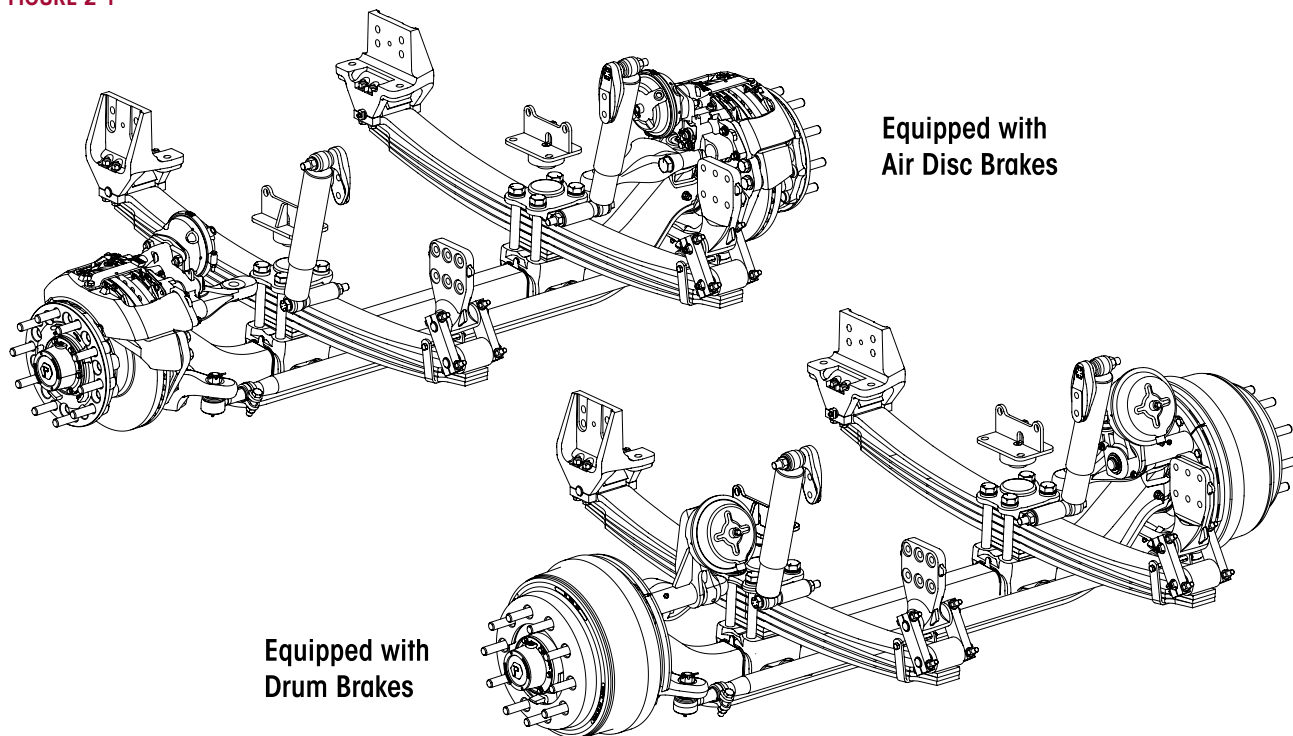
It is important to read and understand the entire Technical Procedure publication prior to performing any maintenance, service, repair, or rebuild of the product. The information in this publication contains parts lists, safety information, product specifications, features, proper maintenance, service, repair and rebuild instructions for STEERTEK NXT High Capacity Steer Axle System.

Hendrickson reserves the right to make changes and improvements to its products and publications at any time. Contact Hendrickson Tech Services for information on the latest version of this manual at 1-866-755-5968 (toll-free U.S. and Canada), 1-630-910-2800 (outside U.S. and Canada) or e-mail: techservices@hendrickson-intl.com.

The latest revision of this publication is available online at [www.hendrickson-intl.com](http://www.hendrickson-intl.com).

## SECTION 2 Product Description

**FIGURE 2-1**





**Hendrickson's STEERTEK NXT High Capacity Steer Axle System** — STEERTEK NXT High Capacity is the durable and lightweight alternative to forged I-beam axles. Optimized performance and integrated with Hendrickson spring and elastomer technology, STEERTEK NXT achieves complete suspension and axle system efficiency. The unique design provides up to 40 pounds of weight savings compared to traditional forged I-beam axles. Continuous beam architecture minimizes stress points for added durability. STEERTEK NXT High Capacity is rated for 100% off-highway use.

**Multiple Axle Configurations** — deep or standard drop, wide or narrow track, flexible spring seat centers and multiple steering arm and tie rod arm configurations.

**Brake Compatibility** — Compatible with drum 16.5" x 6" or air disc brakes with up to brakes and 315 to 445 mm tires.

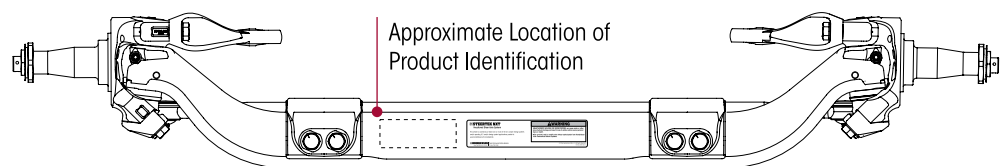
**Knuckle Assembly** — Removable kingpin design helps reduced maintenance. Premium kingpin bushings and seals provide enhanced protection from the elements to improve bushing life

**Leaf Spring Assembly** — The lightweight durable design provides excellent stability, ride and handling.

## TECHNICAL NOTES

1. STEERTEK NXT high-capacity system is approved for 100% OFF-highway usage. Other applications must be pre-approved by both Hendrickson and vehicle manufacturer. The system has a 18,000 to 24,000 pound capacity with load ratings up to 24,000 pound in certain applications. System capacity represents maximum loads on tires at ground level.
2. The STEERTEK NXT system is available with 70.89" Intersections (KPI).
3. The STEERTEK NXT system offers 3.74" axle beam drop height. Axle beam drop is measured from the kingpin intersection to the top of the axle.
4. This system is anti-lock braking system (ABS) ready. This system is compatible with industry standard wheel ends and brakes.
5. The STEERTEK NXT system product identification is etched on the front of the axle beam providing the following information, see Figure 2-2:
  - **Axle part number:** Identifies the features of the axle beam.
  - **Axle assembly number:** Identifies the complete assembly, which includes the steering knuckles and bracket assemblies.

**FIGURE 2-2**





## SECTION 3 Important Safety Notice

Proper maintenance, service and repair is important to the reliable operation of the suspension. The procedures recommended by Hendrickson and described in this technical publication are methods of performing such maintenance, service and repair.

The warnings and cautions should be read carefully to help prevent personal injury and to assure that proper methods are used. Improper maintenance, service or repair may damage the vehicle, cause personal injury, render the vehicle unsafe in operation, or void manufacturer's warranty.

Failure to follow the safety precautions in this manual can result in personal injury and / or property damage. Carefully read and understand all safety related information within this publication, on all decals and all such materials provided by the vehicle manufacturer before conducting any maintenance, service or repair.

### ■ EXPLANATION OF SIGNAL WORDS

Hazard "Signal Words" (Danger-Warning-Caution) appear in various locations throughout this publication. Information accented by one of these signal words must be observed to help minimize the risk of personal injury to service personnel, or possibility of improper service methods which may damage the vehicle or render it unsafe.



This is the safety alert symbol. It is used to alert you to potential personal injury hazards. Obey all safety messages that follow this symbol to avoid possible injury or death.

Additional 'Notes' or 'Service Hints' are utilized to emphasize areas of procedural importance and provide suggestions for ease of repair. The following definitions indicate the use of these signal words as they appear throughout the publication.



INDICATES AN IMMINENTLY HAZARDOUS SITUATION WHICH, IF NOT AVOIDED, WILL RESULT IN SERIOUS INJURY OR DEATH.



INDICATES A POTENTIAL HAZARDOUS SITUATION WHICH, IF NOT AVOIDED, CAN RESULT IN SERIOUS INJURY OR DEATH.



INDICATES A POTENTIAL HAZARDOUS SITUATION WHICH, IF NOT AVOIDED, MAY RESULT IN MINOR OR MODERATE INJURY, OR PROPERTY DAMAGE.

#### NOTE

An operating procedure, practice condition, etc., which is essential to emphasize.

#### SERVICE HINT

A helpful suggestion, which will make the servicing being performed a little easier and / or faster.

Also note that particular service operations may require the use of special tools designed for specific purposes. These special tools can be found in the Special Tools Section of this publication.



The torque symbol alerts you to tighten fasteners to a specified torque value. Refer to Torque Specifications Section of this publication.



## ■ SAFETY PRECAUTIONS

### WARNING

#### **FASTENERS**

DISCARD USED FASTENERS. ALWAYS USE NEW FASTENERS TO COMPLETE A REPAIR. FAILURE TO DO SO COULD RESULT IN FAILURE OF THE PART, OR MATING COMPONENTS, LOSS OF VEHICLE CONTROL, PERSONAL INJURY, OR PROPERTY DAMAGE.

LOOSE OR OVER TORQUED FASTENERS CAN CAUSE COMPONENT DAMAGE, LOSS OF VEHICLE CONTROL, PROPERTY DAMAGE, OR SEVERE PERSONAL INJURY. MAINTAIN CORRECT TORQUE VALUE AT ALL TIMES. CHECK TORQUE VALUES ON A REGULAR BASIS AS SPECIFIED, USING A TORQUE WRENCH THAT IS REGULARLY CALIBRATED. TORQUE VALUES SPECIFIED IN THIS TECHNICAL PUBLICATION ARE FOR HENDRICKSON SUPPLIED FASTENERS ONLY. IF NON-HENDRICKSON FASTENERS ARE USED, FOLLOW TORQUE SPECIFICATION LISTED IN THE VEHICLE MANUFACTURER'S SERVICE MANUAL.

### WARNING

#### **LOAD CAPACITY**

ADHERE TO THE PUBLISHED CAPACITY RATINGS FOR THE SUSPENSIONS. ADD-ON AXLE ATTACHMENTS (I.E. SLIDING FIFTH WHEELS) AND OTHER LOAD TRANSFERRING DEVICES CAN INCREASE THE SUSPENSION LOAD ABOVE THE RATED AND APPROVED CAPACITIES WHICH COULD RESULT IN FAILURE AND LOSS OF VEHICLE CONTROL, POSSIBLY CAUSING PERSONAL INJURY OR PROPERTY DAMAGE.

### WARNING

#### **REPAIR OR RECONDITIONING**

THE REPAIR OR RECONDITIONING OF SUSPENSION OR AXLE COMPONENTS IS NOT ALLOWED AS SHOWN ON LABEL IN FIGURE 3-1. ANY AXLE COMPONENTS FOUND TO BE DAMAGED OR OUT OF SPECIFICATIONS MUST BE REPLACED. ALL MAJOR HENDRICKSON COMPONENTS ARE HEAT TREATED AND TEMPERED. THE COMPONENTS CANNOT BE BENT, WELDED, HEATED, OR REPAIRED WITHOUT REDUCING THE STRENGTH OR LIFE OF THE COMPONENT. FAILURE TO FOLLOW THESE GUIDELINES CAN CAUSE LOSS OF VEHICLE CONTROL, POSSIBLE PERSONAL INJURY, DEATH, OR PROPERTY DAMAGE AND WILL VOID APPLICABLE WARRANTIES.

### WARNING

#### **SUPPORT THE VEHICLE PRIOR TO SERVICING**

PLACE THE VEHICLE ON A LEVEL FLOOR AND CHOCK THE WHEELS TO HELP PREVENT THE VEHICLE FROM MOVING. NEVER WORK UNDER A RAISED VEHICLE SUPPORTED ONLY BY A FLOOR JACK. ALWAYS SUPPORT A RAISED VEHICLE WITH SAFETY STANDS. BLOCK THE WHEELS AND MAKE SURE THE UNIT WILL NOT ROLL BEFORE RELEASING BRAKES. A JACK CAN SLIP OR FALL OVER. SERIOUS PERSONAL INJURY CAN RESULT.

### WARNING

#### **MODIFYING COMPONENTS**

DO NOT MODIFY OR REWORK PARTS WITHOUT AUTHORIZATION FROM HENDRICKSON. DO NOT SUBSTITUTE REPLACEMENT COMPONENTS NOT AUTHORIZED BY HENDRICKSON. USE OF MODIFIED, REWORKED, SUBSTITUTE OR REPLACEMENT PARTS NOT AUTHORIZED BY HENDRICKSON MAY NOT MEET HENDRICKSON'S SPECIFICATIONS, AND CAN RESULT IN FAILURE OF THE PART, LOSS OF VEHICLE CONTROL, POSSIBLE PERSONAL INJURY OR PROPERTY DAMAGE, AND WILL VOID ANY APPLICABLE WARRANTIES. USE ONLY HENDRICKSON AUTHORIZED REPLACEMENT PARTS.

### WARNING

#### **SHOCK ABSORBERS**

THE SHOCK ABSORBERS ARE A REQUIRED COMPONENT WHETHER SUPPLIED BY HENDRICKSON OR THE VEHICLE MANUFACTURER. HENDRICKSON IS NOT RESPONSIBLE FOR COMPONENTS SUPPLIED BY THE VEHICLE MANUFACTURER. FOR ASSISTANCE WITH INSPECTION, MAINTENANCE AND REBUILD INSTRUCTIONS, SEE VEHICLE MANUFACTURER.

### WARNING

#### **PERSONNEL PROTECTIVE EQUIPMENT**

ALWAYS WEAR PROPER EYE PROTECTION AND OTHER REQUIRED PERSONAL PROTECTIVE EQUIPMENT TO HELP PREVENT PERSONAL INJURY WHEN PERFORMING VEHICLE MAINTENANCE, REPAIR OR SERVICE.



## WARNING

### AXLE CAMBER

UNAUTHORIZED WELDING OR MODIFICATIONS CAN CAUSE CRACKS OR OTHER AXLE STRUCTURAL DAMAGE AND RESULT IN LOSS OF VEHICLE CONTROL, SEVERE PERSONAL INJURY OR DEATH. DO NOT BEND, WELD OR MODIFY AXLE WITHOUT AUTHORIZATION FROM HENDRICKSON TRUCK COMMERCIAL VEHICLE SYSTEMS.

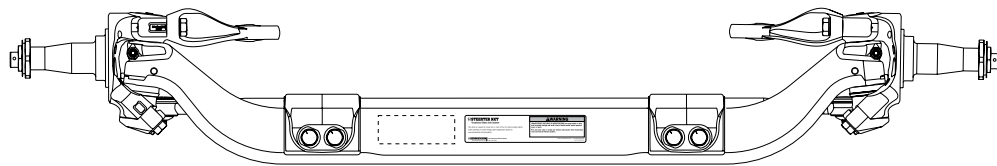
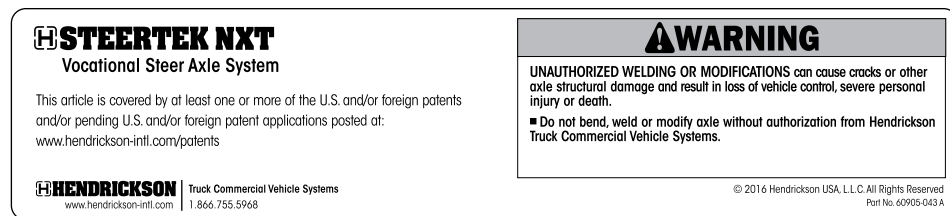
**AXLE CAMBER IS NOT ADJUSTABLE.** DO NOT CHANGE THE AXLE CAMBER ANGLE OR BEND THE AXLE BEAM, SEE FIGURE 3-1. BENDING THE AXLE BEAM TO CHANGE THE CAMBER ANGLE CAN DAMAGE THE AXLE AND REDUCE AXLE STRENGTH, WILL VOID HENDRICKSON'S WARRANTY AND CAN CAUSE LOSS OF VEHICLE CONTROL, POSSIBLY CAUSING PERSONAL INJURY OR PROPERTY DAMAGE.

## WARNING

### IMPROPER JACKING METHOD

IMPROPER JACKING METHOD CAN CAUSE STRUCTURAL DAMAGE AND RESULT IN LOSS OF VEHICLE CONTROL, SEVERE PERSONAL INJURY OR DEATH. DO NOT USE AXLE BEAM OUTBOARD OF AXLE SEATS. REFER TO VEHICLE MANUFACTURER FOR PROPER JACKING INSTRUCTIONS, SEE FIGURE 3-1.

**FIGURE 3-1**



## WARNING

### DAMAGED AXLE COMPONENTS

IF A VEHICLE EQUIPPED WITH A STEERTEK NXT SYSTEM IS INVOLVED IN A CRASH, THE AXLE STEER KNUCKLES MUST BE DISASSEMBLED AND A THOROUGH INSPECTION OF THE AXLE MUST BE PERFORMED NOTING THE CONDITION OF THE AXLE BEAM, KINGPINS, AND KNUCKLE ASSEMBLIES, INCLUDING THE AREAS OF AXLE TO KINGPIN INTERFACE, FOR ANY DAMAGE, GAPS, KINGPIN MOVEMENT OR PLAY. IF ANY COMPONENT APPEARS DAMAGED, OR THE KINGPINS APPEAR TO CONTAIN ANY DAMAGE, GAPS, MOVEMENT OR PLAY, THE COMPLETE AXLE ASSEMBLY MUST BE REPLACED.

IN ADDITION, IN THE EVENT A CRASH RESULTS IN EXCESSIVE SIDE LOAD DAMAGE TO ADJACENT PARTS, SUCH AS A BENT WHEEL, HUB, OR SPINDLE, IT IS STRONGLY RECOMMENDED TO REPLACE SUCH ADJACENT PARTS AND THE COMPLETE AXLE ASSEMBLY.

CONTACT HENDRICKSON TECH SERVICES WITH ANY QUESTIONS. FAILURE TO REPLACE ANY DAMAGED COMPONENTS CAN CAUSE LOSS OF VEHICLE CONTROL, POSSIBLE PERSONAL INJURY, DEATH, OR PROPERTY DAMAGE AND WILL VOID ANY APPLICABLE WARRANTIES.

## CAUTION

### PROCEDURES AND TOOLS

A MECHANIC USING A SERVICE PROCEDURE OR TOOL WHICH HAS NOT BEEN RECOMMENDED BY HENDRICKSON MUST FIRST SATISFY HIMSELF THAT NEITHER HIS SAFETY NOR THE VEHICLE'S SAFETY WILL BE JEOPARDIZED BY THE METHOD OR TOOL SELECTED. INDIVIDUALS DEVIATING IN ANY MANNER FROM THE INSTRUCTIONS PROVIDED ASSUME ALL RISKS OF POTENTIAL PERSONAL INJURY OR DAMAGE TO EQUIPMENT INVOLVED.



## WARNING

### OFF-ROADWAY TOWING

WHEN A VEHICLE IS DISABLED AND EQUIPPED WITH A STEERTEK NXT SYSTEM, CARE MUST BE TAKEN TO ENSURE THERE IS NO DAMAGE TO THE SUSPENSION OR AXLE WHEN TOWING THE VEHICLE. THE USE OF TOW STRAPS ARE NECESSARY TO TOW A DISABLED VEHICLE FROM A REPAIR FACILITY PARKING LOT INTO THE SHOP BAY. THE TOW STRAPS SHOULD BE CONNECTED TO THE TOW HOOKS PROVIDED BY THE VEHICLE MANUFACTURER AT THE FRONT OF THE BUMPER. IF THE USE OF TOW HOOKS IS NOT AN OPTION, THEN TOW STRAPS MAY BE WRAPPED AROUND THE FRONT STEERTEK NXT SYSTEM, (SEE FIGURE 3-2) IN A MANNER THAT IS ACCEPTABLE FOR TOWING THE VEHICLE FROM A REPAIR FACILITY PARKING LOT INTO THE SHOP BAY. DO NOT USE A TOW CHAIN AROUND THE FRONT STEERTEK NXT SYSTEM TO TOW THE VEHICLE, DOING SO WILL DAMAGE THE AXLE AND VOID ANY APPLICABLE WARRANTY, (SEE FIGURE 3-2). FOR DETAILED INSTRUCTIONS FOR ON-HIGHWAY TOWING, SEE TOWING PROCEDURE SECTION OF THIS PUBLICATION.

FIGURE 3-2



## WARNING

### TORCH / WELDING

DO NOT USE A CUTTING TORCH TO REMOVE ANY FASTENERS. THE USE OF HEAT ON SUSPENSION COMPONENTS WILL ADVERSELY AFFECT THE STRENGTH OF THESE PARTS. A COMPONENT DAMAGED IN THIS MANNER CAN RESULT IN THE LOSS OF VEHICLE CONTROL AND POSSIBLE PERSONAL INJURY OR PROPERTY DAMAGE.

EXERCISE EXTREME CARE WHEN HANDLING OR PERFORMING MAINTENANCE IN THE AREA OF THE LEAF SPRING ASSEMBLY AND AXLE. DO NOT CONNECT ARC WELDING GROUND LINE TO THE LEAF SPRING ASSEMBLY OR AXLE. DO NOT STRIKE AN ARC WITH THE ELECTRODE ON THE LEAF SPRING ASSEMBLY OR AXLE. DO NOT USE HEAT NEAR THE LEAF SPRING ASSEMBLY OR AXLE. DO NOT NICK OR GOUGE THE LEAF SPRING ASSEMBLY OR AXLE. SUCH IMPROPER ACTIONS CAN DAMAGE THE LEAF SPRING ASSEMBLY OR THE AXLE, AND CAN CAUSE LOSS OF VEHICLE CONTROL AND POSSIBLE PERSONAL INJURY OR PROPERTY DAMAGE.

## WARNING

### PARTS CLEANING

SOLVENT CLEANERS CAN BE FLAMMABLE, POISONOUS AND CAUSE BURNS. TO HELP AVOID SERIOUS PERSONAL INJURY, CAREFULLY FOLLOW THE MANUFACTURER'S PRODUCT INSTRUCTIONS AND GUIDELINES AND THE FOLLOWING PROCEDURE:

1. WEAR PROPER EYE PROTECTION
2. WEAR CLOTHING THAT PROTECTS YOUR SKIN
3. WORK IN A WELL VENTILATED AREA
4. DO NOT USE GASOLINE, OR SOLVENTS THAT CONTAIN GASOLINE. GASOLINE CAN EXPLODE
5. HOT SOLUTION TANKS OR ALKALINE SOLUTIONS MUST BE USED CORRECTLY. FOLLOW THE MANUFACTURER'S RECOMMENDED INSTRUCTIONS AND GUIDELINES CAREFULLY TO HELP PREVENT PERSONAL ACCIDENT OR INJURY

DO NOT USE HOT SOLUTION TANKS OR WATER AND ALKALINE SOLUTIONS TO CLEAN GROUND OR POLISHED PARTS. DOING SO WILL CAUSE DAMAGE TO THE PARTS AND VOID ANY APPLICABLE WARRANTY.

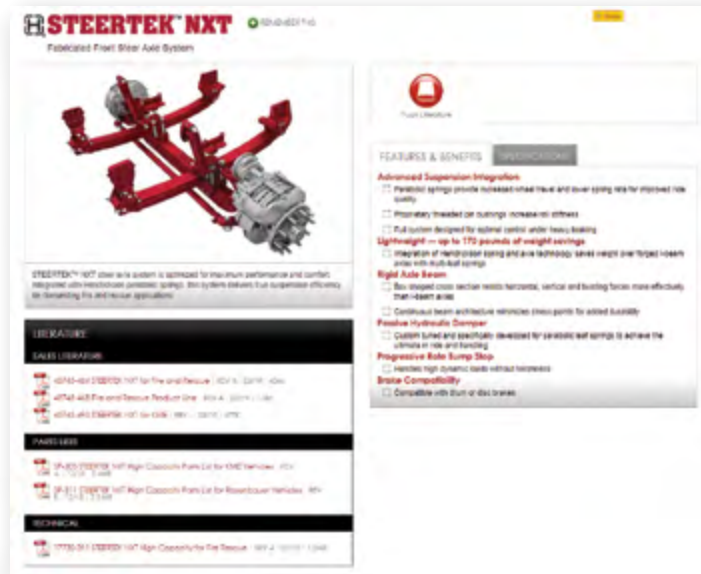


# SECTION 4 Parts List

Refer to the specific parts list for your vehicle available online at [www.hendrickson-intl.com/Truck/Fire-Rescue/STEERTEK-NXT-Fire](http://www.hendrickson-intl.com/Truck/Fire-Rescue/STEERTEK-NXT-Fire)

**NOTE** Additional brake component part and service information is referenced in the Parts List.

**FIGURE 4-1**





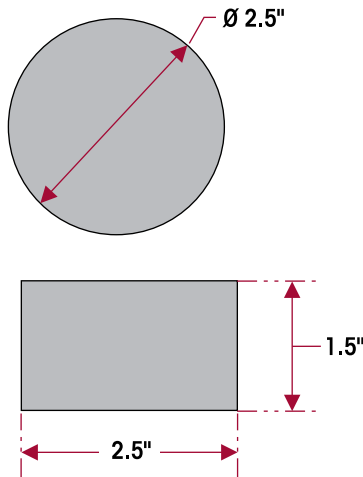


# SECTION 5 Special Tools

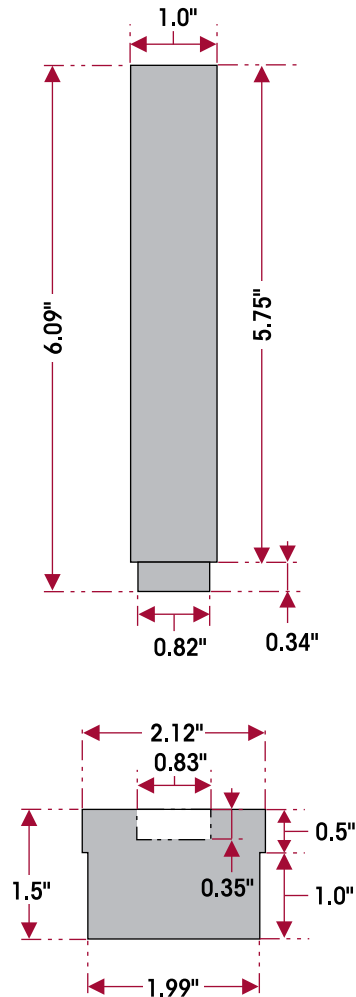
## SHOP MADE TOOLS

These shop made tools are designed to install and remove kingpin bushings. Bushing tools are made from cold rolled steel or equivalent. Drawings are for reference only. Hendrickson does not supply these.

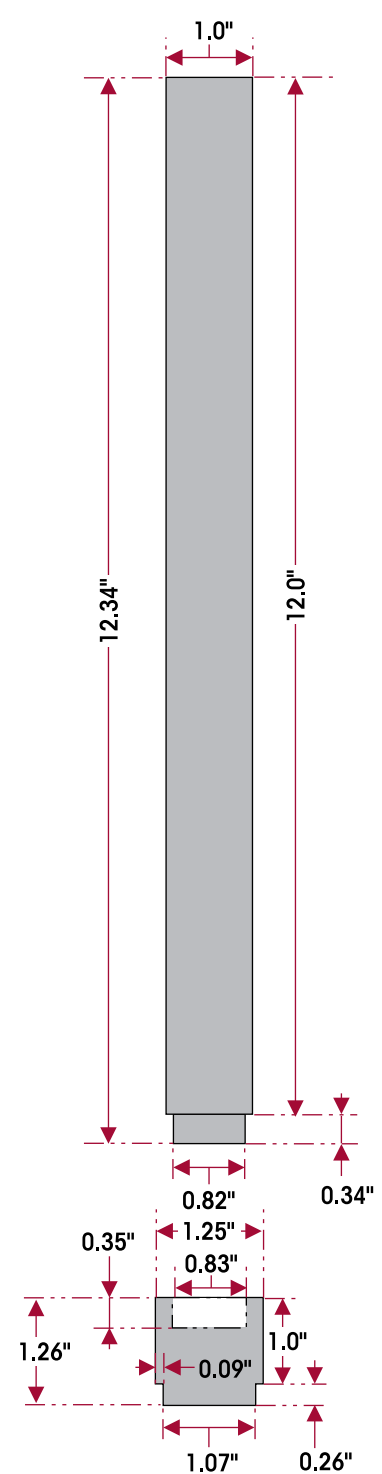
### KINGPIN BUSHING / SEAL DRIVER



### KINGPIN BUSHING AND SEAL INSTALLER / REMOVER



### AXLE COLLAR DRIVER



### KINGPIN BUSHING TOOL – ADJUSTABLE STRAIGHT FLUTE REAMER

The dimension of cutting diameter must facilitate a range of **2.00"-2.01"**



## SECTION 6

# Towing Procedures

### ON-HIGHWAY AND ON-ROADWAY

Hendrickson recommends that a vehicle equipped with a STEERTEK NXT steer axle and suspension system be towed by the following methods (listed in order of preference) for ON-HIGHWAY or ON-ROADWAY applications.

- **METHOD 1** — Wheel lift, the ideal towing procedure
- **METHOD 2** — Towing the vehicle from the rear
- **METHOD 3** — Conventional axle fork

Please read, understand and comply with any additional towing instructions and safety precautions that may be provided by the vehicle manufacturer.

Hendrickson will not be responsible for any damage to the axle, suspension or other vehicle components resulting from any towing method or fixture not authorized by Hendrickson.

Please contact Hendrickson Tech Services at 1-866-755-5968 or send e-mail to: [techservices@hendrickson-intl.com](mailto:techservices@hendrickson-intl.com) with any questions regarding proper towing procedures for vehicles equipped with a STEERTEK NXT system.

#### METHOD 1 — WHEEL LIFT

This method provides the greatest ease for towing the vehicle. Lifting at the tires helps reduce the risk of possible damage to the axle, suspension, and engine components during towing operations, see Figure 6-1.

**FIGURE 6-1**



#### METHOD 2 — TOWING VEHICLE FROM THE REAR

This method is preferred when the proper equipment is not available to perform the wheel lift method and is necessary for wreckers not equipped with an under lift system.



## METHOD 3 — AXLE FORK LIFT

This is an alternative method for towing the vehicle, but requires standard tow forks and designated lift points.

### NOTE

When lifting a vehicle with an under lift boom, care must be taken not to damage the engine's oil pan. Vehicles equipped with a front fairing may require removal of the front fairing prior to towing to prevent component damage.

- Ensure there is sufficient clearance between the oil pan and the boom.
  - Release the tractor brakes.
  - Install safety straps prior to towing the vehicle, it is preferred to use nylon safety straps. Chains have a tendency to bind and may cause damage to the axle.
1. Use a tow fork with a minimum of 4.5" opening, 2" shank, see Figure 6-2.
  2. Install the fork in the boom properly.
  3. The proper tow fork location is centered between the locknuts on the axle seats, see Figure 6-3.

FIGURES 6-2



FIGURE 6-3



## OFF-ROADWAY TOWING



### WARNING

WHEN A VEHICLE IS DISABLED AND EQUIPPED WITH A STEERTEK NXT SYSTEM, CARE MUST BE TAKEN TO ENSURE THERE IS NO DAMAGE TO THE SUSPENSION OR AXLE WHEN TOWING THE VEHICLE. THE USE OF TOW STRAPS ARE NECESSARY TO TOW A DISABLED VEHICLE FROM A REPAIR FACILITY PARKING LOT INTO THE SHOP BAY. THE TOW STRAPS SHOULD BE CONNECTED TO THE TOW HOOKS PROVIDED BY THE VEHICLE MANUFACTURER AT THE FRONT OF THE BUMPER. IF THE USE OF TOW HOOKS IS NOT AN OPTION, THEN TOW STRAPS MAY BE WRAPPED AROUND THE FRONT STEERTEK NXT SYSTEM, (SEE FIGURE 6-4) IN A MANNER THAT IS ACCEPTABLE FOR TOWING THE VEHICLE FROM A REPAIR FACILITY PARKING LOT INTO THE SHOP BAY. DO NOT USE A TOW CHAIN AROUND THE FRONT STEERTEK NXT SYSTEM TO TOW THE VEHICLE, DOING SO WILL DAMAGE THE AXLE AND VOID ANY APPLICABLE WARRANTY, (SEE FIGURE 6-4).

- NYLON STRAPS OR CHAINS ARE NOT RECOMMENDED FOR ON-HIGHWAY OR ON-ROADWAY TOWING.

FIGURE 6-4





## SECTION 7

# Preventive Maintenance

The STEERTEK NXT High Capacity steer axle system is low maintenance system. Following appropriate inspection procedure is important to help ensure the proper maintenance and operation of the STEERTEK NXT High Capacity steer axle system and component parts function to their highest efficiency. Look and replace any bent, cracked, worn or damaged parts.

### HENDRICKSON RECOMMENDED PREVENTIVE MAINTENANCE INTERVALS

- **The first 1,000 miles**
- **Vocational** – every 25,000 miles (40,000 kilometers) or 6 months, whichever comes first

### COMPONENT INSPECTION

- **Axle seat** — Check torque. Inspect axle seats for cracks or damage. Inspect axle seat liners, check for any missing liner material. If liner material is missing disassemble clamp group and replace liners, see Component Replacement Section of this publication.
- **Clamp group** — Check torque on clamp group mounting hardware. Refer to the Clamp Group Re-Torque Interval in this section.
- **Fasteners** — Look for any loose or damaged fasteners on the entire suspension. Make sure all fasteners are tightened to the specified torque. Refer to Torque Specifications Section of this publication if fasteners are supplied by Hendrickson, non-Hendrickson fasteners, refer to the vehicle manufacturer. Use a calibrated torque wrench to check torque in a tightening direction. As soon as the fastener starts to move, record the torque. Correct the torque if necessary. Replace any worn or damaged fasteners.
- **Front and rear spring hangers** — Check for cracks or loose mounting hardware. Replace if necessary, see Component Replacement Section of this publication for replacement procedure.
- **Shackle bracket** — Look for any signs of excessive wear to shackle and shackle bracket.
- **Shock absorber** — Look for any signs of dents or leakage. Refer to the Shock Absorber Inspection in this section.
- **Steel leaf spring** — Look for cracks. Replace if cracked or broken. Check the front bushings for any wear or deterioration. Replace leaf spring assembly if any of the previous conditions are observed. See the Component Replacement Section of this publication for replacement procedure.
- **Operation** — All steering components must move freely through the full range of motion from axle stop to axle stop.
- **Steering pivot points** — Check for looseness at all pivot points. Inspect and lubricate all pivot points. Refer to the STEERTEK NXT High Capacity Greasing and Lubrication Specifications Table 7-1, in this section.
- **STEERTEK NXT High Capacity axle and Tie Rods** — Inspect for any cracks or dents on the axle, and also refer to the Tie Rod Ends Inspection and Lubrication Section in this publication. Replace as necessary.
- **Tire wear** — Inspect tires for wear patterns that may indicate suspension damage or misalignment. See Tire Inspection in this section.
- **Wear and damage** — Inspect all parts of suspension for wear and damage. Look for bent or cracked parts. Replace all worn or damaged parts.

See vehicle manufacturer's applicable publications for other preventive maintenance requirements.



## LUBRICATION INTERVALS

For vehicles equipped with the STEERTEK NXT High Capacity steer axle system, regular lubrication intervals should be followed to help prevent premature wear to the kingpin bushings and tie rod ends, see Lubrication Specification Table 7-1 below.

**NOTE** The recommended service lubrication interval is a guideline, the vehicle may require increased lubrication interval depending on severity of operation.

TABLE 7-1

STEERTEK NXT High Capacity — Greasing and Lubrication Specifications				
Component	Greasing Interval	Grease	NLGI Grade	Outside Temperature
Kingpin Bushings	Maximum of 10,000 miles (16,100 kilometers) or 90 days, whichever comes first.	Multipurpose Grease	2	Refer to the lubricant manufacturer's specifications for the temperature service limits applicable to your area.
Tie Rod Ends				
Drag Link	See Vehicle Manufacturer			
Threaded Pin	Every 3 months	Lithium Base Grease	2	

**NOTE:** Lubrication greases acceptable for use on the STEERTEK NXT will carry a designation of NLGI #2 EP and rated GC-LB or equivalent.

## KINGPIN LUBRICATION

1. Place vehicle on the ground.
2. Prior to greasing the kingpins on the vehicle, the suspension must be in a loaded condition.
3. Clean off all the grease zerks and grease gun tip with a clean shop towel prior to lubrication.
4. Lubricate the kingpins through the grease zerks on the top and bottom of the steering knuckle, see Lubrication Specification Table 7-1 above.
5. Force the required lubricant into the upper and lower kingpin grease zerks, (Figure 7-1) until new lubricant flows out from the upper kingpin connection and steering knuckle and the thrust bearing purge location, see Figures 7-1 and 7-2.

**NOTE** Greasing at the lower zerk should purge grease from the thrust bearing shell. The left and right side of the STEERTEK NXT High Capacity steer axle system have steel roller thrust bearings.

FIGURE 7-1

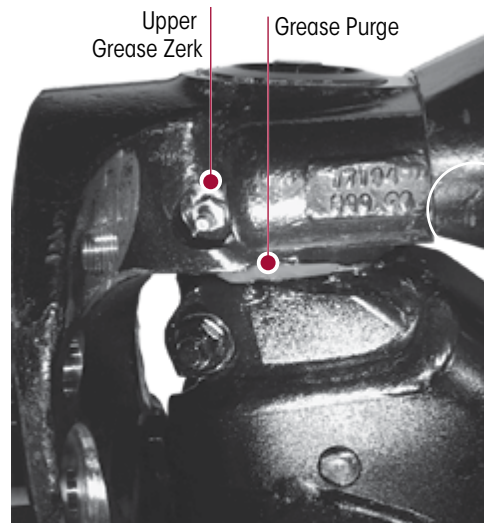
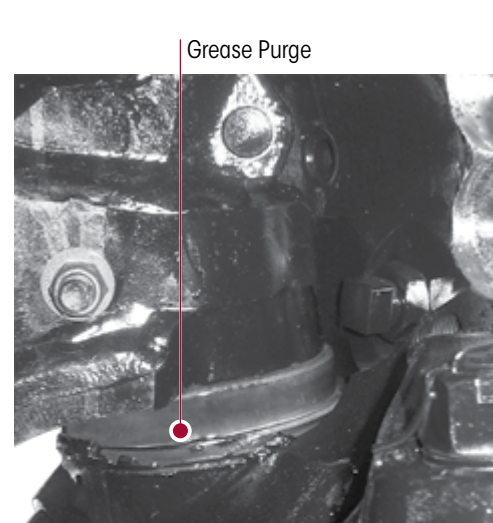


FIGURE 7-2





## TIE ROD END LUBRICATION

### LUBRICATION PROCEDURE

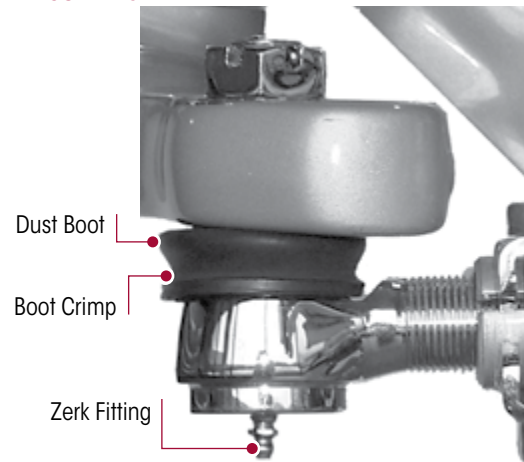
1. Turn the vehicle wheels straight ahead.
2. Wipe the grease zerk and grease gun tip with clean shop towels.
3. Wipe the seal / boot clean with shop towels.
4. Attach a grease gun to the grease zerk. Either a hand or pneumatic grease gun is acceptable. If air operated grease gun is used, system air pressure should not exceed 150 psi (1035 kPa).

**CAUTION**

EXCEEDING THE MAXIMUM AIR PRESSURE TO THE GREASE ZERK CAN CAUSE DAMAGE TO THE DUST BOOT AND COMPONENT FAILURE.

5. Dirt, water, and discolored old grease should flow from the relief vents or purge holes near the boot crimp or bellows area, see Figure 7-3. Continue to purge grease until fresh grease flows from the purge area.
6. If the tie rod end is designed for lube service and it will not accept grease proceed as follows:
  - a. Remove the grease zerk
  - b. Inspect the threaded grease zerk hole in the tie rod end and remove any obstructions
  - c. Install a new grease zerk
  - d. Continue the lubrication procedure
  - e. If the tie rod end will not accept grease following this procedure it will be necessary to replace the tie rod end, (see Tie Rod End replacement in the Component Replacement Section of this publication)
7. Apply grease until all the old grease is purged from the boot and fresh grease is coming out.

FIGURE 7-3



## TIE ROD ENDS

### INSPECTION

Before beginning this inspection procedure, the entire system must be unloaded (i.e., the front end of the vehicle must be raised and supported with safety stands).

**CAUTION**

DO NOT GREASE THE TIE ROD ASSEMBLY BEFORE PERFORMING THE INSPECTION. DOING SO CAN INHIBIT EFFORTS TO DETERMINE ACTUAL WEAR.

**CAUTION**

REPLACE THE ENTIRE TIE ROD END IF THE BOOT IS TORN OR MISSING, FAILURE TO DO SO CAN CAUSE PREMATURE WEAR OF THE TIE ROD END.

1. Block rear wheels of vehicle. Using the bottom of the axle beam or the frame rails, raise the front end off the ground and support with stands.
2. With the engine off, turn the wheels from full left to full right and then return to the straight-ahead position.
3. Check that the boots are in place and completely installed over the tie rod ends.
4. Check for cracking or tears in the boots. Also check the boot seals for damage. Replace the entire tie rod end if the boot is damaged.



## WARNING

THE COTTER PIN MUST BE INSTALLED CORRECTLY THROUGH THE TIE ROD END WITH THE CASTLE NUT TIGHTENED TO THE PROPER TORQUE SPECIFICATION IN ORDER TO SECURELY ATTACH THE TIE ROD. LOSS OF THE COTTER PIN CAN CAUSE THE TIE ROD END NUT TO BECOME LOOSE AND ADVERSELY AFFECT VEHICLE STEERING AND POSSIBLY RESULT IN TOTAL LOSS OF STEERING CONTROL.

5. Check that the tie rod end nut is installed and secured with a cotter pin. If the cotter pin is missing, check the nut torque specification and then install a new cotter pin. Always tighten the castle nut to specified torque when setting the cotter pin. **DO NOT** back off the nut to insert cotter pin.

## WARNING

IT IS CRITICAL TO CHECK THE  $\frac{5}{8}$ " TIE ROD CLAMP BOLT HEAD LOCATION TO VERIFY THE CLAMP FASTENERS HAVE SUFFICIENT CLEARANCE AWAY FROM THE LOWER SHOCK ABSORBER MOUNT AT FULL WHEEL CUT. THE FASTENERS MUST NOT CONTACT THE LOWER SHOCK ABSORBER MOUNT. FAILURE TO DO SO CAN CAUSE ONE OR MORE COMPONENTS TO FAIL CAUSING LOSS OF VEHICLE CONTROL AND POSSIBLE PERSONAL INJURY OR PROPERTY DAMAGE.

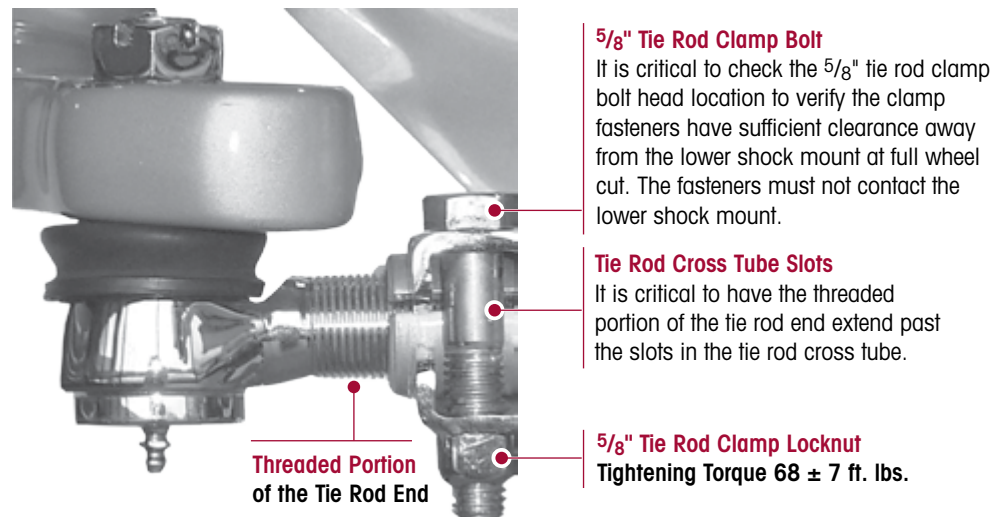
6. Verify the  $\frac{5}{8}$ " tie rod clamp bolt head does not contact the lower shock absorber mount at full wheel cut, see Figure 7-4.

## WARNING

THE THREADED PORTION OF THE TIE ROD END MUST EXTEND PAST THE SLOTS INTO THE TIE ROD CROSS TUBE, SEE FIGURE 7-4. FAILURE TO DO SO CAN CAUSE COMPONENT DAMAGE, LOSS OF VEHICLE CONTROL AND POSSIBLE PERSONAL INJURY OR PROPERTY DAMAGE.

7. Check that the tie rod end is threaded correctly into the cross tube and is engaged deeper than the end of the cross tube slot. The tie rod end must be visible the entire length of the cross tube slot, see Figure 7-4.

FIGURE 7-4



8. Check that grease zerks are installed. Replace a damaged grease zerk with a new one.

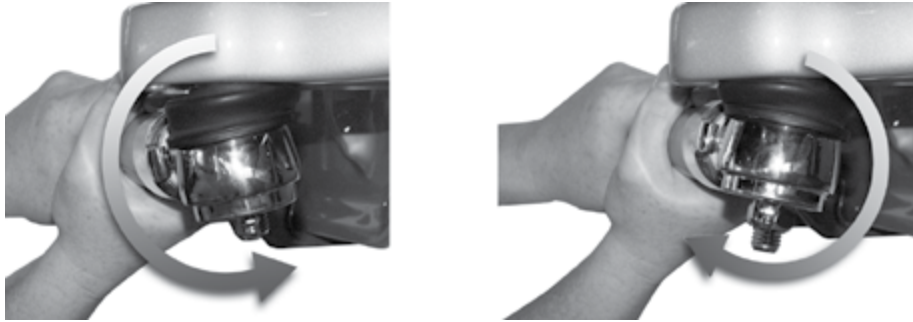
## CAUTION

DO NOT USE THE FOLLOWING ITEMS OR METHODS TO CHECK FOR MOVEMENT OF THE TIE ROD ASSEMBLY, WHICH CAN CAUSE DAMAGE TO COMPONENTS:

- A CROW BAR, PICKLE FORK OR 2 X 4.
  - ANYTHING OTHER THAN HANDS USED TO GRASP AND ROTATE THE CROSS TUBE ASSEMBLY (CAN RESULT IN DAMAGE TO THE CROSS TUBE).
  - EXCESSIVE PRESSURE OR FORCE APPLIED TO THE TIE ROD ENDS OR THE JOINTS OF THE ASSEMBLY.
9. By hand or using a pipe wrench, with jaw protectors to avoid gouging the cross tube, rotate the cross tube toward the front of the vehicle and then toward the rear. After rotating, center the cross tube. If the cross tube will not rotate in either direction, replace both tie rod ends, see Figure 7-5.



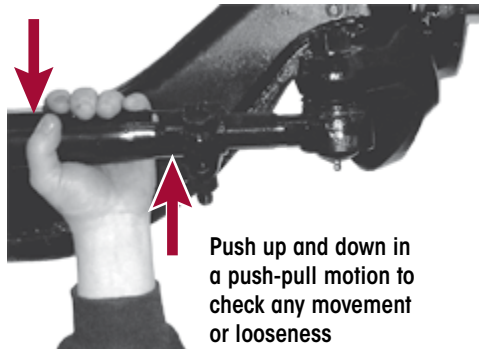
FIGURE 7-5



10. Position yourself directly below the tie rod end. Using both hands, grab the assembly end as close to the tie rod end as possible (no more than 6" or 152.4 mm). Apply hand pressure with reasonable human effort vertically up and down in a push-pull motion several times (using approximately 50-100 pounds of force). Check for any movement or looseness at both tie rod end locations, see Figure 7-6.

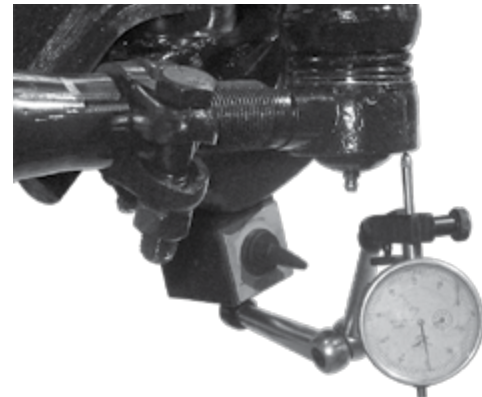
11. If there is any movement in the tie rod assembly, install a magnetic based dial indicator on the tie rod arm, see Figure 7-7.

FIGURE 7-6



Push up and down in a push-pull motion to check any movement or looseness

FIGURE 7-7



12. Set the dial indicator to zero.

13. Apply hand pressure with reasonable human effort vertically up and down in a push-pull motion several times (using approximately 50-100 pounds of force). Observe the reading on the dial indicator.

14. If the reading is more than 0.060", replace both tie rod ends at the next service interval.

15. If a tie rod end exhibits  $\geq 0.125$ " of movement by hand, the vehicle should be removed immediately from use and the tie rod end be replaced.

**NOTE**

According to the Commercial Vehicle Safety Alliance (CVSA), the "out of service" criteria for front steer axle tie rod assemblies on any commercial vehicle is: Any motion other than rotational between any linkage member and its attachment point of more than 1/8" (3 mm) measured with hand pressure only. (393.209(d)), (published in the North American Standard Out-of-Service Criteria Handbook, April 1, 2006.)





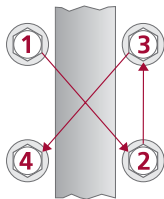
## CLAMP GROUP RE-TORQUE INTERVAL

1. Clamp group hex bolts and axle collar hex cap bolts must be torqued to specification at preparation for delivery.
2. Clamp group hex bolts and axle collar hex cap bolts must be re-torqued at 1,000 miles.
3. Thereafter follow the 6 month / 50,000 mile visual inspection and annual re-torque interval.

### WARNING

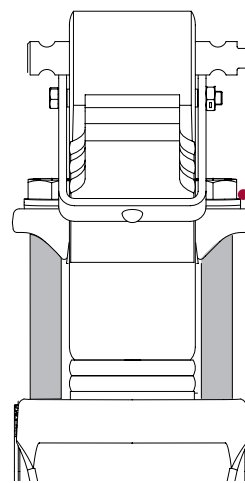
ENSURE CLAMP GROUP IS ALIGNED PROPERLY PRIOR TO TIGHTENING HARDWARE. FAILURE TO DO SO CAN CAUSE LOSS OF VEHICLE CONTROL, PROPERTY DAMAGE OR PERSONAL INJURY.

FIGURE 7-9



4. Ensure that the clamp group is properly aligned and the hex bolts are seated in the axle seat, and the top pad is centered on the leaf spring, see Figure 7-8.
5. Check for the signs of component or bolt movement.
6. If signs of movement are present, disassemble the clamp group fasteners, check for component wear or damage and replace as necessary, then install new clamp group fasteners and repeat Steps 4 through 5.
7. Tighten the clamp group hex bolts evenly in 100 foot pounds increments to 600 ± 20 foot pounds torque in the proper pattern to achieve uniform bolt tension, see Figure 7-9.

FIGURE 7-8



**IMPORTANT NOTE**  
Ensure that Clamp Group Assembly is properly aligned

1" Clamp Group Hex Bolt  
Tightening Torque at the Bolt Head  
600 ± 20 ft. lbs.

## STEERING KNUCKLE

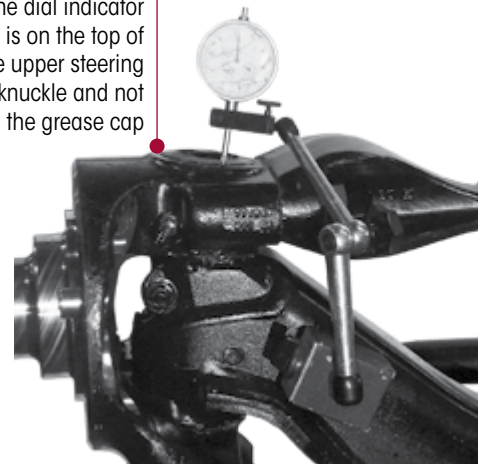
### CHECKING VERTICAL END PLAY (UP AND DOWN MOVEMENT)

The operating specification for vertical end play on the steering knuckle is 0.008" to 0.030".


1. Chock the rear tires to help prevent the vehicle from moving.
2. Set the parking brakes.
3. Use a jack to raise the vehicle until both tires are 1" off the ground.
4. Place a dial indicator on each side of the axle as follows:
  - a. Index the wheels slightly (left or right).
  - b. Place the magnetic dial indicator base on the axle, see Figure 7-10.
  - c. Place the tip of the dial indicator on the top of the upper steering knuckle (not on the grease cap).
5. Set the dial indicator to "0" (zero).
6. Lower the jack.

FIGURE 7-10

Ensure the tip of the dial indicator is on the top of the upper steering knuckle and not on the grease cap





7. If vertical end play is greater than 0.030", or below 0.008" an adjustment of the upper knuckle is necessary. If the vertical end play is:
  - **Greater than 0.030"**, add shims until the proper vertical end play is achieved.
  - **Less than 0.008"**, remove shims until the proper vertical end play is achieved.
8. Retighten the kingpin draw keys to  188 ± 12 foot pounds torque.

## KINGPIN BUSHING WEAR

### CHECKING STEERING KNUCKLE LATERAL MOVEMENT

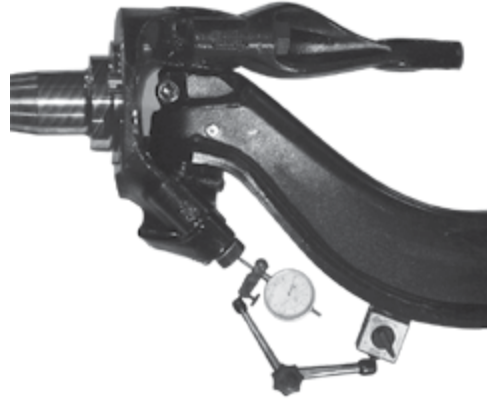
**NOTE**

If one (1) bushing is worn or damaged, it is mandatory to replace both the upper and lower bushings on that knuckle assembly.

**FIGURE 7-11**  
CHECKING UPPER KINGPIN BUSHING



**FIGURE 7-12**  
CHECKING LOWER KINGPIN BUSHING



1. Chock the wheels to help prevent the vehicle from moving. Set the parking brake.
2. Use a jack to raise the vehicle until the wheels are off the ground. Support the vehicle with safety stands.
3. **CHECKING THE UPPER KINGPIN BUSHING.** Install the base of a dial indicator onto the axle beam and place the tip against the steering knuckle, see Figure 7-11.
4. Set the dial indicator to "0" zero.
5. Move the top of the tire in and out by applying reasonable constant pressure and then release, see Figure 7-13.
6. Check the reading on the dial indicator. If the dial indicator moves more than 0.015", the upper bushing is worn or damaged. Replace both bushings. Refer to the Kingpin Bushing replacement procedure in the Component Replacement Section of this publication.
7. **CHECKING THE LOWER KINGPIN BUSHING.** Install a dial indicator so that the base is on the axle and the indicator tip is against the inside of the bottom of the knuckle, see Figure 7-12.
8. Set the dial indicator to "0" zero.
9. Move the bottom of the tire in and out. If the dial indicator moves more than 0.015", the lower bushing is worn or damaged. Replace both kingpin bushings. Refer to the Component Replacement Section of this publication.

**FIGURE 7-13**





## SHOCK ABSORBER

### NOTE

It is not necessary to replace shock absorbers in pairs if only one (1) shock absorber requires replacement.

Hendrickson offers a long service life, premium shock absorber for use on STEERTEK NXT High Capacity suspensions. If shock absorber replacement is necessary, Hendrickson recommends that original Hendrickson shock absorbers be replaced with identical Hendrickson Genuine parts for servicing. Failure to do so will affect the suspension performance, durability, and will void the warranty.

Inspection of the shock absorber can be performed by doing a heat test, and a visual inspection. For instructions on shock absorber replacement see the Component Replacement Section of this publication.

FIGURE 7-14



### HEAT TEST

1. Drive the vehicle at moderate speeds on rough road for minimum of fifteen minutes.



**DO NOT GRAB THE SHOCK ABSORBER AS IT COULD POSSIBLY BE HOT AND CAUSE PERSONAL INJURY.**

2. Use an infrared thermometer to check the temperature of the shock absorber. This can also be performed by carefully touching the shock absorber body below the dust cover. Touch the frame to get an ambient reference, see Figure 7-14. A warm shock absorber is acceptable, a cold shock absorber should be replaced.
3. To inspect for an internal failure, remove and shake the suspected shock absorber. Listen for the sound of metal parts rattling inside. Rattling of metal parts can indicate that the shock absorber has an internal failure.

### VISUAL INSPECTION

Look for any of the potential problems shown in Figure 7-15 when doing a visual inspection. Inspect the shock absorbers fully extended. Replace as necessary.

FIGURE 7-15

### SHOCK ABSORBER VISUAL INSPECTION - UNACCEPTABLE CONDITIONS



Damaged upper or lower mount



Damaged upper or lower bushing



Damaged dust cover and / or shock body



Bent or dented shock absorber



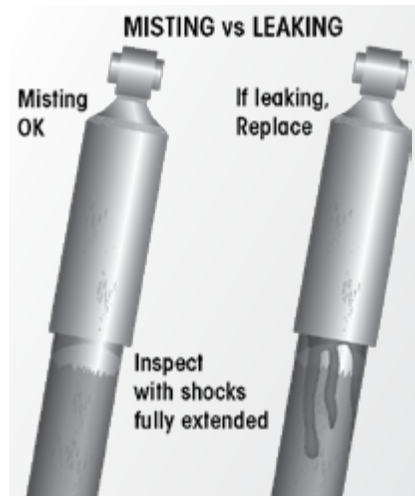
Improper installation  
Example: washer (if equipped installed backwards)

**LEAKING VS. MISTING VISUAL INSPECTION**

The inspection must not be conducted after driving in wet weather or a vehicle wash. The shock absorber needs to be free from water. Many shock absorbers are often misdiagnosed as failures. Misting is the process whereby very small amounts of shock absorber fluid evaporate at a high operating temperature through the upper seal of the shock absorber. When the “mist” reaches the cooler outside air, it condenses and forms a film on the outside of the shock absorber body. Misting is perfectly normal and necessary function of the shock absorber. The fluid which evaporates through the seal area helps to lubricate and prolong the life of the seal.

**FIGURE 7-16**

A shock absorber that is truly leaking and needs to be replaced will show signs of fluid leaking in streams from the upper seal. These streams can easily be seen when the shock absorber is fully extended, underneath the main body (dust cover) of the shock absorber. Look for these potential problems when doing a visual inspection. Inspect the shock absorbers fully extended. Replace as necessary.



**NOTE**

The STEERTEK NXT High Capacity steer axle system is equipped with a premium seal on the shock absorber, however this seal will allow for misting to appear on the shock absorber body (misting is not a leak and is considered acceptable).

Inspect the shock absorber fully extended. **A shock absorber that is truly leaking** will show signs of fluid **leaking in streams from the upper seal**. These streams can easily be seen, underneath the main body (dust cover) of the shock absorber. Replace as necessary.

**TIRE INSPECTION**

The leading causes of tire wear are the following, in order of importance:

1. Tire Pressure
2. Toe Setting
3. Thrust Angle
4. Camber

The following tire Inspection guidelines are based upon Technology & Maintenance Council (TMC) recommended practices. Any issues regarding irregular tire wear where Hendrickson is asked for assistance will require tire and alignment maintenance records, reference TMC’s literature numbers RP 219A, RP 230, or RP 642.

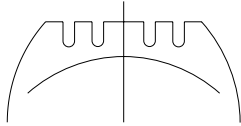
Tire wear is normally the best indicator of vehicle alignment condition. If tires are wearing too rapidly or irregularly, alignment corrections may be needed. The tire wear patterns described below can help isolate specific alignment problems.

The most common conditions of concern are:

- Overall Fast Wear (Miles per 32nd)
- Feather Wear
- Rapid Shoulder Wear (One Shoulder Only)
- One-Sided Wear
- Diagonal Wear
- Cupping

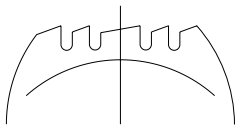


**FIGURE 7-17**  
**OVERALL FAST WEAR**  
(Miles per 32nd)



**Overall Fast Wear** — Fast wear can be described as exhibiting a good, but accelerated wear pattern. It is typically caused by operating conditions, such as mountainous terrain, frequency and severity of turning, abrasive road surfaces in combination with vehicle configurations and their attributes—such as power steering, heavy axle loads, high wheel cuts, setback axles, short wheel base tractors, long wheel base straight trucks. To correct this problem, consult with vehicle and tire manufacturers when specifying equipment or replacing tires. For more information, see TMC RP 219A publication, page 11. For information on how to accurately measure and record tire rates, see TMC RP 230 publication.

**FIGURE 7-18**  
**FEATHER WEAR**



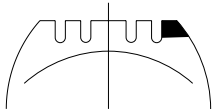
**Feather wear** — Tread ribs or blocks worn so that one side is higher than the other resulting in step-offs across the tread face. Generally, ribs or blocks exhibit this wear. To spot this problem, do the following:

With one hand flat on the tread of the tire and a firm down pressure, slide your hand across the tread of the tire. In one direction, the tire will feel smooth and in the opposite direction there will be a sharp edge to the tread. Typical causes of feather wear include: excessive side force scrubbing, resulting from conditions of misalignment such as excessive toe, drive axle misalignment, worn, missing or damaged suspension components, bent tie rods or other chassis misalignment.

To correct this problem, tires can be rotated to another axle for maximum utilization of remaining tread. Additionally, diagnose the vehicle itself and correct misalignment condition as required. If steer tire feathers are in opposite directions, an improper toe condition is most likely the cause. For more information, see TMC RP 219A publication, page 5.

If feather wear on both steer tires is in the same direction, drive axle or other chassis misalignment is indicated. If one steer tire shows feather wear and the other steer tire has normal wear, a combination of toe and drive axle or chassis misalignment is indicated.

**FIGURE 7-19**  
**RAPID SHOULDER WEAR**  
(One Shoulder Only)



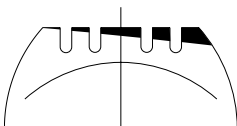
**Rapid Shoulder Wear (One Shoulder Only)** — Is defined as a tire worn on the edge of one shoulder, sometimes extending to inner ribs. It can progress to diagonal wipeout. For more information, see TMC RP 219A publication, page 22.

This wear condition is usually caused by excessive toe or excessive camber. These conditions can be created by a misaligned or bent axle and can also be caused by loose or worn wheel bearings.

To correct this type of rapid shoulder wear:

- *Tires* – Change direction of rotation of tire. If shoulder wear is severe, remove and retread.
- *Vehicle* – Diagnose misalignment and / or mechanical condition and correct.

**FIGURE 7-20**  
**ONE-SIDED WEAR**



**One-sided wear** — Is excessive wear on one side of tire extending from the shoulder towards the center of the tread. For more information, see TMC RP 219A, page 26.

One-sided wear is usually caused by improper alignment, worn kingpins, loose wheel bearings, excessive camber, excessive axle loads, non-parallel axles, or non-uniform tire and wheel assembly caused by improper bead seating or bent wheel.

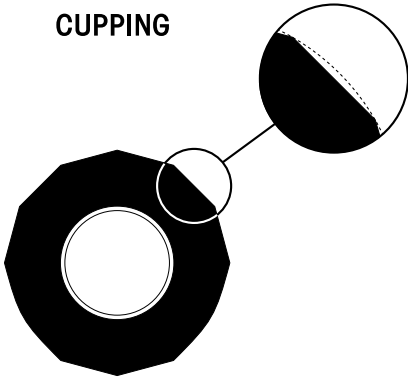
To correct one-sided wear:

- *Tires* – Depending on severity, rotate tires to another axle position or, if worn to minimum tread depths, submit for possible retreading.
- *Vehicle* – Diagnose mechanical problem and correct.

**Diagonal Wear** — Can be described as localized flat spots worn diagonally across the tread at approximately 25-35° angles, often repeating around the tread circumference. For more information, see TMC RP 219A publication, page 20.

Diagonal wear is usually caused by bad wheel bearings, toe out, mis-mounting of tire and wheel assembly to axle, and mismatched duals for size and / or inflation pressures. It may start as brake skid. Diagonal wear is aggravated by high speed empty or light load hauls.

FIGURE 7-22

**CUPPING**

**Cupping** — Localized, dished out areas of fast wear creating a scalloped appearance around the tire. Cupping, which appears around the tire on the shoulder ribs, may also progress to adjoining ribs, see TMC RP 219A publication, page 7.

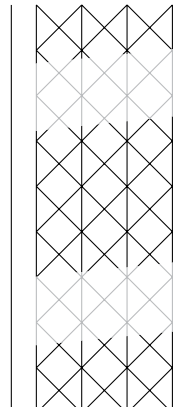
Cupping is usually a result of moderate-to-severe imbalance, improper rim / wheel mounting, excessive wheel end play or other assembly non-uniformity. It can also be due to lack of shock absorber control on some suspension types.

To solve cupping problems:

- *Tires* – Correct mismatch or balance problem. If ride complaints arise, steer tires may be rotated to drive or trailer axle.
- *Vehicle* – Diagnose component imbalance condition, i.e., wheel, rim, hub, brake, drum. Correct as necessary.

To correct diagonal wear, reverse direction of rotation of the tire. If wear is excessive, true tire. If the source of trouble is the vehicle, diagnose cause and correct as needed.

FIGURE 7-21

**DIAGONAL WEAR****WHEEL BEARING END PLAY INSPECTION**

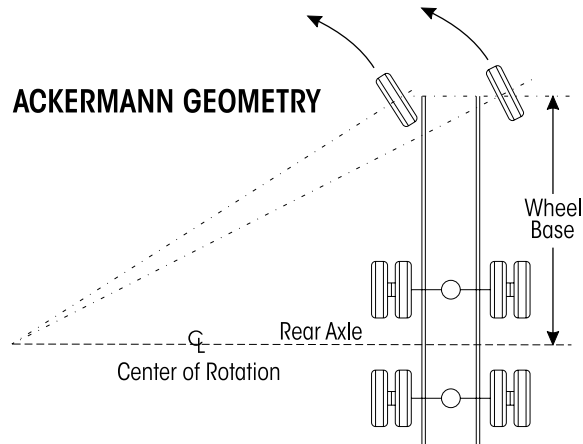
Refer to Meritor for wheel bearing end play inspection and wheel bearing adjustment procedures.

## SECTION 8

# Alignment & Adjustments

### ALIGNMENT DEFINITIONS

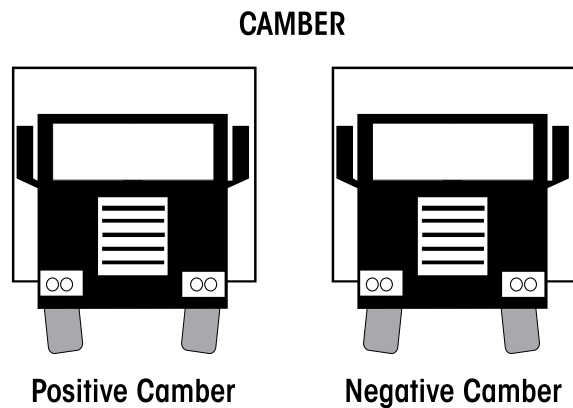
FIGURE 8-1



**Ackermann steering geometry** — The geometry of the four bar linkage consisting of the front axle, two knuckle assemblies, and tie rod assembly is designed to provide free rolling of front tire in a turn. Ackermann geometry is dependent upon the steering axle track-width and wheelbase of the vehicle. Improper geometry results in wheel scrub in turns which generally appears as toe wear on the tire, usually more wear on one side of the vehicle than the other due to the operational route of the vehicle.

**Bump steer (feedback)** — The feedback felt through the steering linkage to the steering wheel when a steer axle tire hits a bump in the road. This occurs because the axle-end of the drag link and the axle attachment point of the spring do not travel in parallel circular arcs as the suspension moves up and down. This condition can also be caused by trapped air in the power steering system.

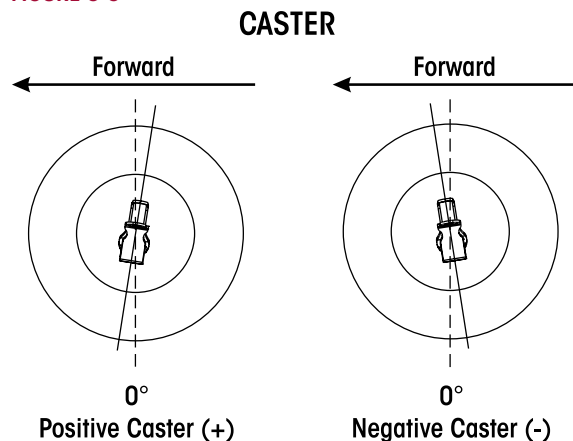
FIGURE 8-2



**Camber** — The angle formed by the inward or outward tilt of the wheel reference to a vertical line. Camber is positive when the wheel is tilted outward at the top and is negative when the wheel is tilted inward at the top.

Excessive positive camber may cause smooth wear on the outer half of the tire tread. Excessive negative camber may cause wear on the inner half of the tread. Static-unloaded camber angles are built into the axle to put the loaded tire perpendicular to the road.

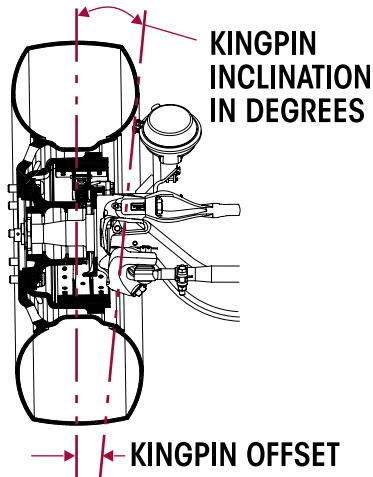
FIGURE 8-3



**Caster** — The forward or rearward tilt of the steering axle kingpin in reference to a vertical line. The angle is measured in degrees. Caster is positive when the top of the steering axis is tilted rearward and is negative when the tilt is forward. Proper caster is important for directional stability and returnability. Too much positive caster can cause shimmy, excessive steering effort and is normally a vehicle performance and handling consideration. Uneven positive caster may create a steering pull toward the side with the lower caster. This attribute may be used to compensate for crowned roads.



FIGURE 8-4

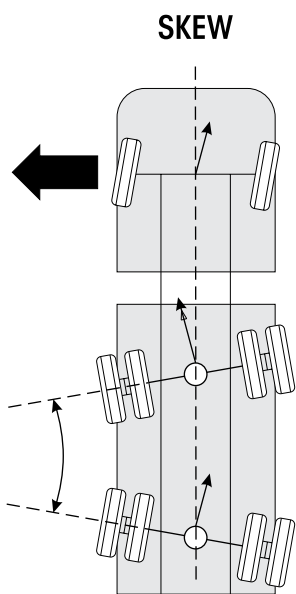


**Kingpin inclination (KPI)** — The inward tilt of the kingpin from the vertical. This front suspension parameter has a pronounced effect on steering effort and returnability. As the front wheels are turned around an inclined kingpin, the front of the truck is lifted. This lifting of the vehicle is experienced as steering effort when the turn is executed and exhibits itself as recovery force when the steering wheel is released.

**Kingpin offset** — The distance between the center of the tire patch and intersection of the kingpin axis with the ground. This parameter of front-end geometry is important in vehicles without power steering and has a major effect on static steering. If there is no kingpin offset, the tires must scrub around the center of the pin patch when turned in a static condition, resulting in higher static steering efforts.

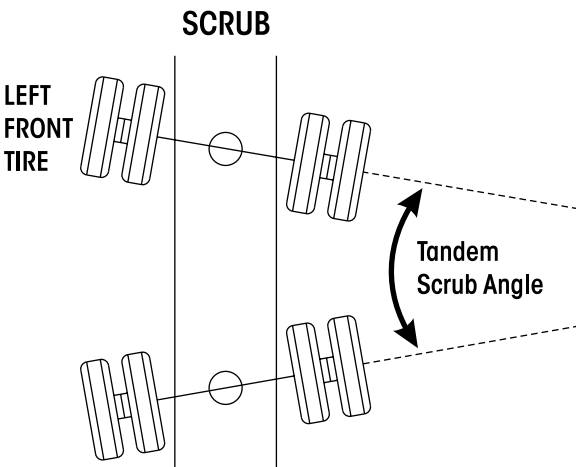
**Steering arm** — The component that connects the drag link to the axle knuckle assembly.

FIGURE 8-5



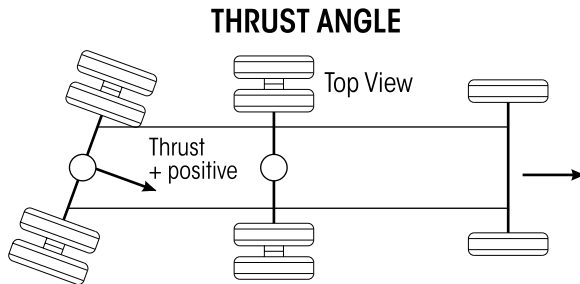
**Scrub, skew, tram angle or parallelism** — The angle formed by two thrust or tracking lines of a tandem (or multiple) axle vehicle. As indicated by the term “parallelism”, the ideal condition is when the two thrust lines form a 0° angle, or are parallel to each other. Positive skew or tram is when the distance between the right axle ends is less than the distance between the left.

FIGURE 8-6



Any scrub angle other than 0° will cause the tandem axles to work against each other. The steer axle must be turned to offset the “push” of the tandem axles to keep the vehicle moving straight ahead. This causes every tire on the vehicle to “scrub”. Tire wear from tandem scrubbing occurs at the leading edge of the steer tires in a pattern called “inside / outside” wear, that is, the inside edge of the left steer tire and the outside edge of the right steer tire will exhibit irregular wear for example. Additional tire wear may occur on all tandem axle tires.

FIGURE 8-7



**Thrust angle, tracking, or square** — The angle formed by the center-line of the vehicle frame (geometric center-line) and the direction that an axle points. As indicated by the term “square”, the ideal value for the angle is 0° or when the axle center-line is at 90° or perpendicular to the geometric center-line. Thrust or tracking to the right is positive, and to the left is negative.

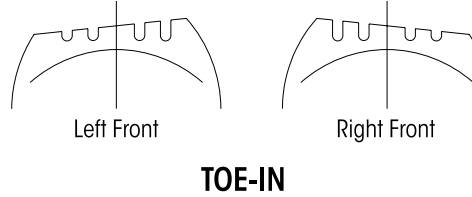
A steering correction is required to offset the effect of the thrust angles and keeps the vehicle traveling in a straight line. It results in a lateral offset between the steer and drive axle tires commonly referred to as “dog tracking.”

**Tie rod arm (Ackermann-arm, cross tube arm)** — The component that transmits steering forces between left and right axle knuckle assemblies through the cross tube assembly.



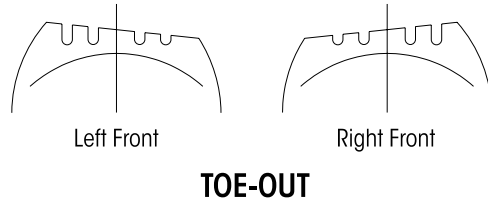


**FIGURE 8-8**



**Toe-in** — Is when the horizontal line intersects in front of the wheels, or the wheels are closer together in front than in the back. Toe-in is commonly designated as positive, toe-out as negative. Excessive toe-in wears the outside edge of the tires. Steer axle toe is adjustable to reduce wear to the leading edge of the tire and also to avoid road wander. Toe is adjusted in a static, unloaded condition so that the tires will run in a straight line under a dynamic, loaded condition.

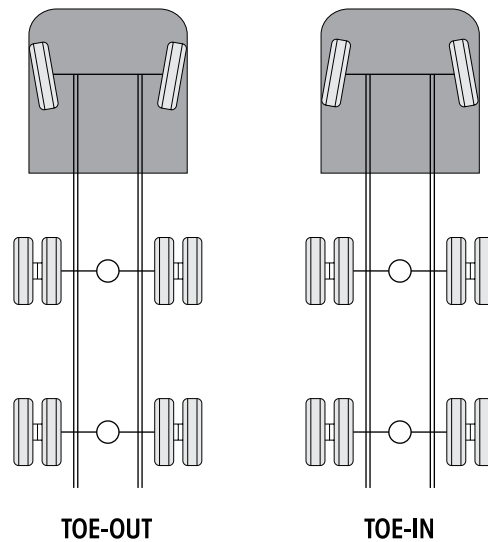
**FIGURE 8-9**



**Toe-out** — Is when the horizontal lines intersect behind the wheels, or the wheels are closer together in back than in front. Toe-in is commonly designated as positive, toe-out as negative. Excessive toe-out wears the inside edge of the tires. Steer axle toe is adjustable to reduce wear to the leading edge of the tire and also to avoid road wander. Toe is adjusted in a static, unloaded condition so that the tires will run in a straight line under a dynamic, loaded condition.

**FIGURE 8-10**

### TOTAL TOE



**Toe-out on turns** — (See Ackermann Geometry). Excessive turning angles such as those encountered in pickup and delivery operations may contribute to premature tire wear. Be advised that the greater turning angles, the more that toe and camber change. If you have any doubt regarding the optimum turning angles for your operation, contact the vehicle's manufacturer, axle OEM, tire OEM and alignment equipment manufacturer for advice.

**Total toe** — The angle formed by two horizontal lines through the planes of two wheels. Steer axle toe is adjustable to reduce wear to the leading edge of the tire and also to avoid road wander. Toe is adjusted in a static, unloaded condition so that the tires will run in a straight line under a dynamic, loaded condition.

## INSPECTION PRIOR TO ALIGNMENT

### WHEELS AND TIRES

Examine the following items:

- Tires are inflated to the manufacturer's specified tire pressure.
- Steer axle tires are the same size and type.
- Lug nuts are tightened to manufacturer's specified torque.
- Wheels are balanced.
- Wheels and tires are free of excessive wear and damage.
- Wheel bearing end play is within OEM specification.

### FRONT SUSPENSION

Inspect the following:

- All fasteners are installed and tightened to the specified torque. See Torque Specification Section of this publication.
- Leaf springs are free of wear or damage.



- Shock absorbers are free of wear and damage.
- Vehicle ride height for both the front and rear are within specification. Follow manufacturer's guidelines (if equipped).
- Front and rear spring mounts are free of wear or damage.

### INSPECT TIE ROD ENDS

Perform Tie Rod Inspection procedure; refer to the Preventive Maintenance Section of this publication.

### REAR AXLE AND REAR SUSPENSION

The rear axle can cause front tire wear. If the outer edge of one front tire is worn and the inner edge of the other front tire is worn, check the following:

- Make sure the rear axle (especially a tandem axle) is correctly aligned. Refer to the procedure dictated by the vehicle or suspension manufacturer.
- All fasteners including U-bolts (if applicable) are installed and tightened to the specified torque.
- The leaf springs are not worn or damaged.
- The bushings in the leaf springs are not worn or damaged.
- The torque rods (if used) are correctly adjusted (if adjustable).
- The frame is not bent or twisted.
- Refer to any additional recommendations and specifications from the manufacturer of vehicle on rear axles and suspensions. Reference The Technology & Maintenance Council (TMC) Guidelines for Total Vehicle Alignment.

### FRONT WHEEL ALIGNMENT

Hendrickson recommends technicians review The Technology & Maintenance Council's publication (TMC) "Guidelines for Total Vehicle Alignment" (TMC RP 642).

Check total (front and rear) vehicle wheel alignment when any of the following occurs:

- Every 80,000 to 100,000 miles, or 12-18 months (normal maintenance).
- When the vehicle does not steer correctly.
- To correct a tire wear condition.

For rear wheel alignment specifications and adjustments refer to the vehicle manufacturer.

The front wheel alignment specifications can be found in the Alignment Specifications Section of this publication. There are two types of front wheel alignment:

1. **Minor alignment** – a minor front wheel alignment is done **for all** normal maintenance conditions, see below.
2. **Major alignment** – a major alignment is done when uneven or excessive tire wear is evident, or response at the steering wheel is sluggish, or the need for major wheel alignment check and adjustment is required, see below.

### MINOR FRONT WHEEL ALIGNMENT

Perform the minor front wheel alignment in the following sequence:

1. Inspect all systems that affect wheel alignment. Refer to the Inspection Prior to Alignment in this section.
2. Check the wheel bearing end play.
3. Check and adjust toe.
4. Check and adjust the vehicle ride height as specified in the Preventive Maintenance Section of this publication.



## MAJOR FRONT WHEEL ALIGNMENT

Be certain to follow wheel alignment inspection intervals as specified by the original equipment manufacturer. Before performing a major front wheel alignment, it is recommended that alignment equipment calibration be checked to ensure proper vehicle alignment.

Major wheel alignment is accomplished in the following sequence of operation:

1. Inspect all the systems that influence the wheel alignment. Refer to the Inspection Prior to Alignment in this section.
2. Check and adjust the maximum turn angle, refer to the Steering Stop Adjustment Procedure in this section, see Figures 8-11 and 8-12.

FIGURE 8-11



FIGURE 8-12



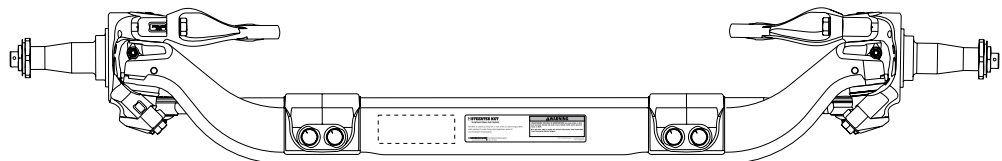
3. If the vehicle is equipped with power steering, check the pressure relief in the power steering system and reset if necessary. Refer to the vehicle manufacturer regarding the subject: Adjusting the Pressure Relief in the Power Steering System.
4. Check the turning angle. Refer to the original equipment manufacturer specifications.
5. Check the kingpin (or steering axis) inclination. Refer to Kingpin Inclination under Alignment Definitions in this section.

### WARNING

AXLE CAMBER IS NOT ADJUSTABLE. DO NOT CHANGE THE AXLE CAMBER ANGLE OR BEND THE AXLE BEAM. BENDING THE AXLE BEAM TO CHANGE THE CAMBER ANGLE CAN DAMAGE THE AXLE AND REDUCE AXLE STRENGTH, AND WILL VOID HENDRICKSON'S WARRANTY. A BENT AXLE BEAM CAN CAUSE LOSS OF VEHICLE CONTROL, POSSIBLY CAUSING PERSONAL INJURY OR PROPERTY DAMAGE, SEE FIGURE 8-13.

FIGURE 8-13

<p><b>STEERTEK NXT</b> Vocational Steer Axle System</p> <p>This article is covered by at least one or more of the U.S. and/or foreign patents and/or pending U.S. and/or foreign patent applications posted at: <a href="http://www.hendrickson-intl.com/patents">www.hendrickson-intl.com/patents</a></p> <p><b>HENDRICKSON</b>   Truck Commercial Vehicle Systems <a href="http://www.hendrickson-intl.com">www.hendrickson-intl.com</a>   1.866.755.5968</p>	<p><b>WARNING</b></p> <p>UNAUTHORIZED WELDING OR MODIFICATIONS can cause cracks or other axle structural damage and result in loss of vehicle control, severe personal injury or death.</p> <p>■ Do not bend, weld or modify axle without authorization from Hendrickson Truck Commercial Vehicle Systems.</p> <p><small>© 2016 Hendrickson USA, L.L.C. All Rights Reserved Part No. 60905-043 A</small></p>
---	--



6. Check camber angle. **DO NOT** attempt to adjust camber. Refer to "Camber" under the Alignment Definitions in this section.
7. It is necessary to verify that all ride heights (front and rear) are within specifications prior to checking caster to get an accurate caster reading.
8. Check and adjust caster angle. Refer to Caster Angle under Alignment Definitions in this section.

**NOTE**

The use of two (2) different angle caster shims will not change cross caster. Cross caster is the difference between the caster readings for left and right side of the vehicle.

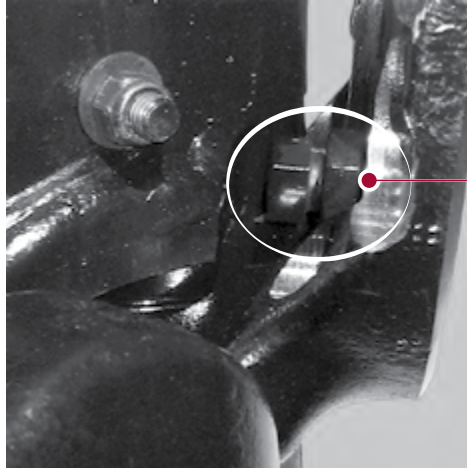
9. Check and adjust toe-in, refer to "Toe Setting" in this section.

**STEERING STOP****ADJUSTMENT PROCEDURE**

When the axle or steering knuckle is replaced, the steering stop adjustment must be checked.

The steering stop adjustment procedure is as follows:

1. Drive truck onto turntables and chock the rear wheels.
2. Measure the wheel cut. The wheel cut is determined by steering the tires. Wheel cut is measured at the inside wheel only, therefore the tires must be turned to the full lock position for each right hand and left hand direction. Refer to the vehicle manufacturer for exact specifications.
3. Increase the wheel cut by loosening the jam nuts and screw the axle stops in clockwise.
4. Tighten the jam nuts.

**FIGURE 8-14**

Ensure the sides of square head axle stops are set parallel to the axle beam

**NOTE**

It is very important that the sides of the square head axle stops are set parallel to the axle beam to ensure a good contact point on the axle, see Figure 8-14.

5. Decrease the wheel cut by loosening the jam nuts and screw the axle stops out counter-clockwise.
6. Tighten the jam nuts to  $50 \pm 10$  foot pounds torque.
7. Measure the wheel cut and check for any interference with related steering components.

**WARNING**

ALWAYS CHECK / RESET THE STEERING GEAR BOX POPPETS WHEN THE WHEEL CUT IS DECREASED. FOLLOW MANUFACTURER'S GUIDELINES FOR THE GEAR BOX POPPET RESETTING PROCEDURE. FAILURE TO DO SO CAN RESULT IN PREMATURE FAILURE OF THE AXLE OR STEERING KNUCKLE. THIS CONDITION CAN CAUSE LOSS OF VEHICLE CONTROL, PERSONAL INJURY OR PROPERTY DAMAGE AND VOID ANY APPLICABLE WARRANTY.



## TOE SETTING

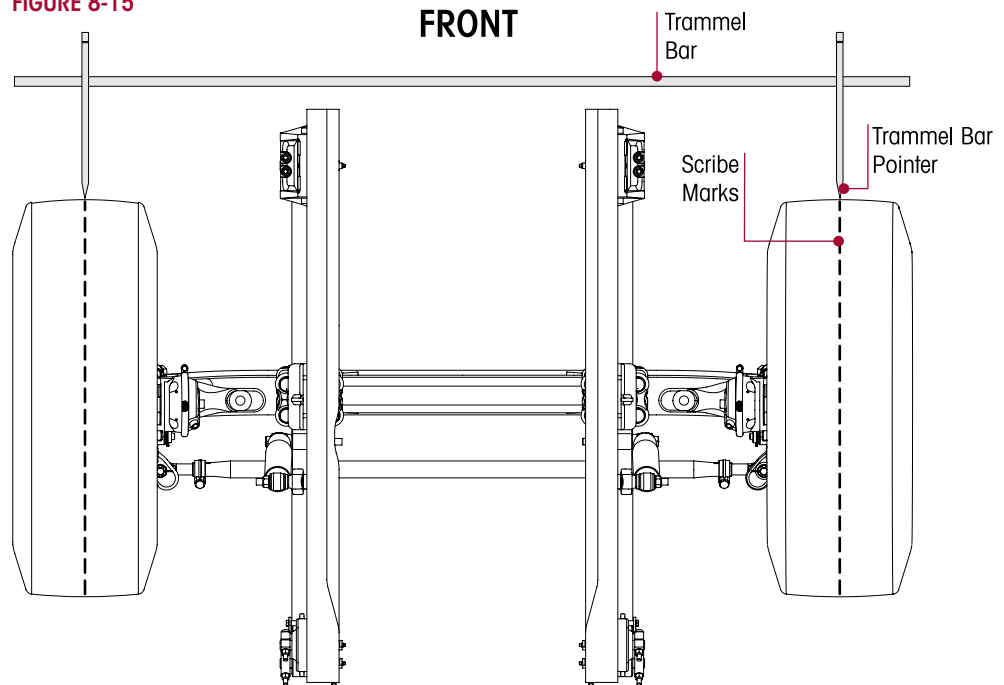
1. Place the vehicle on a level floor with the wheels in a straight ahead position.
2. Raise the vehicle and support the front axle with jack stands.
3. Use paint and mark the center area of tread on both steer axle tires around the complete outer diameter of the tires.
4. Scribe a line through both steer axle tires in the painted area around the complete outer diameter of the tires.
5. Raise the vehicle and remove the jack stands.
6. Set the vehicle on the ground.

### NOTE

**DO NOT** measure toe-in with the front axle off the ground. The weight of the vehicle must be on the front axle when toe-in is measured.

7. Use a trammel bar and measure the distance between the scribe marks at the rear of the steer axle tires. Record the measurement.
8. Install the trammel bar and measure the distance between the scribe marks at the front of the steer axle tires. Record the measurement, see Figure 8-15.

**FIGURE 8-15**



### NOTE

When setting up the trammel bar the pointers should be level with the spindles at the front and rear of the steer axle tires.

9. To calculate the toe setting subtract the front measurement from the rear measurement, the difference between the two will equal the toe-in / toe-out measurement.

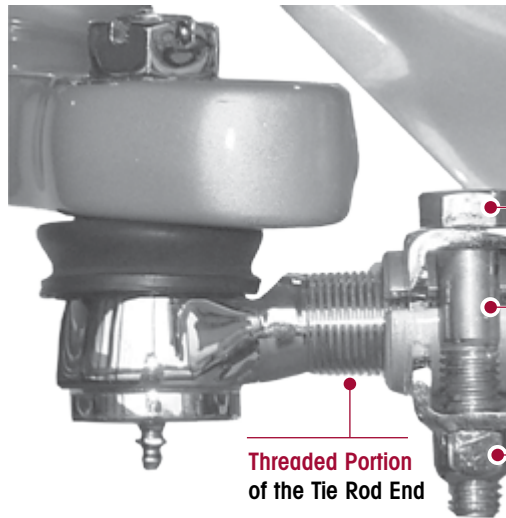
### WARNING

THE THREADED PORTION OF THE TIE ROD END MUST EXTEND PAST THE SLOTS INTO THE TIE ROD CROSS TUBE. SEE FIGURE 8-16. FAILURE TO DO SO CAN CAUSE COMPONENT TO FAIL CAUSING LOSS OF VEHICLE CONTROL AND POSSIBLE PERSONAL INJURY OR PROPERTY DAMAGE.

10. If the toe measurement is not within the specifications of  $\frac{1}{16}'' \pm \frac{1}{32}''$  ( $0.060'' \pm 0.030''$ ), it will be necessary to adjust the toe setting. Refer to the following procedure.
  - a. Loosen the tie rod cross tube clamp bolts and locknuts.
  - b. Turn the tie rod cross tube until the specified toe-in distance is achieved.
  - c. Tighten the bolt and locknut on the tie rod cross tube to  $68 \pm 7$  foot pounds torque.



FIGURE 8-16

**5/8" Tie Rod Clamp Bolt**

It is critical to check the 5/8" tie rod clamp bolt head location to verify the clamp fasteners have sufficient clearance away from the lower shock mount at full wheel cut. The fasteners must not contact the lower shock mount.

**Tie Rod Cross Tube Slots**

It is critical to have the threaded portion of the tie rod end extend past the slots in the tie rod cross tube.

**5/8" Tie Rod Clamp Locknut**

**Tightening Torque 68 ± 7 ft. lbs.**

**Threaded Portion  
of the Tie Rod End**

**WARNING**

IT IS CRITICAL TO CHECK THE 5/8" TIE ROD CLAMP BOLT HEAD LOCATION TO VERIFY THE CLAMP FASTENERS HAVE SUFFICIENT CLEARANCE AWAY FROM THE LOWER SHOCK ABSORBER MOUNT AT FULL WHEEL CUT. THE FASTENERS MUST NOT CONTACT THE LOWER SHOCK ABSORBER MOUNT. FAILURE TO DO SO CAN CAUSE ONE OR MORE COMPONENTS TO FAIL CAUSING LOSS OF VEHICLE CONTROL AND POSSIBLE PERSONAL INJURY OR PROPERTY DAMAGE.

11. Verify the 5/8" tie rod clamp bolt head does not contact the lower shock absorber mount at full wheel cut, see Figure 8-16.
12. Repeat Steps 1-10 until the correct toe setting is achieved.



## SECTION 9 Component Replacement

### FASTENERS

Hendrickson recommends that when servicing the vehicle to replace the removed fasteners with new equivalent fasteners. Maintain correct torque values at all times. Check torque values as specified, see Hendrickson's Torque Specifications Section of this publication. If non-Hendrickson fasteners are used follow torque specifications listed in the vehicle manufacturer's service manual.

### SHOCK ABSORBERS

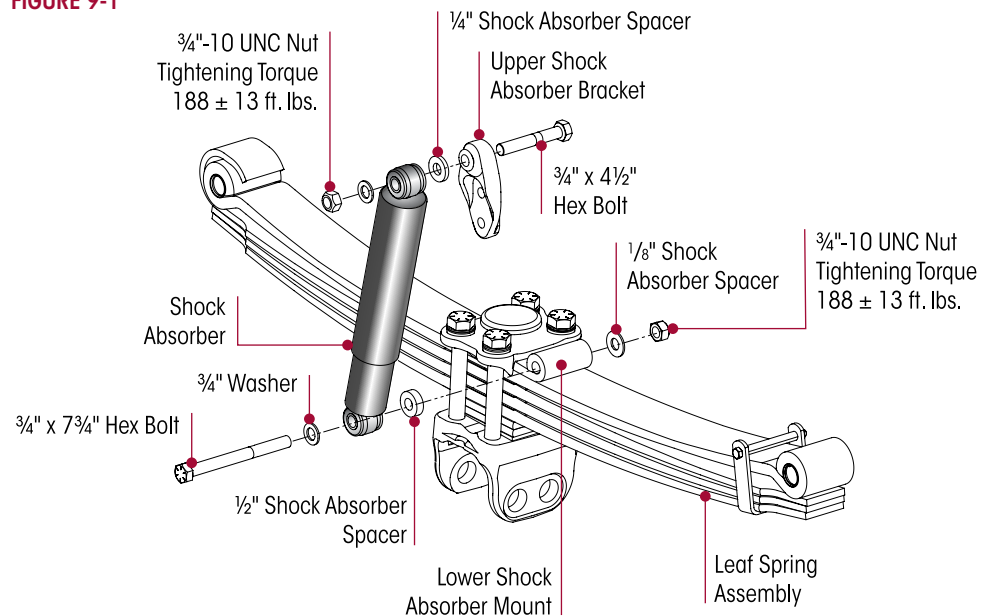
#### NOTE

It is not necessary to replace the shock absorbers in pairs if only one (1) shock absorber requires replacement.

#### DISASSEMBLY

1. Place the vehicle on a level floor.
2. Chock the wheels.
3. Remove the lower mounting bolts, fasteners, and spacer.
4. Remove the upper mounting bolts and fasteners.
5. Slide out the shock absorber.
6. Inspect the shock absorber mounting brackets and hardware for damage or wear, replace as necessary.

FIGURE 9-1



#### ASSEMBLY

1. Install the upper inboard shock absorber spacer, shock absorber and fasteners into the upper shock absorber bracket, see Figure 9-1. Snug fasteners, **DO NOT** tighten at this time.
2. Install the lower bolt from the outboard side of the leaf spring shock absorber mount and attach the washer, outboard spacer, inboard spacer and locknut, see Figure 9-1.
3. Tighten the upper and lower shock absorber eye locknuts to 188 ± 13 foot pounds torque.
4. Remove the wheel chocks.



## FRONT LEAF SPRING FRAME HANGER

### DISASSEMBLY

1. Place the vehicle on level floor.
2. Chock the wheels.
3. Raise the frame and support the vehicle with frame stands.
4. Support the front axle with a floor jack.
5. Remove the lower shock absorber mounting fasteners.

### SERVICE HINT

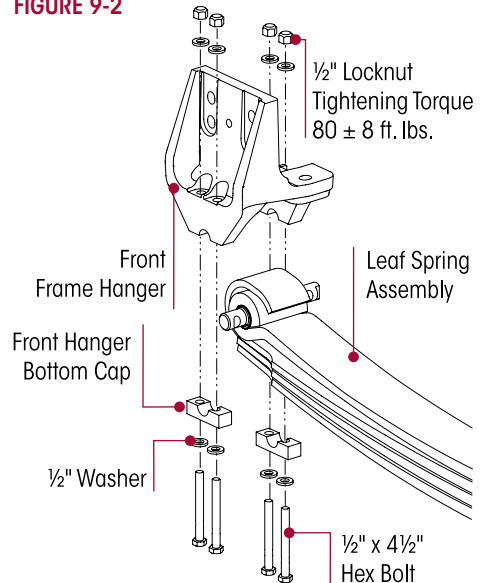
A floor jack may be required to support the axle.

6. Loosen or remove the bottom cap fasteners from the opposite side frame hanger / spring pin connection.
7. Remove the bottom cap and fasteners from the hanger being replaced, see Figure 9-2.
8. Lower the floor jack until the spring eye / spring pin clears the front frame hanger legs.
9. Remove the frame mounting fasteners from the hanger per manufacturer's guidelines.
10. Remove the hanger from the vehicle.

### ASSEMBLY

1. Install the new hanger on the frame.
2. Install new frame fasteners per manufacturer's guidelines.
3. Raise the axle into the front hanger.
4. Install the front hanger bottom cap and fasteners.
5. Tighten the 1/2" locknut to 80 ± 8 foot pounds torque.
6. Install the lower shock absorber mounting fasteners to 188 ± 13 foot pounds torque.
7. Remove the frame stands and lower frame.
8. Remove the wheel chocks.

FIGURE 9-2



## LEAF SPRING AND CLAMP GROUP ASSEMBLY

### You will need:

- Axle Collar Driver, refer to the Special Tools Section of this Publication.

### DISASSEMBLY

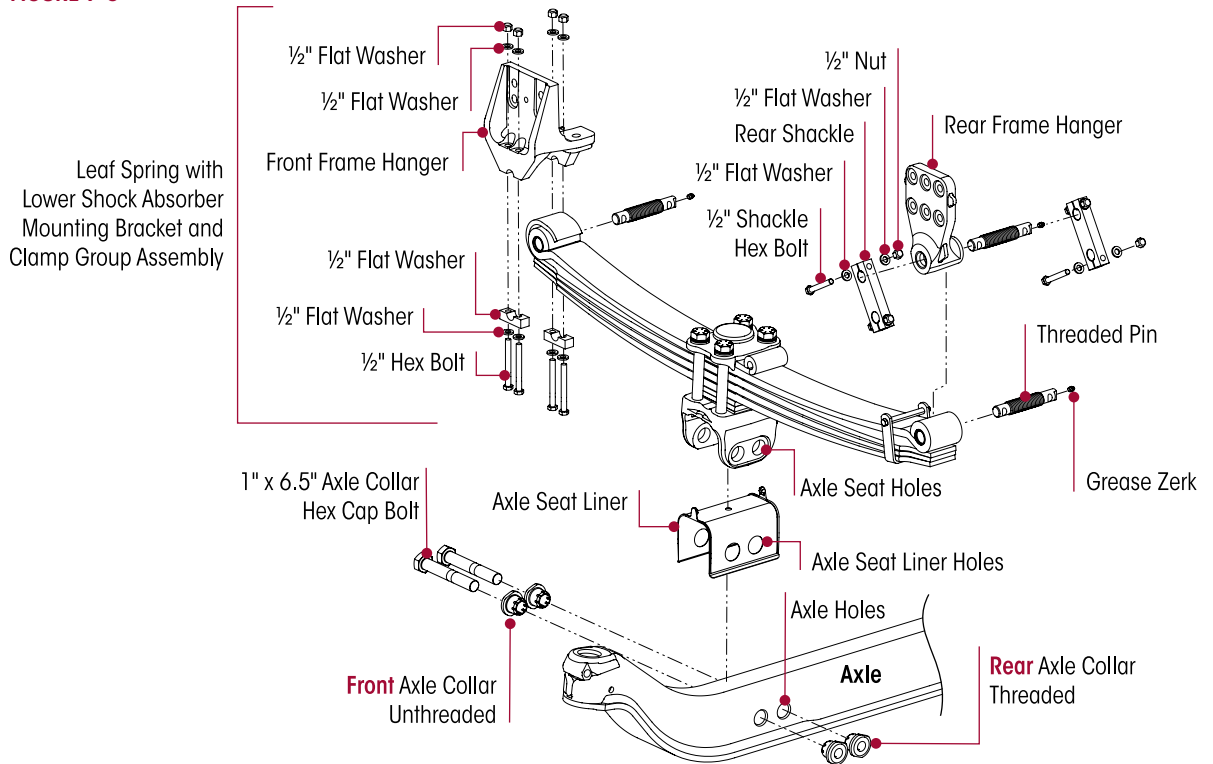
1. Place the vehicle on a level floor.
2. Chock the wheels.
3. Raise the vehicle and support the vehicle with frame stands.
4. Suspend the front axle to remove the load from leaf spring assembly.
5. Remove the tires for greater access.
6. Support the axle with a floor jack.
7. Remove the lower shock absorber mounting fasteners and discard.
8. Loosen the front hanger bottom cap fasteners on both leaf springs, see Figure 9-3, **DO NOT** remove at this time.



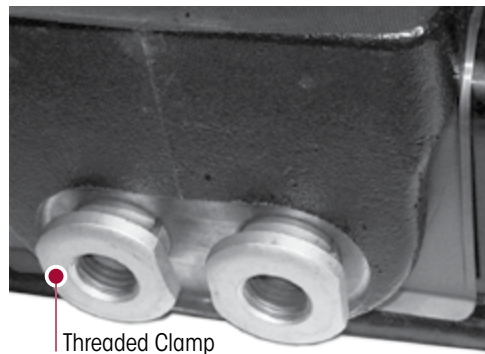


9. Remove the lower rear shackles fasteners from both leaf springs assemblies, see Figure 9-3.
10. Partially remove the axle collar bolts with a couple of threads engaged.
11. Strike the bolt heads with a hammer to dislodge and drive out the rear collars.
12. Install the collar bushing driver from the rear of the axle, see Figure 9-5.

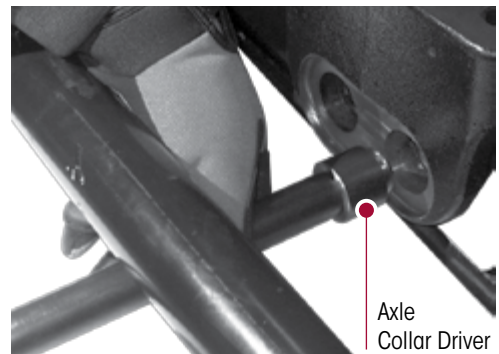
**FIGURE 9-3**



**FIGURE 9-4**



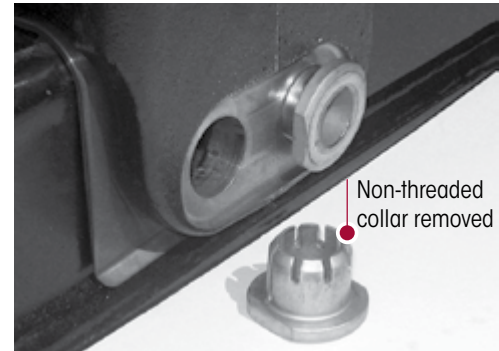
**FIGURE 9-5**



**FIGURE 9-6**



**FIGURE 9-7**





13. Strike the bushing driver to dislodge and drive out the front axle collars, Figure 9-6, until the front bushing collars are clear from the axle, see Figure 9-7.
14. Lower the axle until there is enough clearance to remove the leaf spring assembly from the axle.
15. Remove the hanger bottom cap fasteners and bottom caps on the leaf spring being removed.
16. Remove the leaf spring and clamp group assembly from the axle.

**ASSEMBLY**

**WARNING**

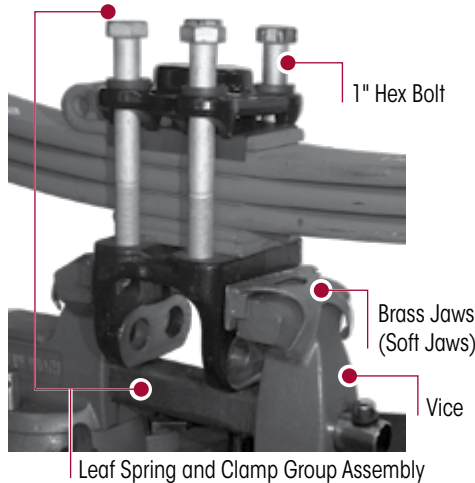
WHEN PLACING THE LEAF SPRING AND CLAMP GROUP ASSEMBLY IN A VISE IT IS NECESSARY TO PROTECT THE MACHINED SURFACES FROM GOUGES OR MARRING BY USING BRASS JAWS (SOFT JAWS) SEE FIGURE 9-8. FAILURE TO DO SO CAN CAUSE PREMATURE PART DAMAGE, DAMAGE TO THE LEAF SPRING AND CLAMP GROUP ASSEMBLY, LOSS OF WARRANTY, LOSS OF VEHICLE CONTROL, CAUSING PERSONAL INJURY OR PROPERTY DAMAGE.

**SERVICE HINT**

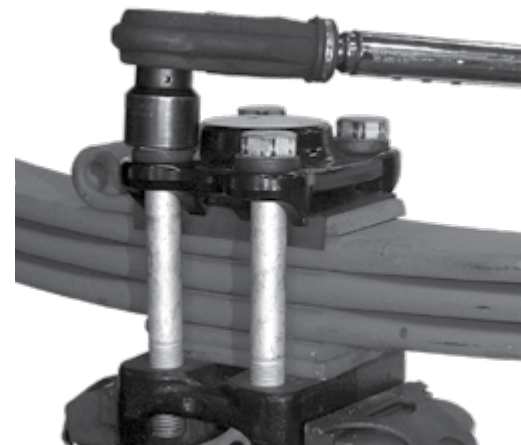
It is acceptable to mount the leaf spring and clamp group components in a soft jaw vise when performing the tightening procedure.

1. Secure the leaf spring and clamp group assembly in a suitable holding device, such as a vice with brass jaws (soft jaws), see Figure 9-8.

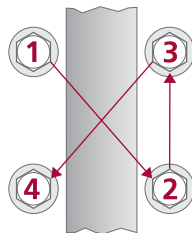
**FIGURE 9-8**



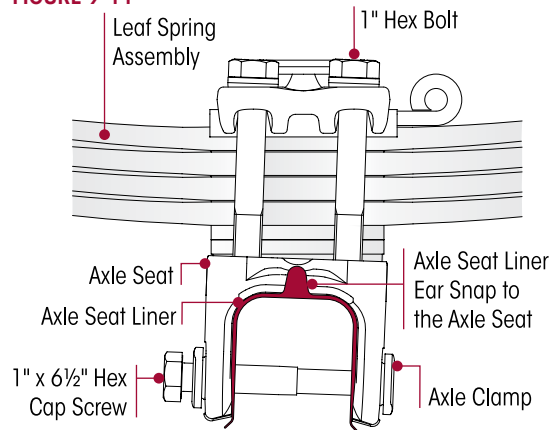
**FIGURE 9-9**



**FIGURE 9-10**



**FIGURE 9-11**



2. Ensure the clamp group hex bolts are tightened to  $600 \pm 20$  foot pounds torque in the proper pattern to achieve uniform bolt tension, see Figures 9-10 and 9-11.
3. Install the new axle seat liner under the axle seat (liner ear snap to side of axle seat), see Figure 9-11.

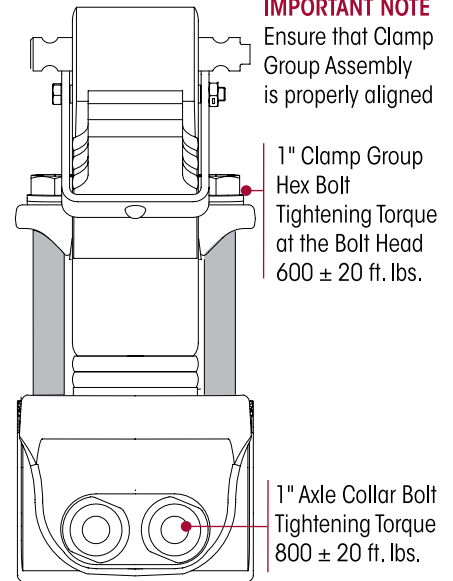
**WARNING**

THE WEIGHT OF THE LEAF SPRING AND CLAMP GROUP ASSEMBLY IS APPROXIMATELY 230 POUNDS. CARE SHOULD BE TAKEN AT REMOVAL AND INSTALLATION TO PREVENT PERSONAL INJURY OR DAMAGE TO COMPONENTS.



4. Install the new leaf spring and clamp group assembly (approximate weight 230 pounds) on the axle. Ensure the axle seat liner holes are lined up with the axle seat and axle holes, see Figures 9-3.
5. Install the non-threaded collar at the front of the axle and the threaded collars at the rear of the axle going into the axle seat, axle seat liner and axle. Tap into place with a mallet.
6. Install the new axle collar fasteners with the bolt head located on the front side of the axle.
7. Tighten both sides, left and right of the axle collar bolts in four stages, stage one 100 foot pounds, stage two 350 foot pounds, stage three 700 foot pounds and the fourth and final  $800 \pm 20$  foot pounds torque, see Figure 9-12.
8. Install the axle assembly into the front hanger and rear shackle assembly.
9. Install the spring hanger clamps, front hanger bottom cap and fasteners. Tighten fasteners to  $80 \pm 8$  foot pounds torque.
10. Install the rear shackles and fasteners and tighten fasteners to  $80 \pm 8$  foot pounds torque.
11. Raise the axle and the leaf spring clamp group assembly.
12. Install the lower shock absorber hex bolt locknuts and tighten to  $188 \pm 13$  foot pounds torque.
13. Raise the vehicle.
14. Remove the frame supports and load the front axle with the vehicle weight.
15. Install tires per the vehicle manufacturer's specifications.
16. Remove the wheel chocks.

**FIGURE 9-12**



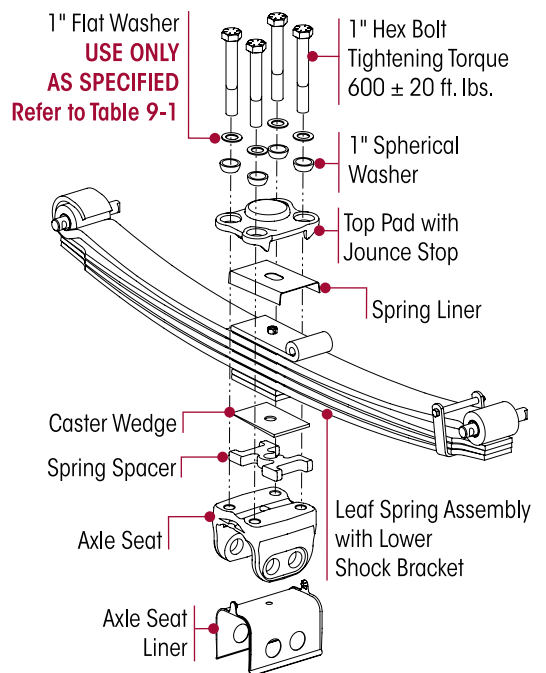
## CLAMP GROUP COMPONENTS

The clamp group instructions can be used to replace the different components in the clamp group, such as the leaf spring, axle seat or top pad.

### DISASSEMBLY

1. Remove the Leaf Spring and Clamp Group Assembly per instructions in this section.
2. Prior to removal of hex bolts, refer to Table 9-1 to determine if hex bolts are equipped with washers or not to aid in assembly.
3. Remove and discard the four (4) 1" hex bolts.
4. Remove the top pad.
5. Remove and discard all plastic leaf spring liners.
6. Remove the leaf spring assembly and leaf spring spacer.

**FIGURE 9-13**





7. Prior to removal of caster wedge, note the location and orientation, see Figure 9-13. Remove the caster wedge.
8. Prior to removal of spring spacer, note the location and orientation, see Figure 9-13. Remove the spring spacer.
9. Inspect all clamp group components for any damage, replace as necessary.

**ASSEMBLY**

1. Install caster wedge in same location and orientation as removed, see Figure 9-13.
2. Install the leaf spring onto the spring spacer.
3. Install new spring liner onto leaf spring assembly.
4. Install the top pad on top of leaf spring liner.



USE 1" FLAT WASHERS (PART NO. 22962-051) ONLY AS SPECIFIED IN TABLE 9-1 (LEAF SPRING AND CLAMP GROUP ASSEMBLY). THE TABLE LISTS DIFFERENT CONFIGURATIONS FOR THIS ASSEMBLY. FOR CERTAIN CONFIGURATIONS THE CLAMP GROUP REQUIRES THE USE OF 1" FLAT WASHERS (PART NO. 22962-051) WITH THE SPECIFIED 1" HEX BOLT LENGTH, BUT NOT IN OTHER CONFIGURATION SPECIFICATIONS IN TABLE 9-1 CAN RESULT IN IMPROPER CLAMP FORCE IN THE LEAF SPRING AND CLAMP GROUP ASSEMBLY, IMPROPER SEATING AND COMPONENT DAMAGE, WHICH CAN CAUSE LOSS OF VEHICLE CONTROL, ADVERSE VEHICLE HANDLING, PROPERTY DAMAGE AND PERSONAL INJURY.

5. Install the hex bolts and washers as noted prior to disassembly (refer to Table 9-1) into the holes on the top pad, see Figure 9-13, and hand tighten. **DO NOT** tighten to torque at this time.

TABLE 9-1

**\*Leaf Spring Assembly and Components**

Capacity	Ride Height	Leaf Spring & Clamp Group Assembly	Clamp Group Service Kit	Leaf Spring Assembly	1" Hex Bolt		1" Flat Washer (USE ONLY AS SPECIFIED)	Spring Spacer	
					Length	Part No.		Thickness	Part No.
<b>ROSENBAUER</b>									
18K	8"	80141-101	34013-278	82378-000	7"	64107-002	Not Required	---	---
	9.82"	80141-102	34013-256		9"	64107-003	22962-051	1"	79814-000
20K	8"	80141-201	34013-278	82379-000	7"	64107-002	Not Required	---	---
	9.5"	80141-202	34013-279		8.5"	64107-006	Not Required	1"	79814-000
24K	8"	80141-001	34013-254	82380-000	7.5"	64107-000	22962-051	---	---
	9"	80141-002	34013-255		8.5"	64107-006	22962-051	1"	79814-000
<b>KME</b>									
20K	10"	80888-001	34013-312	82532-000	9"	64107-003	Not Required	---	---
	11"	80888-002	34013-313		10"	64107-008	Not Required	1"	79814-000
22K	10"	80888-101	34013-312	82533-000	9"	64107-003	Not Required	---	---
	11"	80888-102	34013-313		10"	64107-008	Not Required	1"	79814-000
24K	10"	80888-201	34013-314	82534-000	9.5"	64107-007	22962-051	---	---
	11"	80888-202	34013-315		10.5"	64107-009	22962-051	1"	79814-000

**NOTE:** \*Refer to the specific Hendrickson Parts List publication for your vehicle available online at [www.hendrickson-intl.com](http://www.hendrickson-intl.com).

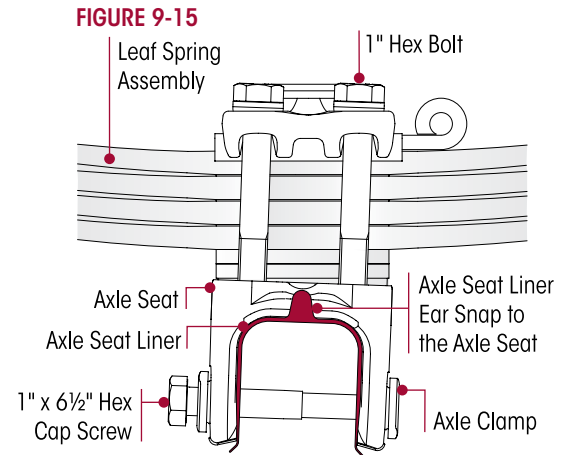
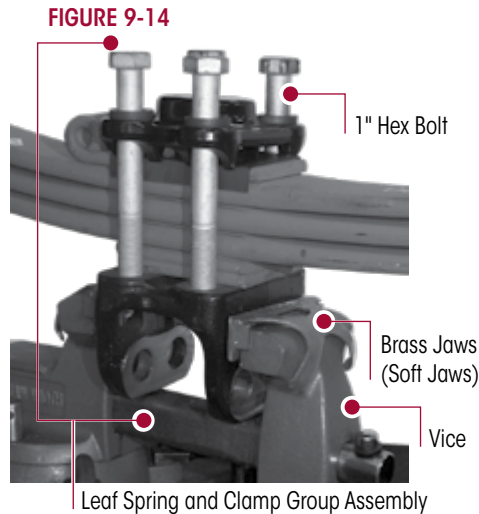


## WARNING

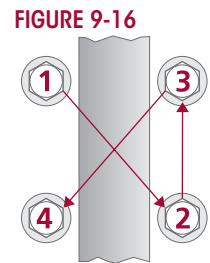
WHEN PLACING THE LEAF SPRING AND CLAMP GROUP ASSEMBLY IN A VISE IT IS NECESSARY TO PROTECT THE MACHINED SURFACES FROM GOUGES OR MARRING BY USING BRASS JAWS (SOFT JAWS) SEE FIGURE 9-14. FAILURE TO DO SO CAN CAUSE PREMATURE PART DAMAGE, DAMAGE TO THE LEAF SPRING AND CLAMP GROUP ASSEMBLY, LOSS OF WARRANTY, LOSS OF VEHICLE CONTROL, CAUSING PERSONAL INJURY OR PROPERTY DAMAGE.

## SERVICE HINT

It is acceptable to mount the leaf spring and clamp group components in a soft jaw vise when performing the tightening procedure.



6. Secure the leaf spring and clamp group assembly in a suitable holding device, such as a soft jaw vise, see Figure 9-14.
7. Tighten the clamp assembly hex bolts evenly in 100 foot pounds increments to  $600 \pm 20$  foot pounds torque in the proper pattern to achieve uniform bolt tension, see Figure 9-16.
8. Install the new axle seat liner under the axle seat (liner tabs snap to the sides of axle seat), see Figure 9-15.



## WARNING

THE WEIGHT OF THE LEAF SPRING AND CLAMP GROUP ASSEMBLY IS APPROXIMATELY 230 POUNDS. CARE SHOULD BE TAKEN AT REMOVAL AND INSTALLATION TO PREVENT PERSONAL INJURY OR DAMAGE TO COMPONENTS.

9. Install the new leaf spring and clamp group assembly (approximate weight 230 pounds) on the axle per the Leaf Spring and Clamp Group Assembly instructions in this section.

## STEERTEK NXT HIGH CAPACITY AXLE

### AXLE REMOVAL

1. Place the vehicle on level floor.
2. Chock the wheels.

## WARNING

DO NOT USE A TORCH ON AXLE COLLAR FASTENERS OR ANY OTHER PART OF THE STEERTEK NXT HIGH CAPACITY STEER AXLE SYSTEM. THE USE OF A TORCH CAN CAUSE DAMAGE TO CERTAIN STEERTEK NXT COMPONENTS THAT CAN RESULT IN THE LOSS OF VEHICLE CONTROL AND POSSIBLE PERSONAL INJURY OR PROPERTY DAMAGE.

3. Raise the frame.
4. Support the vehicle with frame stands and suspend the front axle with the shock absorbers attached.
5. Remove the front wheels, hubs, brake shoes, ABS sensors, and backing plate assembly.

6. Disconnect the drag link from the steering arm.
7. Support the axle with a suitable jack.

## WARNING

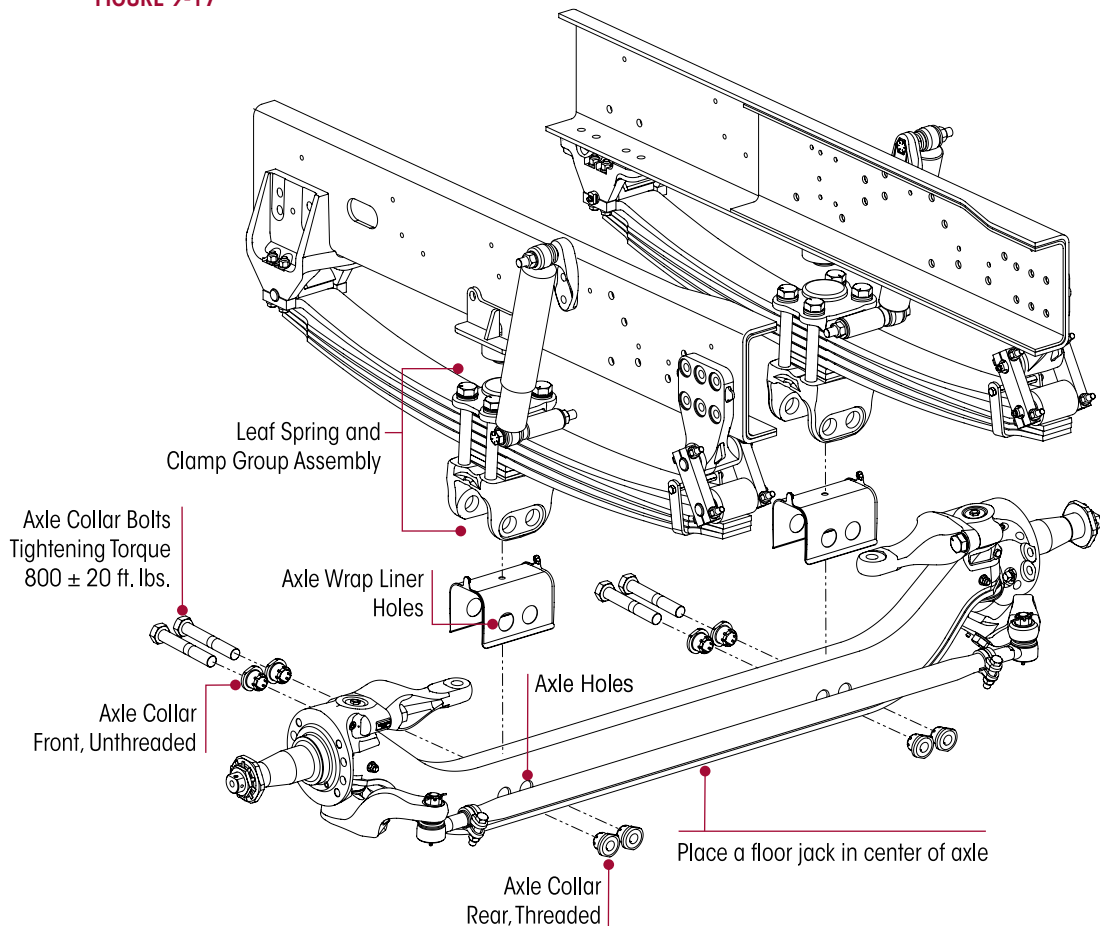
DO NOT REPAIR OR RECONDITION SUSPENSION OR AXLE COMPONENTS FOUND TO BE DAMAGED OR OUT OF SPECIFICATIONS. ALL SUCH DAMAGED OR OUT OF SPECIFICATION COMPONENTS MUST BE REPLACED. ALL MAJOR HENDRICKSON COMPONENTS ARE HEAT TREATED AND TEMPERED. STEERTEK NXT COMPONENTS CANNOT BE BENT, WELDED, HEATED, OR REPAIRED WITHOUT REDUCING THE STRENGTH OR LIFE OF THE COMPONENT. FAILURE TO FOLLOW THESE GUIDELINES CAN CAUSE LOSS OF VEHICLE CONTROL, AND POSSIBLE PERSONAL INJURY OR DEATH OR PROPERTY DAMAGE AND WILL VOID APPLICABLE WARRANTIES.

8. Remove the 1" axle collar bolts and clamps, refer Leaf Spring and Clamp Group Disassembly.
9. Lower the axle and remove from the vehicle.

## AXLE INSTALLATION

1. Place the new axle on a floor jack and position the axle under the vehicle, see Figure 9-17.
2. Install the new axle seat liner under the axle seat (liner ear snap to the side of the axle seat).
3. Raise the axle into position.
4. Ensure the axle seat liner holes are lined up with the axle seat and axle holes, see Figure 9-17.
5. Install the new axle collar fasteners with the bolt head located on the front side of the axle.

**FIGURE 9-17**

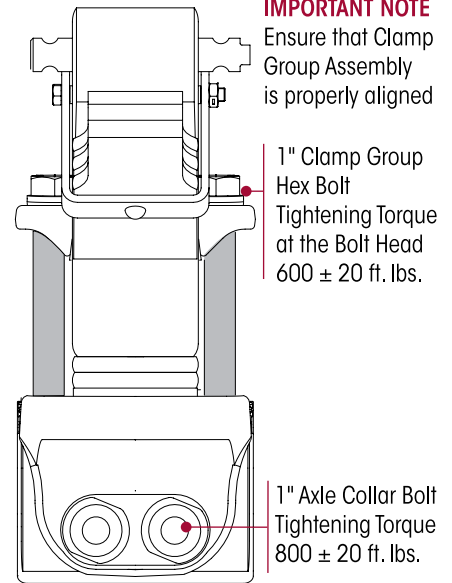




- Tighten both sides, left and right of the axle collar bolts in four stages, stage one 100 foot pounds, stage two 350 foot pounds, stage three 700 foot pounds and the fourth and final  $800 \pm 20$  foot pounds torque, see Figure 9-18.

- Install the steering knuckles, refer to the Steering Knuckle Assembly instructions in this section.
- Install the tie rod assembly in the tie rod arms.
- Install the  $\frac{7}{8}$ " hardened washers on the tie rod arm and the castle nuts. Tighten the castle nuts to  $185$  foot pounds, then rotate until the first castle slot lines up with the cotter pin bore in the tie rod end. **DO NOT** back off nut for cotter pin installation.
- Install the tie rod end cotter pin.
- Connect the drag link in the steering arm.
- Install the castle nut on the drag link taper stud. Tighten the castle nut to  $185$  foot pounds, then rotate until the first castle slot lines up with the cotter pin bore in the drag link. **DO NOT** back off nut for cotter pin installation.
- Install the drag link cotter pin.
- Install the brake backing plate assemblies and ABS sensor and torque all fasteners per manufacturer's specifications.
- Install the brakes, hubs, and wheels per the vehicle manufacturer's guidelines.
- Raise the vehicle and remove the frame supports.
- Lower the vehicle and load the front axle with the truck's weight. Remove the floor jack.
- Remove the wheel chocks.
- Fill the hubs with the proper lubricant, (see manufacturer's guidelines for recommended lubrication), if required.
- Grease the front steering components as per lubrication guidelines in the Preventive Maintenance Section of this publication.

**FIGURE 9-18**



## STEERING KNUCKLE

### DISASSEMBLY

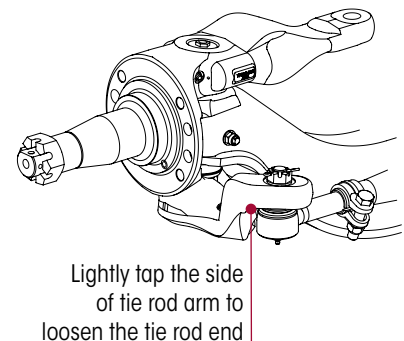
- Place the vehicle on level floor.
- Chock the wheels.
- Support the vehicle with jack stands on the axle.
- Remove the wheel and hub assembly.
- Remove the brake components from steering knuckle.

### SERVICE HINT

Lightly tap the side of the tie rod arm with a mallet to separate the tie rod end from the tie rod arm, see Figure 9-19.

- Disconnect the tie rod assembly from the tie rod arms, see Figure 9-19.
- Remove the tie rod assembly.

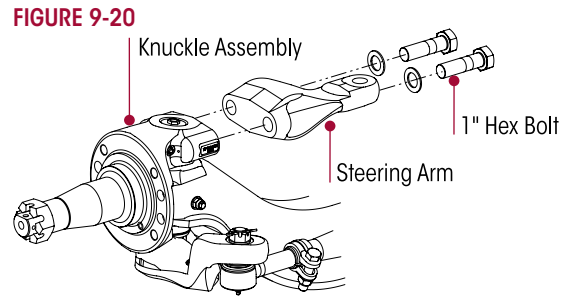
**FIGURE 9-19**





**STEERING ARM DISASSEMBLY**

1. Remove the two steering-arm-to-knuckle hex bolts from the knuckle assembly. Figure 9-20.
2. Remove the steering arm from the knuckle. If necessary, use a leather or plastic mallet to tap the outside of the arm and separate the arm from the knuckle.
3. Remove the steering arm.
4. Inspect the steering arm for cracks or damage, replace as necessary.



**TIE ROD ARM DISASSEMBLY**

**WARNING**

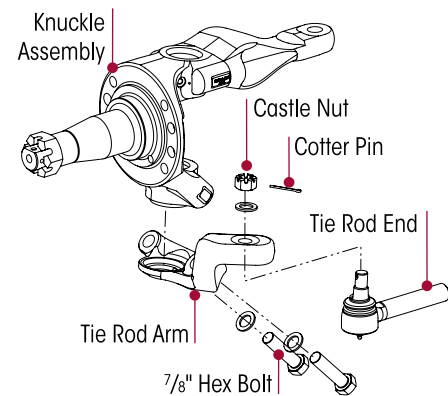
SUPPORT THE TIE ROD ASSEMBLY DURING MAINTENANCE AND SERVICE TO PREVENT SERIOUS PERSONAL INJURY AND DAMAGE TO COMPONENTS.

**CAUTION**

DO NOT HEAT THE TIE ROD ARM TO REMOVE THE TIE ROD ASSEMBLY. HEATING THE TIE ROD ARM WILL SOFTEN PARTS AND DAMAGE TO COMPONENTS WILL RESULT.

1. Remove and discard tie rod arm 7/8" fasteners.
2. Remove the tie rod arms, see Figure 9-21.

FIGURE 9-21



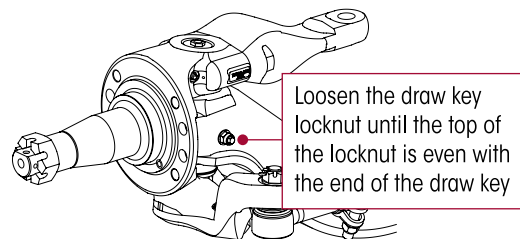
**GREASE CAP, DRAW KEY AND KINGPIN DISASSEMBLY**

You will need:

- Brass drift and hammer
- Heavy-duty King Pin Press that can generate 46,000 pounds of force and will accommodate kingpins size of 2" to 2 5/32"

1. Remove the top grease cap.
2. Remove the draw keys.
  - a. Loosen the threaded draw key locknut until the top of the locknut is even with the end of the draw key, see Figure 9-22.
  - b. Use a brass drift and a hammer to hit the end of the draw key.
  - c. Remove the nut from the draw key. Remove the draw key from the knuckle.
3. If you are not replacing the bushings, use the following procedure to prevent damaging the bushings during kingpin removal.
  - a. Use a brass drift and a hammer to remove the kingpins from the knuckle. Figure 9-23.
  - b. Remove any flaring on the drift that touches the bushings.
  - c. Wrap tape to a thickness of 1/16" (1.5 mm) onto the end of the drift.

FIGURE 9-22



**WARNING**

DO NOT HEAT THE AXLE TO REMOVE THE KINGPIN. HEATING THE AXLE WILL DAMAGE THE AXLE AND STEERING KNUCKLE COMPONENTS. FAILURE TO DO SO CAN CAUSE, LOSS OF WARRANTY, LOSS OF VEHICLE CONTROL CAUSING PERSONAL INJURY OR PROPERTY DAMAGE.





4. If the kingpin is difficult to remove, use a hydraulic kingpin press to remove the kingpin.

FIGURE 9-23

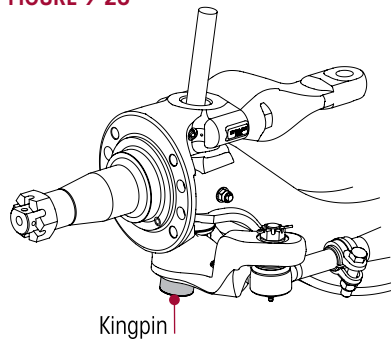
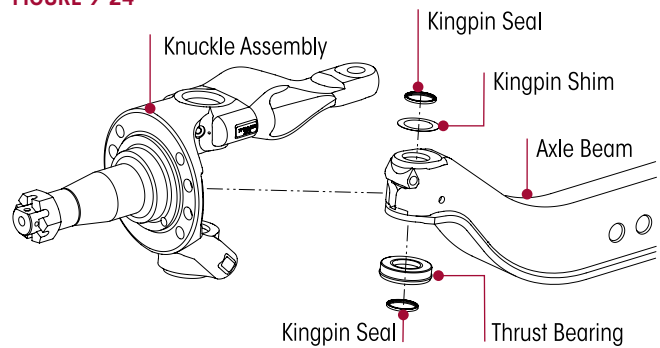


FIGURE 9-24



5. Remove the knuckle from the axle beam.

**WARNING**

WEAR GLOVES WHEN YOU REMOVE OR INSTALL SHIMS. SHIMS HAVE SHARP EDGES THAT CAN CAUSE SERIOUS PERSONAL INJURY.

6. While wearing gloves, remove the shims, the thrust bearing and the seal from the beam and / or steering knuckle. Figure 9-24.

7. Inspect the parts, refer to the Preventive Maintenance Section of this publication.

## KINGPIN BUSHING

You will need:

- Impact wrench
- Adjustable straight flute reamer with a cutting diameter must facilitate a range of 2.0" to 2.01"

Refer to the Special Tools Section of this publication for the following shop made tools:

- Kingpin Bushing / Seal Driver
- Kingpin Bushing and Seal Installer / Remover Tools

FIGURE 9-25



FIGURE 9-26



FIGURE 9-27



**REMOVAL**

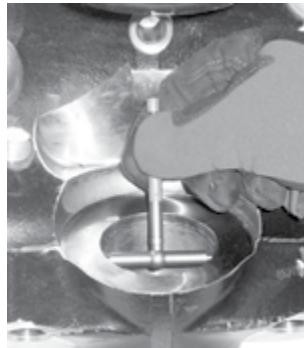
1. Place the steering knuckle on a workbench squarely supported.
2. Place the kingpin bushing and seal installer / remover tools in the steering knuckle / kingpin bore, see Figure 9-25.
3. Use a hammer and drive out the kingpin bushing, see Figure 9-26.
4. Rotate the knuckle over and repeat Steps 1-3 to remove the other kingpin bushing.
5. Clean the knuckle kingpin bores with a rotary wire wheel and inspect for reassembly, see Figure 9-27.

**STEERING KNUCKLE BORE MEASUREMENT**

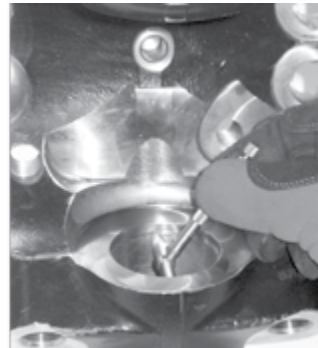
Complete the following steering knuckle bore inspection and the measurement instructions prior to installing the kingpin bushing.

1. Measure the upper knuckle bore inside diameter at two locations. Always use an inside micrometer or a telescoping gauge when taking a knuckle bore measurement. Some out-of-roundness at the top and bottom of the bore edges is acceptable. Steering knuckle bore diameter is 1.938" ± 0.003".
2. Measure the upper and lower bore in two positions and at two locations. The two positions must be 90° opposed from each other, see Figures 9-28 through 9-30. If the average measurement is more than the knuckle bore maximum diameter specification, replace the knuckle.

**FIGURE 9-28**



**FIGURE 9-29**



**FIGURE 9-30**



**INSTALLATION**

1. Install kingpin bushings from the axle side of the steering knuckle.
2. Place the new kingpin bushing into the steering knuckle bore so the seam **DOES NOT** align with the grease channel, see Figures 9-31 and 9-32.

**FIGURE 9-31**



**FIGURE 9-32**





3. Use the kingpin bushing driver to install the kingpin bushing into the **steering knuckle bore**, see Figure 9-33. Continue installation until the kingpin bushing is flush with the machined surface of the steering knuckle.
4. Remove the kingpin bushing / seal driver.
5. Install the kingpin bushing and seal installer / remover tools.
6. Continue driving the kingpin bushing into the steering knuckle until it is flush with the bottom of kingpin seal bore, see Figures 9-34 and 9-35.
7. Repeat steps for the remaining kingpin bushing.
8. Ream the bushings, see Kingpin Bushing Reaming in this section.

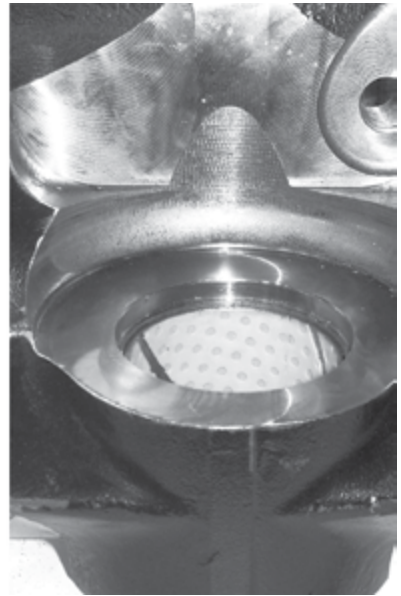
FIGURE 9-33



FIGURE 9-34



FIGURE 9-35



## KINGPIN PREPARATION AND MEASUREMENT

- Cleaning Ground and Polished Parts
  - Use a cleaning solvent to clean ground or polished parts and surfaces. **DO NOT USE GASOLINE.**
  - **DO NOT** clean ground or polished parts in a hot solution tank or with water, steam, or alkaline solutions. These solutions will cause corrosion of the parts.

## DRYING THE CLEANED PARTS

- Parts must be dried immediately after cleaning. Dry the parts with clean paper towels, clean rags, or compressed air. **DO NOT** dry bearings by spinning with compressed air. Damage to the bearings will result.

## PREVENTING CORROSION ON CLEANED PARTS

- Apply a light coating of oil to all cleaned and dried parts that are going to be reused. **DO NOT** apply oil to the brake lining or the brake drums. If parts are to be stored, apply an effective rust inhibitor to all surfaces.

## WARNING

TO HELP PREVENT SERIOUS EYE INJURY, ALWAYS WEAR PROPER EYE PROTECTION WHEN YOU PERFORM VEHICLE MAINTENANCE OR SERVICE



**WARNING**

SOLVENT CLEANERS CAN BE FLAMMABLE, POISONOUS AND CAUSE BURNS. TO HELP AVOID SERIOUS PERSONAL INJURY, CAREFULLY FOLLOW THE MANUFACTURER'S PRODUCT INSTRUCTIONS AND GUIDELINES AND THE FOLLOWING PROCEDURES:

- WEAR PROPER EYE PROTECTION.
- WEAR CLOTHING THAT PROTECTS YOUR SKIN.
- WORK IN A WELL VENTILATED AREA.
- DO NOT USE GASOLINE, SOLVENTS OR OTHER MATERIALS THAT CONTAIN GASOLINE THAT CAN EXPLODE.
- HOT SOLUTION TANKS OR ALKALINE SOLUTIONS MUST BE USED CORRECTLY. FOLLOW THE MANUFACTURER'S RECOMMENDED INSTRUCTIONS AND GUIDELINES CAREFULLY TO HELP PREVENT PERSONAL ACCIDENT OR INJURY.

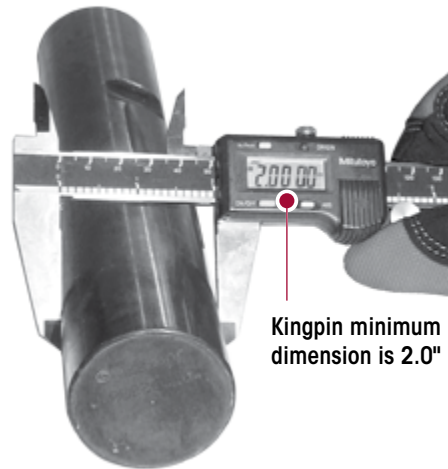
**CAUTION**

DO NOT USE HOT SOLUTION TANKS OR WATER AND ALKALINE SOLUTIONS TO CLEAN GROUND OR POLISHED PARTS. DAMAGE TO THE PARTS WILL RESULT.

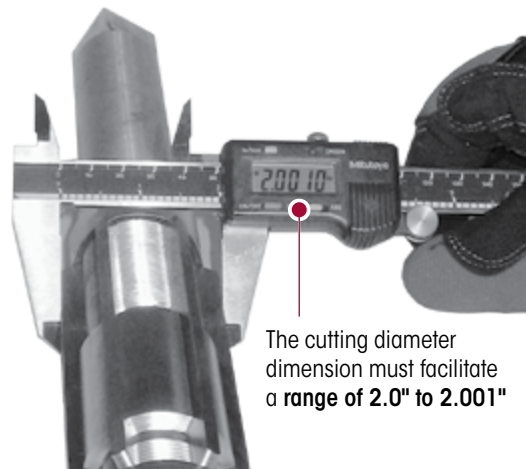
1. Inspect the kingpin for wear or damage. Use a micrometer and measure the kingpin. If the kingpin has less than 2.0" diameter, replacement is necessary, see Figure 9-36.
2. Set up the adjustable straight flute reamer to match kingpin dimension, see Figure 9-37. The dimension of cutting diameter must facilitate a range of 2.0" to 2.001".

**Kingpin minimum dimension is 2.0"**

**FIGURE 9-36**



**FIGURE 9-37**



**KINGPIN BUSHING REAMING**

**WARNING**

WHEN INSTALLING STEERING KNUCKLE COMPONENTS IN A VISE IT IS NECESSARY TO PROTECT THE MACHINED SURFACES FROM GOUGES OR MARRING BY USING BRASS JAWS, SEE FIGURE 9-38. FAILURE TO DO SO CAN CAUSE PREMATURE PART DAMAGE, DAMAGE TO THE STEERING KNUCKLE COMPONENTS, LOSS OF WARRANTY, LOSS OF VEHICLE CONTROL, CAUSING PERSONAL INJURY OR PROPERTY DAMAGE.

**WARNING**

PRIOR TO INSTALLATION ENSURE THAT ALL RESIDUAL LOCTITE® MATERIAL IS REMOVED FROM THE MOUNTING BOLTS AND THE THREAD BORES IN THE UPPER STEERING KNUCKLES, AND NEW LOCTITE 277 OR EQUIVALENT IS APPLIED TO HELP ENSURE THAT THE BOLTS SUSTAIN THE PROPER TORQUE REQUIREMENT. FAILURE TO DO SO CAN CAUSE LOSS OF VEHICLE CONTROL RESULTING IN PERSONAL INJURY OR PROPERTY DAMAGE.

**NOTE**

Bushing size is to be 0.001" larger than the kingpin size.

1. Place the knuckle in a vise with brass jaws (soft jaws), see Figure 9-38.
2. Install the pilot in the lower kingpin bore.



## CAUTION

REAM THE KINGPIN BUSHINGS WITH AN ADJUSTABLE STRAIGHT FLUTE REAMER. (SEE SPECIAL TOOLS SECTION OF THIS PUBLICATION) DO NOT HONE OR BURNISH THE KINGPIN BUSHINGS. HONING OR BURNISHING WILL DAMAGE THE BUSHINGS AND VOID ANY APPLICABLE WARRANTY.

3. Install the adjustable straight flute reamer into the pilot.
4. Slide the adjustable straight flute reamer into the upper bushing and into the pilot until the reamer blades touch the bushing.
5. Rotate the adjustable straight flute reamer with a light **DOWNWARD** pressure. **DO NOT** apply too much force. Rotate the reamer smoothly, see Figure 9-39.

FIGURE 9-38

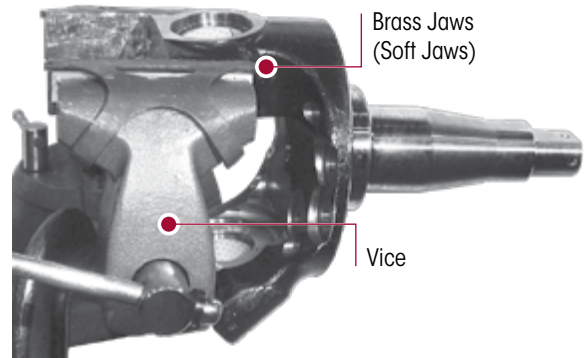


FIGURE 9-39

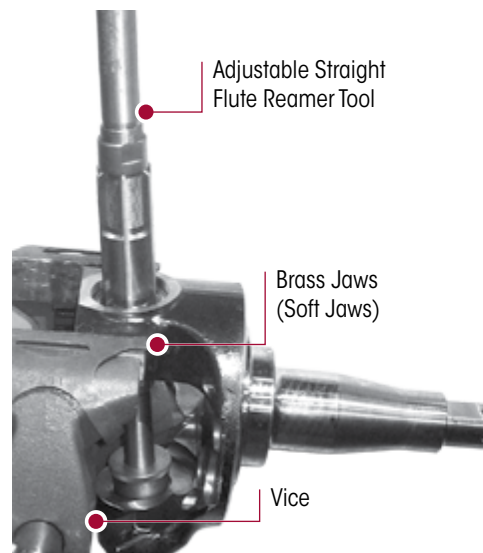
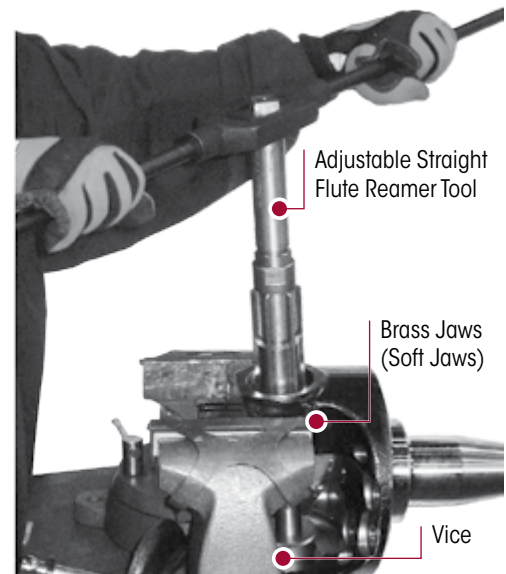


FIGURE 9-40



6. Turn the knuckle over in the vise and repeat Steps 2-5 for the other kingpin bushing, see Figures 9-39 and 9-40.

## SERVICE HINT

If the adjustable straight flute reamer must be removed through the bushing. Rotate the tool in the opposite cutting direction.

7. Clean all material from the bushings.
8. Lightly lubricate the new the kingpin with penetrating oil and slide into the steering knuckle bore to ensure the kingpin fits properly into the kingpin bushings.

## KINGPIN SEAL INSTALLATION

1. Place the steering knuckle assembly on a suitable workbench.
2. Lay the kingpin seal into the bore of the steering knuckle. Ensure the lip of the kingpin seal faces toward the axle, see Figure 9-41.
3. Use the kingpin bushing / seal driver tool and drive the kingpin seal firmly into the steering knuckle assembly with a hammer.
4. Use a kingpin bushing and seal installer / remover tools with a hammer until it bottoms out in the kingpin bore, see Figure 9-42.



**FIGURE 9-41**

Ensure the lip of the Kingpin Seal is facing **towards** the axle.



**FIGURE 9-42**

Kingpin seal bottoms out in the kingpin bore



**STEERING KNUCKLE INSTALLATION**

**FIGURE 9-43**

1. Clean the kingpin bores of the axle beam.
2. Install the thrust bearing assembly on the inner steering knuckle. The seal must face **UPWARD** toward the beam. The top inner diameter will contact the bottom of the axle beam, see Figures 9-43 and 9-44.

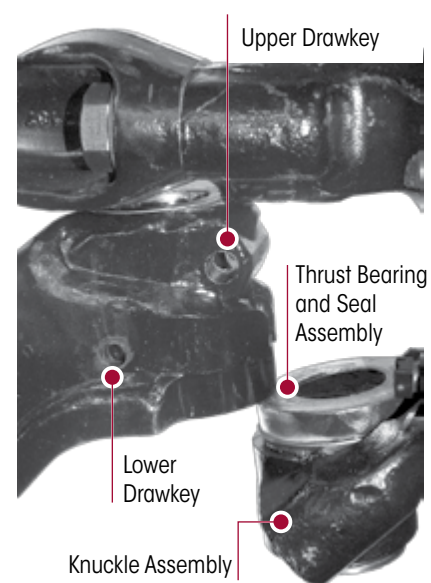


**WARNING**

WEAR GLOVES WHEN YOU INSTALL THE SHIMS. SHIMS HAVE SHARP EDGES THAT CAN CAUSE SERIOUS PERSONAL INJURY.

3. Place the knuckle onto the axle beam, see Figure 9-44.
4. Place a pry bar between the steering arm boss and the axle beam. Lift the knuckle and slide the shim pack between the top of the beam and the steering knuckle, see Figure 9-45.
5. Align all the steering knuckle components within the kingpin bore. If the bores are not aligned, the components will be damaged during kingpin installation.
6. Remove the pry bar.
7. Apply the multi-purpose grease onto the bottom half of the kingpin prior to kingpin installation onto the steering knuckle.

**FIGURE 9-44**



**CAUTION**

VERIFY THAT THE DRAW KEY IS INSTALLED COMPLETELY OR THE LOCKNUT IS TIGHTENED TO  $35 \pm 5$  FOOT POUNDS TORQUE. IF NOT INSTALLED CORRECTLY, THE KINGPIN AND THE AXLE BEAM WILL BE DAMAGED.

8. Install the kingpin into the top of the knuckle and through the area where the shims are located, see Figures 9-46 and 9-47. **DO NOT** force the kingpin through the upper kingpin bushing. Ensure the word **TOP** is facing up, see Figure 9-48.



FIGURE 9-45

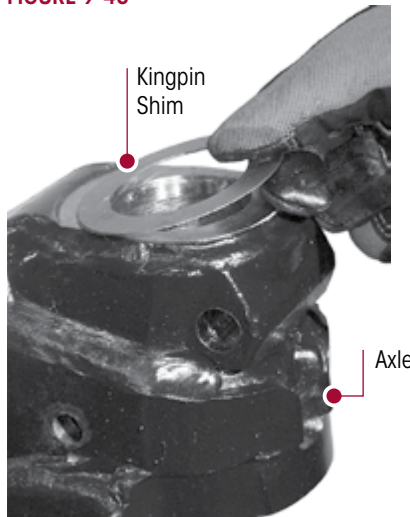


FIGURE 9-46

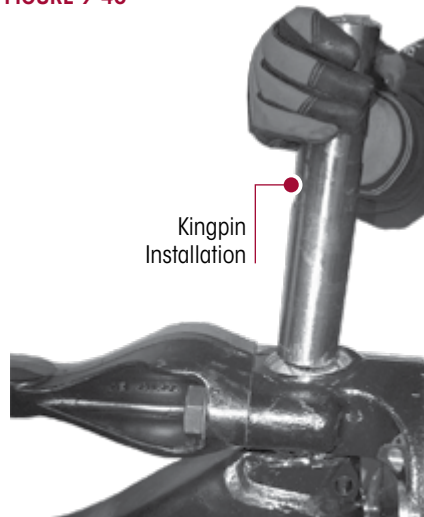
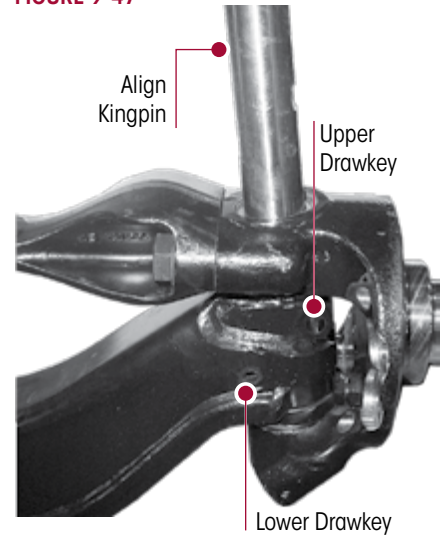


FIGURE 9-47



9. Rotate the kingpin and slide in until the two draw key slots align with the axle draw key bores, see Figure 9-49 and 9-50.
10. If required, use a hammer and a brass drift to apply direct force to the kingpin for seating into the lower steering knuckle bore, see Figure 9-49.
11. Seat the upper draw key into the front of the axle beam, see Figure 9-50.
12. Seat the lower draw key into the back of the axle beam by striking it with a hammer and drift, see Figure 9-49. The draw keys must align with the slots of the kingpin.
13. Install draw key locknuts, Snug, **DO NOT** tighten torque until after the steering knuckle vertical end play procedure is completed.

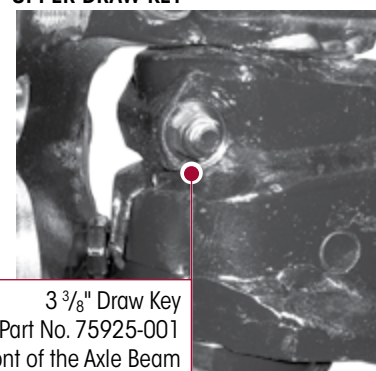
FIGURE 9-48



FIGURE 9-49  
LOWER DRAW KEY



FIGURE 9-50  
UPPER DRAW KEY



## MEASURE STEERING KNUCKLE VERTICAL END PLAY

1. Turn the knuckle to the straight-ahead position.
2. Attach a dial indicator to the axle. Place the tip onto the top of the steering knuckle.
3. Set the dial indicator to **zero**, see Figure 9-51.



4. Use one of the following methods to measure the vertical clearance.
  - Place a pry bar between the knuckle and the top of the axle center. Pry the knuckle up and measure the vertical end play.
  - Place a block of wood and a hydraulic jack under the bottom of the knuckle. Raise the knuckle until the pointer on the dial indicator stops, see Figure 9-51.
5. Record dial indicator reading.
  - If the knuckle binds or **zero** end play is measured, remove shims from the shim pack.
  - If the reading is more than the correct specification shown in Table 9-2, add shims to the shim pack.

FIGURE 9-51

Ensure the tip of the dial indicator is on the top of the upper steering knuckle and not on the grease cap

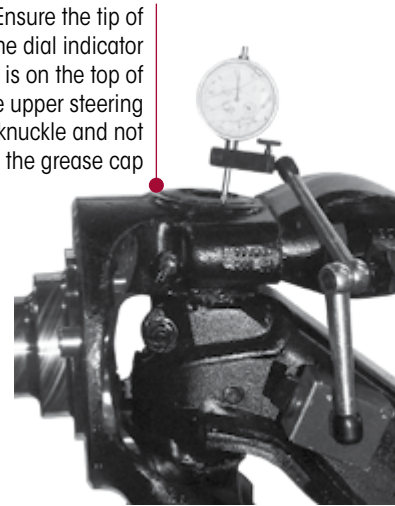


TABLE 9-2

END PLAY SPECIFICATIONS

<b>New or Rebuilt Axles:</b>	0.001-0.010 inch (0.025-0.254 mm)
<b>In-service Axles:</b>	0.001-0.030 inch (0.025-0.762 mm)

6. Tighten upper and lower draw key locknuts to  $\boxed{35} \pm 5$  foot pounds torque.

GREASE CAP INSTALLATION



TAKE CARE WHEN YOU USE LOCTITE ADHESIVE TO AVOID SERIOUS PERSONAL INJURY. READ THE MANUFACTURER'S INSTRUCTIONS BEFORE USING THIS PRODUCT. FOLLOW THE INSTRUCTIONS CAREFULLY TO PREVENT IRRITATION TO THE EYES AND SKIN. IF LOCTITE® ADHESIVE MATERIAL GETS INTO YOU EYES, FOLLOW THE MANUFACTURER'S EMERGENCY PROCEDURES. HAVE YOUR EYES CHECKED BY A PHYSICIAN AS SOON AS POSSIBLE.

NOTE

If reusing a grease cap, ensure to apply the Loctite Straight Thread Sealant™ (STS) all around the threads (apply to a minimum of 3 threads), see Figure 9-52.

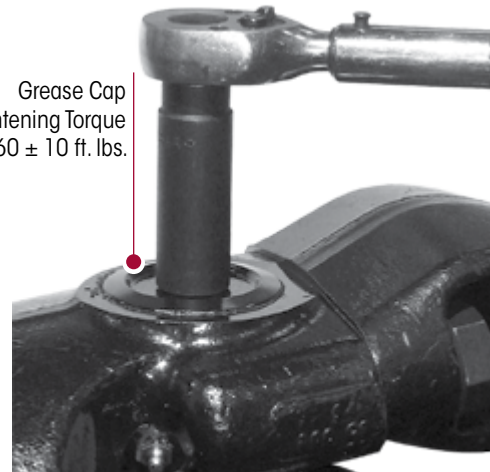
FIGURE 9-52

Apply Loctite STS to a minimum of three grease cap threads



FIGURE 9-53

Grease Cap Tightening Torque  $60 \pm 10$  ft. lbs.



1. Ensure Loctite STS is applied to a minimum of three grease cap threads (note: new grease caps have Loctite STS pre-applied).
2. Install the threaded grease caps onto the top of the knuckle.





3. Tighten the grease caps to  $\mathbb{N}$  60  $\pm$  10 foot pounds, see Figure 9-53.
4. Remove the bottle jack and continue assembling the wheel ends.

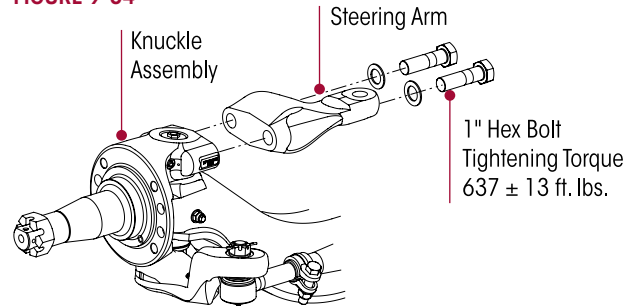
## STEERING ARM INSTALLATION

### WARNING

TAKE CARE WHEN YOU USE LOCTITE ADHESIVE TO AVOID SERIOUS PERSONAL INJURY. READ THE MANUFACTURER'S INSTRUCTIONS BEFORE USING THIS PRODUCT. FOLLOW THE INSTRUCTIONS CAREFULLY TO PREVENT IRRITATION TO THE EYES AND SKIN. IF LOCTITE ADHESIVE MATERIAL GETS INTO YOU EYES, FOLLOW THE MANUFACTURER'S EMERGENCY PROCEDURES. HAVE YOUR EYES CHECKED BY A PHYSICIAN AS SOON AS POSSIBLE.

1. Use a tap to remove old Loctite adhesive from the internal threads of the knuckle.
2. Use new steering arm hex bolts and apply Loctite 680 adhesive. Ensure to cover at least half of the thread area.
3. Insert the hex bolts through the steering arm. Hand-start the bolts into the knuckle assembly, see Figure 9-54.
4. Tighten the steering arm hex bolts to  $\mathbb{N}$  637  $\pm$  13 foot pounds torque.

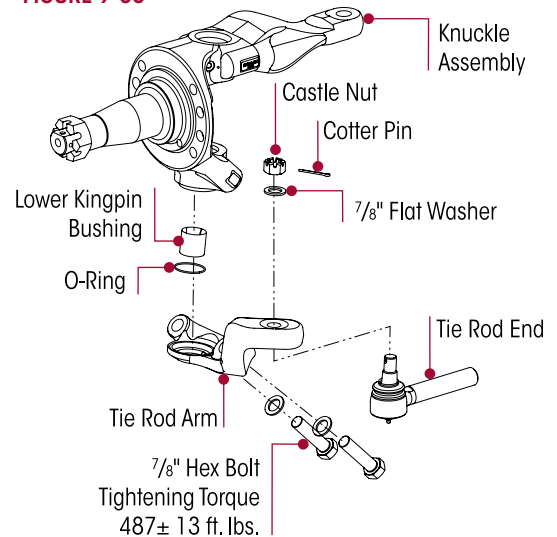
FIGURE 9-54



## TIE ROD ARM INSTALLATION

1. Install new O-ring on the bottom of the steering knuckle.
2. Use a tap to remove old Loctite adhesive from the internal threads of the knuckle.
3. Use new tie rod arm hex bolts and apply Loctite 680 adhesive. Ensure to cover at least half of the thread area.
4. Lubricate O-ring with grease and install tie rod arm on the bottom of the steering knuckle.
5. Insert the tie rod arm hex bolts through the tie rod arm and into the steering knuckle. Hand-start the bolts into the knuckle assembly, see Figure 9-55.
6. Tighten the tie rod arm bolts to  $\mathbb{N}$  487  $\pm$  13 foot pounds torque.
7. Install brake torque plate.

FIGURE 9-55



### IMPORTANT NOTE

It is critical to apply Loctite to the three (3) brake torque plate bolts to ensure that these bolts sustain the proper torque requirement of steering knuckle assembly.

8. Apply Loctite Red 262 to the torque plate bolts prior to installation into the torque plate.
9. Tighten torque plate bolts to  $\mathbb{N}$  400  $\pm$  50 foot pounds torque.
10. Install the tie rod end into the tie rod arm, see Figure 9-55.
11. Tighten the castle nuts to  $\mathbb{N}$  185 foot pounds torque then rotate the castle nut to the next castle slot and install cotter pin, see Figure 9-55.



12. Install the drag link into the steering arm and tighten to the vehicle manufacturer's specifications.
13. Install wheel ends and tires.
14. Remove jack and safety stands.
15. Grease steering knuckles with the vehicle on the floor.
16. Remove the wheel chocks.

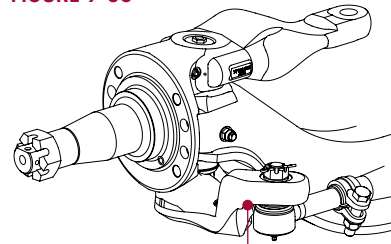
**TIE ROD ENDS AND CROSS TUBE**

**NOTE:** Hendrickson supplies different tie rod configurations. Prior to ordering, locate the part number on the tie rod tube, for additional information see Technical Bulletin SEU-0223 or contact Hendrickson Tech Services.

**DISASSEMBLY**

1. Chock the wheels.
2. Position the steer axle tires straight ahead.
3. Remove the cotter pin and castle nut.
4. Lightly tap the side of the tie rod arm to loosen the tie rod end from the tie rod arm, see Figure 9-56.
5. Repeat to Steps 3 and 4 to remove the other tie rod end.
6. Remove the cross tube and tie rod ends from the vehicle.

**FIGURE 9-56**



7. Mount the cross tube in a soft jaw vice.
8. Remove the hardware from the clamp on the cross tube.
9. Count the exposed threads on the tie rod end being replaced.
10. Remove the tie rod end from the cross tube.

Lightly tap the side of tie rod arm to loosen the tie rod end

**WARNING**

DO NOT HEAT THE CROSS TUBE WITH A TORCH TO FACILITATE THE REMOVAL OF THE TIE ROD END. THE USE OF SUCH HEAT CAN ADVERSELY AFFECT THE STRENGTH OF THE CROSS TUBE. A COMPONENT DAMAGED IN THIS MANNER WILL RESULT IN LOSS OF WARRANTY, AND CAN RESULT IN THE AND LOSS OF VEHICLE CONTROL, AND POSSIBLE PERSONAL INJURY OR PROPERTY DAMAGE.

11. If the opposing tie rod end is being replaced repeat Steps 8 through 10.
12. Inspect the cross tube for dents, cracks, or thread damage. Replace the cross tube if needed.

**ASSEMBLY**

1. Lubricate the new tie rod end threads with Anti-Seize.

**NOTE** When installing the cross tube the thread direction of the tie rod ends are as follows:

- A right hand threaded tie rod end will be installed into the right side tie rod arm.
- A left hand threaded tie rod end will be installed into the left side tie rod Arm.

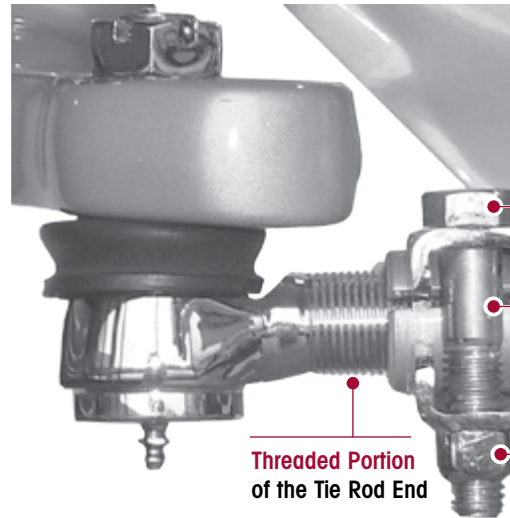
2. Install the new tie rod end into the cross tube, leaving the same amount of threads exposed that were counted on the failed tie rod end prior to removal.

**WARNING**

THE THREADED PORTION OF THE TIE ROD END MUST EXTEND PAST THE SLOTS INTO THE TIE ROD CROSS TUBE, SEE FIGURE 9-57. FAILURE TO DO SO CAN CAUSE COMPONENT DAMAGE, LOSS OF VEHICLE CONTROL AND POSSIBLE PERSONAL INJURY OR PROPERTY DAMAGE.



FIGURE 9-57



**5/8" Tie Rod Clamp Bolt**

It is critical to check the 5/8" tie rod clamp bolt head location to verify the clamp fasteners have sufficient clearance away from the lower shock mount at full wheel cut. The fasteners must not contact the lower shock mount.

**Tie Rod Cross Tube Slots**

It is critical to have the threaded portion of the tie rod end extend past the slots in the tie rod cross tube.

**Threaded Portion  
of the Tie Rod End**

**5/8" Tie Rod Clamp Locknut**

**Tightening Torque 68 ± 7 ft. lbs.**

**WARNING**

IT IS CRITICAL TO CHECK THE 5/8" TIE ROD CLAMP BOLT HEAD LOCATION TO VERIFY THE CLAMP FASTENERS HAVE SUFFICIENT CLEARANCE AWAY FROM THE LOWER SHOCK ABSORBER MOUNT AT FULL WHEEL CUT. THE FASTENERS MUST NOT CONTACT THE LOWER SHOCK ABSORBER MOUNT. FAILURE TO DO SO CAN CAUSE ONE OR MORE COMPONENTS TO FAIL CAUSING LOSS OF VEHICLE CONTROL AND POSSIBLE PERSONAL INJURY OR PROPERTY DAMAGE.

3. Replace the opposing tie rod end if necessary by repeating Steps 1 and 2.

**WARNING**

DO NOT HEAT THE CROSS TUBE WITH A TORCH TO ROTATE THE CROSS TUBE IN THE TIE ROD END. THE USE OF SUCH HEAT CAN ADVERSELY AFFECT THE STRENGTH OF THE CROSS TUBE. A COMPONENT DAMAGED IN THIS MANNER WILL RESULT IN LOSS OF WARRANTY, AND CAN RESULT IN THE LOSS OF VEHICLE CONTROL, AND POSSIBLE PERSONAL INJURY OR PROPERTY DAMAGE.

4. It is critical that the cross tube rotate in the opposing tie rod end, even if it is not replaced.
5. Install the tie rod end into the tie rod arm.
6. Tighten the castle nuts to 185 foot pounds, torque then rotate the castle nut to the next castle slot and install cotter pin.
7. Grease the tie rod ends. Refer to the Lubrication Table 7-1 for required lubricant in the Preventive Maintenance Section of this publication.
8. Set the toe, refer to the Toe Adjustment Procedure in the Alignment & Adjustments Section of this publication.

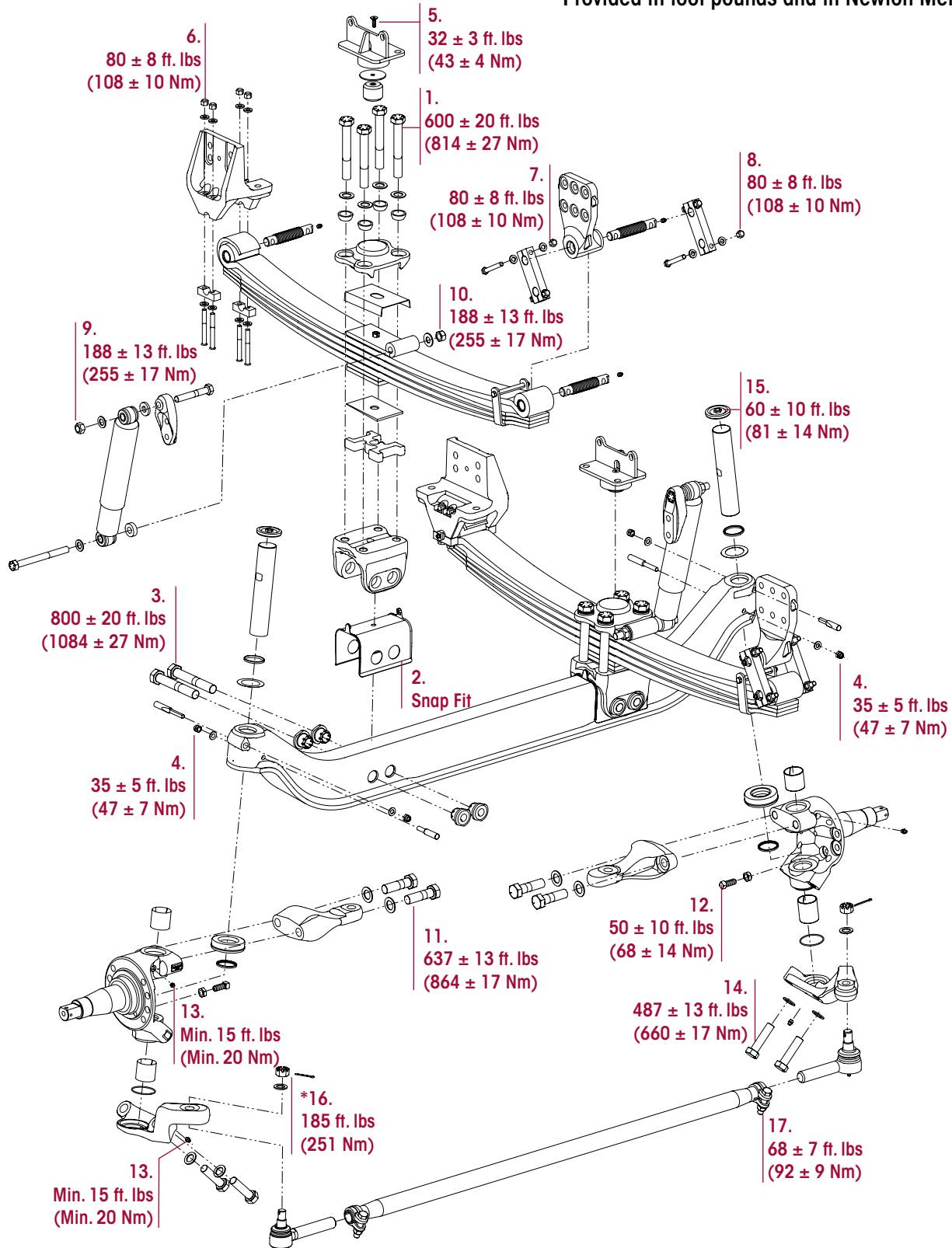
## AIR DISC BRAKES • DRUM BRAKES ASSEMBLY

Brake components are not supplied by Hendrickson for aftermarket service purposes. For more information and assistance with service, maintenance and rebuild instructions on these components, refer to specific Parts List for your suspension system, see Parts List Section of this publication.



# SECTION 10 Torque Specifications

HENDRICKSON RECOMMENDED TORQUE VALUES  
Provided in foot pounds and in Newton Meters





STEERTEK NXT High Capacity for Fire and Rescue Vehicles

HENDRICKSON RECOMMENDED TORQUE SPECIFICATIONS					
NO.	COMPONENT	FASTENER		TORQUE VALUE	
		QUANTITY	SIZE	Foot Pounds	Newton Meters
	Frame fasteners are furnished and installed by the vehicle manufacturer. Vehicle manufacturer may use an equivalent HUCK fastener at frame mount.				
	<b>WARNING: ENSURE CLAMP GROUP IS ALIGNED PROPERLY PRIOR TO TIGHTENING HARDWARE. FAILURE TO DO SO CAN CAUSE LOSS OF VEHICLE CONTROL, PROPERTY DAMAGE OR PERSONAL INJURY.</b>				
1	Clamp Group Hex Bolt	8	1"-8 UNC	600 ± 20	814 ± 27
2	Axle Seat Liner	2		Snap Fit	Snap Fit
3	Axle Collar at the Bolt Head	4	1"-8 UNC	800 ± 20	1084 ± 27
4	Kingpin Draw Key Nut	4	7/8"-14 UNC	35 ± 5	47 ± 7
5	Jounce Stop	2	M10	32 ± 3	43 ± 4
6	Front Frame Hanger to Leaf Spring Assembly	8	1/2"-20 UNC	80 ± 8	108 ± 10
7	Rear Shackle to Rear Frame Hanger	4	1/2"-20 UNC	80 ± 8	108 ± 10
8	Rear Shackle to Leaf Spring Assembly	4	1/2"-20 UNC	80 ± 8	108 ± 10
9	Upper Shock Absorber	2	3/4"-10 UNC	188 ± 13	255 ± 17
10	Lower Shock Absorber	2	3/4"-10 UNC	188 ± 13	255 ± 17
11	Knuckle Assembly to Steering Arm	4	1"-14 UNF	637 ± 13	864 ± 17
12	Knuckle / Axle Wheel Stop Bolt	2	5/8" Jam Nut	50 ± 10	68 ± 14
13	Grease Zerk	4		Minimum of 15	Minimum of 20
14	Knuckle Assembly to Tie Rod Arm	4	7/8"-14 UNF	487 ± 13	660 ± 17
15	Grease Cap	2	1/2"	60 ± 10	81 ± 14
16	Tie Rod Ends to Tie Rod Arms	2	7/8" Castle Nut	*185	*251
17	Tie Rod Tube to Tie Rod Ends	2	5/8"	68 ± 7	92 ± 9
<p>• All hardware 1/4" and greater is Grade 8 with no additional lubrication.</p> <p><b>NOTE:</b> Torque values shown in this publication apply only if Hendrickson supplied fasteners are used. If non Hendrickson fasteners are used, follow the torque specification listed in the vehicle manufacturer's service manual.</p> <p>* Tighten to 185 foot pounds torque, advance castle nut to the next hex face to install cotter pin. <b>DO NOT</b> back off nut for cotter pin installation.</p>					

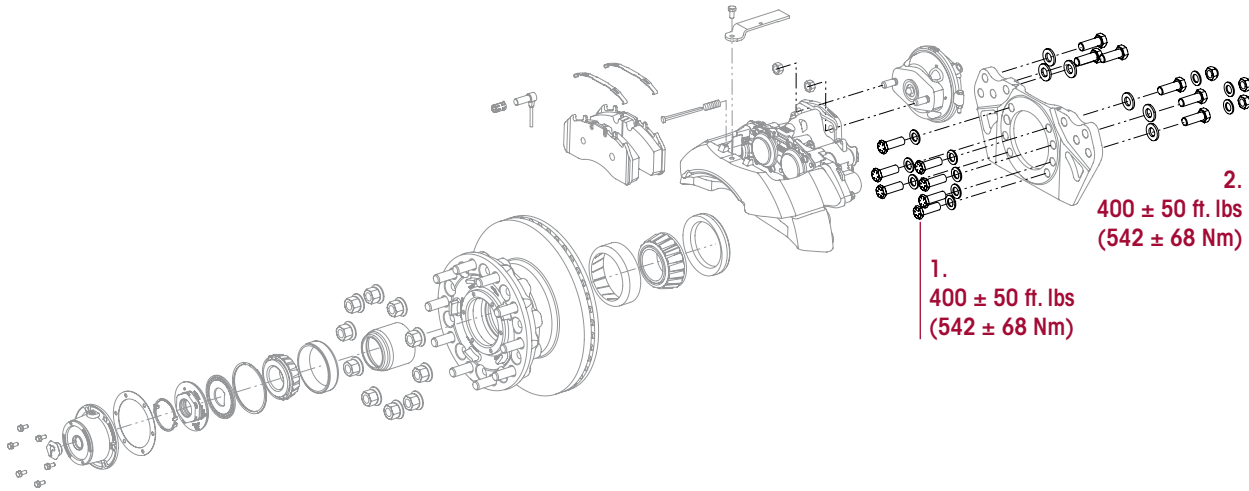
Additional brake component part and service information is referenced in the Parts List. Refer to the specific parts list for your vehicle available online at [www.hendrickson-intl.com/Truck/Fire-Rescue/STEERTEK-NXT-Fire](http://www.hendrickson-intl.com/Truck/Fire-Rescue/STEERTEK-NXT-Fire)



HENDRICKSON RECOMMENDED TORQUE VALUES  
 Provided in foot pounds and in Newton Meters

HENDRICKSON RECOMMENDED TORQUE SPECIFICATIONS

Air Disc Brakes



NO.	COMPONENT	FASTENER		*TORQUE VALUE	
		QUANTITY	SIZE	Foot Pounds	Newton Meters
1.	Torque Plate Hex Bolts to Knuckle	8	3/4"	400 ± 50	542 ± 68
2.	Torque Plate Hex Nuts	6	3/4"	400 ± 50	542 ± 68

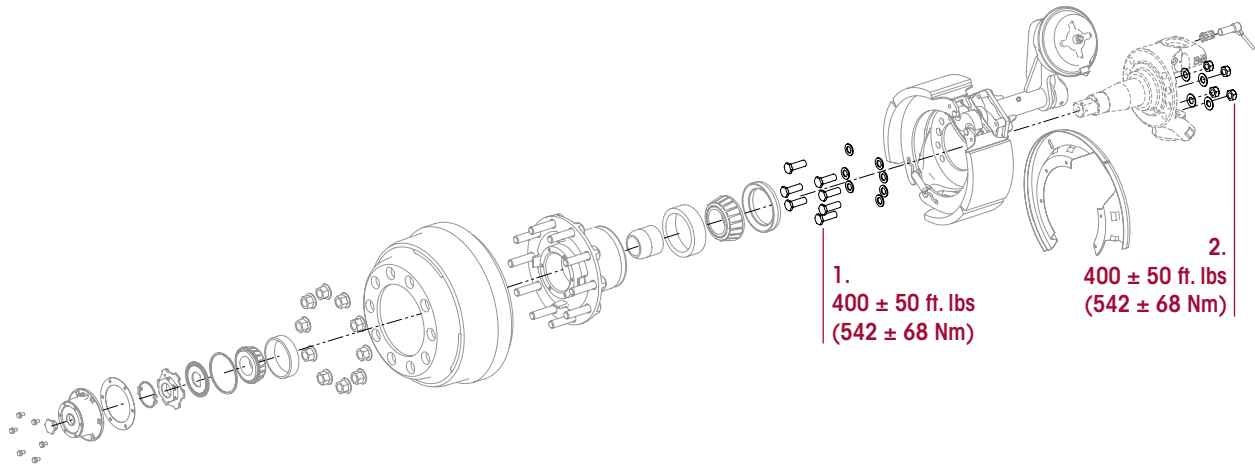
**NOTE:** For fasteners not supplied by Hendrickson, follow the torque specification listed in the vehicle manufacturer's or the component manufacturer's service manual. Refer to the Parts List publication for your specific vehicle available online at [www.hendrickson-intl.com](http://www.hendrickson-intl.com).



## HENDRICKSON RECOMMENDED TORQUE VALUES Provided in foot pounds and in Newton Meters

### HENDRICKSON RECOMMENDED TORQUE SPECIFICATIONS

#### Drum Brakes



NO.	COMPONENT	FASTENER		*TORQUE VALUE	
		QUANTITY	SIZE	Foot Pounds	Newton Meters
1.	Torque Plate Hex Bolts to Knuckle	8	¾"	400 ± 50	542 ± 68
2.	Torque Plate Hex Nuts	6	¾"	400 ± 50	542 ± 68

**NOTE:** For fasteners not supplied by Hendrickson, follow the torque specification listed in the vehicle manufacturer's or the component manufacturer's service manual. Refer to the Parts List publication for your specific vehicle available online at [www.hendrickson-infl.com](http://www.hendrickson-infl.com).



# SECTION 11 Troubleshooting Guide

## STEERTEK NXT High Capacity for Fire and Rescue Vehicles

STEERTEK NXT TROUBLESHOOTING GUIDE		
CONDITION	POSSIBLE CAUSE	CORRECTION
Worn or damaged kingpins and kingpin bushings	Dirt in system– contaminated lubricant	Polish and inspect kingpin, replace bushing and seals, then follow specified lubrication procedures
	Incorrect lubricant	Lubricate axle with specified lubricant
	Axle not lubricated at scheduled frequency	Lubricant axle at scheduled frequency
	Incorrect lubrication procedures	Use correct lubrication procedures
	Lubrication interval not compatible with operating conditions	Change lubrication interval to match operating conditions
	Worn or missing seals	Replace worn or missing seals
Vibration or shimmy of front axle during operation	Caster out of specification	Adjust caster to specification
	Wheels and / or tires out of balance	Balance or replace wheels and / or tires
	Worn shock absorbers	Replace shock absorbers
	Wheel bearing adjustment	Check wheel bearing end play to the vehicle manufacturer’s specifications.
Excessive wear on tires or uneven tire tread wear	Tires have incorrect air pressure	Adjust tire pressure to manufacturer’s specification
	Tires out of balance	Balance or replace tires
	Incorrect axle alignment	Align axles
	Incorrect toe setting	Adjust toe-in to manufacturer’s specification
	Incorrect steering arm geometry	Repair steering system as necessary
	Excessive wheel bearing end play	Check specified wheel nut torque, replace worn or damaged wheel bearings
	Worn suspension components or kingpins	Replace components and / or kingpins
	Wheel bearing adjustment	Check wheel bearing end play to the vehicle manufacturer’s specifications
Vehicle is hard to steer	Low pressure in the power steering system	Repair power steering system
	Steering linkage needs lubrication	Lubricate steering linkage
	Steering knuckles are binding	Check vertical end play
	Incorrect steering arm geometry	Repair steering system as necessary
	Caster out of specification	Adjust caster to specification
	Tie rod ends hard to move	Replace tie rod ends
	Worn thrust bearing	Replace thrust bearing





## SECTION 12 Alignment Specifications

### STEERTEK NXT High Capacity for Fire and Rescue Vehicles

FRONT SUSPENSION ALIGNMENT SPECIFICATIONS			
CAMBER <sup>1</sup>	DESIGN SPECIFICATION	RANGE	
		MINIMUM	MAXIMUM
LEFT	0.0°±1.0°	-1.0°	+1.0°
RIGHT	-0.25°±1.0°	-1.25°	+0.75°
CROSS	0.0°	—	+2.0°
<b>CAMBER NOTES:</b>			
<ol style="list-style-type: none"> <li>The camber angle is not adjustable. <b>DO NOT</b> bend axle or otherwise try to adjust camber. If found out of specification, notify Hendrickson Tech Services for further information.</li> </ol>			
CASTER <sup>1,2</sup>	DESIGN SPECIFICATION	RANGE	
		MINIMUM	MAXIMUM
LEFT	3.75°±1.0°	+2.75°	+4.75°
RIGHT	3.75°±1.0°	+2.75°	+4.75°
CROSS <sup>3</sup>	0.0°	—	+1.5°
<b>CASTER NOTES:</b>			
<ol style="list-style-type: none"> <li>Caster is determined with the vehicle at specified ride height for air suspension or at rated load for mechanical suspension systems. It is critical that the vehicle front and rear ride height is within specifications prior to performing a caster measurement or adjustment. See Hendrickson ride height specifications and procedure.</li> <li>In most cases actual vehicle caster is defined with the frame rails at zero slope. Refer to the vehicle manufacturer's specifications for correct frame rail slope. (Both the alignment surface and the vehicle's frame rails should be level during execution of alignment procedures). For vehicles with a positive frame rake (higher in rear) add the frame slope (in degrees) to the caster reading to determine true vehicle caster.</li> <li><b>The Cross caster angle is not adjustable – DO NOT</b> bend axle or otherwise try to adjust cross caster. If found out of specifications notify Hendrickson Tech Services for further information. Changes to caster can be attained by using caster shims as provided by the vehicle manufacturer or chassis and body manufacturer. Caster shims must match, side to side, to reduce uneven loading to the suspension components. <b>The use of two (2) different angle caster shims will not correct cross caster.</b></li> <li><b>Example of caster adjustment:</b> 4.5° RH/5° Left Hand would require one (1), 1.0 shim on each side to increase caster and achieve 5.50° Right Hand/6.00° Left Hand, which is in specification. <b>DO NOT</b> attempt to use uneven shims.</li> </ol>			
<b>Hendrickson recommends the following TMC<sup>2</sup> practices:</b>			
TOTAL TOE <sup>2</sup>	DESIGN SPECIFICATION <sup>1</sup>	RANGE	
		MINIMUM	MAXIMUM
	1/16" ± 1/32" (0.06" ± 0.03")	1/32" (0.03")	3/32" (0.09")
<b>TOE-IN NOTES:</b>			
<ol style="list-style-type: none"> <li>Toe-in is to be set and adjusted in the normal vehicle unladed configuration. Actual vehicle curb weight on the ground. Toe should be checked at the tires front and rear tread center, at a distance above ground equal to the tire's rolling radius.</li> <li>In most instances total toe is set by the vehicle manufacturer or body builder. Consult the vehicle manufacturer for specifications.</li> </ol>			



## SECTION 13

# Reference Material

This technical publication covers Hendrickson Truck Suspension's recommended procedures for our parts / products. Other components play a major role in overall performance and Hendrickson recommends you follow the specific vehicle manufacturer's recommendation for care and maintenance. Some recommended procedures have been developed by The Technology & Maintenance Council (TMC) and Hendrickson supports these recommendations. We have compiled a list of these below.

### TMC

To obtain copies of the following RP's, video's, or charts, contact TMC at:

TMC/ATA  
2200 Mill Road  
Alexandria, VA 22314

Phone: 703-838-1763  
website: [tmc.truckline.com](http://tmc.truckline.com)  
online ordering: [www.truckline.com/store](http://www.truckline.com/store)

### Important References

TMC RP 214B	Tire/Wheel End Balance and Runout
TMC RP 216	Radial Tire Conditions Analysis Guide
TMC RP 219A	Radial Tire Wear Conditions and Causes
TMC RP 222A	User's Guide To Wheels and Rims
TMC RP 230	Tire Test Procedures for Tread wear, Serviceability, and Fuel Economy
TMC RP 514	Pre-Alignment Inspection
TMC RP 618	Wheel Bearing Adjustment Procedure
TMC RP 620B	Front End Alignment Steering Geometry
TMC RP 708A	Trailer Axle Alignment
TMC RP 642	Guidelines For Total Vehicle Alignment
TMC RP 644	Wheel End Conditions Analysis Guide
TMC RP 645	Tie Rod End Inspection and Maintenance Procedure

### Video's

TMC T0326	Wheel End Maintenance
TMC T0372	Tire Pre-Trip Inspection Guidelines

### Other

TMC T0400	Wheel bearing Adjustment Procedure Wall Chart
-----------	---



Actual product performance may vary depending upon vehicle configuration, operation, service and other factors.  
All applications must comply with applicable Hendrickson specifications and must be approved by the respective vehicle manufacturer with the vehicle in its original, as-built configuration.  
Contact Hendrickson for additional details regarding specifications, applications, capacities, and operation, service and maintenance instructions.

*Call Hendrickson at **1.866.755.5968** (toll-free) or **1.630.910.2800** for additional information.*



[www.hendrickson-intl.com](http://www.hendrickson-intl.com)

**TRUCK COMMERCIAL VEHICLE SYSTEMS**  
800 South Frontage Road  
Woodridge, IL 60517-4904 USA  
1.866.755.5968 (Toll-free U.S. and Canada)  
1.630.910.2800 (Outside U.S. and Canada)  
Fax 1.630.910.2899

17730-311 Rev B 04-19

© 2018 – 2019 Hendrickson USA, L.L.C. All Rights Reserved. All trademarks shown are owned by Hendrickson USA, L.L.C., or one of the affiliates, in one or more countries.  
Information contained in this literature was accurate at the time of publication. Product changes may have been made after the copyright date that are not reflected.

Printed in United States of America