

H PARTS LIST

HAULMAAX® 40K • 46K Rear Suspension

LIT NO: SP-171

DATE: August 2019

REVISION: L

CONTENTS

DESCRIPTION	PAGE	DESCRIPTION	PAGE
Parts List – HAULMAAX 40K • 46K	2	Aftermarket Service Kits	
Notes	4	■ Aftermarket Dual Rebound Strap Enhancement Kit for Outrigger Applications	7
Selection Guides		■ Aftermarket Shock Absorber Service Kits	7
■ Outboard Frame Bracket	5	Special Tools	8
■ Inboard Frame Bracket	5		
Production Dual Rebound Straps – Outrigger Applications	6		

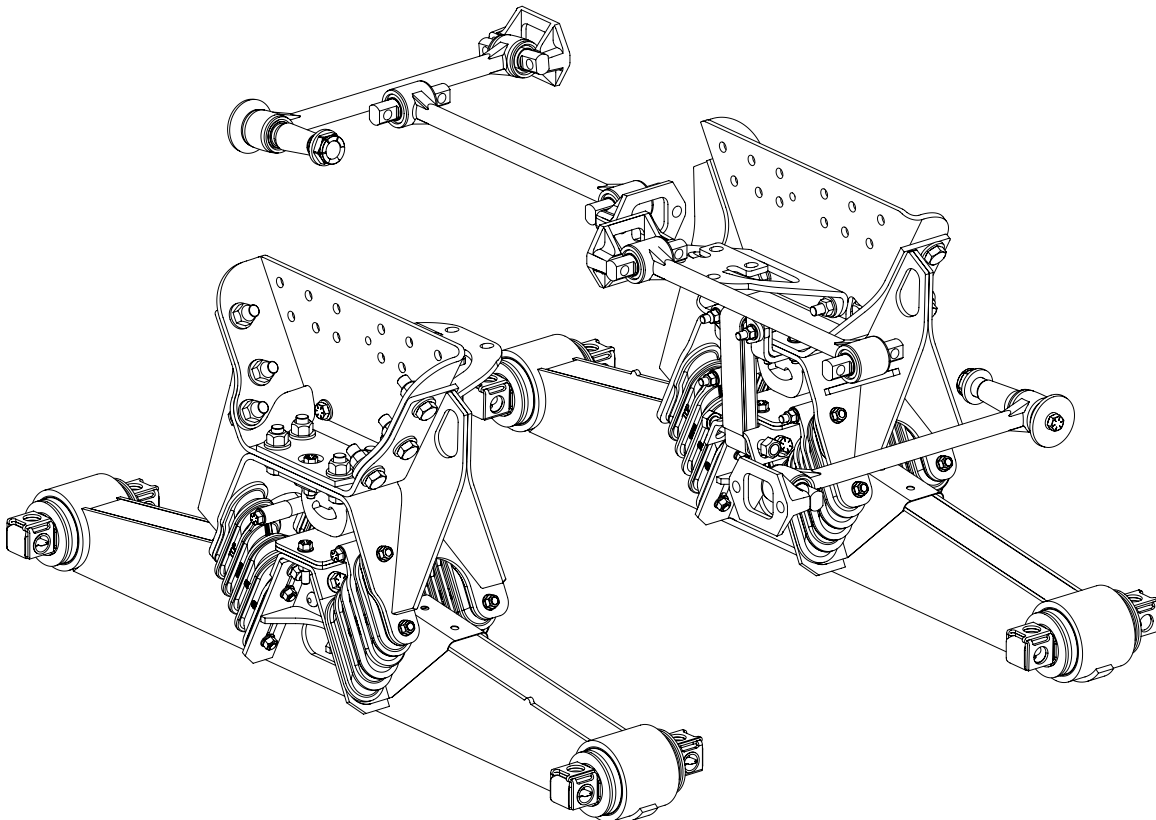

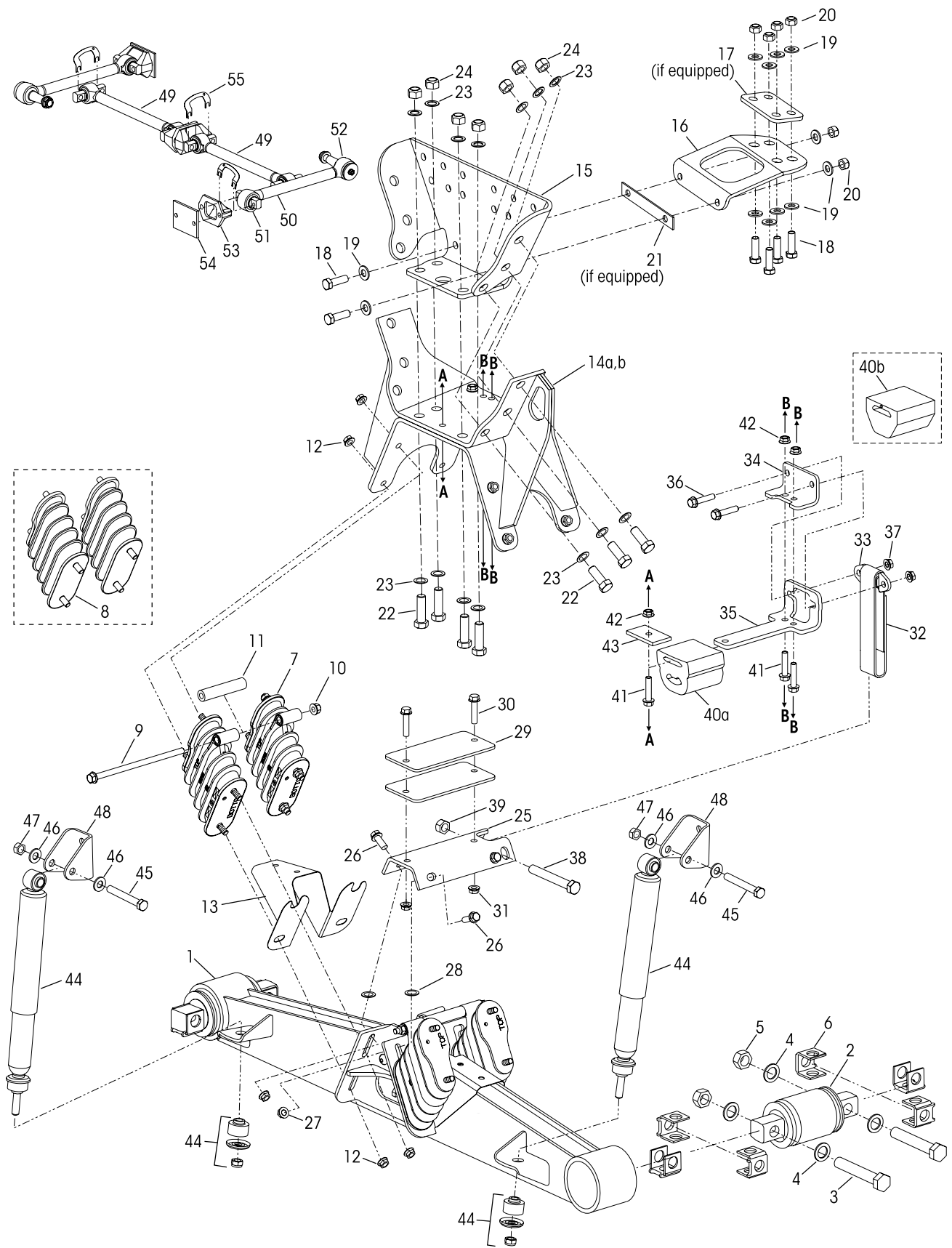



KEY NO.	PART NO.	DESCRIPTION	VEHICLE QTY.
1		****Equalizing Beam Assembly, 40K • 46K	2
	64846-003	52", with Shock Bracket	
	64847-003	52", without Shock Bracket	
	64846-001	54", with Shock Bracket	
	64847-001	54", without Shock Bracket	
	64846-002	60", with Shock Bracket	
	64847-002	60", without Shock Bracket	
		****Equalizing Beam Assembly, 40K • 46K, with dual straps	
	64846-006	52", with Shock Bracket	
	64847-006	52", without Shock Bracket	
	64846-004	54", with Shock Bracket	
	64847-004	54", without Shock Bracket	
	64846-005	60", with Shock Bracket	
	64847-005	60", without Shock Bracket	
		Bar Pin End Bushing Service Kit, One Wheel End, Includes Key Nos. 2-6a	
	34013-088L	Shim Type	
	34013-188L	Rotating, Shim Type	
2		*Bar Pin Bushing	4
	34013-104	Bar Pin End Bushing Fastener Kit, One Wheel End, Includes Key Nos. 3-5	
3		*1"-8 UNC x 6" Hex Bolt	8
4		*1" Hardened Washer	16
5		*1"-8 UNC Locknut	8
6		Bar Pin Shim	8
	a 50131-000	0.25"/0.12" Standard	
	b 50130-000	0.19"/0.19" Optional	
	c 57026-000	0.375" Optional flat shim	
	60961-712	Tie-bar Bolster Springs and Progressive Load Spring Service Kit, One Side, Includes two 64179-048 and one 60961-745 Service Kits	
	64179-048	** Tie-bar Bolster Spring Service Kit, 2 Bolsters with 1 Wear Plate, Includes Key Nos. 7, 9-13	
	64179-049	** Bolster Spring Service Kit, 2 Bolsters with 1 Wear Plate, Includes Key Nos. 8, 12-13	
7		*Tie-bar Bolster Spring	8
8		*Bolster Spring	8
9	60818-003	½"-13 UNC x 10" Flange Bolt for Tie-bar	4
10	60819-000	½"-13 UNC Flange Nut for Tie-bar	4
11	65742-000	Tie-bar Bolster Spring Spacer	4
12	60819-000	½"-13 UNC Flange Nut	32
13	64890-000L	Wear Plate, <i>Replaces 60498-001 and 60498-002</i>	4
		Saddle Assembly Service Kit, Tandem Set, HAULMAAX 40K, Includes Key No. 14a and Kit No. 57974-048	
	57974-051		
	57974-050	HAULMAAX 46K, Includes Key No. 14b and Kit No. 57974-049	
		Saddle Assembly Fastener Kit, Tandem Set, HAULMAAX 40K, Includes Key Nos. 12, 22-24, 26-27, 36-37, 41-42	
	57974-048		
	57974-049	HAULMAAX 46K, Includes Key Nos. 9-12, 22-24, 26-27, 36-37, 41-42	
14		***Saddle Assembly, Vehicles built after 01/13/03	2
	a 64642-000	HAULMAAX 40K	
	b 64643-000	HAULMAAX 46K	
15		***Outboard Frame Bracket, <i>see Page 5</i> Vehicles built after 01/12/03	2
16		Inboard Frame Bracket, <i>see Page 5</i>	2
17	78441-000	Inboard Frame Bracket Shim, (46K, <i>if equipped,</i> <i>International Truck Only</i>)	2
18	32043-004	⅝"-11 UNC x 2¼" Hex Bolt *****M16 Hex Bolt	12
19	22962-004	⅝" Hardened Washer *****M16 Hardened Washer	24
20	47764-000	⅝"-11 UNC Locknut *****M16 Locknut	12

KEY NO.	PART NO.	DESCRIPTION	VEHICLE QTY.
21		Inboard Spacer (<i>if equipped</i>)	As Req.
	60618-001	⅛" Thick	
	60618-002	⅜" Thick	
		Outboard Frame Bracket to Saddle Assembly Fastener Kit, Includes Key Nos. 22-24	
	64179-038	Tandem Set	
	64179-039	One Side	
22		*M20 x 2.5-6G x 65 mm Hex Bolt	20
23		*M20 Hardened Washer	40
24		*M20 x 2½-6H Locknut	20
	57974-046	Contact Plate Service Kit, One Side, Includes Key Nos. 25-27	
25	59191-000	Load Spring Contact Plate	2
26		*⅝"-11 UNC x 1½" Flange Bolt for Vehicles built after 11/07 **** <i>Replaces 60818-001</i>	8
27		*⅝"-11 UNC Flange Nut for Vehicles built after 11/07 **** <i>Replaces 60819-000</i>	8
28		****Load Spring Contact Plate Spacer for Vehicles built prior to 11/07	8
29	60791-000	Load Spring Shim ¼" Thickness Quantity may vary for vehicles built prior to 07/15/14 equipped with Auxiliary Load Spring	4
30	60818-002	½"-13 UNC x 2¼" Flange Bolt	4
31	60819-000	½"-13 UNC Flange Nut	4
	64179-028	Rebound Strap Service Kit, One Side, Includes Key Nos. 32-33, 36-39	
32		*Rebound Strap	2
33		*Rebound Clip	2
34	60613-000	Rebound Support Angle	2
35	59384-000	Load Spring Bracket	2
36	60818-002	½"-13 UNC x 2¼" Flange Bolt	4
37	60819-000	½"-13 UNC Flange Nut	4
38	21867-007	¾"-16 UNF x 6" Hex Bolt	2
39	30191-000	¾"-16 UNF Locknut	2
		Progressive Load Spring Service Kits for vehicles built after 07/15/14	
	60961-745	One Side, Includes Key Nos. 40a, 41-42	
	60961-747	Tandem Set, Includes Key Nos. 40a, 41-42 • Also use as a conversion kit for vehicles built prior to 07/15/14	
	60961-746	Weight Bias Kit with Shims, Includes Key Nos. 29-31, 40a,b, 41-42, <i>Replaces 65902-004</i>	
	64179-004	Auxiliary Load Spring Service Kit, One Side, for vehicles built prior to 07/15/14 Includes Key Nos. 40b, 41-42	
40		Load Spring	2
	a	*Progressive	
	b	*Auxiliary	
41		*⅜"-13 UNC x 2¼" Flange Bolt	6
42		*⅜"-13 UNC Flange Nut	6
43	60874-000	Load Spring Spacer	2
		Single Shock Absorber Service Kit, (<i>if equipped</i>) Includes Key Nos. 44-47	
	64178-005	16½" Saddle Height	
	64178-006	17½" / 18½" Saddle Height	
		Aftermarket Shock Absorber Kit, for vehicles built with equalizing beams without welded shock absorber mounts, <i>see Page 7</i>	
44		Shock Absorber Assembly (<i>if equipped</i>)	4
	60680-004L	16½" Saddle Height (<i>see Figure 2</i>)	
	60680-005L	17½" / 18½" Saddle Height (<i>see Figure 2</i>)	
45	32043-005	⅝"-11 UNC x 4½" Hex Bolt (<i>if equipped</i>)	4
46	22962-004	⅝" Hardened Washer (<i>if equipped</i>)	8
47	47764-000	⅝"-11 UNC Locknut (<i>if equipped</i>)	4
48	60304-000	Upper Shock Bracket (<i>if equipped</i>)	4



KEY NO.	PART NO.	DESCRIPTION	VEHICLE QTY.
49		One-piece Longitudinal Torque Rod Assembly, Straddle/Straddle, Specify Length in mm ULTRA ROD®, Includes Key No. 51	
	62000-XXX	Front	1
	62001-XXX	Rear	1
	8240-00XX-XXX	*****TRAAX ROD™, Replaces 72000-XXX and 72001-XXX	2
50		*****One-piece Transverse Torque Rod Assembly, 2 Straddle/Taper, Specify Length in mm	2
	62350-XXX	ULTRA ROD, Includes Key Nos. 51-52	
	8244-0099-XXX	*****TRAAX ROD, Replaces 72350-XXX	
	8233-0099-XXX	*****TRAAX ROD, Replaces 92350-XXX	
51	47691-000L	Straddle Bushing	6

KEY NO.	PART NO.	DESCRIPTION	VEHICLE QTY.
52	64697-000L	Taper Bushing	2
		Optional Two-Piece Torque Rod Assembly with Bushings Service Kit	
	60218-000	ULTRA ROD Straddle/Straddle	
	60215-000	ULTRA ROD Straddle/Taper	
	65781-000	ULTRA ROD PLUS Straddle/Taper	
	65781-001	XTRB Straddle/Straddle	
	65781-002	XTRB Straddle/Taper	
53	22186-000	Torque Rod Frame Bracket	2
54	45045-003	Back-up Plate (for Torque Rod)	2
55	49689-000L	Torque Rod Shim	As Req.
	70867-001	P-80 Lubricant - 10 ml (Not Shown)	per Bushing 1

Figure 1

Outboard Frame Bracket Top View

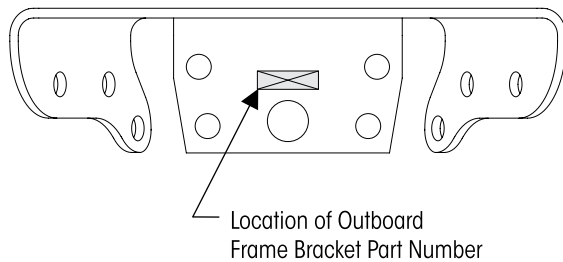
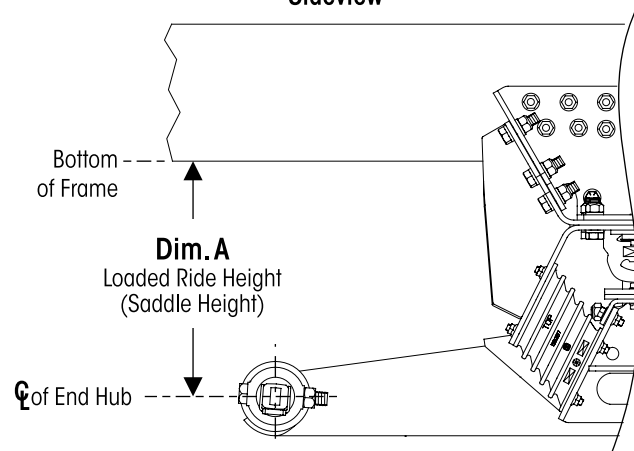

Figure 2

Sideview



NOTES:

- * Item included in kit / assembly only, part not sold separately.
- ** HAULMAAX 46K suspensions must be serviced with the new tie-bar bolster spring Kit No. 64179-048. All HAULMAAX 40K suspensions can be serviced using the existing bolster springs Kit No. 64179-049 or if preferred, tie-bar bolster spring Kit No. 64179-048. Refer to Hendrickson Technical Bulletin Literature No. SEU-0225 for more information.
- *** For vehicles built prior to January 2003 it will be necessary to replace the saddle assembly with the current production saddle assembly and corresponding outboard frame bracket.
- **** For vehicles built prior to November 2007, Kit No. 57974-046 is required when replacing the load spring contact plate or equalizing beam.
- ***** Transverse torque rods are mandatory for the HAULMAAX suspensions regardless of axle spacing, see Literature No. 59310-004 and 59310-058 for more information.
- ***** Not supplied by Hendrickson, used for reference only. Refer to vehicle manufacturer for more information. Hendrickson is not responsible for components supplied by vehicle manufacturer.
- ***** Longitudinal and transverse TRAAX ROD bushings are non-serviceable, the entire torque rod assembly requires replacement. Visit TRAAX ROD website www.traaxrods.com for more information.

Hendrickson HAULMAAX / HN Gauge can be obtained on-line at www.hendrickson-intl.com/Litform

- Literature number 48422-546 – Bolster Spring
- Literature number 48422-590 – Progressive Load Spring

To obtain a new Hendrickson HAULMAAX Decal, No. 60905-002, contact Hendrickson.



■ Outboard • Inboard Frame Bracket Selection Guides

Key No. 15		Outboard Frame Bracket — Vehicles built after 01/13/03					
Vehicle Manufacturer	Frame Width	Saddle Height = Dim. A in Figure 2					
		16½"	17½"	18½"	20¼"	22½"	25½"
Autocar	34"	64595-611	64595-612	64595-613			
CCC		64595-801 <i>replaces 64595-001</i>					
Freightliner	34.3" - 34.5"	64636-001	64636-002	64636-003			
GM	34.75"		64595-701				
International Truck	34.12" - 34.25"	64595-101			64595-105	64595-107	
	34.68" - 34.94"	64595-104		64595-114	64595-106	64595-108	64595-110
Mack	33.5"	64595-301	64595-302	64595-303			
	34.3"		64595-307				
Oshkosh	34"			64595-003			
Paccar		64595-001	64595-002	64595-003	64595-105		
	34.75"	64595-004	64595-005	64595-006			
Volvo	33.5"	64595-301					
Western Star	34"	64595-001	64595-002	64595-003			

Key No. 16			Inboard Frame Bracket					
Vehicle Manufacturer	Frame Width	Equalizing Beam Length	Saddle Height = Dim. A in Figure 2					
			16½"	17½"	18½"	20¼"	22½"	25½"
Autocar	34"	All	60617-601	60617-602	60617-603			
CCC			65078-001	65078-002	65078-003			
Freightliner	34.3" - 34.5"		60617-501	60617-502	60617-503			
GM	34.75"			60617-701				
International Truck	34.12" - 34.25"		60617-101		60617-104	60617-103		69681-000
	34.68" - 34.94"			60617-201				
International Truck with shim	34.5"				65078-003			
Oshkosh	34"							
Paccar with liner	34", 34.75"		67545-001 <i>replaces 65078-001</i>	67545-002 <i>replaces 65078-002</i>	67545-003 <i>replaces 65078-003</i>			
Paccar without liner	34", 34.75"		65079-001	65079-002	65079-003			
Western Star	34"	60617-501	60617-502	60617-503				
Mack	33.5", 34.3"	52", 60"	64988-311					
		54"	64988-301					
Volvo	33.5"	54"	64988-302					
		52", 60", 72.5"	64988-312					



■ Production Dual Rebound Straps – Outrigger Applications

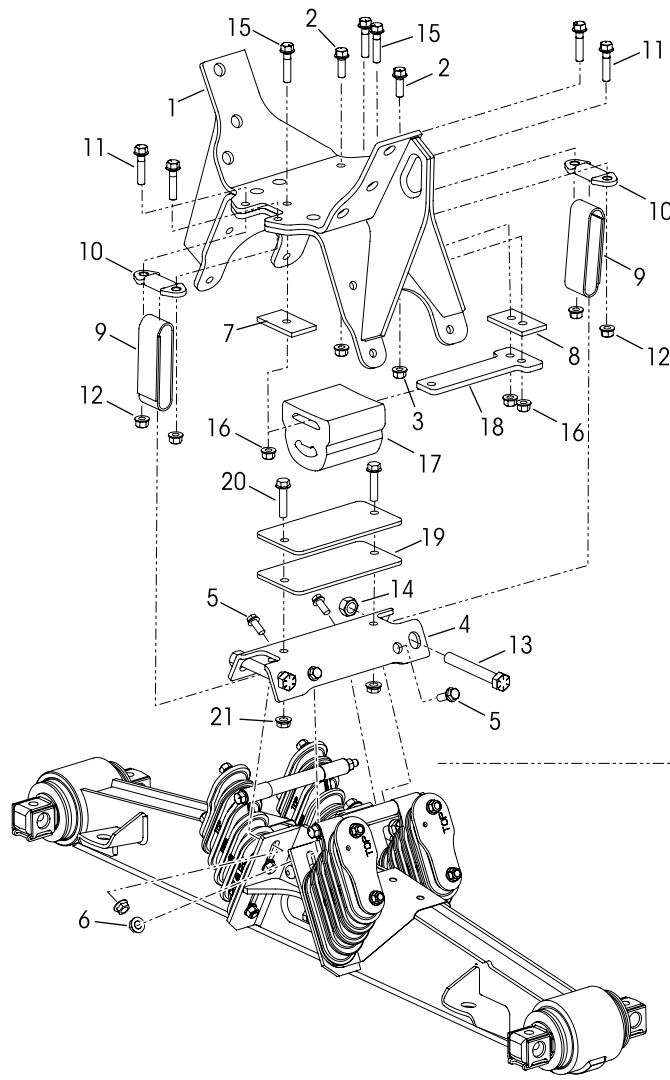

- Refer to Pages 2 and 3 for equalizing beam part information.
- Refer to Page 5 for Outboard • Inboard Frame Bracket Selection Guides.

KEY NO.	PART NO.	DESCRIPTION	VEHICLE QTY.
		Saddle Assembly Service Kits, One Side,	
	34013-335	HAULMAAX 40K, Includes Key No. 1 and Kit No. 34013-336	
	34013-337	HAULMAAX 46K, Includes Key No. 1 and Kit No. 34013-338	
		Saddle Assembly Fastener Kits, One Side,	
	34013-336	HAULMAAX 40K, Includes Key Nos. 5-6, 11-12, 15-16 (Refer to Page 3 for more information on Key Nos. 12, 22-24)	
	34013-338	HAULMAAX 46K, Includes Key Nos. 5-6, 11-12, 15-16 (Refer to Page 3 for more information on Key Nos. 9-12, 22-24)	
1	79564-000	Saddle Assembly, Vehicles built with Dual Rebound Straps	2
2	60818-001	½"-13 UNC x 1½" Flange Bolt	4
3	60818-002	½"-13 UNC Flange Nut	4
	34013-339	Contact Plate Service Kit, One Side, Includes Key Nos 4-6	
4	59191-004	Load Spring Contact Plate	2
5	67290-001	⅝"-11 UNC x 1½" Flange Bolt	8
6	67291-000	⅝"-11 UNC Flange Nut	8

KEY NO.	PART NO.	DESCRIPTION	VEHICLE QTY.
7	60874-000	3⅜" Load Spring Spacer	2
8	60874-001	3¾" Load Spring Spacer	2
	34013-340	Rebound Strap Service Kit, One Side, Includes Key Nos. 9-14	
9		*Rebound Strap	4
10		*Rebound Clip	4
11	60818-002	½"-13 UNC x 2¼" Flange Bolt	8
12	60819-000	½"-13 UNC Flange Nut	8
13	21867-026	¾"-16 UNF x 5½" Bolt	4
14	30191-000	¾"-16 UNF Locknut	4
	34013-341	Progressive Load Spring Service Kit, One Side, Includes Key Nos. 15-17	
15	60818-002	½"-13 UNC x 2¼" Flange Bolt	6
16	60819-000	½"-13 UNC Flange Nut	6
17		*Progressive Load Spring	2
18	59384-005	Load Spring Bracket	2
19	60791-000	Load Spring Shim ¼" Thickness	4
20	60818-002	½"-13 UNC x 2¼" Flange Bolt	4
21	60819-000	½"-13 UNC Flange Nut	4



■ Aftermarket Service Kits

AFTERMARKET DUAL REBOUND STRAP ENHANCEMENT KIT FOR OUTRIGGER APPLICATIONS

Service Kit No.
64179-046 with Bolster Springs Tandem Set
64179-045 Tandem Set

Reference Lit. No. 59310-048

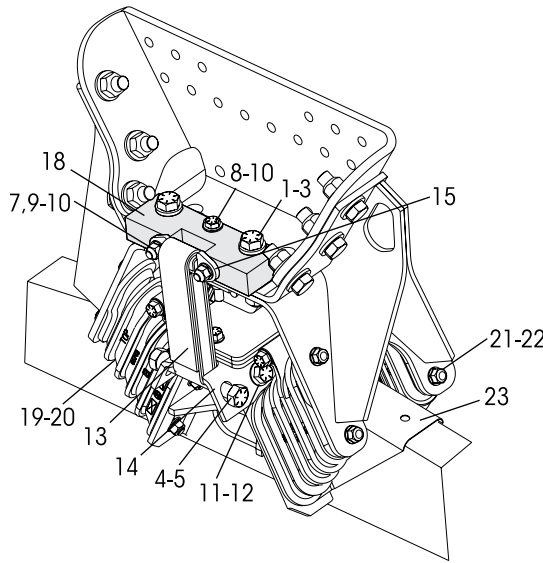

KEY NO.	PART NO.	DESCRIPTION	KIT QTY.
	64179-046	Aftermarket Dual Rebound Strap Enhancement with Bolster Springs, Tandem Set, Includes Key Nos. 1-23	
	64179-045	Aftermarket Dual Rebound Strap Enhancement Tandem Set, Includes Key Nos. 1-18	
1	21867-007	3/4"-16 UNF x 6" Bolt	4
2	30191-000	3/4"-16 UNF Locknut	4
3	22962-001	3/4" Hardened Washer	4
4	50764-016	3/4"-10 UNC x 4" Bolt	4
5	66137-000	3/4"-10 UNC Flange Locknut	4
6	60818-002	1/2"-13 UNC x 2 1/4" Flange Bolt (Not Shown)	4
7	24531-009	1/2"-13 UNC x 4" Bolt	12
8	24531-014	1/2"-13 UNC x 5" Bolt	2
9	60819-000	1/2"-13 UNC Flange Nut	18
10	22962-011	1/2" Hardened Washer	14
11	67290-001	5/8"-11 UNC x 1 1/2" Flange Bolt	8
12	67291-000	5/8"-11 UNC Flange Nut	8
13	57878-017	Rebound Strap	4
14	59191-002	Load Spring Contact Plate	2
15	60612-000	Rebound Clip	2
16	60874-001	Load Spring Spacer (Not Shown)	2
17	68851-001	Inboard Rebound Support Block (Not Shown)	2
18	69026-000	Outboard Rebound Support Block	2
19		*Tie-bar Bolster Spring	4
20	65742-000	Bolster Spring Spacer	4
21	60818-003	1/2"-13 UNC x 10" Flange Bolt	4
22	60819-000	1/2"-13 UNC Flange Nut	36
23	64890-000	Wear Plate	4

AFTERMARKET SHOCK ABSORBER SERVICE KITS

Service Kit Nos. Saddle Ht. For equalizing beams not equipped with lower shock mount

64178-003 16 1/2"

64178-004 17 1/2" / 18 1/2"

64178-009 16 1/2" (Mack)

Reference Lit. No. 59310-012

NOTE:
 Not available with 315 mm tires

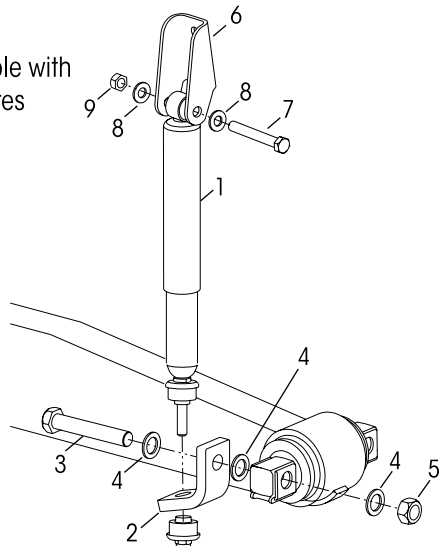

KEY NO.	PART NO.	DESCRIPTION	KIT QTY.
	64178-003	Shock Absorber Service Kit, Tandem Set 16 1/2" Saddle Height, Includes Key Nos. 1a, 2a-b, 3-9	
	64178-004	17 1/2"/18 1/2" Saddle Height, Includes Key Nos. 1b, 2a-b, 3-9	
	64178-009	16 1/2" Saddle Height - Mack Only, Includes Key Nos. 1c, 2c, 3-9	
1		Shock Absorber Assembly	4
a	60680-004L	16 1/2" Saddle Height	
b	60680-005L	17 1/2"/18 1/2" Saddle Height	
c	60680-006L	16 1/2" Saddle Height - Mack	
2		Lower Shock Bracket	
a	64148-001	Front	2
b	64148-002	Rear (Not Shown)	2
c	64835-000	Mack Only, Front and Rear (Not Shown)	4
3	48941-006	1"-8 UNC x 7" Hex Bolt, <i>Replaces 48941-001</i>	4
4	22962-008	1" Hardened Washer	12
5	48942-000	1"-8 UNC Locknut	4
6	64146-000	Upper Shock Bracket	4
7	32043-005	5/8"-11 UNC x 4 1/2" Hex Bolt	4
8	22962-004	5/8" Hardened Washer	8
9	47764-000	5/8"-11 UNC Locknut	4

■ Special Tools

BAR PIN END BUSHING TOOLS

INSTALLATION TOOLS

Hendrickson Part No. **66086-103**
 OTC Part No. **1757** Visit otctools.com



Special tooling is required to service the bar pin end bushings. Hendrickson part number 66086-103 tool is used with the equalizing beam removed from the truck, and in conjunction with OTC No. 51100 press plate and a 100-ton hydraulic shop press.

REMOVAL TOOLS

Hendrickson Part No. **66086-104**
 OTC Part No. **206457** Visit otctools.com



Hendrickson Part No. **66086-105**
 OTC Part No. **302030** Visit otctools.com



TORQUE ROD FUNNEL TOOLS

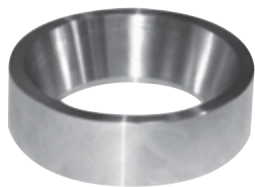

ULTRA ROD
 Hendrickson Part No. **66086-001L**

ULTRA ROD PLUS
 Hendrickson Part No. **66086-000L**

This is a general parts list to provide directional information. Components may vary by model. Questions in regards to parts, contact Hendrickson Truck Parts at 1.866.755.5968 (Toll-free U.S. and Canada), 630.910.2800 (Outside U.S. and Canada) or e-mail: truckparts@hendrickson-intl.com.

Actual product performance may vary depending upon vehicle configuration, operation, service and other factors. All applications must comply with applicable Hendrickson specifications and must be approved by the respective vehicle manufacturer with the vehicle in its original, as-built configuration. Contact Hendrickson for additional details regarding specifications, applications, capacities, and operation, service and maintenance instructions.

Call Hendrickson at 1.866.755.5968 (toll-free) or 1.630.910.2800 for additional information.



www.hendrickson-intl.com

SP-171 Rev L 08-19

© 2002-2019 Hendrickson USA, L.L.C. All Rights Reserved. All trademarks shown are owned by Hendrickson USA, L.L.C., or one of the affiliates, in one or more countries.

Information contained in this literature was accurate at the time of publication. Product changes may have been made after the copyright date that are not reflected.

TRUCK COMMERCIAL VEHICLE SYSTEMS
 800 South Frontage Road
 Woodridge, IL 60517-4904 USA
 1.866.755.5968 (Toll-free U.S. and Canada)
 1.630.910.2800 (Outside U.S. and Canada)
 Fax 1.630.910.2899

Printed in United States of America