

H TECHNICAL PROCEDURE

INTRAAX® / VANTRAAX® CAM TUBE

SUBJECT: Cam Tube Kit Installation

LIT NO: L762

DATE: November 2014

REVISION: D

CAM TUBE KIT INSTALLATION ON INTRAAX® OR VANTRAAX® SUSPENSIONS

The cam tube service kit can be installed on MOST INTRAAX / VANTRAAX suspensions equipped with drum brakes and cam tube from the inboard side of the wheel. It is not necessary to remove the hub, tire/wheel assembly or brake drum.

Refer to Hendrickson publication *L974 Drum Brake Maintenance Procedures* (available at www.hendrickson-intl.com) for complete brake adjuster and S-cam tube removal and safety instructions.

IMPORTANT: Do not weld or otherwise fasten the cam tube assembly to the spider. The cam tube assembly simply "slip fits" into the spider.

INSTALLING CAM TUBE COMPONENTS

1. If necessary, remove the brake adjuster from the camshaft and remove the existing cam tube.

IMPORTANT: If included, replace original parts with new parts included in the kit.

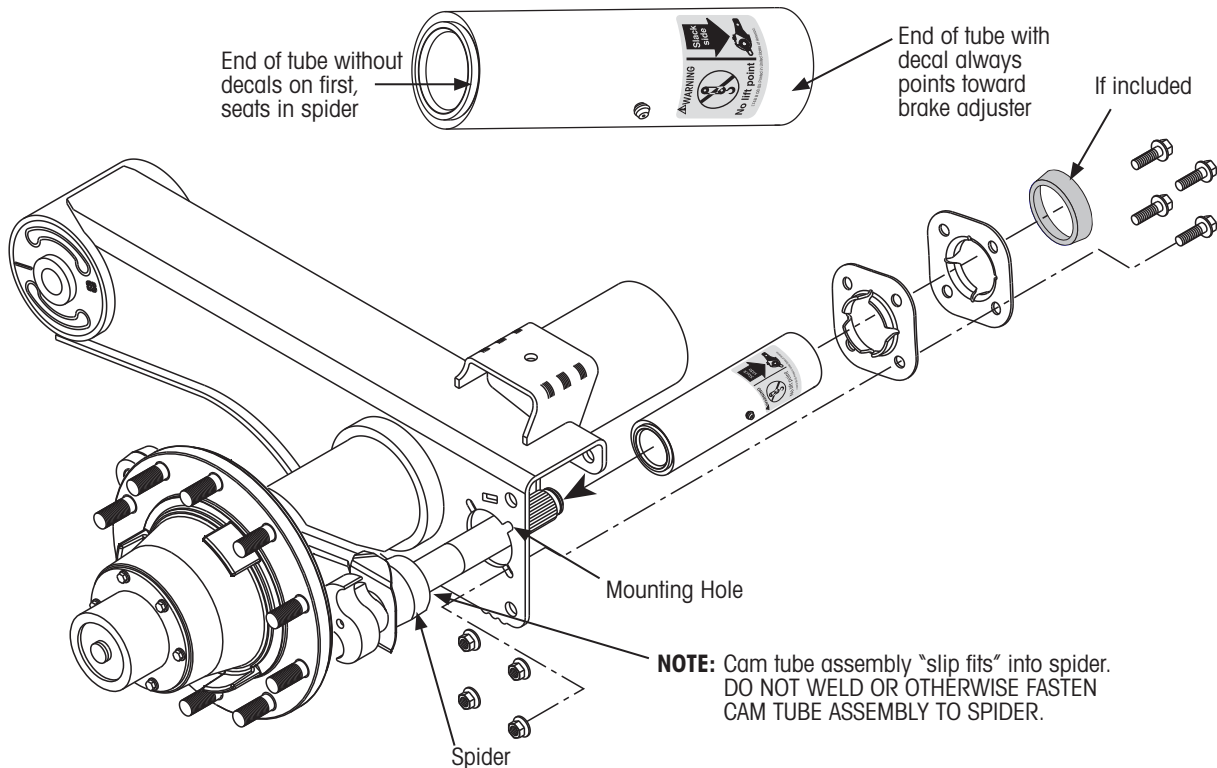

Figure 1: Cam tube assembly installation overview

2. Using #2EP NLGI chassis lube, lightly lubricate the internal seals and bushings on both ends of the new cam tube assembly.
3. Orient the end of the cam tube without the decal so that it goes onto the camshaft first (Figure 1). In other words, the end of the cam tube with the decal must be closest to the slack adjuster.
4. From the inboard side of the suspension beam, slide the new cam tube assembly onto the camshaft, through the mounting hole in the suspension beam and into the spider (Figure 1).
5. Rotate the cam tube so the grease fitting is pointing rearward and accessible when the drums are installed.

NOTICE: Pointing the grease fitting downward exposes it to road debris that can damage the fitting.

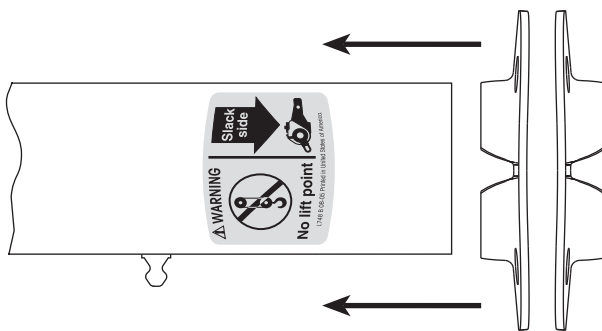

Figure 2: Install brackets back to back on cam tube

6. Arrange the two Cam tube support brackets (item 4) back-to-back and slide them onto the end of the cam tube assembly (Figure 2). Slide the brackets onto the cam tube until they contact the suspension beam.
7. Rotate the Cam tube support brackets so their holes align with the holes (or slots) in the suspension beam. If necessary, rotate the cam tube so the grease fitting is accessible and pointing to the rear when the drums are installed.
8. Install the four nuts and bolts (Figure 3). Tighten to 40 ±5 ft. lbs. (55 ±6 N•m) of torque.
9. Slide the "S-cam journal washer" (item 6, Figure 3) onto the camshaft and seat it against the cam tube assembly.

NOTE: Always use new inner cam washers and retaining rings that come with the kit.

10. Using retaining ring pliers, hold open the "Retaining ring" (item 7, Figure 3) and slide it on the end of the camshaft. Lock the "Retaining ring" into "Retaining ring" groove on the camshaft.
11. (IF INCLUDED)
Snap rubber cam tube boot (item 5, Figure 3) over and behind "S-cam journal washer" (item 6, Figure 3) installed in step 9. Refer to Figure 4 assembly for proper placement.

INSTALLING "SLACK ADJUSTER"

1. Slide the second "S-cam journal washer" (item 6, Figure 3) onto the camshaft and seat it against the "Retaining ring" (item 7, Figure 3).

NOTE: 3 "Spline inner washers" are included with the kit. Not all may be required for steps 2 and 3.

2. Slide "Slack adjuster" (item 10) over the spline gear according to manufacturer's instructions. Adjust number of spline inner washers as needed from step 2.
3. Install enough "Spline inner washers" (item 8) to leave room for the "Spline retaining ring" (item 9) to fit in the retaining ring groove and align "Slack adjuster" (item 10) with Brake Chamber push rod and clevis (item 11). Refer to Figure 3.

A "Spline inner washer" (item 8). may be required before the slack adjuster.
4. Complete the installation by placing the "Spline retaining ring" (item 9) in the groove provided at the end of the S-cam.

LUBRICATION

Lubricate the single, centrally located grease fitting with #2EP NLGI chassis lube. Add grease until fresh grease can be seen purging from the inboard end of the cam tube or from the boot (if included) at point "B" shown in Figure 4. Wipe away excess grease purged from joints. This will help prevent contaminants from being attracted to the lube points, if the trailer is equipped with a chassis auto lube system, correct lube should be applied and equipment calibrated for application. Hendrickson recommends a manual hand grease gun to be used, and not a pneumatic shop tool.

NOTE: Initial fill on a new installation may require many pumps of lube to completely fill cam tube and ensure best service life.

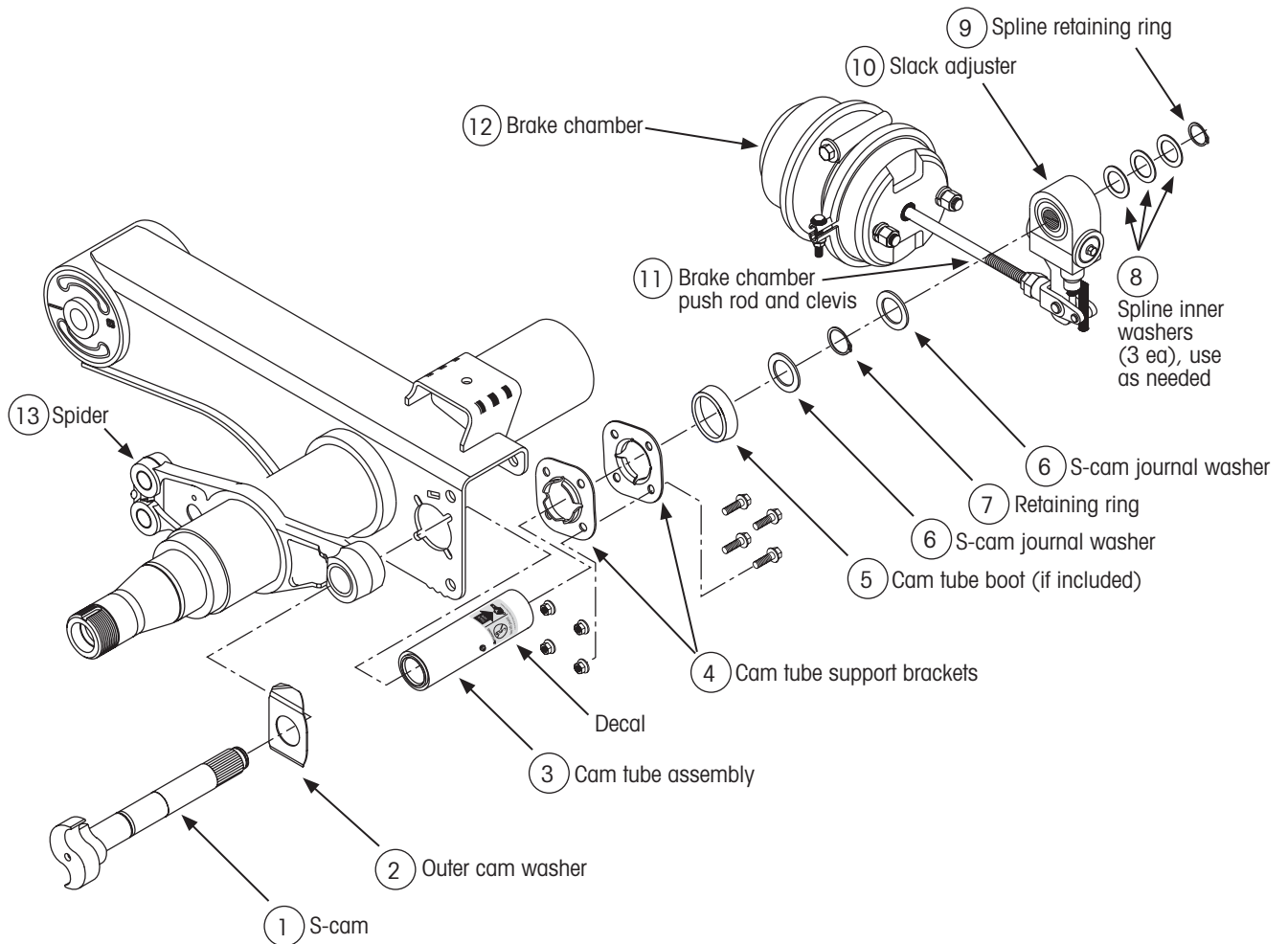
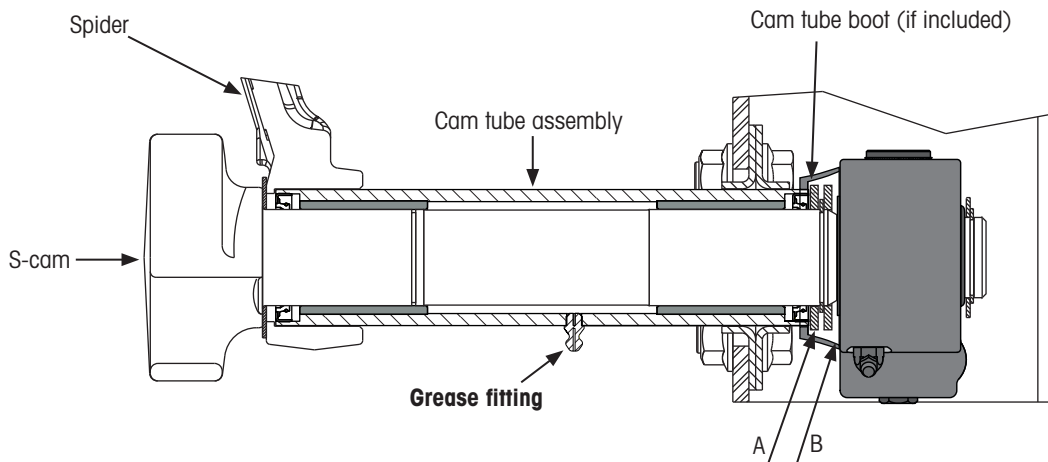

Figure 3: Cam Tube System parts identification (refer to L1104 for part numbers)



NOTE: Add grease until it exits at end of cam tube at point A, or at point B, if boot is included.

Apply grease until fresh grease is visible. Wipe away excess grease.

Figure 4: Accessible grease fitting orientation (top cross-section view)

Call your trailer dealer or Hendrickson at **866.RIDEAIR (743.3247)** for additional information.



www.hendrickson-intl.com

TRAILER COMMERCIAL VEHICLE SYSTEMS

2070 Industrial Place SE
Canton, OH 44707-2641 USA
866.RIDEAIR (743.3247)
330.489.0045 • Fax 800.696.4416

Hendrickson Canada

250 Chrysler Drive, Unit #3
Brampton, ON Canada L6S 6B6
800.668.5360
905.789.1030 • Fax 905.789.1033

Hendrickson Mexicana

Circuito El Marqués Sur #29
Parque Industrial El Marqués
Pob. El Colorado, Municipio El Marqués,
Querétaro, México C.P. 76246
+52 (442) 296.3600 • Fax +52 (442) 296.3601