

H TECHNICAL PROCEDURE

TRAILER SUSPENSION SYSTEMS HXL3® WHEEL END SYSTEM

SUBJECT: Hub Maintenance Procedures

LIT NO: T72006

DATE: April 2020

REVISION: B

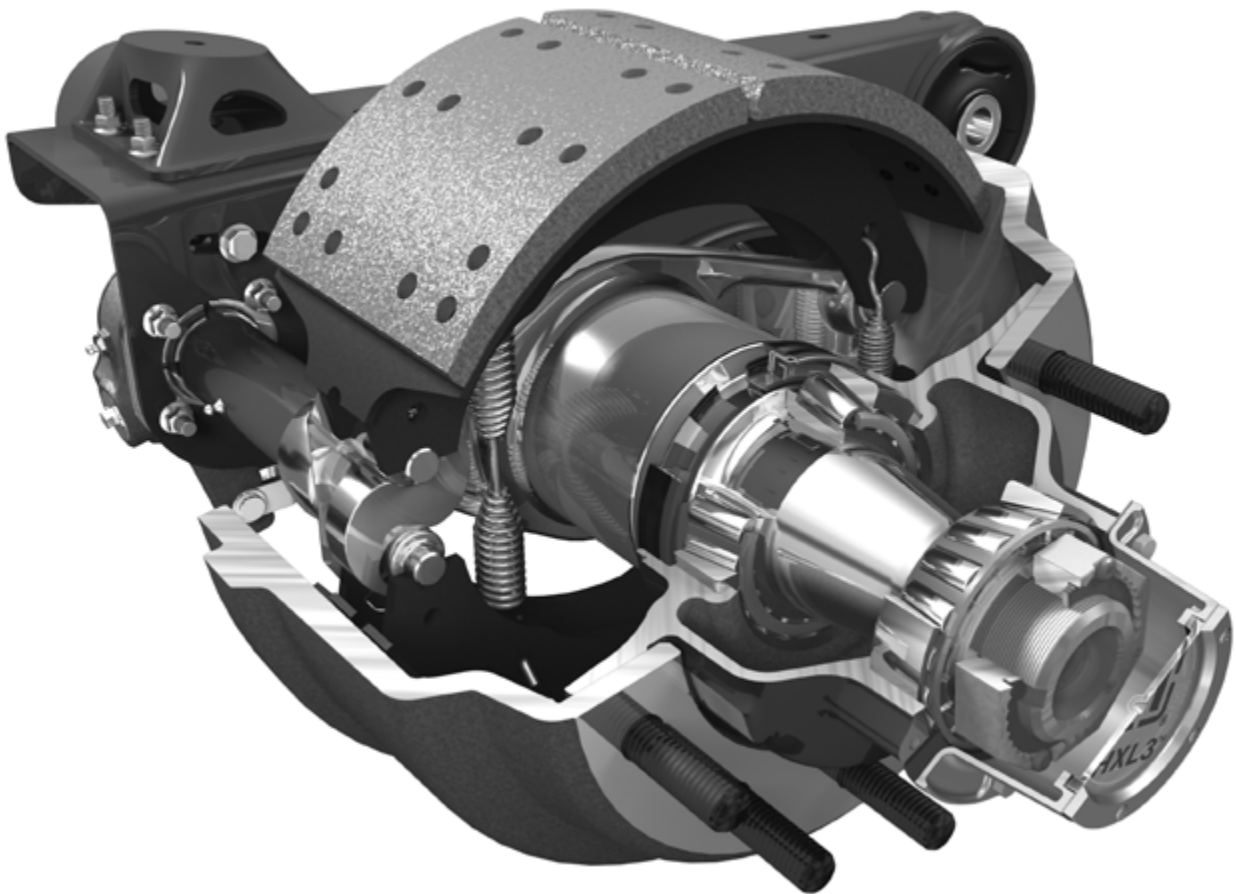



TABLE OF CONTENTS

Important Safety Notices **3**

Conventions Applied in This Document **3**

 Explanation of Signal Words 3

 Hyperlinks 3

 Contacting Hendrickson..... 3

 Relative Literature 4

 Preparing Trailer for Maintenance Service 4

Introduction..... **5**

 ADB Hub and Rotor..... 5

 Tools Required 6

 Inspection..... 6

 Checking for Seal Leaks..... 6

 Checking for Smooth Rotation 7

 Checking End Play..... 7

Removing and Installing Hub **9**

 Hub Removal 9

 Spindle Preparation..... 10

 Preparing Hub for Re-Installation..... 10

 Installing Precision Spindle Nut System & Wheel Bearing Adjustment 11

Inspecting Hub Installation **13**

 Install Hubcap 13

 Adding Oil Lubricant 14

 Completing Installation..... 15

Additional Information **15**

 Torque Values 15

 Wheel Stud Removal and Installation Procedure..... 15

LIST OF TABLES

Relative wheel-end literature 4

List of required tools 6

HXL3® Wheel-end fastener torque values 15



IMPORTANT SAFETY NOTICES

Hendrickson literature number T12007 *Technical Procedure General Safety Precautions and Information*, available at www.Hendrickson-intl.com/TrailerLit, includes important preparation, precautionary and safety information pertaining to the procedures included in this document.

To help prevent personal injury and equipment damage; warnings, cautions and other relative statements included in Hendrickson literature number T12007 are to be read carefully and applied during the performance of the procedures included in this document.

Improper maintenance, service or repair can cause damage to the vehicle and other property, personal injury, unsafe operating conditions and potentially void the manufacturer's warranty.

CONVENTIONS APPLIED IN THIS DOCUMENT

Various techniques are used in this document to convey important information, express safety issues, provide methods for CONTACTING HENDRICKSON and how to identify and apply HYPERLINKS.

EXPLANATION OF SIGNAL WORDS

Hazard signal words (such as DANGER, WARNING or CAUTION) appear in various locations throughout this publication. Information accented by one of these signal words must be observed at all times. Additional notes are utilized to emphasize areas of procedural importance and provide suggestions for ease of repair. The following definitions comply with ANSI Z535.6 and indicate the use of safety signal words as they appear throughout the publication.

▲DANGER Indicates a hazardous situation that, if not avoided, will result in death or serious injury.

▲WARNING Indicates a hazardous situation that, if not avoided, could result in death or serious injury.

▲CAUTION Indicates a hazardous situation that, if not avoided, could result in minor or moderate injury.

NOTICE Indicates information considered important, but not hazard-related (e.g. messages relating to property damage).

IMPORTANT: An operating procedure, practice or condition that is essential to emphasize.



Safety Alert Symbol used to indicate a condition exists that, if not avoided, may result in personal injury or harm to individuals. It must be applied to DANGER, WARNING and CAUTION statements, which emphasize severity.

HYPERLINKS

Hyperlinks are identified by a dark grey line under the linked text. Internal links allow the reader to jump to a heading, step or page in this document. External links open the website or document referenced. While viewing electronically, activate the hyperlink by clicking on the underlined text.

CONTACTING HENDRICKSON

Contact Hendrickson Trailer Technical Services for technical assistance as needed. To do so, several options are available. Technical Services must be contacted before performing any warranty related service.

NOTE: DO NOT service a suspension or any component that is under warranty without first contacting Hendrickson Technical Services.

Prior to contacting Technical Services, it is best to have the following information about the vehicle and Hendrickson suspension available (all that apply):

- **Hendrickson suspension** information, (refer to L977 Suspension and Axle Identification) –
 - Suspension model number
 - Suspension serial number
 - Approximate number of suspension miles
- **Trailer information** (located on VIN plate) -
 - Type (van, reefer, flat bed, etc...)
 - Manufacturer
 - VIN (vehicle identification number)
 - In-service date¹
 - Fleet/owner name
 - Unit #

¹ If the in-service date is unknown or not available, the vehicle date of manufacture will be substituted.



• Failure information

- Description of the system problem, the part number and/or the part description of the reported non-functioning part.
- **Date of failure.**
- Where applicable, **location of problem** on suspension / trailer (e.g., road side, front axle, rear axle, curb side rear, etc.).

• **Digital photos** of suspension and damaged areas.

• **Special application** approval documentation (if applicable).

PHONE

Contact **Hendrickson Trailer Technical Services** directly in the United States and Canada+ at **866-RIDEAIR (743-3247)**. From the menu, select:

- **Technical Services/Warranty** for technical information.
- Other selections include:
 - **Aftermarket Sales** for replacement parts information and ordering.
 - **Original Equipment Sales** for parts inquiries and ordering for trailer manufacturers.

EMAIL

HTTS@Hendrickson-intl.com

Contact Hendrickson for additional details regarding specifications, applications, capacities, and operation, service and maintenance instructions.

All applications must comply with applicable Hendrickson specifications and must be approved by the respective vehicle manufacturer with the vehicle in its original, as-built configuration.

RELATIVE LITERATURE

If you suspect your version of this or any other Hendrickson manual is not “up-to-date”, the most current version is free online at:

www.Hendrickson-intl.com/TrailerLit

Available Hendrickson documentation can be viewed or downloaded from this site.

All Hendrickson online documentation is in PDF format that requires PDF reader software to open. A free application is downloadable from Adobe at <http://get.adobe.com/reader/>.

Other relative literature may include:

NAME	DESCRIPTION
L578	<i>Preventive Maintenance Guide</i>
L583	<i>Comprehensive Warranty Statement</i>
L974	<i>Drum Brake Maintenance Procedures</i> , heading “RETRACTING THE BRAKE SHOES OR SLACK ADJUSTER CONTROL ARM(S)”
T70003	<i>Trailer Decal: HXL3® Wheel-End ID</i>
T70004	<i>Hubcap Decal: HXL3® Wheel-End ID</i>
T71004	<i>Hub and Rotor Assembly and Caliper Mounting Procedures</i>
T71005	Poster: <i>PRECISION Nut Installation Procedures</i>
T77001	<i>PRECISION320® Nut Compatibility</i>
T77002	<i>PRECISION240® Nut Compatibility</i>
T82006	<i>Stud Replacement Procedure</i>

Table 1: Relative wheel-end literature

Hendrickson reserves the right to make changes and improvements to its products and publications at any time. Consult the Hendrickson website

www.Hendrickson-intl.com/TrailerLit

for the latest version of this manual.

PREPARING TRAILER FOR MAINTENANCE SERVICE

Information for trailer preparation, safety and precautionary statements, refer to Hendrickson literature number [T12007](#), available at www.Hendrickson-intl.com/TrailerLit.

NOTE: DO NOT service a suspension or any components that is under warranty without first contacting Hendrickson Technical Services. Refer to [CONTACTING HENDRICKSON](#) for details.

⚠WARNING DO NOT work under a trailer supported only by jacks. Jacks can slip or fall over, resulting in serious personal injury. Always use safety stands to support a raised trailer.

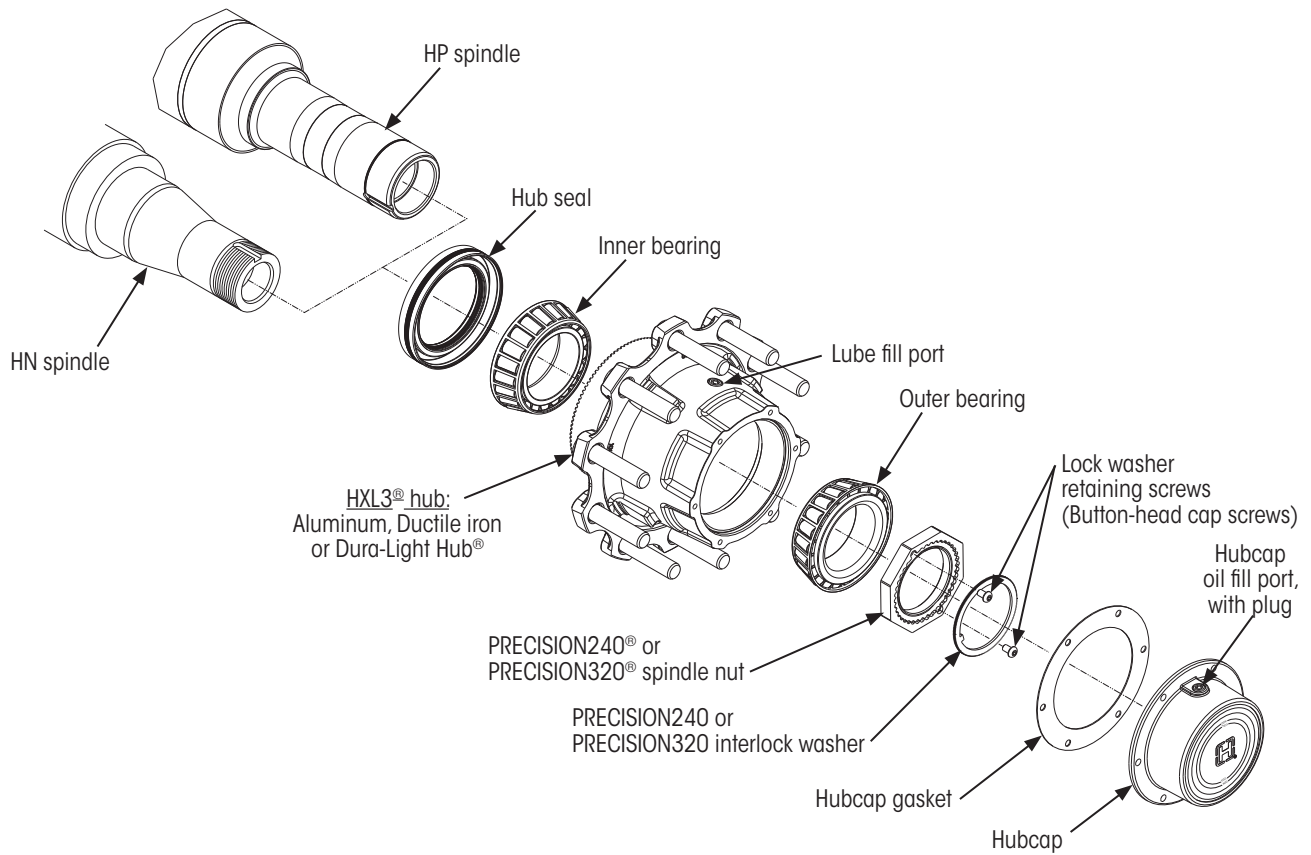

Figure 1: HXL3® Hendrickson Extended-Life 3-year System™ wheel-end parts identification

INTRODUCTION

The hub assembly on HXL3® Hendrickson Extended-Life 3-year System™ (front cover and Figure 1) comes pre-assembled, adjusted and lubricated on a Hendrickson dressed axle. Hendrickson controls the assembly, internal cleanliness, bearing adjustment and seal installation in our facilities, providing premium performance and an extended-service warranty from a trusted source.

The field serviceable HXL3 wheel-end features Hendrickson authorized components:

- Ductile iron, aluminum or Dura-Light Hub® and premium seal.
- SAE 75W-90 synthetic gear lubricant or SAE 80W-90 gear lubricant.
- Hendrickson's PRECISION240 Nut System (on HN spindle) or PRECISION320 Nut System (on HP spindle).

DO NOT remove the hubcap or attempt any kind of field service without first CONTACTING HENDRICKSON Technical Services. **Wheel-end repairs performed prior to contacting Hendrickson Technical Services voids the warranty. Refer to L583 for details.**

NOTE: Hendrickson recommends HP spindle type for offset super single tire applications. Refer to Hendrickson literature number L846 Wide Base Tire Configurations for more details. The HN spindle design is not approved for use with any offset single wheel.

ADB HUB AND ROTOR

For air disc brake (ADB) systems, the caliper must be removed before removing the hub and rotor assembly. ADB rotor and caliper mounting is defined in Hendrickson literature number T71004 Hub and Rotor Assembly and Caliper Mounting Procedures. Original mounting hardware must be discarded, once removed, and replaced with new hardware during reassembly.

Procedures for service and repair of Hendrickson's MAXX22T® trailer air disc brake system can be found in Hendrickson literature number T72009. For component replacement and repair of ADB systems and rotors manufactured by other vendors, links to Bendix, ConMet, Haldex and Wabco literature is available at

www.hendrickson-intl.com/TrailerLit.



TOOLS REQUIRED

The following tools may be required during the performance of some maintenance procedures:

TOOL		WHERE USED
Torque Wrench (10 - 200 ft. lbs. or 13 - 271 Nm)		To be used with sockets listed in this table.
HN	3 ¹³ / ₁₆ inch socket	INSTALLING PRECISION SPINDLE NUT SYSTEM & WHEEL BEARING ADJUSTMENT on page 11
	5 ⁵ / ₃₂ inch hex key	
HP	4 ⁷ / ₈ inch socket	
	3 ³ / ₁₆ inch hex key	
1/2 inch socket		INSTALL HUBCAP on page 13
1/4 or 5/16 inch hex key		Lube fill port plug (Figure 1)
Dial Indicator, with mounting stand (resolution to 0.0001", 0.002 mm)		End-play measurement (Figure 4 on page 7)

Table 2: List of required tools

IMPORTANT: Torque (Table 3 on page 15) cannot be properly applied with an ordinary wrench. A calibrated torque wrench must be used to tighten fasteners to specified values.

INSPECTION

At regular intervals, the HXL3® hub assembly should be checked for seal leaks and smooth rotation.

WARNING Prior to performing inspection procedures, help ensure conditions are safe by following section **PREPARING TRAILER FOR MAINTENANCE SERVICE**.

NOTE: Recommended inspection intervals are based on an average trailer usage of 100,000 miles (160,000 km) per year. Higher usage would require more frequent inspections. Refer to Hendrickson literature number **L578 Suspension Preventive Maintenance Guide** for more details.

Inspections should be performed:

- **Daily** pre-operation check. This would include a general walk around to check for signs of obvious damage, wear or other abnormalities.
- **Every month**, visually inspect back of hub and hubcap gasket for leakage. Refer to the section titled **CHECKING FOR SEAL LEAKS** for complete inspection details.
- **Every three to four months:**
 - Perform monthly inspection.
 - Check for smooth rotation.

- » Refer to the section titled **CHECKING FOR SMOOTH ROTATION** for details.
- » If assistance is required or the hub feels rough, sounds noisy or does not rotate freely, refer to **CONTACTING HENDRICKSON Technical Services** department for further assistance.

- **During brake service** - at this time, wheels are removed making it easy to perform quarterly inspections.

Refer to Hendrickson literature number **L578** for additional recommended suspension inspection procedures.

CHECKING FOR SEAL LEAKS

The HXL3® hub assembly is filled with oil at the factory during the assembly process. Oil is contained in the hub by the hub seal where leakage can occur (Figure 1 on page 5).

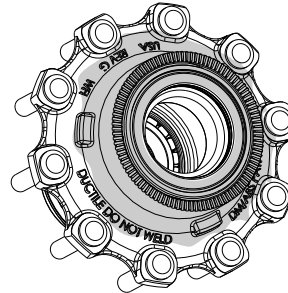

Figure 2: Check back side of hub for leaking oil

To check for leaks, look at the inboard side of the hub, (Figure 2). A small amount of oil may be visible at the hub seal. **This is a normal occurrence and does not necessarily indicate a seal leak.** Wipe clean.

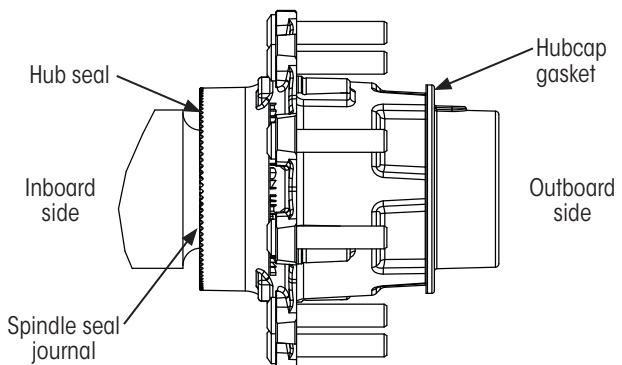

Figure 3: Areas where leaks may occur

A small amount of oil may also appear at the spindle bearing shoulder to hub joint and hubcap gasket (Figure 3). **This is also normal and does not necessarily indicate a leak.** It should be wiped clean to minimize any accumulation of dirt.



NOTICE

Pressure or steam washing should be avoided in this area as water could be forced past the seal, degrade lubricant performance and corrode bearings.

If the hub seal or gasket is leaking, a large quantity of oil will be present in the areas of the hub, spindle hubcap and wheel. If found, refer to CONTACTING HENDRICKSON Technical Services for guidance on how to proceed.

CHECKING FOR SMOOTH ROTATION

Many factors can effect smoothness of rotation. Primary causes include:

- Bearing wear
- Damaged hub seal
- Debris

NOTE: A reasonable assessment can be performed without removing tires and rims. However, this procedure is best performed with hub only as shown in Figure 5 on page 8.

1. **Ensure** trailer is secure per PREPARING TRAILER FOR MAINTENANCE SERVICE on page 4.
2. **Disengage** brakes and remove brake drum (recommended).
3. While maintaining physical contact, **slowly rotate** hub in both directions at least five revolutions.
4. **During rotation**, ensure smooth and quiet rotation. Bearings should move smoothly. Feel for any resistance in movement. Any debris in bearings should be felt as it moves over rollers in bearings.

IMPORTANT: If bearings feel rough, sound noisy or **DO NOT** rotate freely, **DO NOT** place the suspension back into service. Refer to CONTACTING HENDRICKSON Technical Services for guidance.

CHECKING END PLAY

This procedure must be performed:

- After CONTACTING HENDRICKSON Technical Services, before removing the hubcap (as stated on hubcap label), for guidance relative to suspected wheel end play movement.
- As part of INSPECTING HUB INSTALLATION on page 13.

1. If not already done so:
 - A. **Ensure** trailer is secure per PREPARING TRAILER FOR MAINTENANCE SERVICE on page 4
 - B. **Remove** wheel (tires and rims).
 - C. **Disengage** brakes.
 - D. If drum brake, **remove** drum (recommended). If ADB, **remove** brake pads per manufacturer's recommended procedures.
 - E. **Drain** oil from wheel end.
 - F. **Remove** hubcap and discard gasket.

IMPORTANT: End play can be checked with brake drum installed or removed (preferred). If installed, **ensure all brake drum wheel fasteners are installed and tightened to manufacturers specifications** before checking end play.

2. **Ensure** the hubcap mounting surface of the hub and end of spindle are **clean and totally free of any burrs or debris**.
3. **Rotate** hub **at least 5 revolutions** to ensure bearings are fully seated.

NOTE: The hub **MUST** be rotated before performing end play measurement. Rotation works the rollers into their fully seated positions against the bearing cone shoulder. **Failure to rotate hub could result in a false end play reading.**

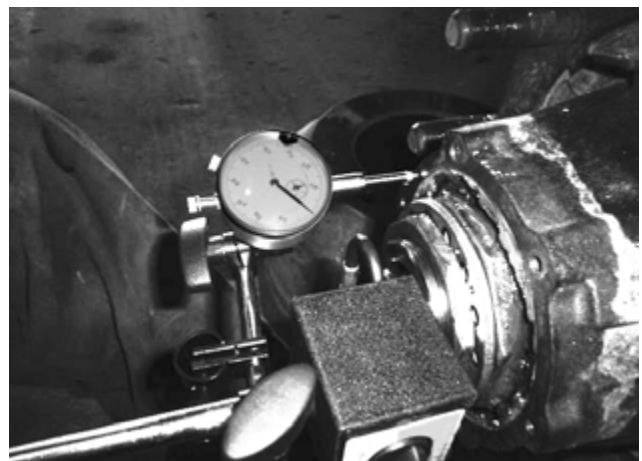

Figure 4: Checking end play

4. **Attach** dial indicator (Table 2) with magnetic base to flat surface at end of spindle (Figure 4).

5. **Adjust** dial indicator so its pointer line of action is parallel to spindle axis and touches the hubcap mounting surface of the hub. Ensure the plunger contacts the hub on a surface that is smooth and fully machined. Any regions with scratches, gouges or non-cleanup should be avoided.
6. **Check** indicator for free movement in both directions. Lightly **push and pull** on indicator arm to verify plunger is free to move at least .005" in each direction. If indicator bottoms out, readjust until it is free to move .005" in both directions.
7. **Zero** indicator.

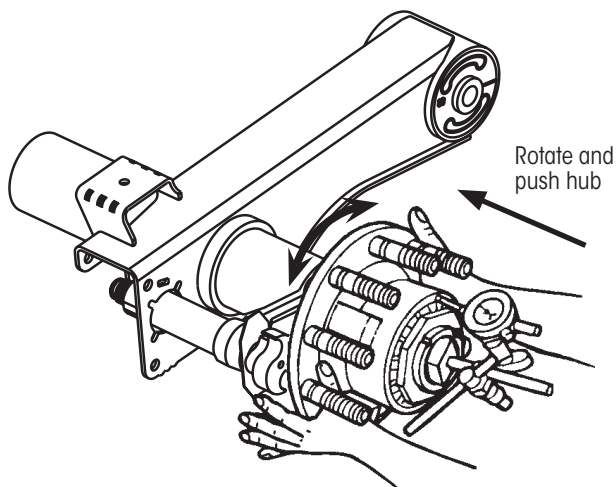

Figure 5: Checking inward end-play

8. **Grasp** hub flange, as shown in Figure 5, and **push the hub inward while rotating** hub slightly in both directions (between two hub cap fastener holes) until the dial indicator reading remains constant. **Record** reading.

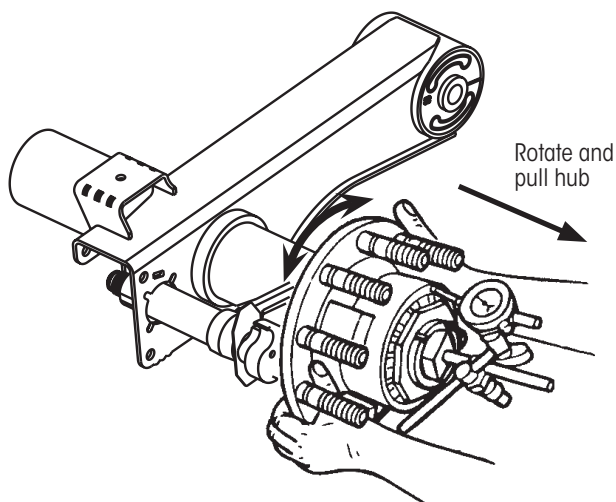

Figure 6: Checking outward end-play

9. While still grasping hub (Figure 6), **pull hub outward while rotating** hub slightly in both directions (between two hub cap fastener holes) until dial indicator reading remains constant. **Record** reading.
10. End play is the total movement of the indicator. **Calculate** difference between recorded values of Step 8 and Step 9 to determine end play, **record** value.

IMPORTANT: End play must be between 0.001" (0.0254 mm) and 0.005" (0.1270 mm). If subsequent readings are necessary, the hub must be rotated at least 5 revolutions to reset the bearings (refer to Step 3).

- A. If checking end play after installation, return to INSPECTING HUB INSTALLATION on page 13, Step 3.
- B. If end play is **more than 0.005"** (0.1270 mm), bearing adjustment is necessary. Refer to INSTALLING PRECISION320® NUT SYSTEM & WHEEL BEARING ADJUSTMENT on page 12.

IMPORTANT: DO NOT place the suspension back into service without correcting the problem.

- C. If end play is **within specification**, no bearing adjustment is necessary. Refer to Figure 12 on page 12 and check to ensure:
 - i. Spindle nut is secure.
 - ii. Interlock and tang are properly seated.
 - iii. Retaining screws are securely in place.

11. If not already done so, perform CHECKING FOR SEAL LEAKS on page 6.
12. Go to INSTALL HUBCAP on page 13.
13. If applicable, reassemble brake wheel-end components.



REMOVING AND INSTALLING HUB

IMPORTANT: To ensure continued warranty, **DO NOT** perform the following procedures without obtaining prior authorization from Hendrickson Trailer Technical Services. Refer to CONTACTING HENDRICKSON for contact information.

NOTE: In order to maintain warranty status, CONTACTING HENDRICKSON is recommended before removing the hubcap and disturbing the precision spindle nut.

⚠WARNING Prior to performing maintenance procedures, ensure conditions are safe by following section PREPARING TRAILER FOR MAINTENANCE SERVICE on page 4.

HUB REMOVAL

Only after receiving proper authorization from Hendrickson Technical Services, use the following procedure to remove the HXL3® hub assembly:

1. **Remove** tire / wheel assembly.
2. **Disengage** brakes and:
If drum brake, **remove** brake drum.
If ADB equipped, **remove** the caliper.
3. **Drain** the oil from the hub.
4. **Remove** hubcap screws, **remove** hubcap and discard gasket.
5. Allow time for oil to **drain** from wheel end.
6. Properly **dispose** of the removed used oil.
7. Using a hex key (TOOLS REQUIRED on page 6), **remove** button-head cap screws from interlock washer Figure 7.
8. **Remove** interlock washer and precision spindle nut (Figure 1 on page 5).

NOTE: Pushing on edge of interlock washer near one of the screw holes will cause the opposite edge to tip away from the nut, allowing easy removal of interlock washer.

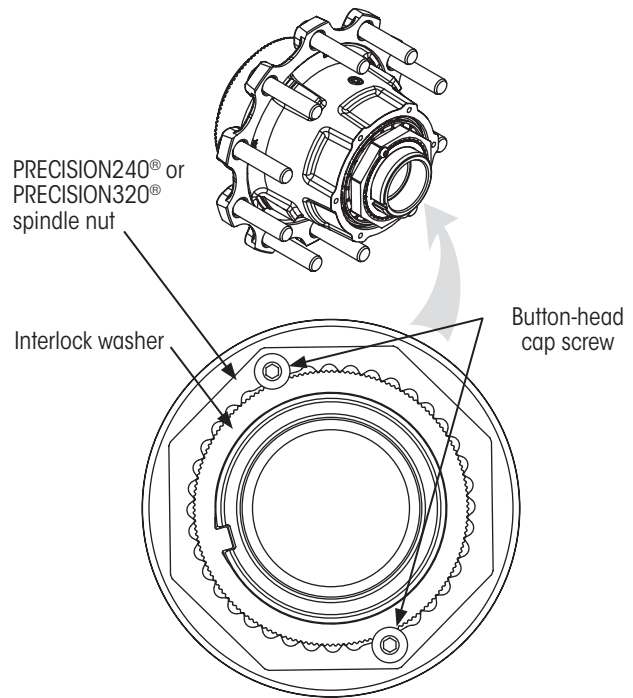

Figure 7: Button-head cap screw on a PRECISION240® or PRECISION320® nut system

9. **Carefully pull HXL3® hub assembly slightly** toward spindle end. A short quick motion should allow outer bearing to exit the hub. Be prepared to catch outer bearing if it slides off the end of the spindle. Otherwise, simply remove it.
 10. **Remove hub from spindle.** The inner bearing is held in the hub by the hub seal and should come off with the hub.
 11. **Remove and discard hub seal:**
 - A. **If the seal is in the hub** - a pry bar can be used to carefully remove the seal from the hub bore. Damage to hub and hub surfaces must be avoided.
 - B. **If the seal is on the spindle** - Using a brass, leather or other soft-faced mallet, drive the seal off the spindle by carefully striking the seal from the back side.
- NOTICE** Any damage to the spindle's machined surfaces can effect wheel end performance.
12. **Remove, clean and inspect** inner bearing. Replace if needed.

SPINDLE PREPARATION

Before installing or re-installing the hub, follow this procedure to ensure spindle machined surfaces are clean and undamaged.

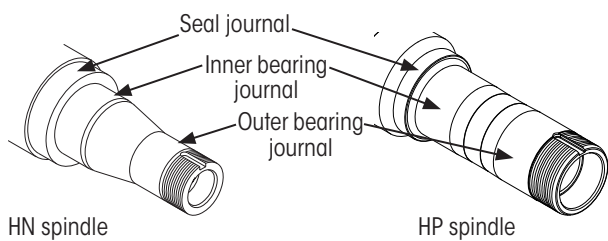

Figure 8: Spindle seal & bearing journals

1. **Remove** old lubricant and thoroughly clean spindle.
2. **Inspect** machined spindle journals (Figure 8) for nicks, scratches, burrs or marks. If needed, use crocus cloth or emery cloth to repair any damaged areas.
3. **Clean** spindle threads and keyway thoroughly with a wire brush to avoid false bearing adjustments and to avoid introduction of contaminants into the lubricant cavity.
4. **Thoroughly clean** spindle machined surfaces of rust, dirt, oil or any other contaminants that could damage the hub seal and cause it to leak.
5. **Lubricate** spindle bearing surfaces with clean oil.

NOTICE

To minimize fretting and damage to wheel-end, lubricate all components and applicable surfaces using the same lubricant.

PREPARING HUB FOR RE-INSTALLATION

The hub and bearings should be cleaned and inspected prior to installation.

CAUTION

For safety reasons, to prevent injury and damage to the hub and spindle, lifting equipment may be required to lift and support the hub as it is being installed onto the spindle.

NOTE: If ADB, refer to Hendrickson literature number T71004 *Hub and Rotor Assembly and Caliper Mounting* for servicing the rotor.

If installing new hub, start with [Step 3](#).

1. **Thoroughly clean** the hub bore of any dirt, oil, rust or any other substance that may be present.

2. **Remove** all sharp edges, nicks and burrs from seal bore, hubcap bore and hubcap mounting surface of the hub.
3. **Inspect** hub seal bore for roughness. If needed, use emery cloth to remove any burrs or old bore sealant and wipe hub clean.
4. **Ensure** hubcap mounting surface is smooth and free of debris.

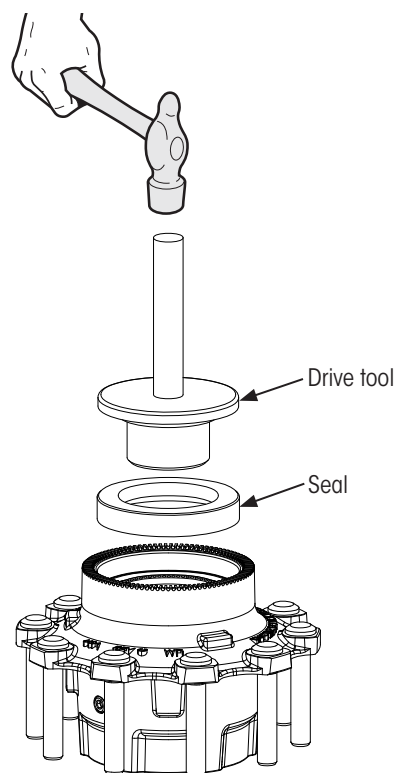

Figure 9: Hub-mounted seal installation

5. **Apply lubricant** to inner bearing.
 6. **Install** inner bearing into hub ([Figure 1](#) on [page 5](#)).
- NOTE:** A hub seal driver ([Figure 9](#)) is recommended and can be obtained from seal manufacturer.
7. **Lubricate** seal according to seal manufacturer's recommendations.
 8. **Place** seal onto the drive tool ([Figure 9](#)) for installation into the hub according to seal manufacturer's instructions.
 - A. **Align** seal tool with hub seal bore.
 - B. **Drive** seal until it bottoms out in the hub seal bore.
 - C. **Rotate** installation tool and apply several light blows to ensure seal is properly seated.

- D. Check inner bearing to ensure it rotates freely.

HUB AND OUTER BEARING ASSEMBLY

With seal and inner bearing in place; the hub and the outer bearing can now be installed onto the spindle; in that order.

CAUTION For safety reasons, to prevent injury and damage to the hub and spindle, lifting equipment may be required to lift and support the hub as it is being installed onto the spindle.

1. Taking care not to damage the seal, **gently slide** the hub onto spindle until the seal is against the spindle seal journal (Figure 8).

NOTICE The HUB SEAL CAN BE DAMAGED if:

- Hub seal is improperly installed.
- Hub seal is rammed into the spindle bearing shoulder.
- Hub is not kept supported and aligned with spindle until the outer bearing and axle nut are installed.
- Lubricant types are mixed during hub assembly.

2. **Support** and do not allow hub to move off center while completing the assembly.
3. **Lubricate the** outer bearing and slide onto hub.
4. **Clean** as needed to remove lubricant from unwanted areas.

NOTE: While sliding hub onto spindle, lubricant is collected at the spindle seal journal inboard of the hub (Figure 3 on page 6). This may be later interpreted as a oil/grease leak and should be cleaned.

5. Continue with INSTALLING PRECISION SPINDLE NUT SYSTEM & WHEEL BEARING ADJUSTMENT.

INSTALLING PRECISION SPINDLE NUT SYSTEM & WHEEL BEARING ADJUSTMENT

Available precision spindle nut systems for HXL3® include:

SPINDLE	NUT SYSTEM	TOOLS
HN	PRECISION240®	3 ¹³ / ₁₆ inch socket
		5 ⁵ / ₃₂ inch hex key
HP	PRECISION320®	4 ⁷ / ₈ inch socket
		3 ³ / ₁₆ inch hex key

Installation procedures are the same, but part and tool sizes (Table 2 on page 6 and above table) are different due to the difference in spindle thread diameters.

NOTICE Failure to exactly follow the steps of this procedure could cause improper bearing seating, resulting in reduced bearing life.

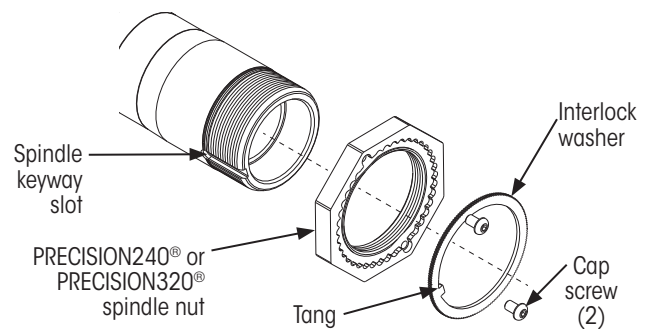

Figure 10: Precision spindle nut system components

WARNING FAILURE TO FOLLOW THESE INSTRUCTIONS COULD CAUSE WHEEL TO COME OFF AND CAUSE BODILY INJURY.

OVER-TIGHTENING NUT COULD CAUSE BEARINGS TO RUN HOT AND BE DAMAGED.

1. **Install precision spindle nut** (Figure 10) onto the spindle, toothed side out, and **hand-tighten**.
2. Simultaneously **rotate hub** clockwise **at least three revolutions**, while using a torque wrench to tighten precision spindle nut to 200 ft. lbs. (271 Nm) of torque.
3. **Back off** precision spindle nut 1 revolution.
4. **Rotate** hub clockwise at least one full revolution.
5. **Tighten** precision spindle nut to 50 ft. lbs. (68 Nm) of torque.



6. **Rotate** hub clockwise three full revolutions.
7. **Repeat** Step 5 and Step 6 three more times.

IMPORTANT: **DO NOT rotate** the hub at this point. Rotating the hub before installing the interlock washer can dislodge the precision spindle nut and cause improper bearing seating.

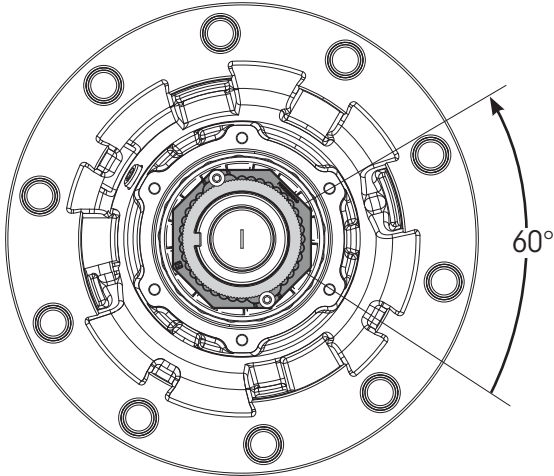

Figure 11: Back off nut 1/6 turn

8. **Back-off** nut 1/6 turn (Figure 11, one hubcap screw hole).

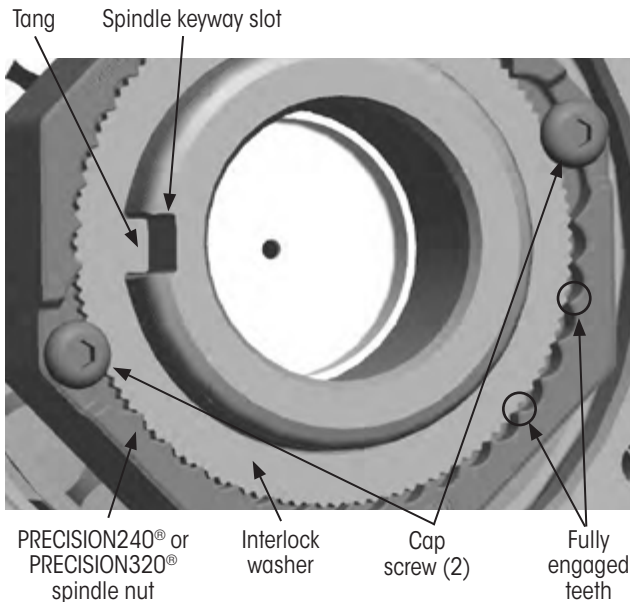

Figure 12: Interlock washer and precision spindle nut fully engaged

9. **Install interlock washer** into the precision spindle nut with the tang aligned and inserted in the spindle keyway as shown in Figure 10 and Figure 12.

If washer and nut teeth do not align, **DO NOT ROTATE NUT**. Flip interlock washer over and reinstall.

NOTE: The PRECISION240® and PRECISION320® interlock washer and nut are designed so that one side of the washer will always engage the spindle nut teeth without readjusting the nut.

IMPORTANT: Teeth between the interlock washer and precision spindle nut must fully engaged as shown in Figure 12. **DO NOT ADJUST NUT TO ALIGN INTERLOCK WASHER**. Flip the washer over and reinstall.

10. **Install two button-head cap screws** (Figure 10) into the precision spindle nut until the heads of the screws just contact the face of the nut.

11. **Tighten cap screws** to:



SPINDLE TYPE	PRECISION NUT SYSTEM	CAP SCREW TORQUE	
		ft. lbs.	Nm
HN	PRECISION240®	10±2	13.5±2
HP	PRECISION320®	15±2	20±2

INSPECTING HUB INSTALLATION

To ensure correct installation, follow these procedures:

1. **Ensure** interlock washer is fully seated in PRECISION240® or PRECISION320® spindle nut (Figure 12).
2. **Ensure** heads of both cap screws contact the nut face.
3. **Check end play** using CHECKING END PLAY on page 7.

If end play is **between 0.001 (0.0254 mm) and 0.005" (0.1270 mm)**, continue to INSTALL HUBCAP.

If **excessive end-play** (nut is too loose):

- A. **Remove** two cap screws and pull interlock washer away from nut, but not off spindle.
- B. **Hand** tighten precision spindle nut until next washer tooth is aligned.

NOTE: Apply a small amount of Loctite® Threadlocker Blue to screw threads.

- C. **Reassemble** interlock washer and button-head cap screws.
- D. **Return** to CHECKING END PLAY on page 7.

If **insufficient end-play** (over clamped):

- A. **Remove** two cap screws and pull interlock washer away from nut, but not off spindle.
- B. **Back-off** precision spindle nut until next washer tooth is aligned.

NOTE: Apply a small amount of Loctite® Threadlocker Blue to screw threads.

- C. **Reassemble** interlock washer and button-head cap screws.
- D. **Return** to CHECKING END PLAY on page 7.

NOTE: If the above steps have already been performed and end play is still out of tolerance, return to HUB REMOVAL on page 9 to remove and reinstall hub. If difficulty continues, refer to CONTACTING HENDRICKSON on page 3.

4. **Perform** the CHECKING FOR SMOOTH ROTATION on page 7.

INSTALL HUBCAP

After hub installation and inspection is complete, the hubcap can be installed.

IMPORTANT: **Always** install a new gasket when reinstalling hubcap.

NOTICE

Interference between precision spindle nut system and hubcap could occur if improper components are used. Use only genuine Hendrickson or Hendrickson approved replacement components. Refer to RELATIVE LITERATURE on page 4 or CONTACTING HENDRICKSON on page 3 as needed.

1. **Visually inspect** hubcap, hub mating surface, bolt holes and new gasket for:
 - Signs of damage
 - Debris, such as silicon gasket sealer
 - Burrs or sharp edges
 - Cracks
2. **Clean, repair or replace** as needed.
3. **Align** hubcap and new gasket onto hub and **insert** bolts.
4. **Hand-tighten** bolts.
5. Using a star pattern, **torque** hubcap screws to 15±3 ft. lbs. (20±4 Nm) torque.

NOTICE

DO NOT overtighten hubcap screws. Overtightening will distort metal hubcap mounting flange, which will prevent hubcap from achieving a leak-free seal.



ADDING OIL LUBRICANT

Oil lubricant must be added after hub assembly and as needed. SAE 75W-90 synthetic gear lubricant or SAE 80W-90 gear lubricant is approved for use in the HXL3® wheel-end hub.

IMPORTANT: Use of improper lubricants or maintenance procedures can void the wheel-end warranty.

NOTICE To minimize fretting and damage to wheel-end, lubricate all components and applicable surfaces using the same lubricant.

1. **Remove** fill port plug (Figure 1 on page 5) on the side of the hub.

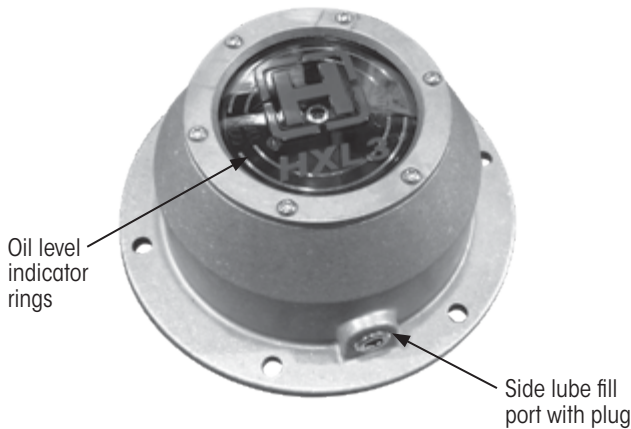

Figure 13: HXL3 oil hubcap with oil level indicator rings

NOTE: Not all hubs have a fill port. In this case, oil can only be added through the hubcap side lube fill port (Figure 13).

2. **Fill** wheel end with SAE 75W-90 synthetic gear lubricant or SAE 80W-90 gear lubricant to "FULL" line on hubcap window as shown in Figure 13 and Figure 14.

NOTE: Allow sufficient time for oil to settle prior to final oil level check (it may be necessary to add oil more than once to adequately fill the wheel end).

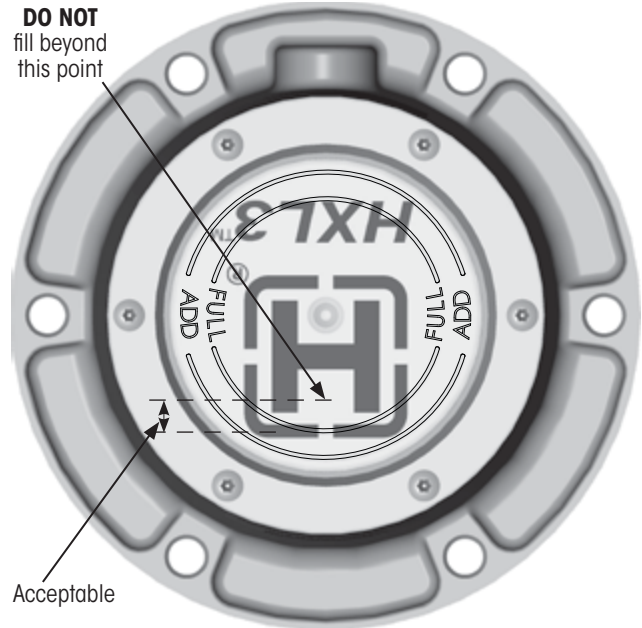

Figure 14: Fill levels for oil lubricant

NOTICE The oil level should be maintained to the hubcap FULL indicator ring shown in Figure 14. Oil can be added to exceed the FULL line, but must remain below the lowest hole on the spindle end plug (vent or supply line hole). Oil levels above this risk contamination and loss of oil through the axle plus a reduction in lubricating performance.

If the lubricant is at or below the ADD line there is a risk of damage to bearings and other wheel-end components.

NOTE: Hendrickson HXL3® wheel-ends do not vent at the hubcap. A vent tube is provided at the axle.

3. **Check** oil level at hubcap window (Figure 14).
 - A. **If** oil was inserted through the fill port in the **hub**, Install fill port plug and tighten to 22±2 ft. lbs. (30±2 Nm) of torque.
 - B. **If** oil was inserted through **hubcap** side fill port, Install fill port plug and tighten to 7±2 ft. lbs. (10±2 Nm) of torque.
4. **Spin hub** more than three revolutions to distribute oil.



COMPLETING INSTALLATION

1. **Spin hub** more than three revolutions to distribute lubricant equally in hub bore.
2. If drum brake, **Install brake drum**
3. If ADB, **install brake caliper** according to manufacturer's procedures. Refer to Hendrickson literature number T71004 Hub and Rotor Assembly and Caliper Mounting for information to reassemble ADB rotor and brake components. New caliper mounting hardware must be used.
4. **Install wheel** (tire and rim assembly) Refer to Brake DRUM AND WHEEL ASSEMBLY in Hendrickson literature number T82006 Stud Replacement Procedures.

ADDITIONAL INFORMATION

TORQUE VALUES

Table 3 lists torque values for HXL3® wheel-end fasteners.

FASTENER	TORQUE	
	ft. lbs.	Nm
Hubcap screws	15±3	20±4
Hub fill port plug	22±2	30±3
Hubcap fill port plug	7±2	9±3
PRECISION240® cap screws	10±2	13±2
PRECISION320® cap screws	15±2	20±2
Wheel Nuts ^{1,2}	475±25	644±25

¹ These fasteners are incrementally tightened according to procedures defined in this manual and superseded by OE documentation, where applicable. Refer to decal T70013 *Wheel Assembly Procedure*.

² Re-torque all wheel nuts after 50 to 100 miles of service.

Table 3: HXL3® Wheel-end fastener torque values

WHEEL STUD REMOVAL AND INSTALLATION PROCEDURE

Refer to Hendrickson literature number T82006 Stud Replacement Procedures for detailed instructions on wheel stud removal for both drum and disc applications.

Actual product performance may vary depending upon vehicle configuration, operation, service and other factors.

Call Hendrickson at 866.RIDEAIR (743.3247) for additional information.



www.hendrickson-intl.com

TRAILER COMMERCIAL VEHICLE SYSTEMS

2070 Industrial Place SE
Canton, OH 44707-2641 USA
866.RIDEAIR (743.3247)
330.489.0045 • Fax 800.696.4416

Hendrickson Canada

250 Chrysler Drive, Unit #3
Brampton, ON Canada L6S 6B6
800.668.5360
905.789.1030 • Fax 905.789.1033

Hendrickson Mexicana

Circuito El Marqués Sur #29
Parque Industrial El Marqués
Pob. El Colorado, Municipio El Marqués,
Querétaro, México C.P. 76246
+52 (442) 296.3600 • Fax +52 (442) 296.3601

T72006 Rev B 04-20 ECN 33415 Rev A 03-18 ECN 30197 03-13 ECN 21572

© 2013 - 2020 Hendrickson USA, L.L.C. All Rights Reserved. All trademarks shown are owned by Hendrickson USA, L.L.C., or one of its affiliates, in one or more countries.
Information contained in this literature was accurate at the time of publication. Product changes may have been made after the copyright date that are not reflected.

Printed in United States of America