

H TECHNICAL PROCEDURE SURELOK® INSPECTION

SUBJECT: SURELOK - Restraining Bolt
Prior to 2015

LIT NO: T89010
DATE: February 2021

REVISION:

INSPECTING THE RESTRAINING BOLT

Inspect for the presence of the restraining bolt on suspensions prior to 2015, with the SURELOK actuator centered in the rear crossmember. The restraining bolt limits the rearward travel of the SURELOK arm assembly. A missing restraining bolt will allow for the actuator to overextend causing damage to the actuator. If the restraining bolt is not present, use the "INSTALLING THE RESTRAINING BOLT" procedure listed below.

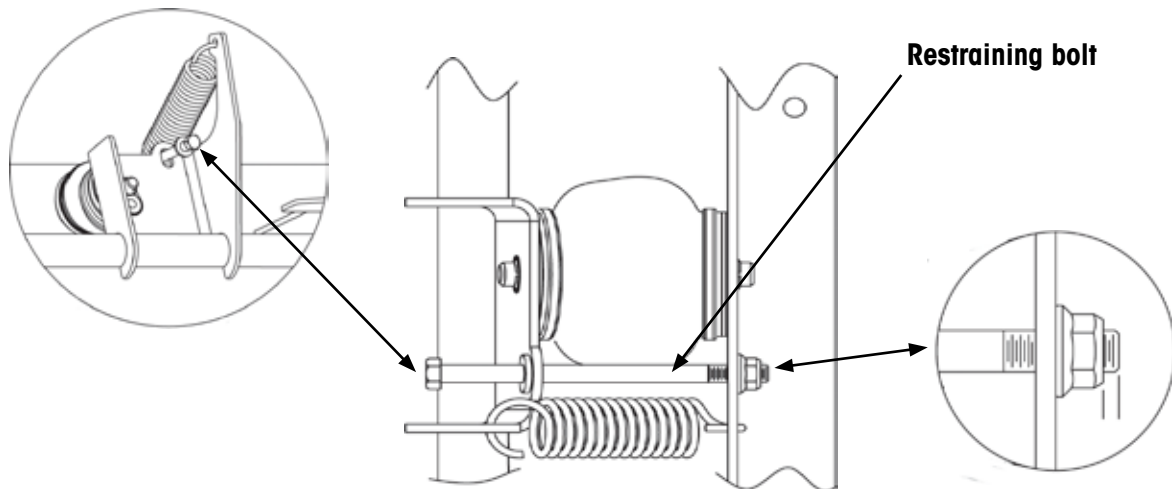

INSTALLING THE RESTRAINING BOLT

1. Slip the 3/8-in. hardened flat washer onto the 3/8 × 6-in. bolt.
2. Insert the bolt and washer assembly through the hole in the actuator bracket and the hole in the rear cross member.
3. Thread the flanged nut on the bolt and tighten only until two threads of the bolt are visible past the nut.

Call Hendrickson at **866.RIDEAIR (743.3247)** for additional information.



www.hendrickson-intl.com

TRAILER COMMERCIAL VEHICLE SYSTEMS
2070 Industrial Place SE
Canton, OH 44707-2641 USA
866.RIDEAIR (743.3247)
330.489.0045 • Fax 800.696.4416

Hendrickson Canada
250 Chrysler Drive, Unit #3
Brampton, ON Canada L6S 6B6
800.668.5360
905.789.1030 • Fax 905.789.1033

Hendrickson Mexicana
Circuito El Marqués Sur #29
Parque Industrial El Marqués
Pob. El Colorado, Municipio El Marqués,
Querétaro, México C.P. 76246
+52 (442) 296.3600 • Fax +52 (442) 296.3601