

# **H** ASSEMBLY INSTRUCTIONS

## HAULMAAX® Rear Suspension Load Spring Service Kit for Vehicle Weight Bias

SUBJECT: Kit No. 60961-746

LIT NO: 59310-047

DATE: September 2014

REVISION: B

### INTRODUCTION

This publication is intended to assist maintenance personnel with the installation of the load springs for HAULMAAX® equipped vehicles with a weight bias. Hendrickson's progressive load spring (Service Kit No. 60961-746) is available for HAULMAAX 400/460 suspensions, see Figure 1.

Refer to Hendrickson Publication No. 17730-244 for complete service and safety instructions for the HAULMAAX rear suspension.

#### HAULMAAX Load Spring Weight Bias Service Kit No. 60961-746

DESCRIPTION	QTY.
Progressive Load Spring	1
Auxiliary Load Spring	1
Load Spring Shim	2
½" 13 UNC Flange Bolt	10
½" 13 UNC Flange Nut	10

FIGURE 1

PROGRESSIVE Load Spring



AUXILIARY Load Spring



This load spring for weight bias service kit is:

- intended to help adjust for vehicle lean conditions that may be induced by a side-to-side vehicle weight bias that is found with particular types of vehicle bodies or vehicle-mounted equipment used in certain applications (including, but not limited to, side-loading refuse and well driller).
- not intended to address vehicle lean conditions caused by worn or damaged vehicle components, such as: twisted frames or worn body mounts.
- not intended for vehicle lean conditions that can be eliminated by re-distributing vehicle cargo or other loads. **Prior to purchasing or installing a load spring for weight bias service kit**, first re-distribute any such loads that may be causing a side-to-side vehicle weight bias.

### INSPECTION

Prior to the weight bias load spring installation, visually inspect the vehicle for worn or damaged components and repair or replace as necessary.

### VEHICLE LEAN EVALUATION

1. Place the vehicle on a level floor.
2. Chock the wheels.
3. Measure the distance from the bottom of the frame to the ground on both sides of the vehicle just ahead of the tandem.
4. Determine if the vehicle fulfills the weight bias criteria. If the frame to ground measurements:
  - a. **are within** the vehicle manufacturer's level chassis specification, do not install the load spring for weight bias service kit. Remove wheel chocks.
  - b. **are not within** the vehicle manufacturer's level chassis specification, then the load spring for weight bias service kit can be installed on the vehicle.

## WEIGHT BIAS LOAD SPRING KIT INSTALLATION

**NOTE** If equipped with a progressive load spring *on the heavy side* or auxiliary load spring *on the light side* and in acceptable condition (3" in height with the vehicle un-loaded), it is acceptable to eliminate the load spring replacement procedure for that side and install the replacement load spring on the opposite side of the tandem as needed for the weight bias configuration.

**SERVICE HINT** Tire removal is not necessary for the replacement of the load spring assembly.

**NOTE** Install the progressive load spring on the low (heavy) side of the vehicle and the auxiliary load spring on the high (light) side.

### DISASSEMBLY

1. Chock the wheels.

THE VEHICLE MUST BE FIRMLY SUPPORTED WITH JACK STANDS PRIOR TO SERVICING. FAILURE TO DO SO CAN RESULT IN PERSONAL INJURY OR PROPERTY DAMAGE.

2. Remove the three (3) ½" flange load spring mounting fasteners.
3. Remove the load spring **spacer** on both sides of the vehicle, see Figure 2.
4. Raise the frame of the vehicle until there is sufficient gap between the **load spring** and the **load spring shims**. Support the frame at this height, see Figure 3.

**FIGURE 2**

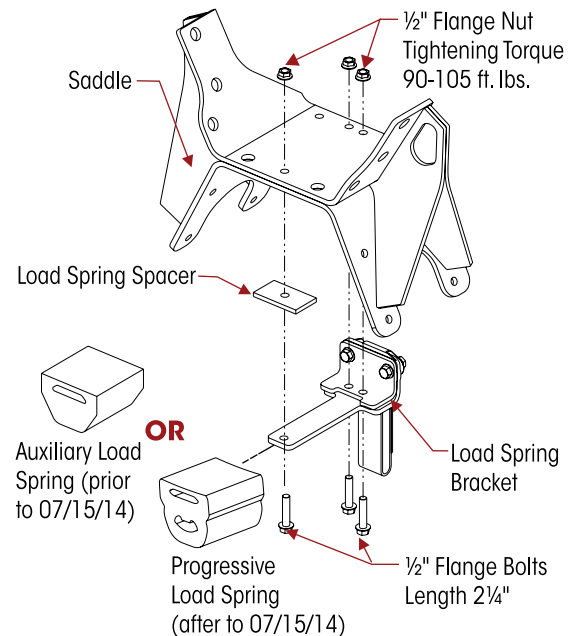

5. Remove and discard the springs from both sides of the vehicle and, see Figure 2.
6. Remove the load spring shim fasteners and shims, unless equipped with two (2) load spring shims in condition are installed, then proceed to assembly.

**FIGURE 3**

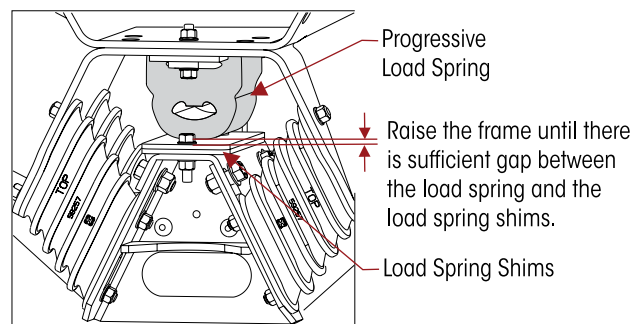

### ASSEMBLY

THE HAULMAAX SUSPENSION MUST HAVE A MINIMUM OF ONE (1) LOAD SPRING SHIM PER SIDE OF THE VEHICLE.

1. Install two (2) load spring shims per side and ½" fasteners, see Figure 3.
2. Install the progressive load spring on the load spring bracket to the low (heavy) side of the vehicle, see Figure 4.

**WARNING**

**WARNING**

**FIGURE 4**

3. Position the load spring bracket and install the ½" load spring mounting fasteners. Ensure the load spring spacer is installed on the outboard fastener between the load spring bracket and the saddle assembly.
4. Install the new auxiliary load spring on the spring bracket to the high (light) side of the vehicle, see Figure 4.
5. Position the load spring bracket and install the ½" load spring mounting fasteners. Ensure the load spring spacer is installed on the outboard fastener between the load spring bracket and the saddle assembly.
6. Tighten all load spring and shim ½" mounting fasteners to 90-105 foot pounds.
7. Remove the frame supports and lower the vehicle.

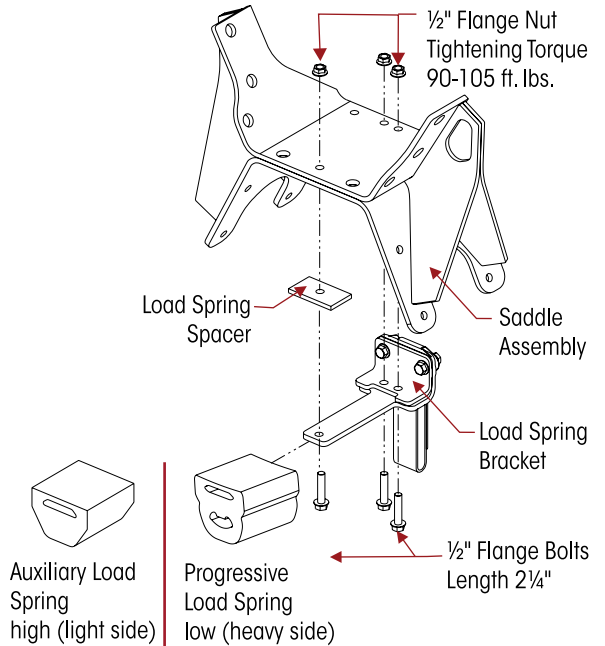

## RE-EVALUATE VEHICLE LEAN

**NOTE**

A minimum of one (1) load spring shim per side is required. Shim count must not vary from side to side of the vehicle by more than (2) shims.

1. Chock the vehicle (disregard if chocks are already in place).
2. Measure the distance from the bottom of frame to ground on both sides of the vehicle just ahead of the tandem.
3. If the frame to ground measurements:
  - a. **are within** the vehicle manufacture’s specification for a level chassis, then no further adjustment is needed and wheel chocks can be removed.
  - b. **are not within** the vehicle manufacturer’s specifications for a level chassis then the load spring shims may be adjusted, proceed to the Shim Count Adjustment procedure.

## SHIM COUNT ADJUSTMENT

**NOTE**

Additional load spring shims may be added to the low side, or load spring shims may be removed from the high side. The amount of shims per side must be within two (2) shims from side to side.

**EXAMPLE:**

If there are two (2) load spring shims on the left side of the vehicle then the right side may have as many as four (4) load spring shims or as few as one (1) load spring shim.

1. Raise and support the frame.

**FIGURE 5**

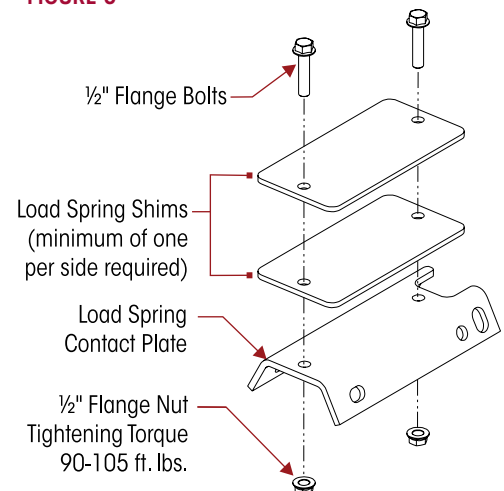



2. Remove the fasteners that attach the load spring shims to the load spring contact plate, see Figure 5.
3. Remove a load spring shim from the light (high) side of the vehicle, or install an additional load spring shim to the heavy (low) side as needed. A minimum of one (1) load spring shim per side is required. Shim count must not vary from side to side of the vehicle by more than (2) shims.

## NOTE

The required bolt length varies with the amount of shims installed. Ensure there are at least three (3) threads exposed past the locknut.

4. Install the fasteners that attach the load spring shims to the load spring contact plate and tighten to 90-105 foot pounds torque, see Figure 5.
5. Return to Re-Evaluate Vehicle Lean until measurement is within specification.
6. Remove wheel chocks.

Refer any questions on this publication to Hendrickson Tech Services



Toll-free U.S. and Canada  
1.866.755.5968  
Outside U.S. and Canada  
1.630.910.2800



Parts Identification  
[truckparts@hendrickson-intl.com](mailto:truckparts@hendrickson-intl.com)  
Technical Support  
[techservices@hendrickson-intl.com](mailto:techservices@hendrickson-intl.com)



1.630.910.2899



Additional Hendrickson  
Product Information  
[www.hendrickson-intl.com](http://www.hendrickson-intl.com)

[www.hendrickson-intl.com](http://www.hendrickson-intl.com)



Truck Commercial Vehicle Systems  
800 South Frontage Road  
Woodridge, IL 60517-4904 USA

1.866.755.5968 (Toll-free U.S. and Canada)  
1.630.910.2800 (Outside U.S. and Canada)  
Fax 1.630.910.2899