

H TECHNICAL PROCEDURE

VANTRAAX® HRRNT 40K /
HRRNT 50K

SUBJECT: Maintenance Procedures

LIT NO: L765

DATE: October 2004 REVISION: A

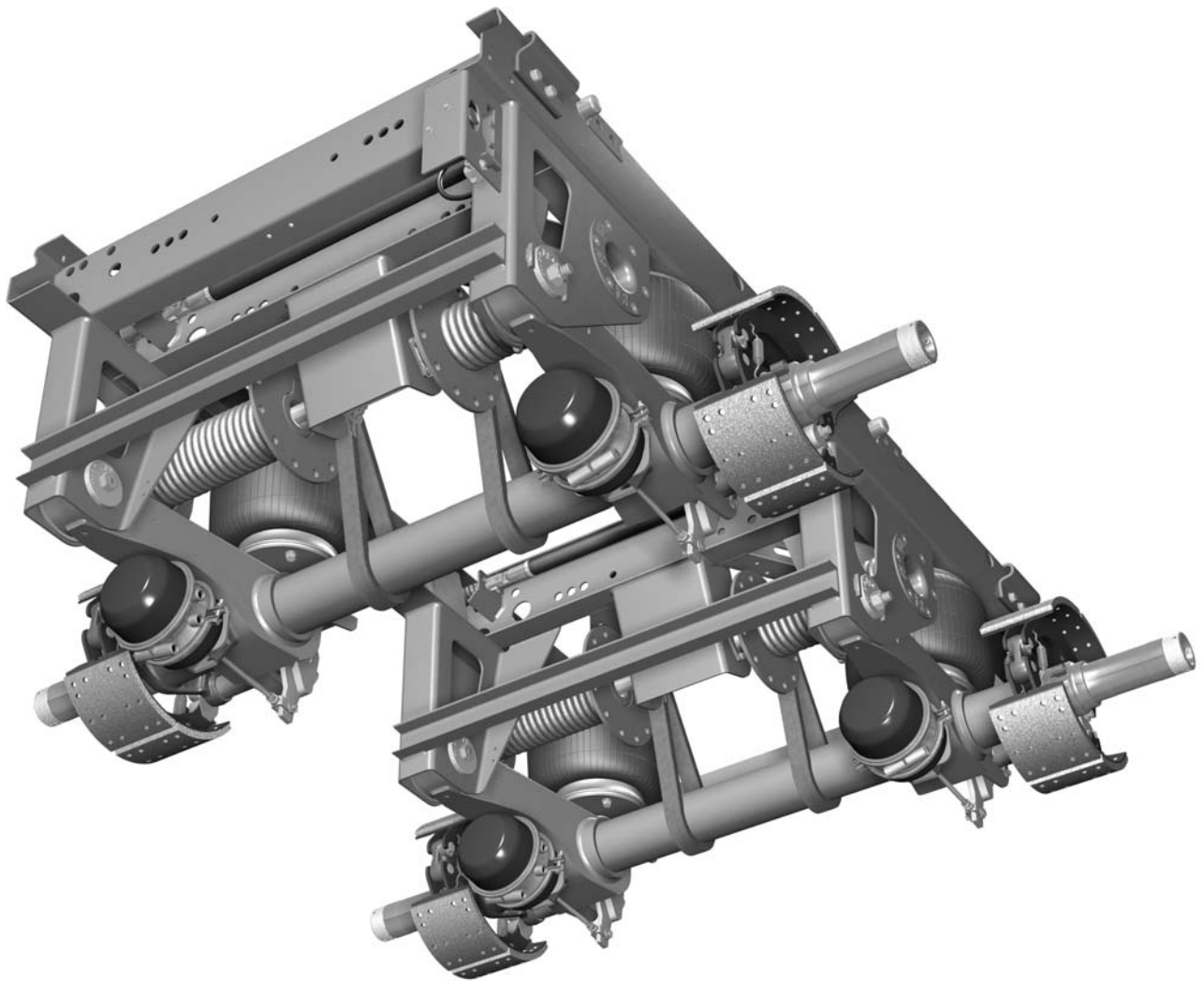



TABLE OF CONTENTS

Service Notes2

Important Safety Notice2

Explanation of Signal Words3

Preparing the Trailer for Service3

Two-piece Blocking Tool4

Air Spring Replacement4

 Removal5

 Installation6

Torsion Coil Spring Replacement7

 Releasing Coil Spring Tension8

 Removing the Coil Spring10

 Installing the Coil Spring12

 Restoring Coil Spring Tension13

Lifting Strap Replacement15

 Removal15

 Installation16

General Inspection and Maintenance18

 Visual Inspections18

 Lubrication Recommendations18

SERVICE NOTES

This publication provides maintenance procedures for VANTRAAX® HKANT 40RR and HKANT 50RR Suspension Systems. Before you begin:

- Read and understand all instructions and procedures before servicing any component.
- Read and observe all Caution and Warning statements to help avoid personal injury or property damage.
- Follow your company’s maintenance, service, installation and diagnostic practices.

Hendrickson reserves the right to make changes and improvements to its products and publications at any time. Consult the Hendrickson website (www.hendrickson-intl.com) for the latest version of this manual.

IMPORTANT SAFETY NOTICE

Proper maintenance, service and repair is important to the reliable operation of the RoadRailer suspension. The procedures recommended by Hendrickson and described in this publication are methods of performing such maintenance, service and repair.

The Warnings and Cautions should be read carefully to help prevent personal injury and to assure that proper methods are used. Improper maintenance, service or repair can cause damage to the vehicle and other property, personal injury, an unsafe operating condition and void the manufacturer’s warranty.

Carefully read, understand and follow all safety related information within this publication.



EXPLANATION OF SIGNAL WORDS

Hazard signal words (such as Danger, Warning and Caution) appear in various locations throughout this publication. Information accented by one of these signal words must be observed at all times.

Additional notes are utilized to emphasize areas of procedural importance and provide suggestions for ease of repair. The following definitions indicate the use of these signal words as they appear throughout the publication.

⚠ DANGER: Indicates immediate hazards which will result in severe personal injury or death.

⚠ WARNING: Indicates hazards or unsafe practices which could result in severe personal injury or death.

⚠ CAUTION: Indicates hazards or unsafe practices which could result in damage to machine or minor personal injury.

IMPORTANT: An operating procedure, practice or condition that is essential to emphasize.

⚠ WARNING: DO NOT MODIFY OR REWORK PARTS. DO NOT USE SUBSTITUTE PARTS OF THE SUSPENSION OR AXLE COMPONENTS. USE OF A MODIFIED PART OR REPLACEMENT PART NOT AUTHORIZED BY HENDRICKSON MAY NOT MEET HENDRICKSON'S SPECIFICATIONS AND CAN RESULT IN FAILURE OF THE PART, LOSS OF VEHICLE CONTROL AND POSSIBLE PERSONAL INJURY OR PROPERTY DAMAGE. USE ONLY HENDRICKSON AUTHORIZED REPLACEMENT PARTS. DO NOT MODIFY PARTS WITHOUT AUTHORIZATION FROM HENDRICKSON.

⚠ CAUTION: A mechanic using a service procedure or tool, which has not been recommended by Hendrickson, must first satisfy himself that neither his safety nor the vehicle's safety will be jeopardized by the method or tool selected. Individuals deviating in any manner from the provided instructions assume all risks of consequential personal injury or damage to equipment.

⚠ WARNING: ALWAYS WEAR PROPER EYE PROTECTION AND OTHER REQUIRED PERSONAL PROTECTIVE EQUIPMENT WHEN PERFORMING VEHICLE MAINTENANCE, REPAIR OR SERVICE.

PREPARING THE TRAILER FOR SERVICE

⚠ WARNING: TO PREVENT SERIOUS EYE INJURY, ALWAYS WEAR SAFETY GLASSES WHEN PERFORMING TRAILER MAINTENANCE AND SERVICE.

1. Park the trailer on a level, debris-free surface.
2. Set the trailer parking brakes.
3. To prevent the trailer from moving, chock the wheels of the axle not being raised.
4. Exhaust the air from the trailer suspension.
5. Release the trailer parking brakes.
6. Using a jack, raise the axle until the trailer wheels clear the work surface.
7. Support the raised axle with safety stands.

⚠ WARNING: DO NOT WORK UNDER A TRAILER SUPPORTED ONLY BY JACKS. JACKS CAN SLIP OR FALL OVER, RESULTING IN SERIOUS PERSONAL INJURY.

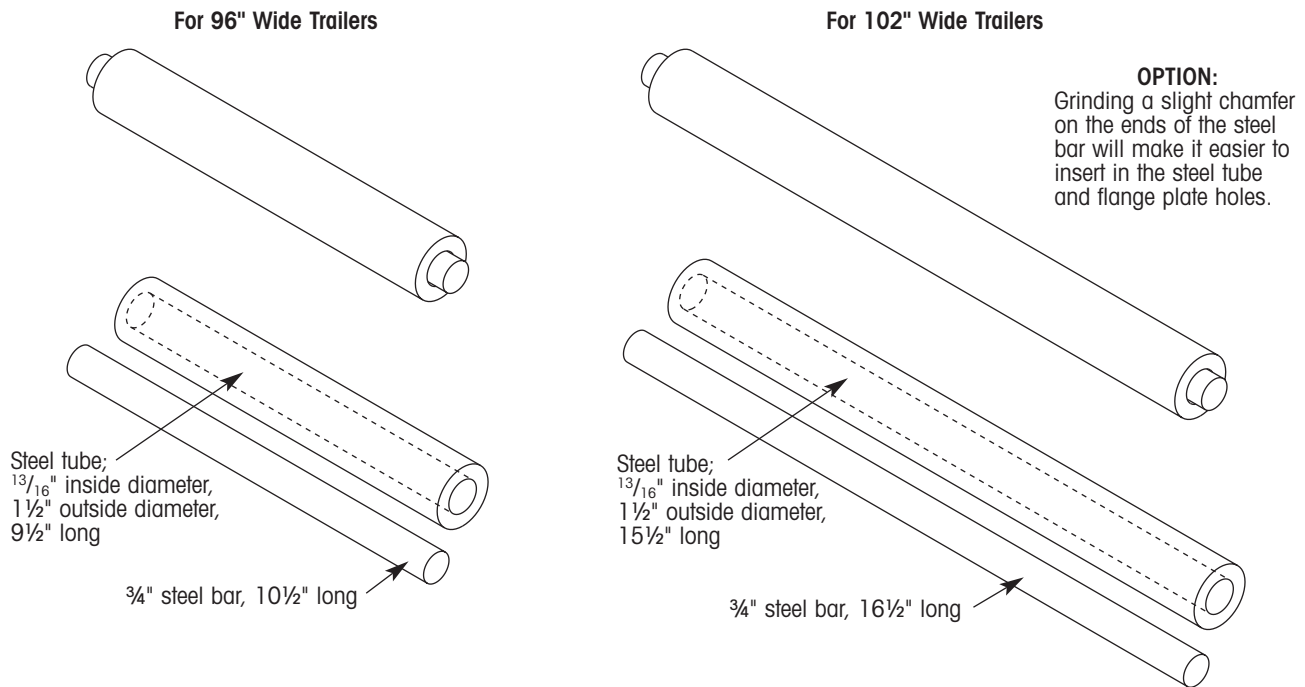

Figure 1. Two-piece blocking tool

TWO-PIECE BLOCKING TOOL

All of the service procedures described in this publication require a two-piece blocking tool. This tool is illustrated in figure 1 and can be made following the dimensions and specifications listed there.

To use the blocking tool, slide the $\frac{3}{4}$ -inch steel bar inside the steel tube. Then insert this blocking tool assembly into the proper pair of holes in the flange plate assembly as instructed in the following procedures.

The steel tube occupies the space between the flange plates and provides additional structural support for the steel bar (figure 2). When the trailer is then

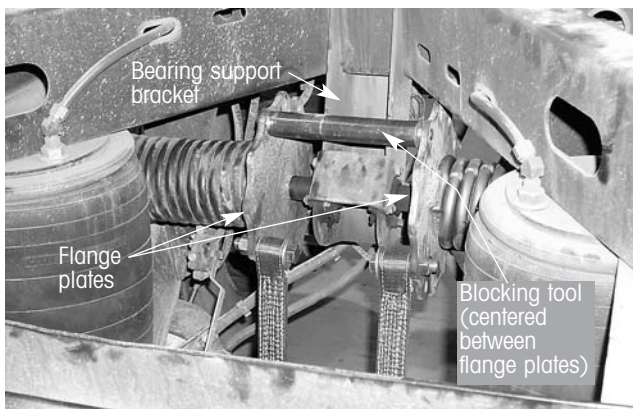

Figure 2. Example of the blocking tool in use

raised or lowered with the trailer mode valve, the suspension will travel until the steel tube contacts the rear edge of the bearing support bracket. This immobilizes the torsion coil springs and prevents any additional suspension travel, allowing you to perform the required service procedure.

AIR SPRING REPLACEMENT

Before replacing an air spring, the trailer must be supported and the torsion coil springs immobilized before the trailer air system is exhausted. The following procedures will guide you through the entire air spring replacement process.

An air supply and the two-piece blocking tool are required for air spring removal and replacement.



Figure 3. Trailer mode valve

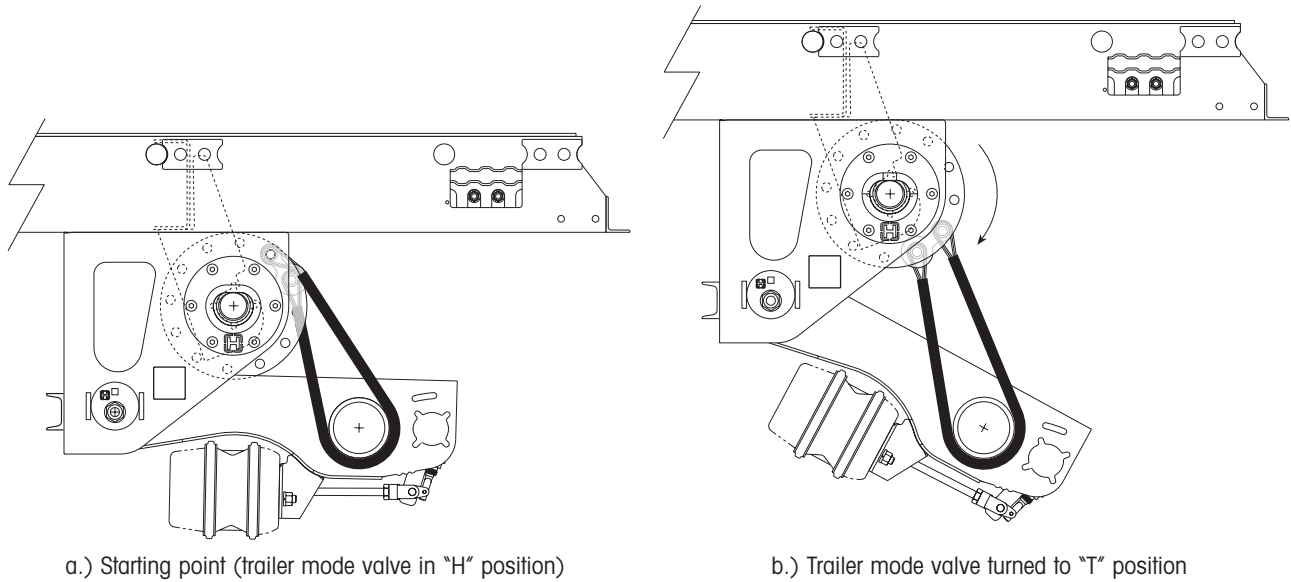

Figure 4. Beginning the air spring, torsion coil spring and lifting strap replacement procedures

REMOVAL

1. Connect the trailer to a tractor that provides an air connection through the glad hands or to a compressed air supply with approximately the same pressure as the tractor's air system.
2. Apply the trailer parking brakes and block the wheels to prevent trailer movement.
3. Turn the trailer mode valve (figure 3) to the "T" position (transfer mode). This causes the trailer to rise as shown in figure 4b.

4. Secure the trailer body in the raised position. Place jack stands, adjusted to approximately the same height as the raised trailer, under the trailer body (figure 5).

IMPORTANT: Although the illustrations show the jack stands positioned under the slider frame, they must be positioned at appropriate points under the trailer body.

5. Insert the two-piece blocking tool (figure 1) into the flange plates in front of the bearing support (figure 5). Choose the pair of flange plate holes that are as close to the bearing support as possible, yet still allow you to easily insert the blocking tool. Center the steel tube between the flange plates as shown in figure 2.

⚠ WARNING: STAY CLEAR OF THE TRAILER WHEN TURNING THE TRAILER MODE VALVE TO THE "R" POSITION IN THE FOLLOWING STEP. MOVEMENT OF SUSPENSION PARTS MAY RESULT IN PERSONAL INJURY.

6. With personnel clear of the trailer suspension, turn the trailer mode valve (figure 3) to the "R" position (rail mode). The trailer will lower slightly onto the jack stands, and the flange plate assembly will rotate counterclockwise until the blocking tool contacts the rear edge of the bearing support, preventing any additional

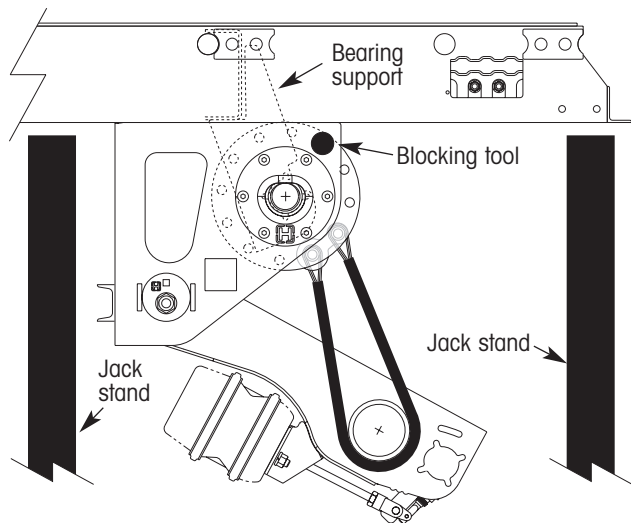

Figure 5. Place jack stands under the trailer body and insert blocking tool

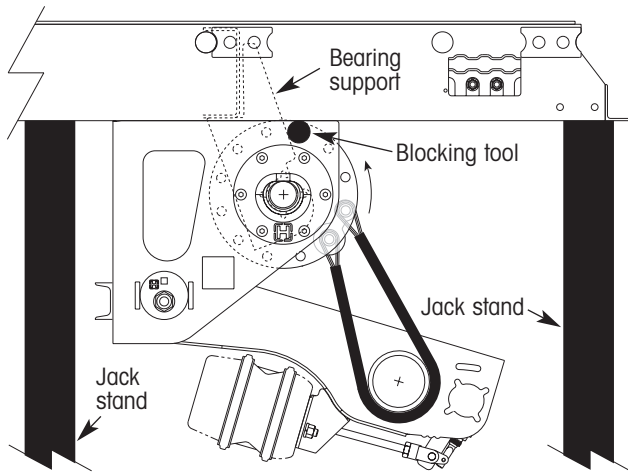

Figure 6. Turn trailer mode valve to "R" position

suspension travel (figure 6). Make sure the trailer rests securely on the jack stands.

7. Disconnect the glad hands or shop air supply.
8. Exhaust the trailer air system by opening the petcock on the bottom of the air tank.
9. Disconnect the air line from the air spring (figure 7).
10. Remove the two nuts securing the top of the air spring to the slider box subassembly (figure 8).
11. Remove the two bolts securing the bottom of the air spring to the beam assembly (figure 8) and remove the air spring.

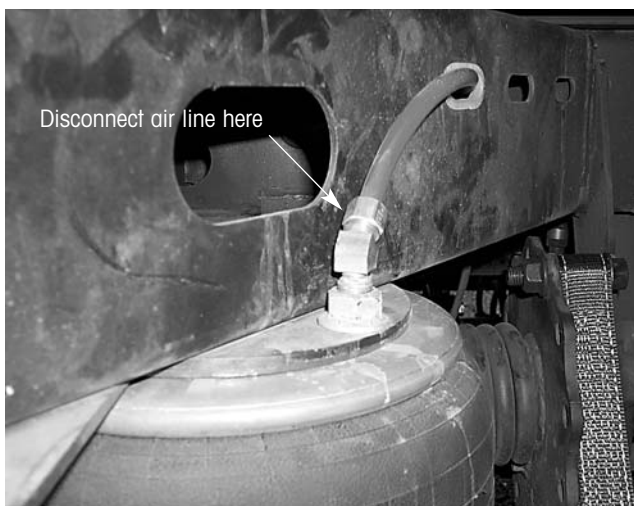

Figure 7. Air spring/air line connection

INSTALLATION

1. Position the replacement air spring on the beam assembly and install the two bottom mounting bolts. Tighten the bottom mounting bolts to a torque of 25 to 35 ft. lbs. (34 to 47 N•m).

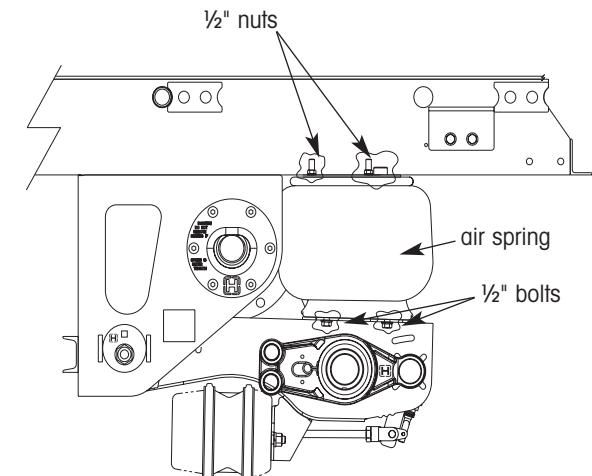
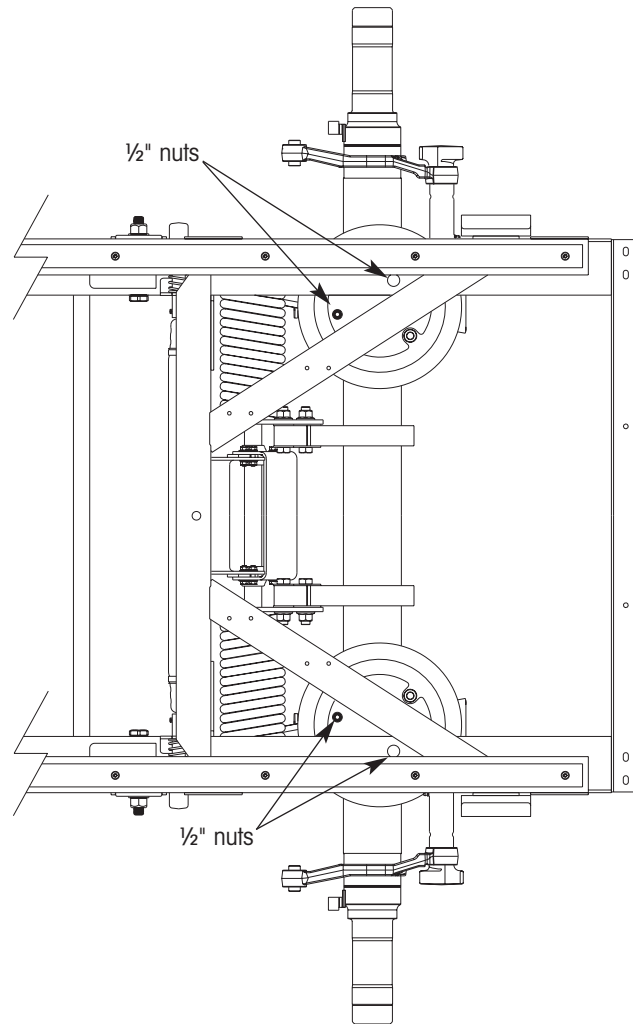

Figure 8. Air spring fastening hardware locations



2. Insert the air spring mounting studs through the holes in the slider box subassembly. Tighten the two ½-inch mounting nuts to a torque of 25 to 35 ft. lbs. (34 to 47 N•m)
3. Connect the air line to the air spring. Connection must be air tight.

IMPORTANT: DO NOT use a pipe compound or teflon tape. These materials may contaminate the air system.

4. Refill the trailer air system by reattaching the glad hands or shop air supply. If necessary, close the petcock on the bottom of the air tank. Check the new work for air leaks.
5. With personnel clear of the trailer suspension, turn the trailer mode valve (figure 3) to the "T" position (transfer mode). The trailer will rise slightly off of the jack stands, and the flange plate assembly will rotate slightly away from the rear edge of the bearing support.
6. With the jack stands still in place, remove the two-piece blocking tool from the flange plates.
7. Remove the jack stands from under the trailer.
8. With personnel clear of the trailer suspension, turn the trailer mode valve to the "H" position (highway mode). This causes the trailer to lower to its intended operating height.

TORSION COIL SPRING REPLACEMENT

⚠ WARNING: THE TORSION COIL SPRING IS LOADED WITH A HIGH DEGREE OF TENSION AND IS HELD IN THIS LOADED STATE BY THE END CAP AND THE FLANGE PLATE ASSEMBLY.

DO NOT, UNDER ANY CIRCUMSTANCES, ATTEMPT TO REMOVE THE PIVOT CONNECTION HARDWARE, THE END CAP ON THE OUTBOARD SIDE OF THE SUSPENSION OR THE LIFTING STRAP HARDWARE FROM THE FLANGE PLATE UNTIL ALL TENSION IS RELEASED FROM THE TORSION COIL SPRING (FIGURE 9). UNEXPECTED, SUDDEN AND VIOLENT MOVEMENT OF SUSPENSION PARTS COULD RESULT IN PERSONAL INJURY IF THE END CAP OR LIFTING STRAP IS REMOVED WITHOUT FIRST RELEASING ALL TENSION FROM THE TORSION COIL SPRING.

Before attempting to replace a torsion coil spring, all tension must first be released from the spring. The following procedure will guide you through the torsion releasing and coil spring replacement process.

An air supply and a two-piece blocking tool are also required for torsion coil spring replacement.

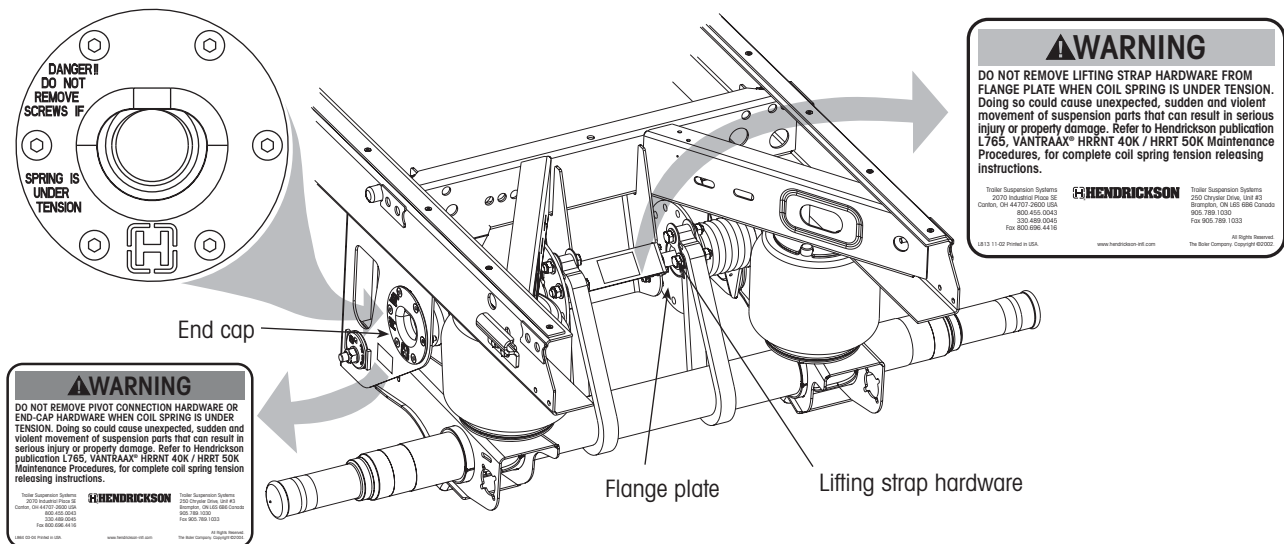

Figure 9. Do not attempt to remove end cap or lifting strap without releasing coil spring tension

RELEASING COIL SPRING TENSION

1. Connect the trailer to a tractor that provides an air connection through the glad hands, or to a compressed air supply with approximately the same pressure as the tractor's air system.
2. Apply the trailer parking brakes and block the wheels to prevent trailer movement.
3. Turn the trailer mode valve (figure 3) to the "T" position (transfer mode). This causes the trailer to rise as shown in figure 4b.
4. Secure the trailer body in the raised position. Place jack stands, adjusted to approximately the same height as the raised trailer, under the trailer body (figure 10).
5. On each flange plate, mark the original location of the $\frac{3}{4}$ -inch flange bolts and nuts. These marks will serve as a reference point in subsequent steps.

IMPORTANT: When the trailer is in the rail mode, 300 degrees of clockwise torsion spring preload is required to hold the axle in the proper position. The marks made in the previous step will help ensure that the proper preload is achieved when the new torsion spring is installed.

6. Insert the two-piece blocking tool (figure 1) into the flange plates. Choose the pair of flange plate holes that are just above the lifting straps (figure 10). Center the blocking tool between the flange plates as shown in figure 2.

⚠ WARNING: STAY CLEAR OF THE TRAILER WHEN TURNING THE TRAILER MODE VALVE TO THE "R" POSITION IN THE FOLLOWING STEP. MOVEMENT OF SUSPENSION PARTS MAY RESULT IN PERSONAL INJURY.

7. With personnel clear of the trailer suspension, turn the trailer mode valve (figure 3) to the "R" position (rail mode). The trailer will lower slightly onto the jack stands, and the flange plate assembly will rotate counterclockwise until the blocking tool contacts the rear edge of the bearing support, preventing any additional suspension travel (figure 11). Make sure the trailer rests securely on the jack stands.

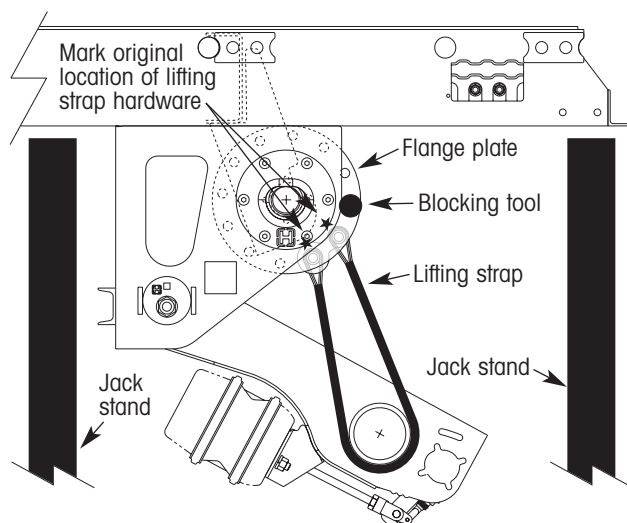

Figure 10. Place jack stands under the trailer body, mark hardware location and insert blocking tool

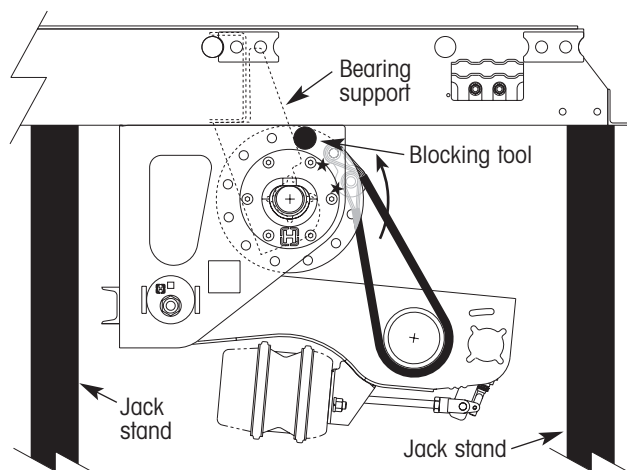

Figure 11. Turn trailer mode valve to "R" position

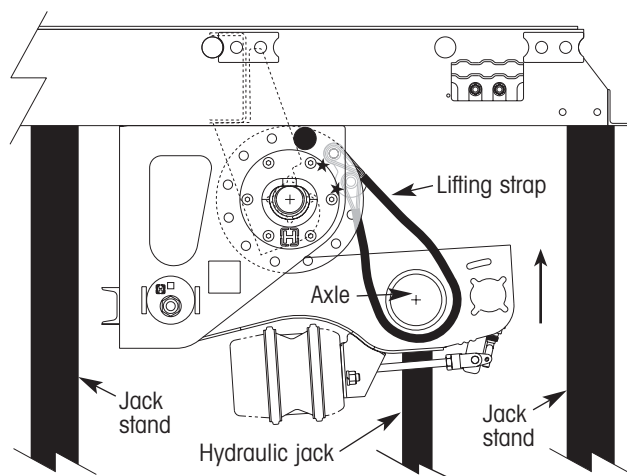

Figure 12. Raise the axle

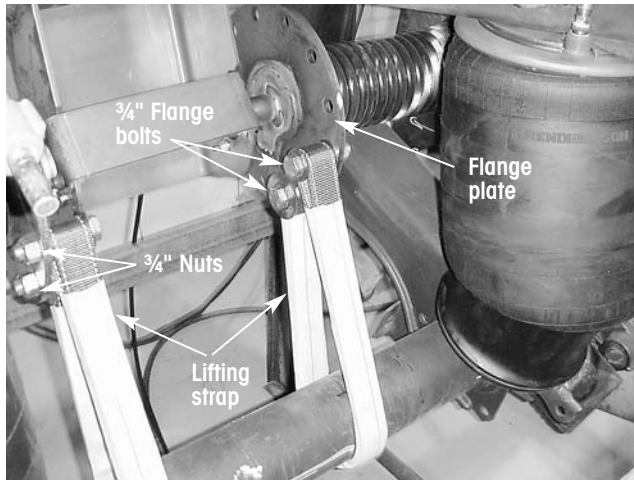

Figure 13. Remove lifting straps from flange plates

8. Place a high-travel hydraulic jack under the axle and use the jack to independently raise the axle until there is slack in the lifting straps (figure 12).
9. Remove the 3/4-inch flange bolt and nut that secures the ends of each lifting strap to each flange plate (figure 13).
10. Temporarily reattach the lifting straps in the lowest pair of flange plate holes that can be reached by the straps (figure 14).
11. Using the hydraulic jack, completely lower the axle and remove the jack from under the trailer.

⚠ WARNING: STAY CLEAR OF THE TRAILER WHEN TURNING THE TRAILER MODE VALVE TO THE "T" POSITION IN THE FOLLOWING STEP. MOVEMENT OF SUSPENSION PARTS MAY RESULT IN PERSONAL INJURY.

12. With personnel clear of the trailer suspension, turn the trailer mode valve (figure 3) to the "T" position (transfer mode). The trailer will rise slightly off of the jack stands, and the flange plate assembly will rotate clockwise, causing the blocking tool to rotate slightly away from the rear edge of the bearing support (figure 15).
13. With the jack stands still in place, remove the two-piece blocking tool from its present position in the flange plates.
14. Reinsert the two-piece blocking tool into the flange plates (figure 16). Choose the pair of

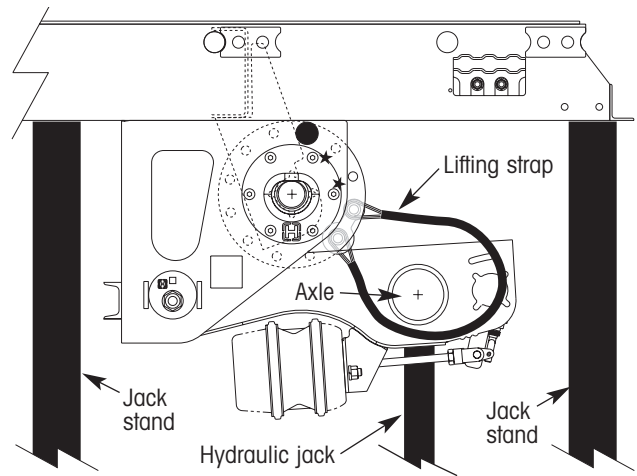

Figure 14. Reattach lifting straps in lowest pair of holes

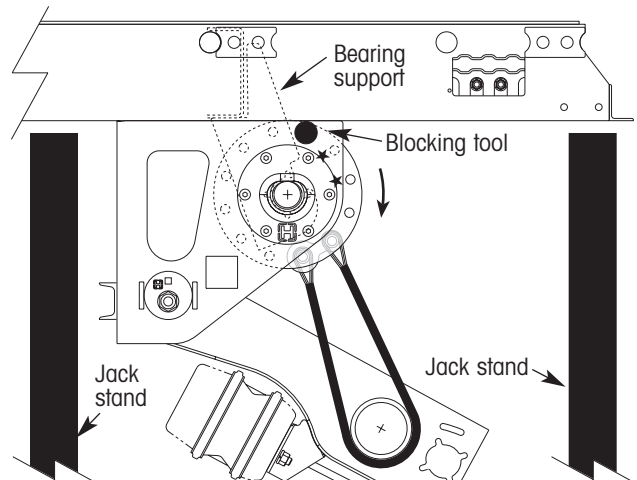

Figure 15. Lower axle, remove jack and turn trailer mode valve to "T" position

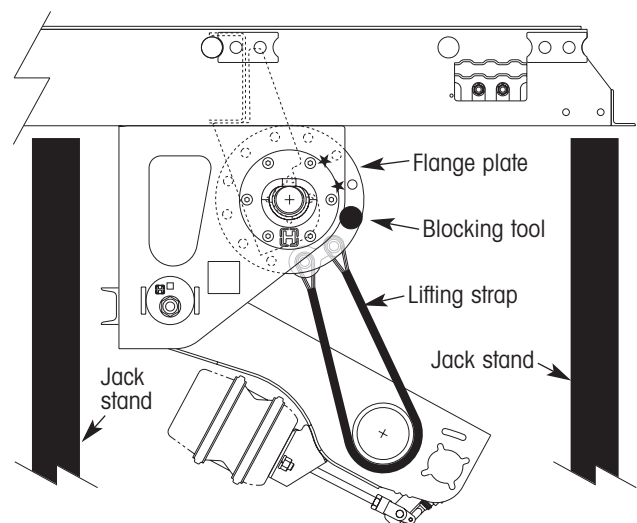

Figure 16. Remove blocking tool and reinsert above lifting straps

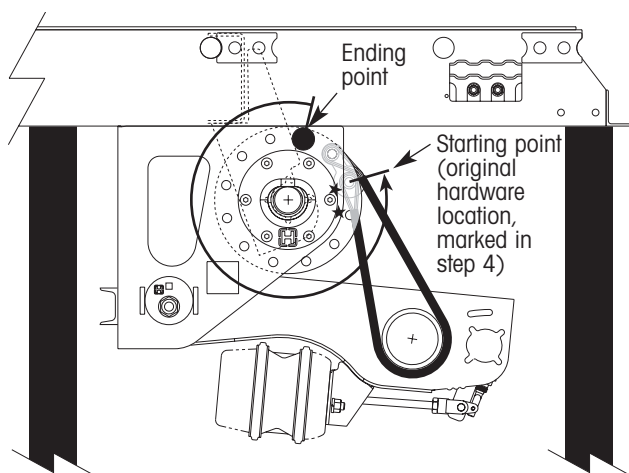

Figure 17. Torsion coil spring tension released

flange plate holes that are just above the lifting straps (figure 16). Center the blocking tool between the flange plates as shown in figure 2.

- Repeat steps seven through 14 until all tension is released from the torsion coil spring. A total of 300 degrees of flange plate assembly rotation (10 flange plate holes) is required to remove all tension from the torsion coil spring (figure 17).

REMOVING THE COIL SPRING

NOTE: There are two styles of coil spring assemblies: those with a retainer shaft and those without a retainer shaft. To identify your style of coil spring assembly, look at the center of the end caps (figure 18). If you see a nut and a D-shaped plate at the center of the end cap, you have the retainer shaft style. If there is no nut or D-plate in the center of the end cap, you have the style without the retainer shaft. The coil spring removal process varies according to coil spring assembly style. In the following procedure, follow the steps that are appropriate for your style of coil spring assembly.

- For models without the retainer shaft** With the torsion coil spring unloaded, remove the end cap fasteners and remove the end cap (figure 19).

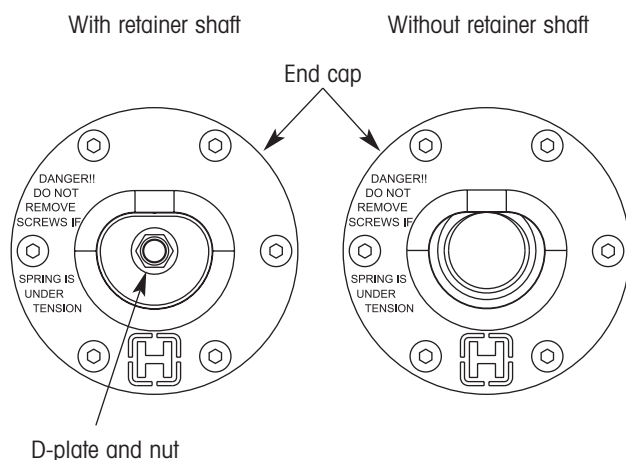

Figure 18. Coil spring assembly styles

For models equipped with the retainer shaft

With the torsion coil spring unloaded, remove the nut and D-plate from the end of the retainer shaft. Remove the end cap fasteners and remove the end cap (figure 20).

- Remove the torsion coil spring through the hole in the frame bracket.

With the torsion coil spring removed, the two shaft tubes inside the coil spring (one steel, one plastic) can be inspected. Replace these tubes only if worn or damaged.

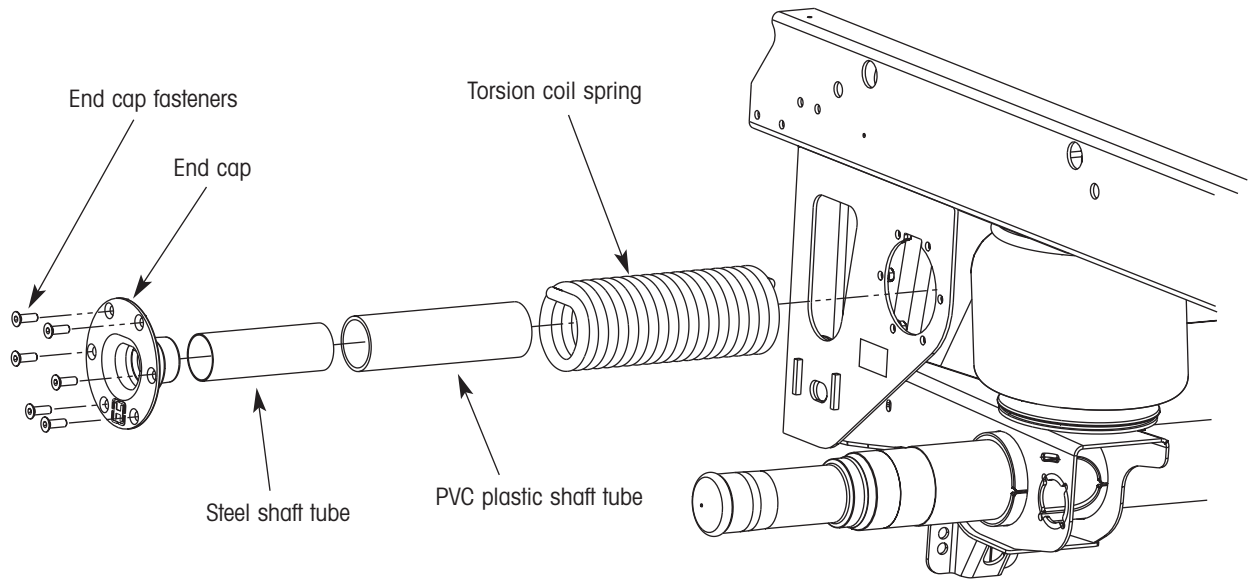

Figure 19. Removing/installing the torsion coil spring on models without the retainer shaft

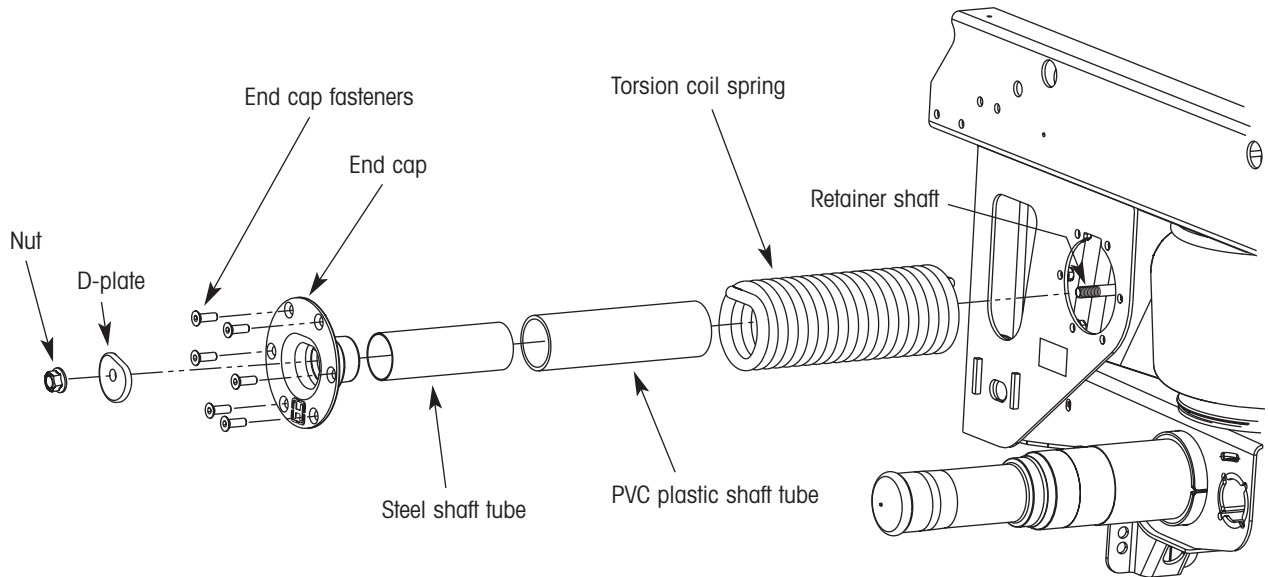

Figure 20. Removing/installing the torsion coil spring on models with the retainer shaft

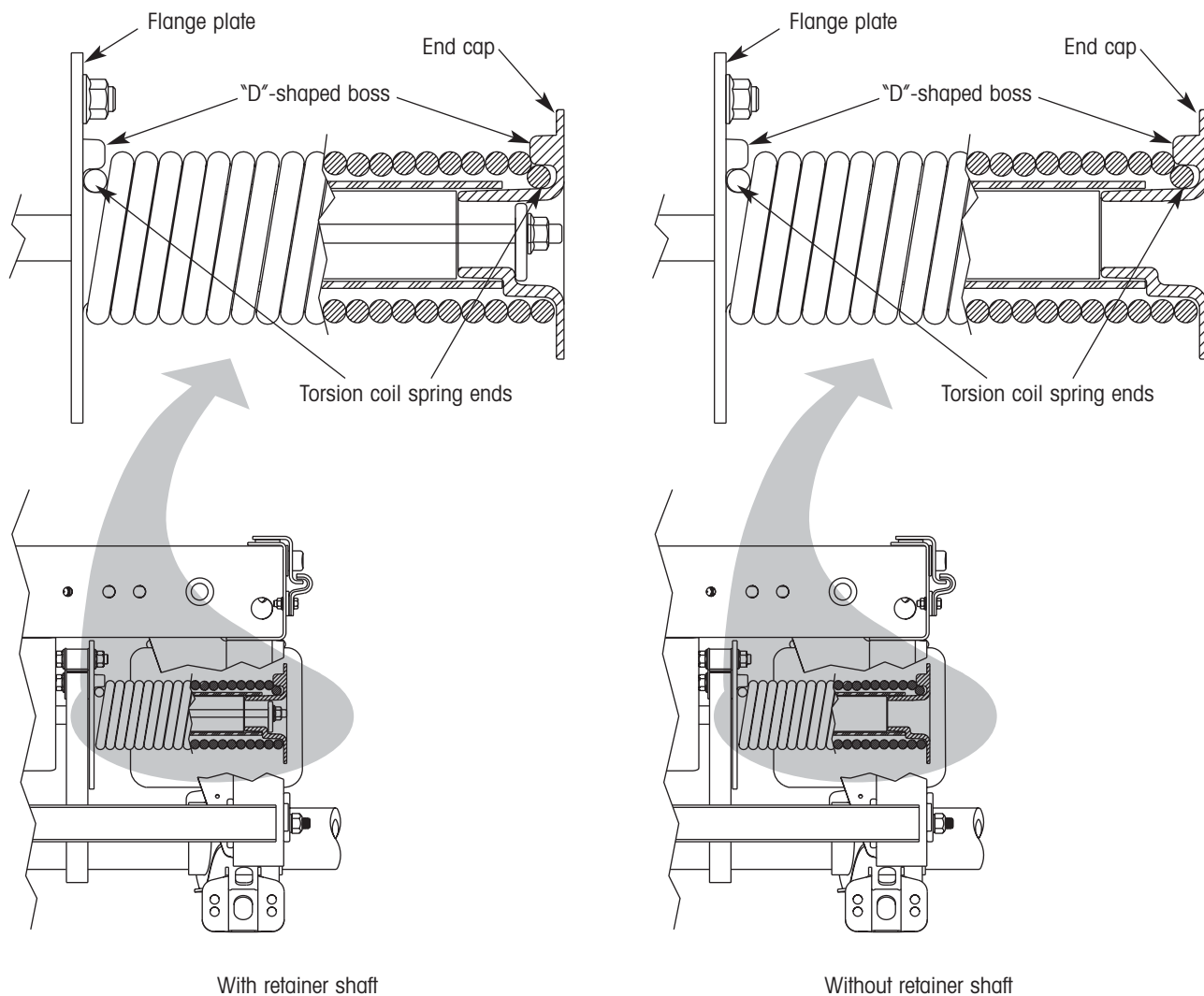

Figure 21. Torsion coil spring installation details

INSTALLING THE COIL SPRING

IMPORTANT: Torsion coil springs have left-hand (driver's side) and right-hand (curb side) orientations. Make sure the proper torsion coil spring is installed on the proper side of the suspension. To differentiate, the right hand torsion coil spring is marked with a white stripe while the left hand torsion coil spring is marked with a red stripe.

1. Insert the replacement torsion coil spring through the hole in the frame bracket and over the shaft tubes. Make sure the two tubes are installed on the shaft and the torsion coil spring slides over

the tubes. Also make sure that the torsion coil spring ends are completely engaged in the "D"-shaped boss on the end cap and flange plate (figure 21).

2. Install the end cap fasteners. Tighten to a torque of 90 to 110 ft. lbs. (122 to 149 N•m).
3. **For models equipped with the retainer shaft**
Slide the D-plate on the end of the retainer shaft. Install the torque-prevailing nut and tighten to a torque of 35 to 40 ft. lbs. (47 to 54 N•m).



RESTORING COIL SPRING TENSION

1. Turn the trailer mode valve (figure 3) to the "T" position (transfer mode). This causes the trailer to rise (figure 22).
2. With the jack stands still in place, remove the two-piece blocking tool from its present position in the flange plates.
3. Reinsert the two-piece blocking tool into the flange plates. Choose the pair of flange plate holes that are closest to the bearing support (figure 22). Center the blocking tool between the flange plates as shown in figure 2.

⚠ WARNING: STAY CLEAR OF THE TRAILER WHEN TURNING THE TRAILER MODE VALVE TO THE "R" POSITION IN THE FOLLOWING STEP. MOVEMENT OF SUSPENSION PARTS MAY RESULT IN PERSONAL INJURY.

4. With personnel clear of the trailer suspension, turn the trailer mode valve (figure 3) to the "R" position (rail mode). The trailer will lower slightly onto the jack stands, and the flange plate assembly will briefly rotate counterclockwise until the blocking tool contacts the rear edge of the bearing support, preventing any additional suspension travel (figure 23). Make sure the trailer rests securely on the jack stands.
5. Place a high-travel hydraulic jack under the axle and use the jack to independently raise the axle to the top of its travel (figure 24).
6. Remove the 3/4-inch flange bolt and nut that secures the ends of each lifting strap to each flange plate (figure 13).

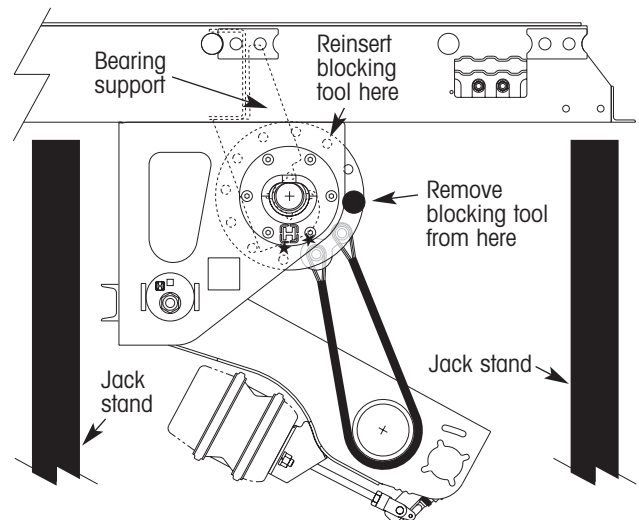

Figure 22. Turn trailer mode valve to "T" position, remove and reinsert blocking tool

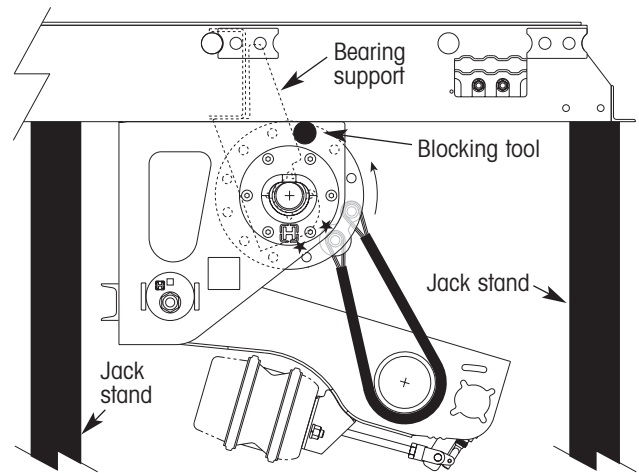

Figure 23. Turn trailer mode valve to "R" position

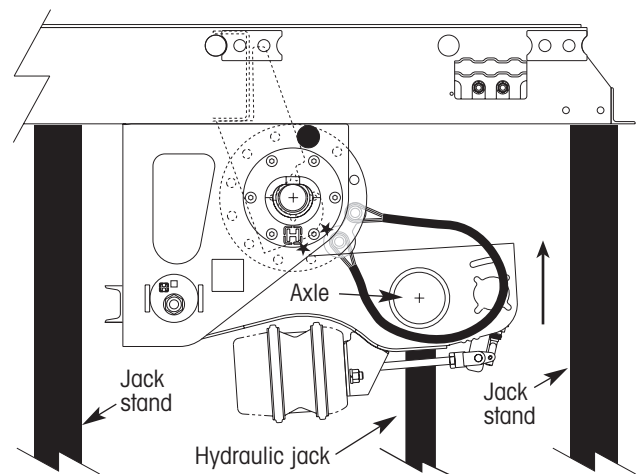

Figure 24. Raise the axle

7. Temporarily reattach the lifting straps in the highest pair of flange plate holes that can be reached by the straps (figure 25).
8. Using the hydraulic jack, completely lower the axle and remove the jack from under the trailer.

⚠ WARNING: STAY CLEAR OF THE TRAILER WHEN TURNING THE TRAILER MODE VALVE TO THE "T" POSITION IN THE FOLLOWING STEP. MOVEMENT OF SUSPENSION PARTS MAY RESULT IN PERSONAL INJURY.

9. With personnel clear of the trailer suspension, turn the trailer mode valve (figure 3) to the "T" position (transfer mode). The trailer will rise slightly off of the jack stands, and the flange plate assembly will rotate clockwise, causing the blocking tool to rotate away from the rear edge of the bearing support (figure 26).
10. With the jack stands still in place, remove the two-piece blocking tool from its present position in the flange plates.
11. Reinsert the two-piece blocking tool into the flange plates. Choose the pair of flange plate holes that are closest to the bearing support (figure 26). Center the blocking tool between the flange plates as shown in figure 2.
12. Repeat steps four through 11 until tension is restored to the torsion coil spring. A total of 300 degrees of flange plate assembly rotation (10 flange plate holes) is required to restore tension to the torsion coil spring. Make sure the $\frac{3}{4}$ -inch flange bolts and nuts are in the same holes originally marked in step five of the *Releasing Coil Spring Tension* procedure.

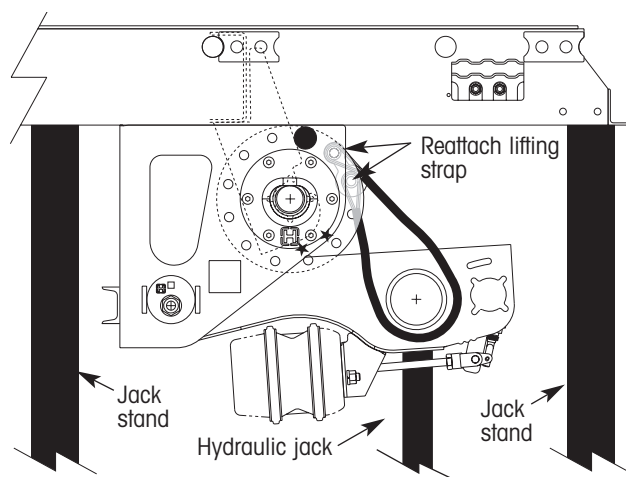

Figure 25. Reattach lifting straps in highest pair of holes

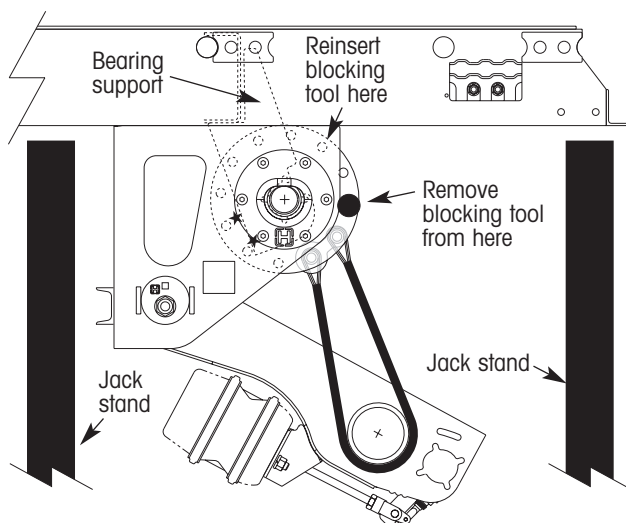

Figure 26. Turn trailer mode valve to "T" position, remove and reinsert blocking tool



NOTE: Use the GO / NO-GO gauge (part number S-28504) to ensure the flange bolts and lifting straps are properly installed (figure 27).

- 13. Turn the trailer mode valve to the "T" position to lift the trailer and remove the two-piece blocking tool.

⚠ WARNING: STAY CLEAR OF THE TRAILER WHEN TURNING THE TRAILER MODE VALVE TO THE "R" POSITION IN THE FOLLOWING STEP. MOVEMENT OF SUSPENSION PARTS MAY RESULT IN PERSONAL INJURY.

When the lifting straps are properly installed, the entire gauge fits over the topmost lifting strap connection:

When the lifting straps are **not** properly installed, the gauge will not engage the lifting strap connection.

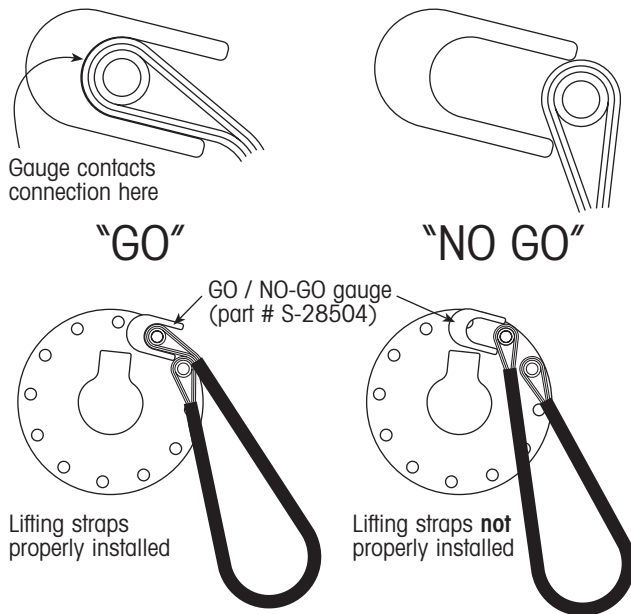

Figure 27. Checking for proper installation

- 14. Check the axle lift height. With personnel clear of the trailer suspension and the jack stands still in place, turn the trailer mode valve to the "R" position (rail mode). The trailer will lower slightly onto the jack stands and the torsion coil springs will cause the flange plate assembly to rotate counterclockwise, lifting the axle and wheels off of the ground. Ensure that the axle lifts to a 13-inch position (from the centerline of the axle to the bottom of the subframe) as shown in figure 28.

If the axle does not lift to a 13-inch position, the torsion coil spring requires more tension. Refer to step 12 above for complete coil spring tension restoring instructions.

- 15. Turn the trailer mode valve to the "T" position (transfer mode) to lift the trailer and remove the jack stands.
- 16. Turn the trailer mode valve to the "H" position (highway mode). This causes the trailer to lower to its intended operating height.

LIFTING STRAP REPLACEMENT

Before replacing a lifting strap, the trailer must be supported and the torsion coil springs immobilized. The following procedure will guide you through the entire lifting strap replacement process. An air supply and the two-piece blocking tool are also required for lifting strap replacement.

REMOVAL

- 1. Connect the trailer to a tractor that provides an air connection through the glad hands, or to a compressed air supply with approximately the same pressure as the tractor's air system.

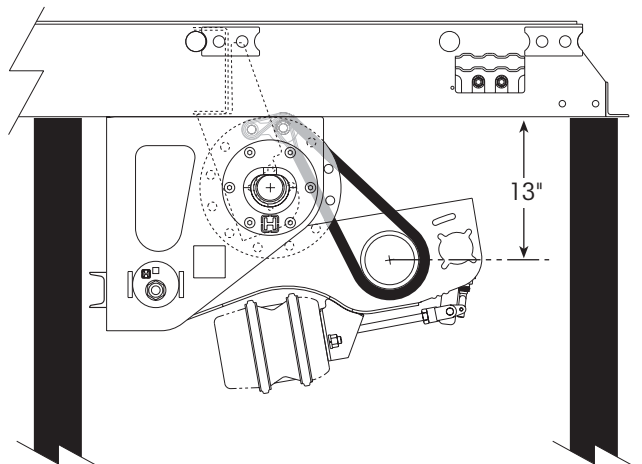

Figure 28. Checking axle lift height



2. Apply the trailer parking brakes and block the wheels to prevent trailer movement.
3. Turn the trailer mode valve (figure 3) to the "T" position (transfer mode). This causes the trailer to rise as shown in figure 4b.
4. Secure the trailer body in the raised position. Place jack stands, adjusted to approximately the same height as the raised trailer, under the trailer body (figure 29).
5. Insert the two-piece blocking tool (figure 1) into the flange plates in front of the bearing support (figure 29). Choose the pair of flange plate holes that are as close to the bearing support as possible, yet still allow you to easily insert the blocking tool. Center the steel tube between the flange plates as shown in figure 2.

⚠ WARNING: STAY CLEAR OF THE TRAILER WHEN TURNING THE TRAILER MODE VALVE TO THE "R" POSITION IN THE FOLLOWING STEP. MOVEMENT OF SUSPENSION PARTS MAY RESULT IN PERSONAL INJURY.

6. With personnel clear of the trailer suspension, turn the trailer mode valve (figure 3) to the "R" position (rail mode). The trailer will lower slightly onto the jack stands, and the flange plate assembly will rotate counterclockwise until the blocking tool contacts the rear edge of the

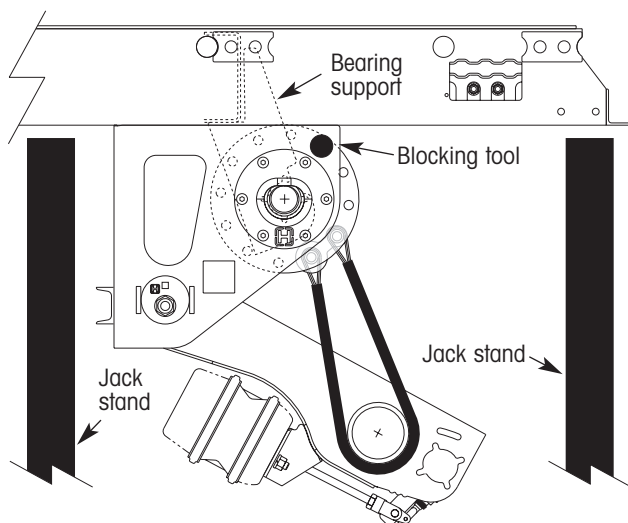

Figure 29. Place jack stands under the trailer body and insert blocking tool

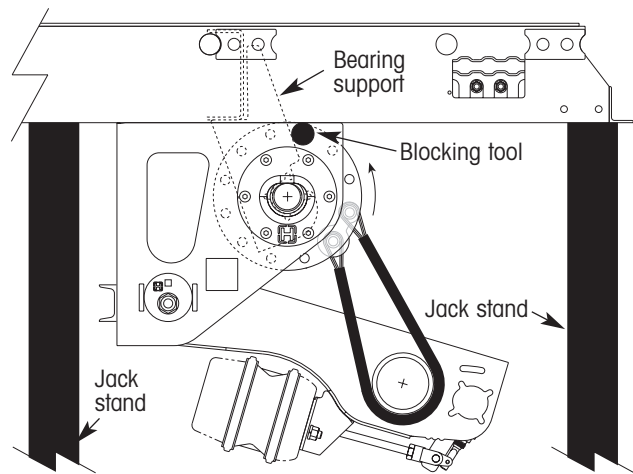

Figure 30. Turn trailer mode valve to "R" position

bearing support, preventing any additional suspension travel (figure 30). Make sure the trailer rests securely on the jack stands.

7. Disconnect the glad hands or shop air supply.
8. Exhaust the trailer air system by opening the petcock on the bottom of the air tank.
9. On the flange plate, mark the location of the 3/4-inch flange bolts and nuts. This mark will serve as a reference point for installing the new lifting link.
10. If necessary, place a hydraulic jack under the axle and use the jack to raise the axle just enough to create slack in the lifting straps.
11. Remove and discard the 3/4-inch flange bolts and nuts that secure the lifting strap to the flange plate. New hardware will be used to secure the replacement lifting strap in place.

INSTALLATION

1. Make sure the steel sleeve is in place in both lifting strap ends (figure 31). Loop the replacement strap around the axle.
2. Using the new 3/4-inch flange bolts and nuts from the lifting strap service kit, attach each end of the replacement strap to the flange plate in the holes

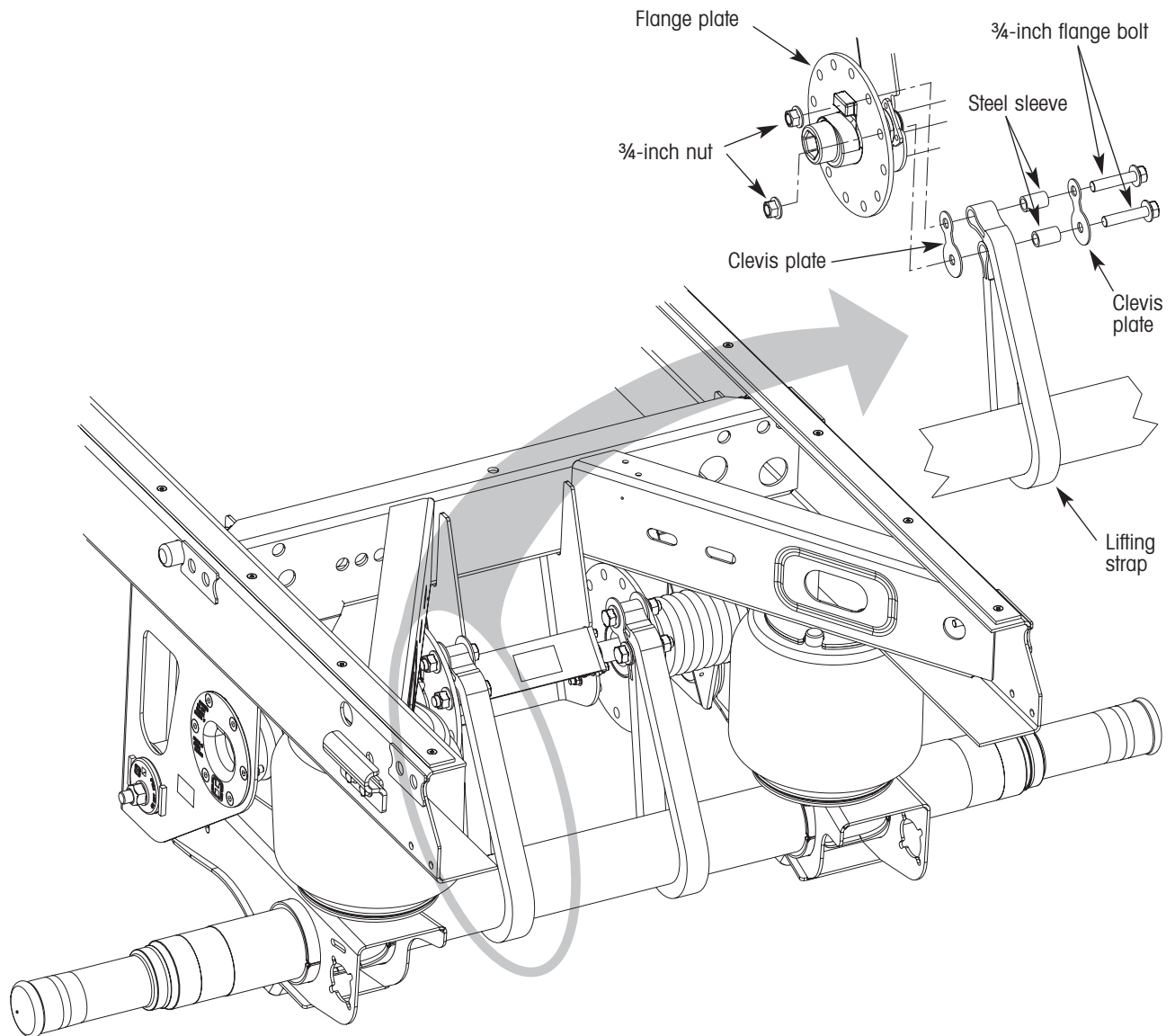

Figure 31. Removing/installing the lifting strap

marked in step nine of the removal procedure. Tighten the 3/4-inch flange nuts and bolts to a torque of 210 to 235 ft. lbs. (285 to 319 N•m).

NOTE: Use the GO / NO-GO gauge (part number S-28504) to ensure the flange bolts and lifting straps are properly installed (figure 27).

3. Using the hydraulic jack, completely lower the axle and remove the jack from under the trailer.

4. Refill the trailer air system by reattaching the glad hands or shop air supply. If necessary, close the petcock on the bottom of the air tank.

5. With personnel clear of the trailer suspension, turn the trailer mode valve (figure 3) to the "T" position (transfer mode). The trailer will rise slightly off of the jack stands, and the flange plate assembly will rotate slightly away from the rear edge of the bearing support.



6. With the jack stands still in place, remove the two-piece blocking tool from the flange plates.
7. Remove the jack stands from under the trailer.
8. With personnel clear of the trailer suspension, turn the trailer mode valve to the "H" position (highway mode). This causes the trailer to lower to its intended operating height.

GENERAL INSPECTION AND MAINTENANCE

VISUAL INSPECTIONS

In addition to the normal VANTRAAX® inspections (refer to Hendrickson publication L578, *System Maintenance*), these additional visual inspections should be performed for all VANTRAAX® HRRNT 40K / HRRT 50K models:

<p><u>Inspect:</u> Lifting straps</p> <p>Torsion coil springs</p> <p>Air springs</p>	<p><u>Evaluate:</u> overall condition, over-extension</p> <p>overall condition</p> <p>overall condition, leaks</p>
--	--

LUBRICATION RECOMMENDATIONS

In addition to the normal VANTRAAX lubrication requirements (cam tube, wheel-ends, etc.), the shaft bearing assemblies (figure 32) also require periodic lubrication. Lubricate these bearings every 7,500 miles with #2EP NLGI chassis lube.

If the trailer is being used as a storage vessel or is otherwise not in daily service, shaft bearing lubrication is only required four times a year.

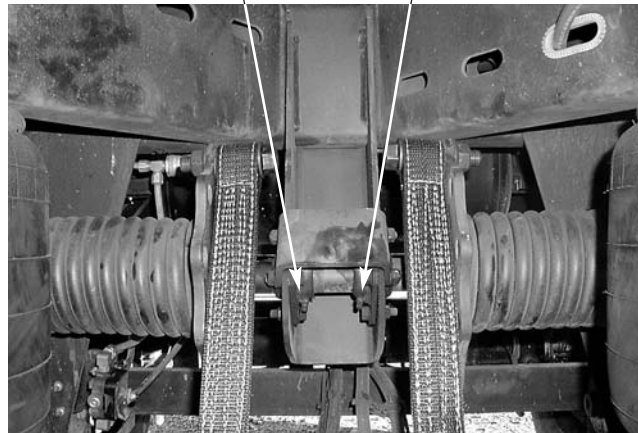
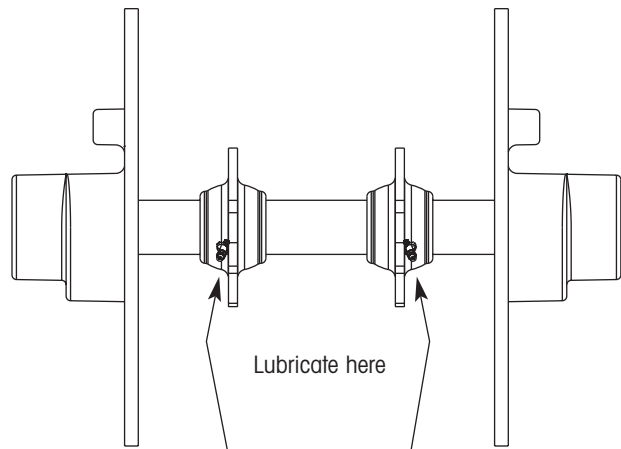

Figure 32. Shaft bearing lubrication points





Information contained in this literature was accurate at the time of publication. Product changes may have been made after the copyright date that are not reflected.

Trailer Suspension Systems
2070 Industrial Place SE
Canton, OH 44707-2600 USA

866.RIDEAIR (866.743.3247)
330.489.0045
Fax 800.696.4416

www.hendrickson-intl.com

Trailer Suspension Systems
250 Chrysler Drive, Unit #3
Brampton, ON L6S 6B6 Canada

905.789.1030
Fax 905.789.1033

The Boler Company.
Copyright © 2003
All Rights Reserved