



H TECHNICAL PROCEDURE

**HN/HNT-400/460
Truck & Trailer Suspension
In Production: 11/88-9/96**

SUBJECT: Service Instructions

LIT NO: 17730-198

DATE: April 1998

REVISION: B

CONTENTS

ITEM	SUBJECT	PAGE
1	Introduction	2
2	Important Safety Notice	2
3	HN/HNT-400/460 Series Description	3
4	Alignment	4
5	Tandem Cross Member Recommendation	4
6	Axle Bracket Welding Recommendation	4
7	Preventive Maintenance	6
	Beam End Connections	6
	Bolster Springs	9
	Torque Rods and Transverse Rods	10
	Beam Center Cross Tube	11
	Rebound Control Assemblies	11
8	Component Replacement	12
	Beam End Bushings and Beam End Adapters	12
	Bar Pin Beam End Bushings	17
	Bolster Springs	23
	Torque Rod and Transverse Rod Bushings	23
	Beam Center Cross Tube	24
	Beam Center Bushings	25
	Jounce Stop and Rebound Control Assemblies	25
	Shock Absorbers	26
9	HNT Suspension for Trailer Applications	27
	'A' Frame Torque Rod Service Removal	27
	HNT Bushing Replacement	27
10	Tightening Torque Specification Chart	28

Subject 1 INTRODUCTION

This publication is to acquaint and assist maintenance personnel in preventive maintenance and rebuild of the HN-400/460 suspension. HN Series are available for truck/tractor applications and are identified as HN. For trailer applications the suspension is designated HNT.

Use only genuine Hendrickson parts for servicing these suspensions. Most Hendrickson parts can be identified by the  Hendrickson trademark.

Note the date of this publication. Hendrickson Suspension periodically revises and updates this publication. If this copy is more than one year old, contact Hendrickson Suspension to determine if a later copy is available.

Subject 2 IMPORTANT SAFETY NOTICE

Proper service and repair is important to the safe and reliable operation of the tandem suspension. The service procedures recommended by Hendrickson and described in this technical publication are effective methods of performing maintenance.

There are various warnings and cautions that should be read carefully to minimize the risk of personal injury and to assure that proper methods are used. Improper servicing may damage the vehicle or render it unsafe in operation.

WARNING

HENDRICKSON SUSPENSION REMINDS USERS TO ADHERE TO THE PUBLISHED CAPACITY RATINGS FOR THE SUSPENSIONS. ADD-ON AXLE ATTACHMENTS AND OTHER LOAD TRANSFERRING DEVICES CAN INCREASE THE SUSPENSION LOAD ABOVE THE RATED AND APPROVED CAPACITIES WHICH COULD RESULT IN FAILURE AND LOSS OF VEHICLE CONTROL POSSIBLY CAUSING PERSONAL INJURY OR PROPERTY DAMAGE.

DO NOT MODIFY OR REWORK PARTS. DO NOT USE SUBSTITUTE PARTS. USE OF A MODIFIED OR SUBSTITUTE PART IS NOT RECOMMENDED BECAUSE THE PART MAY NOT MEET HENDRICKSON'S SPECIFICATIONS, WHICH COULD RESULT IN FAILURE OF THE PART, LOSS OF VEHICLE CONTROL, AND POSSIBLE PERSONAL INJURY OR PROPERTY DAMAGE.

DO NOT USE A CUTTING TORCH TO REMOVE ANY ATTACHING FASTENERS. DO NOT USE A CUTTING TORCH TO REMOVE THE EQUALIZING BEAMS FROM THE AXLES OR TO REMOVE THE BUSHINGS FROM THE BEAM CENTERS OR ENDS. WELDING, TORCHING OR ATTACHING MATERIAL TO THE EQUALIZING BEAMS MUST NEVER BE PERFORMED. THE USE OF HEAT ON SUSPENSION COMPONENTS WILL ADVERSELY AFFECT THE STRENGTH OF THESE PARTS. A COMPONENT DAMAGED IN THIS MANNER MAY RESULT IN THE LOSS OF VEHICLE CONTROL AND POSSIBLE PERSONAL INJURY OR PROPERTY DAMAGE.

A MECHANIC USING A SERVICE PROCEDURE OR TOOL WHICH HAS NOT BEEN RECOMMENDED BY HENDRICKSON MUST FIRST SATISFY HIMSELF THAT NEITHER HIS SAFETY NOR THE VEHICLE'S SAFETY WILL BE JEOPARDIZED BY THE METHOD OR TOOL SELECTED. INDIVIDUALS DEVIATING IN ANY MANNER FROM THE INSTRUCTIONS PROVIDED ASSUME ALL RISKS OF CONSEQUENTIAL PERSONAL INJURY OR DAMAGE TO EQUIPMENT INVOLVED.

Subject 3
DESCRIPTION

The HN-400/460 suspension, as shown in Figure 1 for truck/tractor applications, uses four solid rubber bolster springs operating in shear and compression to cushion road shocks. The springs are mounted between the equalizing beams and the saddles. Effective operation relies on the characteristic of rubber that as it is compressed it becomes progressively stiffer, thereby providing similar ride characteristics empty or loaded. Four shock absorbers add dampening.

Figure 1
HN-400/460

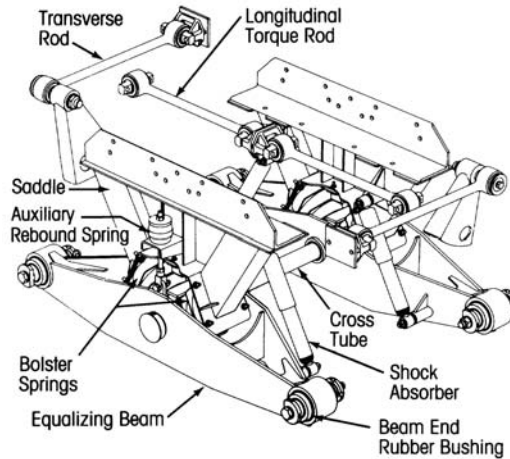

The bolster springs together with rubber bushings in the equalizing beam ends accommodate the articulation of the axles without friction or metal-to-metal contact.

Upper longitudinal torque rods absorb axle braking and accelerating torques. Transverse rods provide positive lateral positioning of the axles and control axle walk-out during cornering. All rods use rubber bushings.

The HN suspension incorporates transverse rod axle brackets and torque rods for vehicle stability. If these components are disconnected or are non-functional the vehicle should not be operated.

Rebound control as well as enhanced roll stability is accomplished through the use of two auxiliary spring assemblies.

The beam center cross tube connects the two equalizing beams through nylon bushings in the beams and adds stability to the suspension.

The Hendrickson suspension is also suitable for applications such as transfer, semi-dump and tank trailers. The trailer suspension has been identified as the HNT Series as shown in Figure 2.

Figure 2
HNT Series

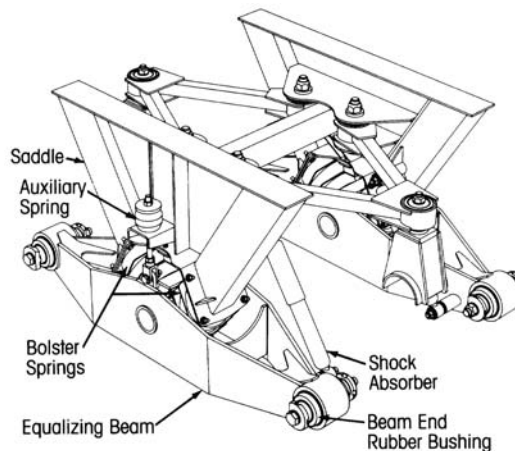

**Subject 4
ALIGNMENT**

The primary control for alignment is the location of the saddles on the frame rail by the vehicle manufacturer, and the location of the axle brackets as installed by the axle manufacturer.

Hendrickson has two styles of beam end connections. The most common connection uses rubber bushings with beam end adapters. The other style is a Bar Pin bushing discussed later in this publication which has an alignment feature. If you have the Bar Pin style end connection refer to Technical Publication 17730-213 for detailed alignment instructions.

**Subject 5
TANDEM CROSS MEMBER
RECOMMENDATION**

Hendrickson recommends that a tandem cross member and frame liner assembly be installed in the chassis frame, as shown in Figure 3.

Figure 3

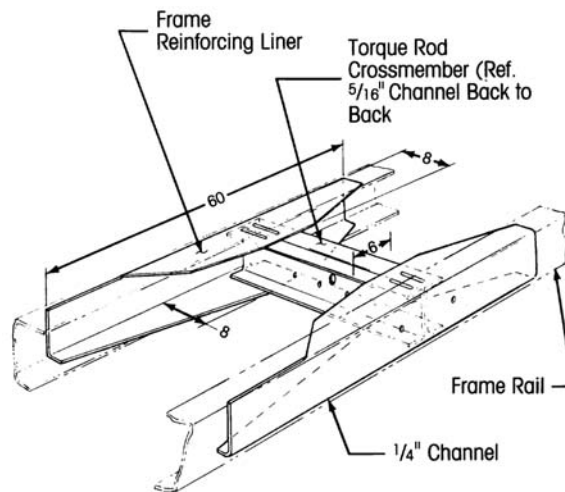

**Subject 6
AXLE BRACKET WELDING
RECOMMENDATION**

The axle brackets on drive axles are furnished and welded into position on the axle by the axle manufacturer.

The axle brackets on trailer axles may be furnished and welded into position on the axle by the axle manufacturer or by the trailer manufacturer. Hendrickson furnishes axle brackets for trailer axles only.

When installing trailer axle brackets, the base of each axle bracket must fit flush and tight against the axle. The center lines of the left hand and right hand beam hanger brackets must be in absolute alignment and parallel with each other. They must also be parallel to the horizontal center line of the axle. The beam hanger brackets must be equally located from the center line of the axle and chassis. Any error in beam hanger bracket positions will result in misalignment of the suspension.

The torque rod axle bracket must be located on the vertical center line of the axle.

The following procedure is recommended when welding axle brackets to the axle as shown in Figure 4.

1. Axle and axle bracket must be at room temperature (50° F minimum).
2. Axle and axle bracket must be free from dirt, scale, paint, grease or any foreign substance which will adversely affect weld integrity.
3. Base of brackets must fit snugly against the axle.

4. Properly position axle brackets on axle to assure axle alignment.
5. The axle brackets may be tack welded to the axle provided the tack welds do not exceed 1" in length. Final welding must consume all tack welds.
6. Final weld size shall be $\frac{3}{8}$ " minimum fillet. Minimum weld length on beam hangers shall be per Figure 4.
7. All welds must be accomplished in the flat, horizontal position.
8. Clean weld between passes and after final pass.
9. Refer to Figure 4 for the direction and sequence of final weld. Minimize staffs and stops during welding. Do not lay two (2) consecutive passes at the same location.
10. Recommended (or equivalent) consumables:
 - E70XX Oven-dried, low hydrogen electrode per AWS A5.1 or A5.5
 - E70S-X Wire per AWS A5.18
 - Electrode/wire diameter, voltage and amperage settings and gas mixture per manufacturer recommendations.

To insure compatibility between the suspension axle brackets and the axle, approval by the axle manufacturer is required.

Square Axle Procedure — 2 Welds $3\frac{3}{4}$ " long per side. Do not carry welding past corner of bracket flange. See below for weld sequence and direction.

Figure 4

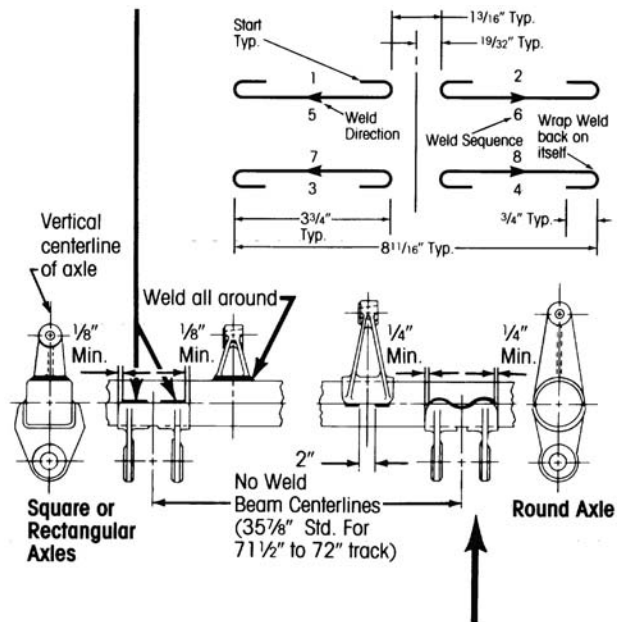

Round Axle Procedure — Weld 8" long both sides. Do not carry welding past corner of bracket flange. See below for weld sequence and direction.

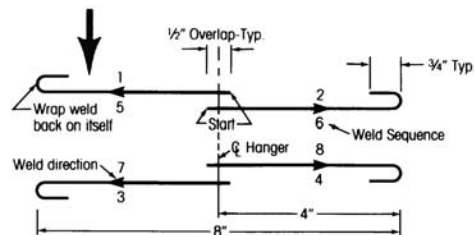

Subject 7
PREVENTIVE
MAINTENANCE

Proper preventive maintenance programs will help control repair costs and down-time. This is important for safe and reliable operation. All new equipment should be given on initial pre-service inspection. This includes checking all the tightening torques of the Hendrickson HN Tandem Suspension as specified by the truck manufacturer, and as listed in the tightening torque specification chart at the end of this publication. We also recommend that all the tightening torques be checked with a torque wrench at least once a year.

BEAM END CONNECTIONS

The beam end connections for the HN suspension are available in two styles. Shown in Figure 5 is a three-piece design with a 1" diameter Grade 8 through bolt. The two end adapters pilot into the bushing inner metal, and into the intermediate tube, giving full support to the bushing. The tightening torque for the through bolt locknut for the HN-400 3/4" locknut (Figure 5) is 210 to 240 and for the HN-460 1" locknut (Figure 6) is 445 to 495 foot pounds.

Figure 5
HN-400

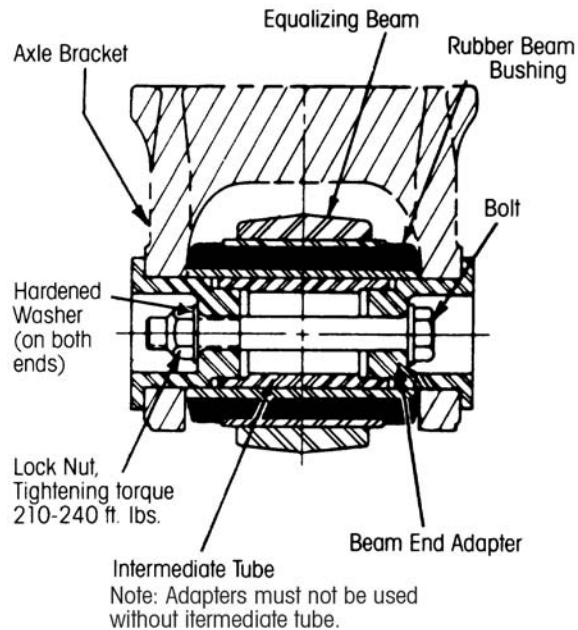
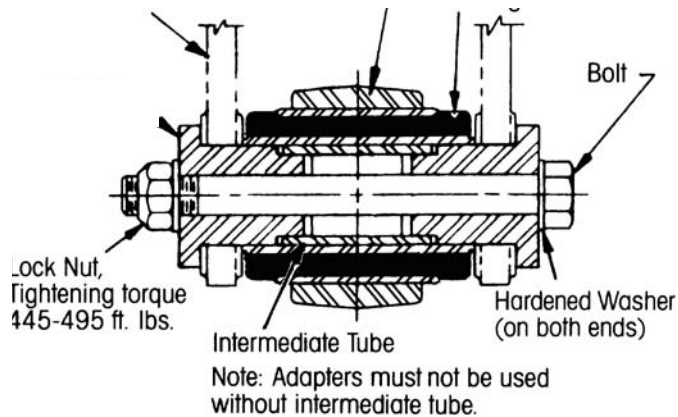

Figure 6
HN-460



The beam end adapter assemblies require that the fasteners be kept tight to maintain the clamp of the rubber bushing inner metals to the inside surface of the axle bracket legs. All bushing motion is accommodated by rubber deflection and there should be no motion between mating metal surfaces.

The flange of the adapters is cut off for assembly clearance with the axle housing bowl. The flat must be positioned in the vertical position as shown in Figure 7 when the through bolt locknut is tightened.

Figure 7

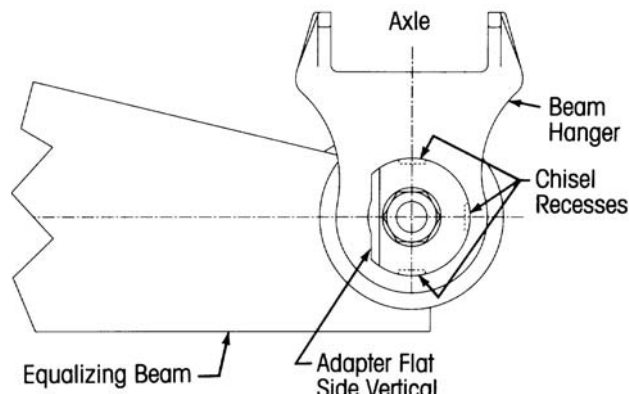

The beam end adapters require that the through bolt locknut torque be checked with a torque wrench before a new or repaired vehicle is placed in service. Check the torque again after 1,000 miles of off-highway or severe service, or 10,000 miles of on-highway service. **Do not exceed torque specifications.**

The other beam end connection is a bar pin style bushing. This bushing uses a beam hanger design as shown in Figures 8 and 9 or both truck and trailer suspensions, and is a rubber bushing assembly consisting of a rubber insert, an outer metal tube, and an inner casting. It is fastened to the axle by two (2) one inch diameter, Grade 8 bolts and two (2) one inch, Grade C locknuts. One inch hardened, flat washers are located under both the bolt heads and the locknuts. The bolts are installed from end

Figure 8
34013-088
Bar Pin Bushing Kit with
Alignment Shims

Figure 9
34013-087
Bar Pin Bushing Kit without
Alignment Shims

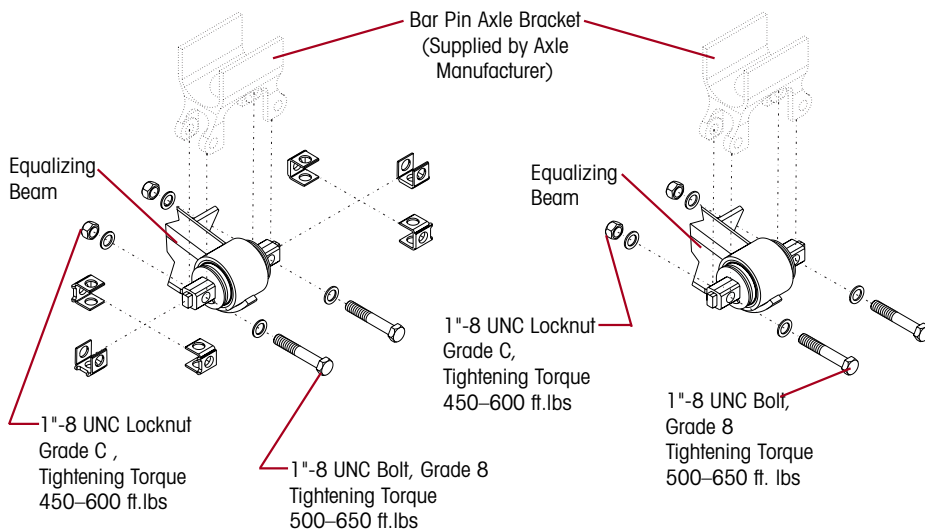

Figure 10
Beam/Beam End Bushing with
three-piece adapter.

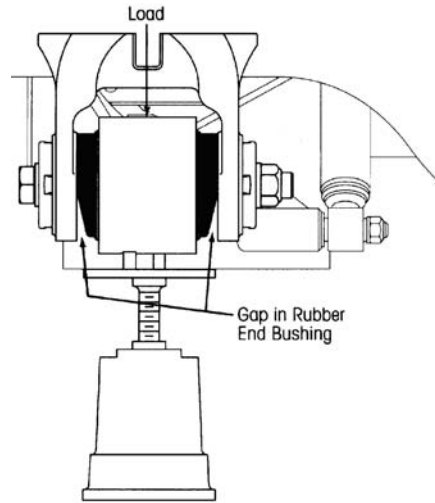
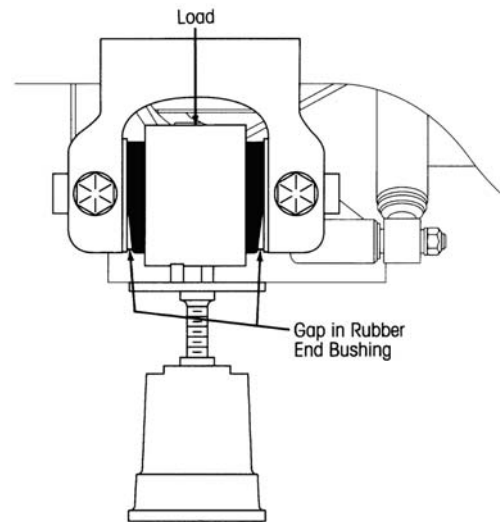

Figure 11
Beam with Bar Pin Style Bushing.



of the beam toward the center line and are positioned parallel to the vehicle longitudinal axis making removal and assembly easy. The tightening torque for the Bar Pin connection with 1" bolts to be torqued at the head of the bolt is 500 to 650 foot pounds. The tightening torque at the 1" locknut is 450 to 600 foot pounds.

This beam end connection requires that the fasteners be kept tight to maintain the clamp of the axle bracket legs to the bushing inner metals. All bushing motion is accommodated by rubber deflection. The torque should be checked when a new or repaired vehicle is placed in service and again after 1,000 miles of off-highway service or 10,000 miles of on-highway service.

When it is necessary to have a vehicle in the shop for major repair work or preventive maintenance, place a jack under each beam end, as shown in Figure 10, and 11 to check for movement of the rubber end bushing inner metal. This movement cannot be eliminated by tightening the locknut due to excessive wear to mating parts and increasing clearances. If movement is noted, do not operate the vehicle. Replace the rubber end bushing and all connecting parts.

Periodic visual inspection by the driver and service personnel is also recommended. Look for the beam being lower in the beam hanger, or distorted or frayed rubber. Off-highway and severe service operating conditions require more frequent inspections than on-highway service operations.

The gap on each side of the visible rubber at the lower end of the end bushing is normal and is not an indication to replace the bushing. Because all rubber end bushings are in compression, with the load bearing on the top side, the lower side of the rubber is slightly relieved, allowing the rubber to move inward, and a gap appears.

Figure 12

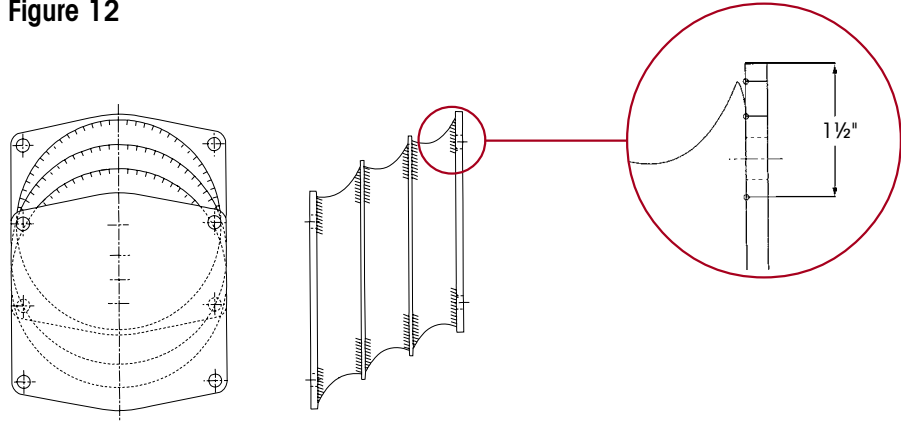

BOLSTER SPRINGS

Inspect all four bolster springs. Wide variations in operating conditions make it difficult to fix definite limits for the suitability of bolster springs. The following points are for guidance and are intended to assist persons examining the springs in reaching their decision to replace them. Hendrickson recommends that both bolster springs on one beam be replaced even if only one shows wear. When the bolster springs are replaced on one side only, you may find that the vehicle leans slightly. The new bolster springs will tend to settle to some degree, and return the vehicle to its original condition.

Bent or cracked metal parts: overhanging edges of metal plates are occasionally bent or burred through mishandling in service. Providing the rubber is not trapped, and there are no sharp metal edges in contact with the free surface of the rubber, the damage is acceptable.

Creases: formed by folding of the rubber surface under load should be ignored. These appear as strips on the surface, polished by wear or covered with tacky rubber.

Oil and Grease Contamination: due to the type of application on which bolster springs are used, oil and grease contamination is not usually a problem. Certain softening of the rubber surface can be accepted, but springs should be rejected if any swelling due to contamination increases the rubber diameter to $\frac{1}{4}$ " beyond its normal position. It is important that the slight change in shape due to permanent set is not mistaken for oil and grease contamination.

Cuts or Splits: of over 3" in length and of an average depth of 1" should be considered as possible points of failure. A certain amount of gradual breakup of the rubber surface is normal. The most probable areas of damage are shown in Figure 12 as "//////".

Bonding Defects: showing separation of the rubber from the bonded metal surface to a depth of approximately $1\frac{1}{2}$ " is acceptable. See Figure 12. An unloaded bolster spring may be inspected by measuring at points indicated "//////" in Figure 12. If depth is $1\frac{1}{2}$ " or more, bolster spring should be replaced. Feather edge of $\frac{3}{8}$ " may be ignored when inspecting.

TORQUE RODS AND TRANSVERSE RODS

Figure 13. The length of the torque rods is determined by the vehicle manufacturer for optimum drive line angles. The torque rods control these angles and also absorb driving and braking forces. The length of the transverse rods is determined by the vehicle manufacturer to center the axles under the frame. The transverse rods control axle walk-out during cornering. The mounting brackets at the axle ends of both rods are furnished and welded into position on the axle housings by the axle manufacturer.

Figure 13

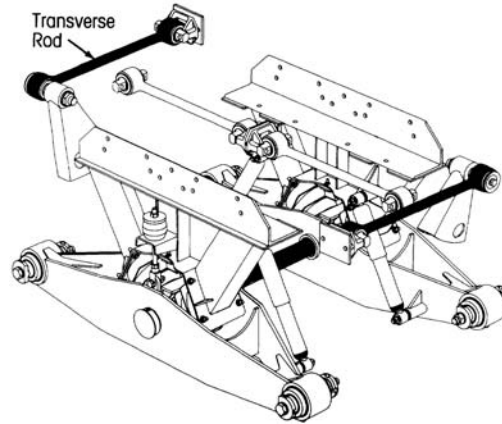

Both types of rods may have attaching ends designated "straddle mount" or "tapered stud" as shown in Figure 14.

Straddle mount rod end attaching fasteners are furnished by the vehicle manufacturer. It is important that the tightening torque of the locknuts be checked during preventive maintenance service. Follow the vehicle manufacturer's specifications for tightening torque values.

NOTE

Hendrickson Suspension recommends Grade 8 bolts and Grade C locknuts be used for all straddle mount torque rod and straddle mount transverse rod attachments.

Tapered stud rod locknuts also should be checked. The tightening torque is 175 to 225 foot pounds.

Figure 14

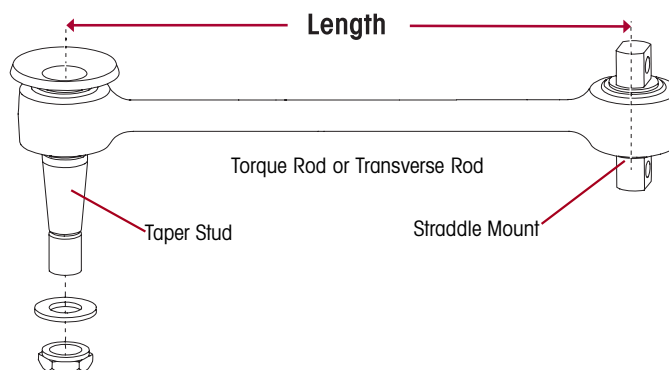

Inspect all rods for looseness, or torn or shredded rubber. A lever check can be made with a long pry bar placed under each rod end and pressure applied. Longitudinal torque rods can be checked by slowly rocking an empty vehicle with power and the brakes applied, while a mechanic visually checks the action at both ends.

Whether the rod ends are straddle mount or tapered stud, they can be renewed by pressing out the worn end, and installing a cartridge type replacement. A two-piece rod is also available to cut and weld to the desired length (see Bulletin 45745-020).

BEAM CENTER CROSS TUBE

The beam center cross tube connects the two equalizing beams through the nylon beam center bushings. Figure 12. The cross tube has clearance to float in the nylon bushings. The length of the cross tube will allow side float of approximately 2¼". For this reason, the cross tube may appear polished at each end where it enters into the center bushings. This is normal. A cross tube very seldom requires replacement, usually only when it has been bent, possibly due to hitting on unseen object. A bent cross tube will cause misalignment of the axles, and must be replaced immediately to eliminate abnormal tire wear.

REBOUND CONTROL ASSEMBLIES

The adjustable rebound bumper assembly prevents the overextension of the bolster springs during vehicle operation, see Figure 15.

NOTE

For proper suspension operation, this assembly must be adjusted after the body is installed and prior to being put in service.

Figure 15

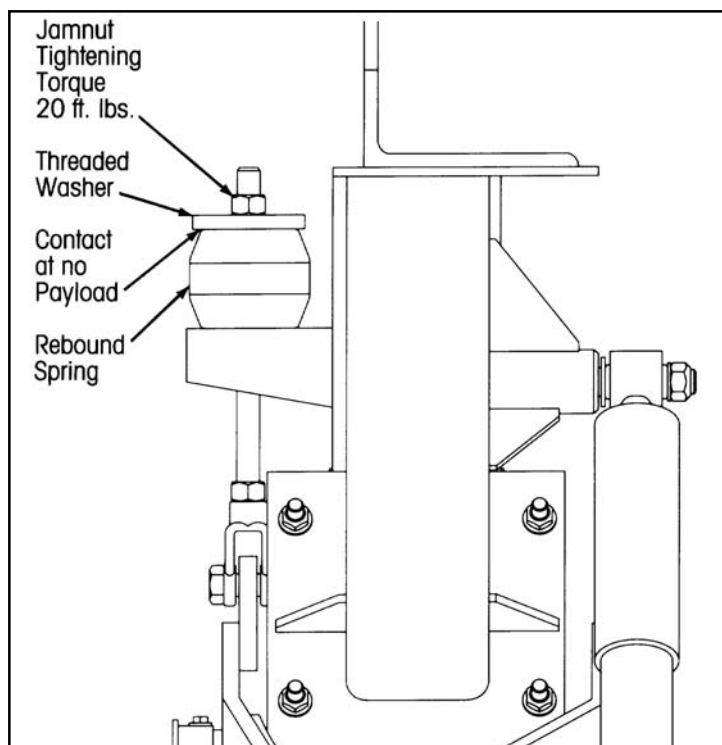

Subject 8
COMPONENT
REPLACEMENT

BEAM END BUSHINGS AND BEAM END ADAPTERS

Apply a penetrating oil to the beam end connections and support the end of the beam. Removal of the beam end adapters can be done with an air hammer chisel as shown in Figure 16. Begin by removing the through bolt locknut, washers and grade 8 bolt. The adapters have three chisel entry recesses located in the flanges as shown in Figure 17. With the air hammer chisel, turn the adapter to locate the recesses for entry of the chisel as shown in Figure 18. If the adapter does not turn, use a hammer to rap the outside of the axle bracket legs around the adapter area and repeat with the air hammer chisel. When the adapter has space between the axle bracket and the adapter flange, use a bent chisel as shown in Figure 16 to wedge and force the adapter out.

CAUTION

SUPPORT THE END OF THE BEAM AS IT MAY DROP WHEN THE OTHER ADAPTER IS REMOVED. AFTER REMOVING ADAPTERS, DISCARD THEM, DO NOT REUSE THEM.

WARNING

WHEN REMOVING AND INSTALLING BUSHINGS IN EQUALIZING BEAMS, FOLLOW THE PROCEDURES OUTLINED IN THIS PUBLICATION. DO NOT USE A CUTTING TORCH TO REMOVE THE BUSHING OUTER METALS PRESSED IN THE BEAM BORES. WELDING, TORCHING OR ATTACHING MATERIAL TO THE EQUALIZING BEAM MUST NEVER BE PERFORMED. THE USE OF HEAT ADVERSELY AFFECTS THE STRENGTH OF THE BEAMS.

Figure 16
Air Hammer Chisel

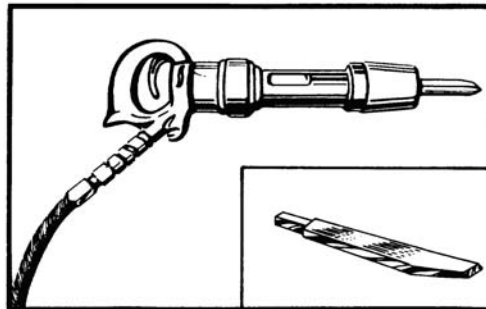

Figure 17

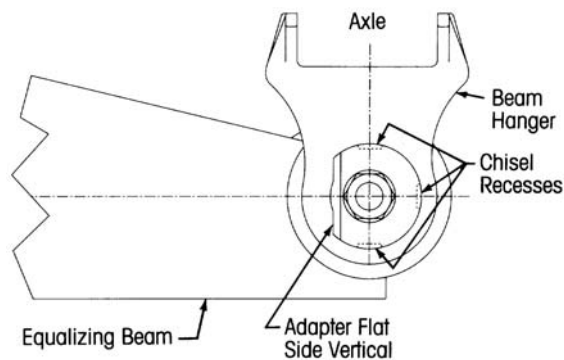
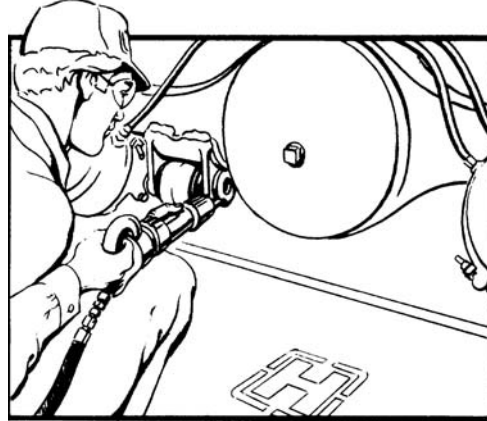

Figure 18
Air chisel removal
of Adapters



After removing equalizing beam bushings, thoroughly inspect each beam bore. If torch undercutting is found from previous rebushing, replace with a new equalizing beam. Do not take the responsibility for possible road failure by rebushing a beam in this condition.

The rubber end bushings can be removed with Owatonna Tool Company's tooling, or with shop made tools.

If Owatonna Tool Company's tooling is to be used, follow their instructions. Each end bushing can be replaced individually without removing the equalizing beams from the chassis.

If shop made tools are to be used, the equalizing beams must be removed from the chassis.

Begin by cuffing the protruding rubber of one side of the beam end bushing as shown in Figure 19. This permits the pushing tool to contact the outer metal of the bushing. A piece of 4 1/4" O.D. by 4" long steel tubing will remove the bushing. Use a shop press with a capacity of at least 80 tons. Place the equalizing beam in the shop press with the beam end bore squarely supported on the press bed for safety and to avoid bending the equalizing beam. Center the pushing tool on the outer metal of the bushing and push the bushing out of the beam bore.

Figure 19
Cutting off rubber on one
side for pushing tool
clearance

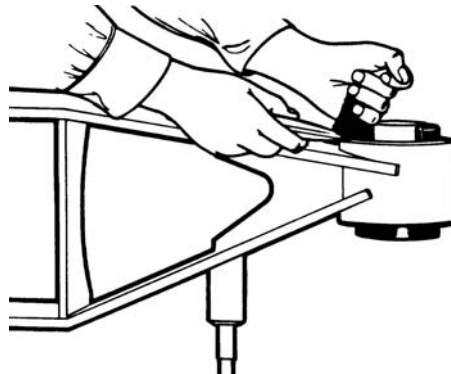

The outer metals of some Hendrickson rubber bushings are covered with a phosphate coating which acts as a rust preventive. This coating must be removed with an emery cloth before installation. Also apply a coating of white lead or grease to the cleaned outer metals of the bushings and to the beam bores to facilitate pressing the new bushings into the beam bores.

Rubber end bushings can be installed with Owatonna Tool Company's tooling, or with shop made tools. If Owatonna Tool Company's tooling is to be used, follow their instructions.

If shop made tooling is to be used, a piece of 4½" I.D. by 4" long steel tubing will install the end bushings. A sheave puller as shown in Figure 20 is required to compress the rubber to allow contact with the bushing outer metal.

Place the equalizing beam in the shop press with the beam end bore squarely supported on the bed for safety, and to avoid bending the equalizing beam. Press in the new bushings as shown in Figure 20. All end bushings must be centered within the beam end hub.

Figure 20

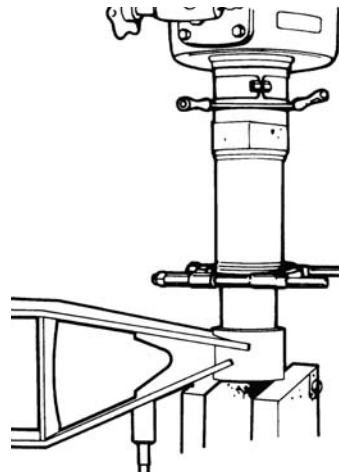
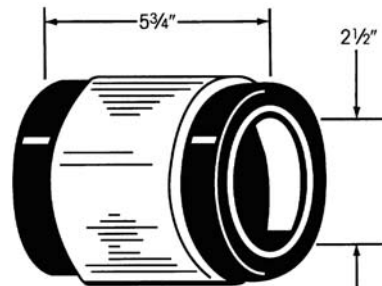

Figure 21
Part No. 45900-000
I.D. 2½"
Overall Length 5¾"



Prior to assembly, Axle Bracket Cleaning Inspection is required. Inspect the 2½" diameter holes in each of the axle bracket legs as shown in Figure 22. Remove any burrs or material left there by the old adapters. Use a new adapter as a gauge for fit, being sure it enters the holes from the outside of each bracket leg. The dimension between the inside surfaces of the axle bracket legs for Beam End Adapter style, as shown in Figure 22 as Dimension "A", must be 5.760/5.770" for the HN-400/460 series suspensions with

5 $\frac{3}{4}$ " long end bushings. Apply an anti-seize compound to all mating metal surfaces of the axle brackets, end bushing, and connecting hardware. This will aid in the assembly as well as prevent possible corrosion making future disassembly difficult. Position the intermediate tube into the end bushing inner metal.

Figure 22

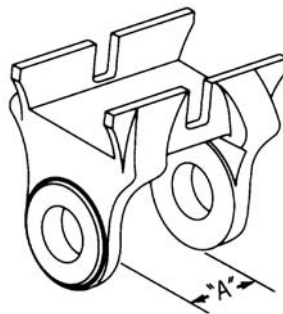

CAUTION

THE THREE-PIECE ADAPTER ASSEMBLY MUST BE INSTALLED WITH INTERMEDIATE TUBE.

Raise the beam end into the axle bracket and support with jack. Install one adapter through the axle bracket leg at the wheel side, into the beam end bushing. Then install the other adapter through the axle bracket leg at the bowl side with the Grade 8 bolt and washer, taking advantage of the cut off flange on the adapter to clear the bowl.

Split ring adapters are available where lack of clearance will not permit the use of standard adapters.

Rotate the adapters so that the adapter cut off flats are vertical as shown in Figure 23. If split ring adapters are used, rotate the split ring flanges so that the split is vertical. Assemble the locknut and washer, and with the axle in its normal operating position, tighten the locknut. For the **HN-400** tighten $\frac{3}{4}$ " locknuts to 210 to 240 foot pounds. For the **HN-460** tighten 1" locknuts to 445 to 495 foot pounds torque. **Do not exceed specified torque.**

Figure 23

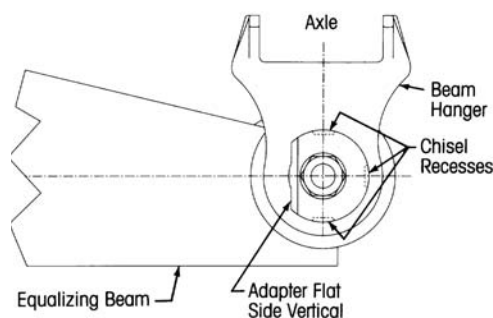

WARNING

IF THE TIGHTENING TORQUES RECOMMENDED ABOVE ARE NOT ACHIEVED, METAL SURFACES WILL WORK AND WEAR THE AXLE BRACKET LEGS, HOLES, ADAPTERS AND RUBBER BUSHING INNER METALS. PROPERLY TIGHTENED BEAM END CONNECTIONS WILL ELIMINATE COSTLY REPAIR, DOWNTIME, POSSIBLE SEPARATION OF COMPONENTS, AND LOSS OF VEHICLE CONTROL, PROPERTY DAMAGE OR PERSONAL INJURY.

The part numbers and identification for the three-piece adapter assemblies are shown in Figures 24 and 25 on the following page for the HN-400 and HN-460. Each adapter assembly contains enough parts for one beam end connection.

Figure 24
HN-400 Beam End Bushing and
Beam End Adapter Connection

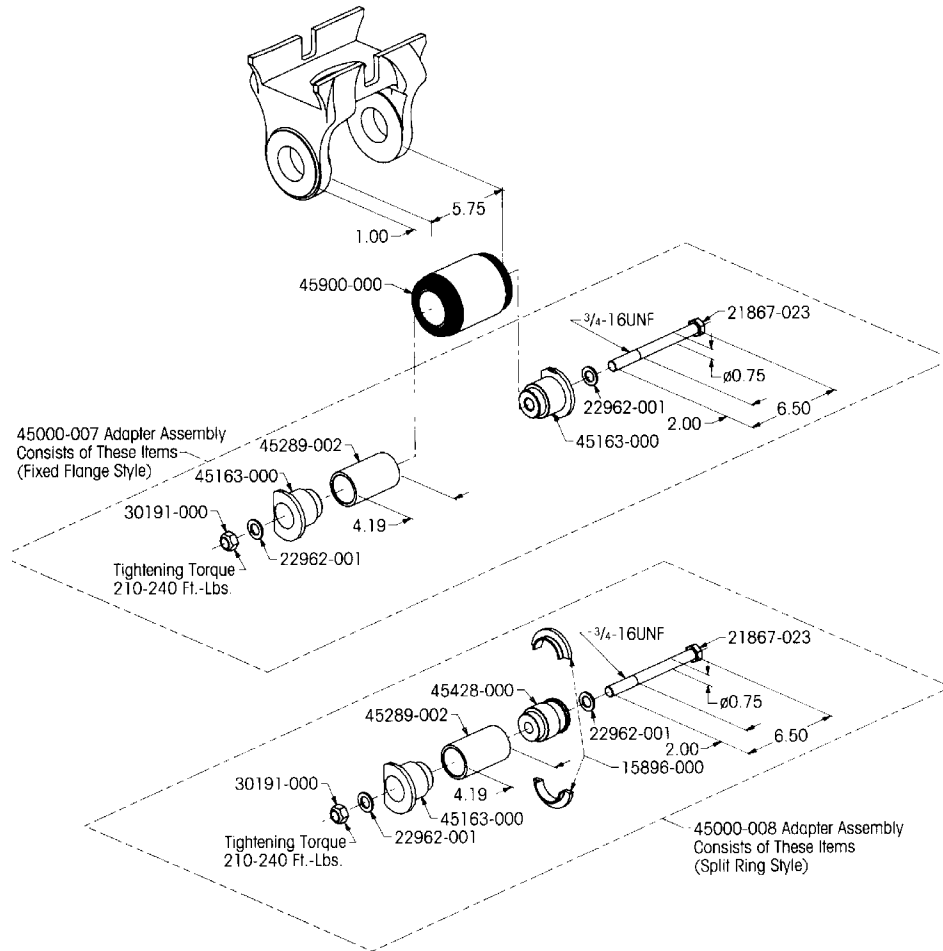

NOTE: Adapter assemblies must not be used without intermediate tube 45289-002.

Figure 25
HN-460 Beam End
Bushing and Beam End
Adapter Connection

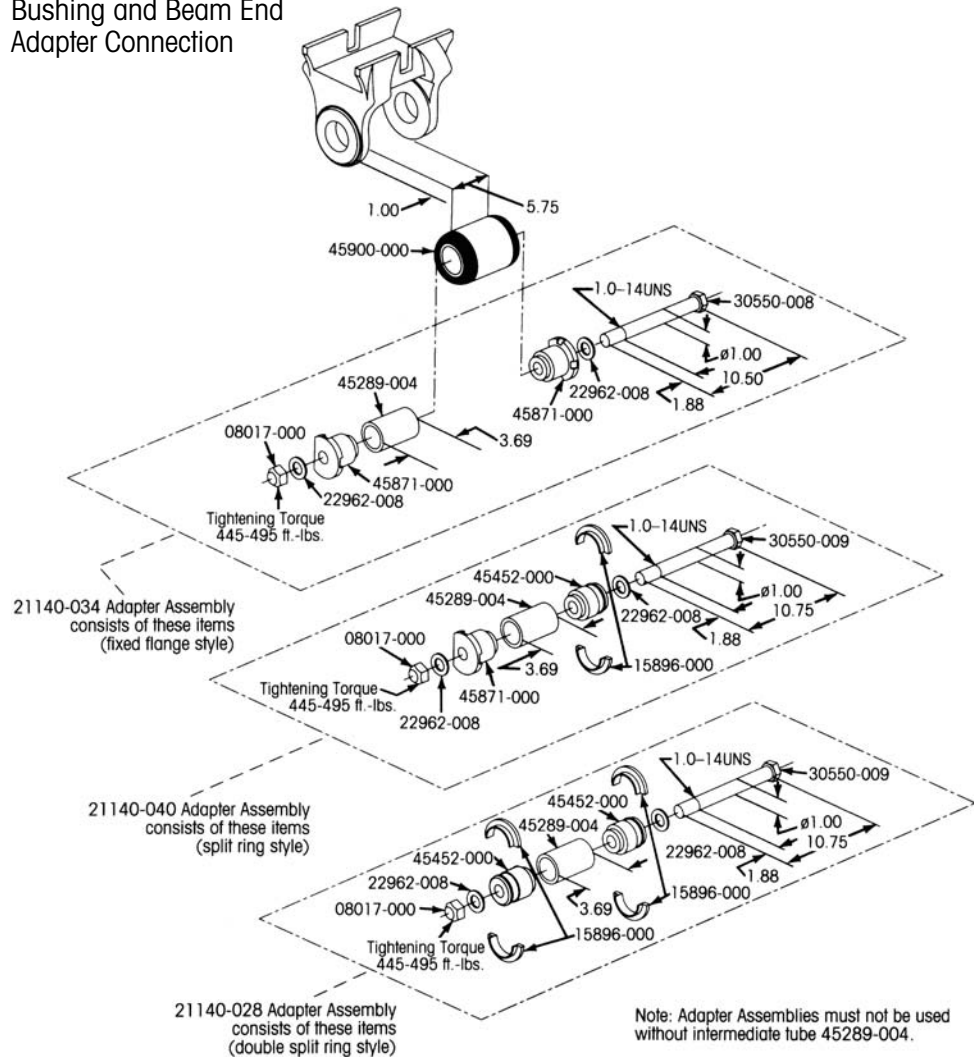

BAR PIN BEAM END BUSHINGS

Apply a penetrating oil to the threads of 1" diameter bolts and locknuts that connect the end bushing inner metal to the axle bracket. While supporting the end of the beam, remove the bolts. If the fasteners are rusted in place, an air hammer chisel may be used to loosen the bolt from the axle bracket and bushing.

NOTE

The upper torque rods may have to be disconnected at the top of the axle and the axle rotated to a more vertical position to assist in the removal of the bar pin bushing from the axle bracket.

CAUTION

SUPPORT THE END OF THE BEAM AS IT MAY DROP WHEN THE THROUGH BOLTS ARE REMOVED. AFTER ALL FASTENERS ARE REMOVED THEY SHOULD BE DISCARDED, DO NOT REUSE THE FASTENERS.

SERVICE HINT

Providing proper pinion angle is established prior to removal of bar pin bushings, it is helpful to mark the angle of the bar pin bushing holes on the beam end. This will aid in the reinstallation of the beam into the axle brackets. See Figure 26.

Figure 26

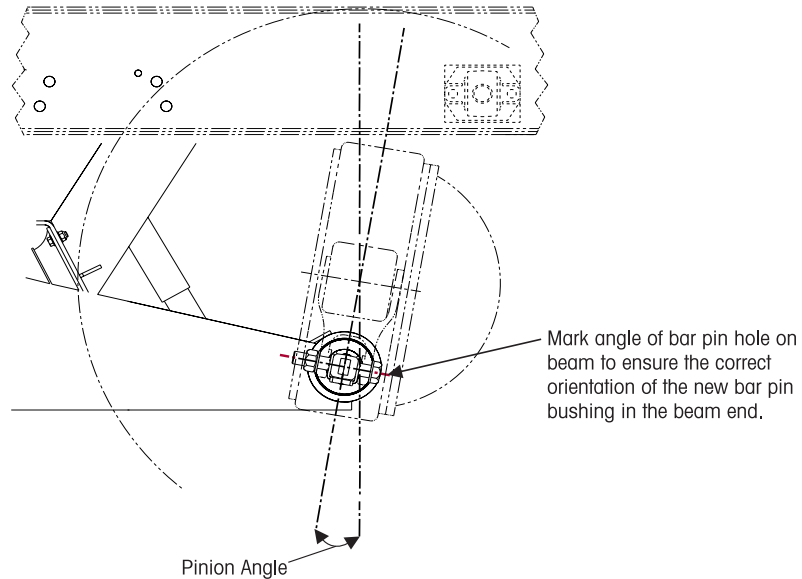

If proper pinion angles are undetermined use the following procedure to install bar pin bushings. Place the equalizing beam in the shop press with the beam end bore squarely supported on the bed for safety and to avoid bending the equalizing beam.

Prior to pressing the bar pin bushing into the holes of the beam bore ensure that the bar pin holes follow the same orientation as in the centerline of the beam. See Figure 27. This will ease the reinstallation of the assembly into the axle brackets.

Figure 27

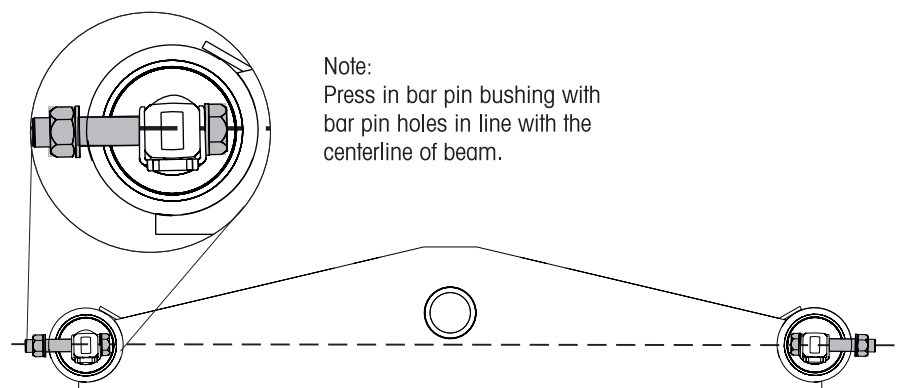

 **WARNING**

WHEN REMOVING AND INSTALLING BUSHINGS IN THE EQUALIZING BEAMS, FOLLOW THE PROCEDURES OUTLINED IN THIS PUBLICATION. DO NOT USE A CUTTING TORCH TO REMOVE THE BUSHING OUTER METALS PRESSED IN THE BEAM BORES. WELDING, TORCHING OR ATTACHING MATERIAL TO THE EQUALIZING BEAM MUST NEVER BE PERFORMED. THE USE OF HEAT ADVERSELY AFFECTS THE STRENGTH OF THE BEAMS.

After removing the equalizing beam bushings, thoroughly inspect each beam bore. If torch undercutting is found from previous rebushing, replace with a new equalizing beam. Do not take the responsibility for possible road failure by rebushing a beam in this condition.

The Bar Pin Style rubber end bushings can be removed with Owatonna Tool Company's tooling or with shop made tools. If Owatonna Tool Company's is to be used, follow their instructions. When using these tools it is important that they are positioned against the edge of the outer metal of the bushing for pressing into the end bore of the equalizing beam.

Begin by removing the confinement washer from one end of the bushing for pushing tool clearance. This may require the use of a chisel where the washer has been staked to the inner casting of the bushing as shown in Figure 28 and 29.

Then cut the protruding rubber on the same end of the beam end bushing as shown in Figure 30. This permits the pushing tool to contact the outer metal of the bushing.

A piece of 4¼" O.D. by 5" long steel tubing can be used to remove the bushing. Use a shop press with a capacity of at least 80 tons. Place the equalizing beam in the shop press with the beam end bore squarely supported on the press bed for safety and to avoid bending the equalizing beam.

Center the pushing tool on the outer metal of the bushing and push the bushing out of the beam bore.

The outer metals of some Hendrickson rubber bushings are covered with a phosphate coating which acts as a rust preventive. This coating must be removed with emery cloth before installation. Also apply a coating of grease to the cleaned outer metals of the bushings and to the beam bores to facilitate pressing the new bushings into the beam bores.

Figure 28

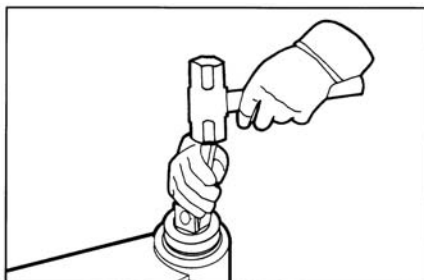

Figure 29

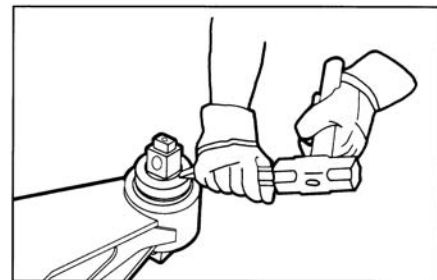
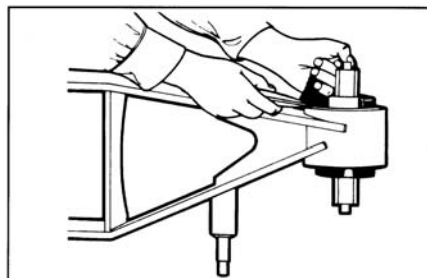

Figure 30



Rubber end bushings can be installed with Owatonna Tool Company's tools or with shop made tools. If Owatonna Tool Company's tools are used, follow their instructions. Care must be taken during installation of the bushing. Do not push on the inner metal or bushing damage will result.

If shop made tooling is to be used, a piece of 1/2" wall by 5" O.D. by 4 5/8" long steel tubing, must be reworked as detailed in Figure 31, to install the bar pin end bushings. The assembly tool must be split in half then clamped or bolted together to compress the rubber to allow contact with the bushing outer metal, as shown in Figure 31.

Figure 31

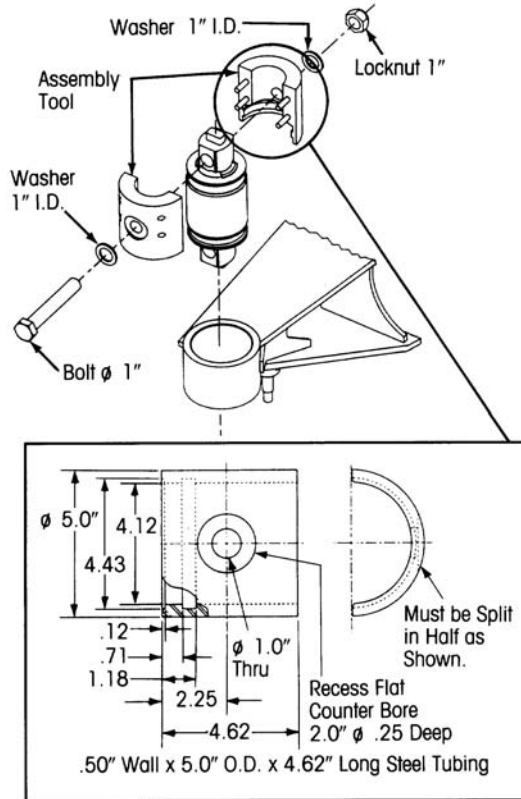

Place the equalizing beam in the shop press with the beam end bore squarely supported on the bed for safety, and to avoid bending the equalizing beam. After installation of the bar pin bushings into the beam bore, verify that the new bushings are centered in the beam end hub. See Figure 32.

When using the 34013-088 bar pin bushing kit with alignment shims refer to Service Bulletin 17730-213 for instructions. When using the bushings with the alignment shims it is **mandatory** that the shims be in place and fasteners properly torqued before operating the vehicle.

Figure 32

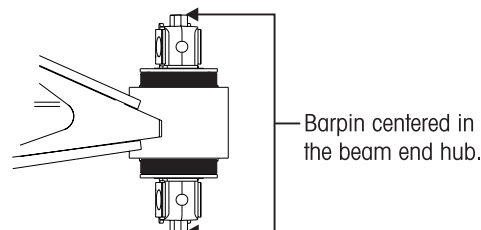

WARNING

A SHIM MUST BE INSTALLED AT EACH BOLT LOCATION. THE SAME PART NUMBER SHIM IN THE SAME ORIENTATION MUST BE USED AT BOTH BOLT LOCATIONS ON ANY ONE BUSHING ASSEMBLY. DO NOT INSTALL OR STACK MORE THAN ONE SHIM AT EACH BOLT LOCATION. USE GENUINE HENDRICKSON SHIMS, DO NOT USE STANDARD WASHERS. THE FAILURE TO FOLLOW THESE WARNINGS MAY RESULT IN THE FRACTURE OF EITHER THE BRACKET OR BAR PIN WHICH COULD RESULT IN THE LOSS OF VEHICLE CONTROL AND POSSIBLE PERSONAL INJURY OR PROPERTY DAMAGE.

Prior to assembly, axle bracket cleaning inspection is required. For Beam End **Bar Pin Style** inspect the $1\frac{3}{32}$ " diameter holes in each of the four (4) axle bracket legs as shown in Figure 33. Look for hairline cracks between the edge of the axle bracket leg and the $1\frac{3}{32}$ " hole. Excessive wear caused by contact with the 1" diameter bar pin connection bolts should also be cause for axle bracket replacement. Contact the axle manufacturer for instructions.

The dimension between the inside surfaces of the axle bracket legs must be 2.313/2.263" as shown in Figure 34.

Any cracks detected near the top of the axle bracket legs as shown in Figure 34 requires replacement of the axle bracket.

Remove any burrs prior to assembly; this will aid in the assembly process. Raise the beam end into the axle bracket and support it with jack.

Figure 33

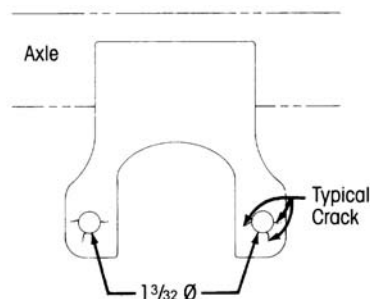
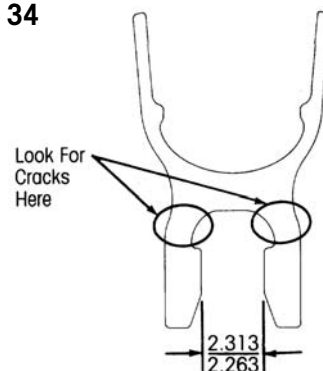

Figure 34



SERVICE HINT

If the axle pinion angle causes difficulty in assembly, disconnect the upper torque rod and rotate the axle so that the bar pin slips into the bracket. For minor adjustments, there are lugs on the ends of the bar pin bushing. With an open-end wrench or Owatonna Tool Company's tooling, the inner metal of the bushing can be rotated slightly to ease assembly.

Prior to assembly of the fasteners, the operator must reconfirm that if the shim style bar pin bushing is used, all the shims are installed.

WARNING

A SHIM MUST BE INSTALLED AT EACH BOLT LOCATION. THE SAME PART NUMBER SHIM IN THE SAME ORIENTATION MUST BE USED AT BOTH BOLT LOCATIONS ON ANY ONE BUSHING ASSEMBLY. DO NOT INSTALL OR STACK MORE THAN ONE SHIM AT EACH BOLT LOCATION. USE GENUINE HENDRICKSON SHIMS, DO NOT USE STANDARD WASHERS. THE FAILURE TO FOLLOW THESE WARNINGS MAY RESULT IN THE FRACTURE OF EITHER THE BRACKET OR BAR PIN WHICH COULD RESULT IN THE LOSS OF VEHICLE CONTROL AND POSSIBLE PERSONAL INJURY OR PROPERTY DAMAGE.



Figure 35
34013-088
Bar Pin Bushing Kit with Alignment Shims

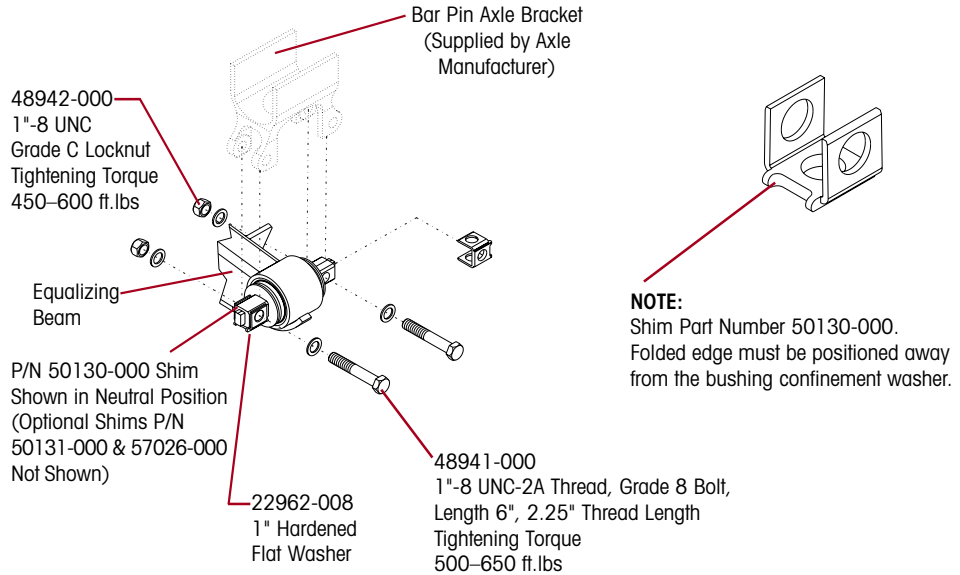
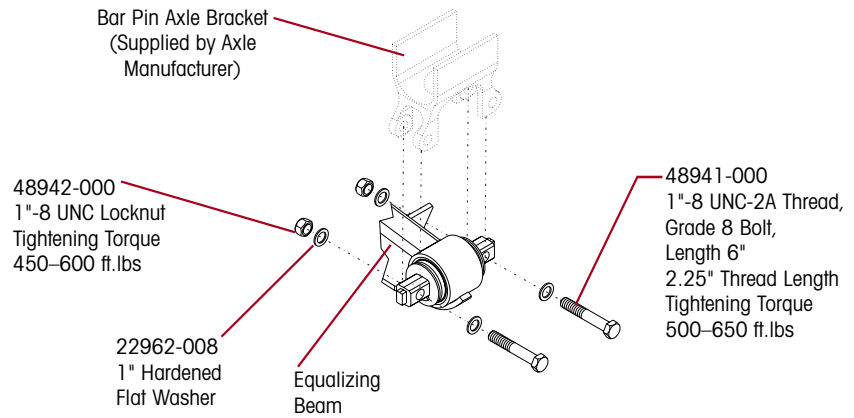

Figure 36
34013-087
Bar Pin Bushing Kit without Alignment Shims



With the longitudinal torque rods disconnected assemble the bolts, washers and locknuts with the bolt heads facing the saddle. Tighten the locknuts to 450 to 600 foot pounds torque. Reconnect the torque rods prior to moving the vehicle.

For detailed alignment procedures and instructions, refer to Hendrickson Technical Publication 17730-213.

Figure 35 and 36 shows the pad numbers for both styles of bar pin bushings along with attaching hardware. Each kit contains all the components required for one beam end.

BOLSTER SPRINGS

Replacement of individual bolster springs is possible from under the vehicle without removing the tires, rims or wheels.

Remove the shock absorbers and the rebound spring.

Raise the frame enough to remove any loading into the bolster springs. Remove the upper bolster spring bolts, nuts, and washers. Raise the frame an additional 4". Remove the lower bolster spring bolts, nuts, and washers. Remove the bolster springs.

Position the new bolster springs in the equalizing beam and install the lower bolts, nuts, and washers. The bolt heads must be positioned at the rubber side of the springs. Tighten the locknuts to 33 to 45 foot pounds torque as shown in Figure 37. Lower the frame until the saddle contacts the bolster springs. Install the upper bolster spring bolts, nuts, and washers. The bolt heads must be positioned at the rubber side of the springs. Tighten to 33 to 45 foot pounds torque as shown in Figure 37.

Lower the frame and install the shock absorbers and the rebound spring.

Figure 37

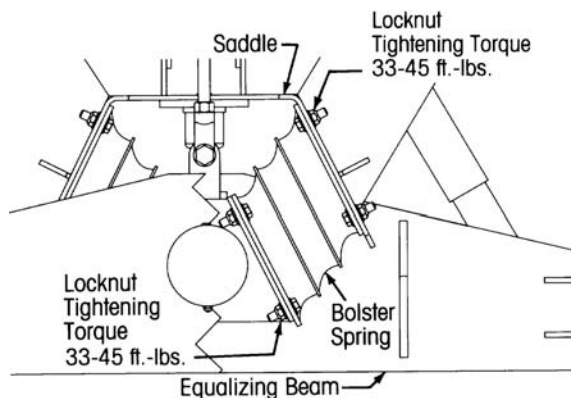

TORQUE ROD AND TRANSVERSE ROD BUSHINGS

WARNING

IT IS POSSIBLE THAT THE EQUALIZING BEAM END CONNECTIONS TO THE AXLE BRACKETS ARE LOOSE. IF THEY ARE, THE AXLES COULD BE FREE TO PIVOT ON THE BEAM ENDS. USE NECESSARY BLOCKING TO PREVENT HARM TO PERSONNEL AND TO AVOID DAMAGE TO THE DRIVE LINES, POWER DIVIDER AND DIFFERENTIAL CARRIERS.

Straddle mount rod ends, as shown in Figures 38 and 39, may be removed by removing the locknuts, bolts, washers and any adjustment shims. Note the number of shims at each location as they must be reinstalled in the same manner to avoid affecting axle.

Use Owatonna Tool Company's tool set to remove and install the rod bushings. Follow their instructions.

The rod assembly part number is metal stamped on the center of the rod shank as shown in Figure 40. Replacement cartridges are available for both the Straddle Mount (part no. 44695) and for the Tapered Stud (part no. 44967-000).

Figure 38

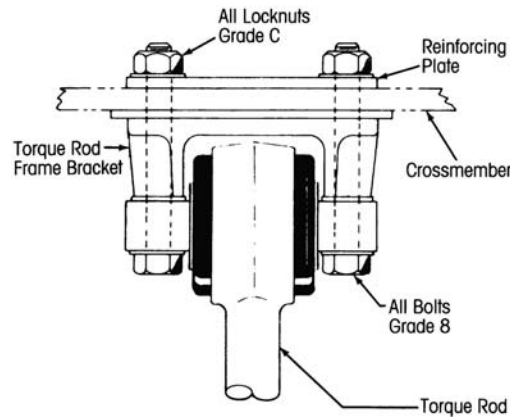
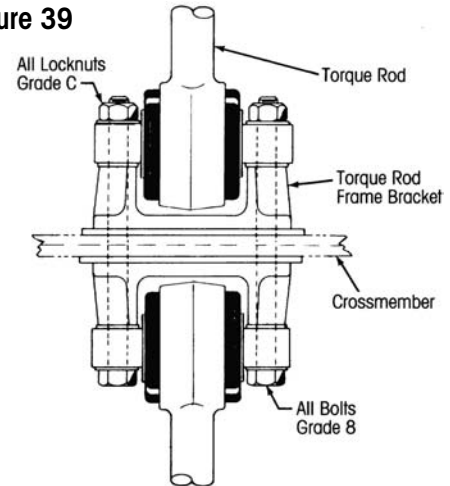

Figure 39



Two-piece rods with either tapered stud or straddle mount ends are also available. They are cut and welded to the desired length in the field. See Hendrickson Suspension Bulletin No. 45745-020 for complete details.

To install a straddle mount end, position the rod end at the bracket, and assemble the bolts, washers, locknuts and any adjustment shims as noted during disassembly. The vehicle manufacturer furnishes the attaching fasteners. Follow their tightening torque specifications.

To install a tapered stud end, the bracket hole must be free of all foreign matter. Place the stud in the bracket and assemble the locknut with spacer washer and tighten the locknut to 175 to 225 foot pounds torque. After tightening, rap the bracket with a hammer as shown in Figure 40 and retighten to 175 to 225 foot pounds torque.

Figure 40

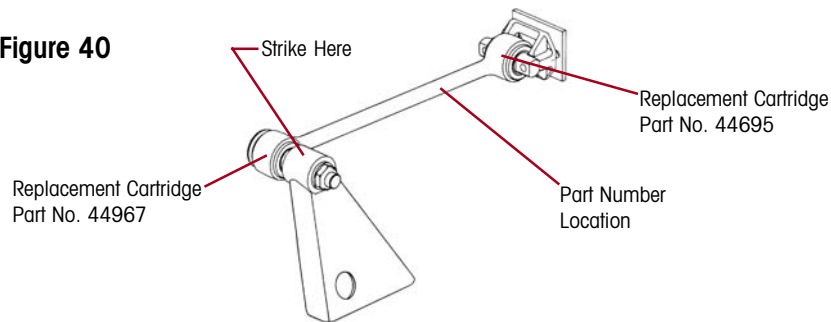

BEAM CENTER CROSS TUBE

The cross tube is a one-piece tube which is unlikely to be required to be removed. If removal is necessary it can be removed by raising the frame enough to remove any loading into the cross tube. Remove the beam center cap nuts and bolts. Remove center caps and drive out the cross tube. After replacing the cross tube, reassemble the center caps, bolts, washers and nuts, and tighten locknuts as shown in Figure 41.

Figure 41

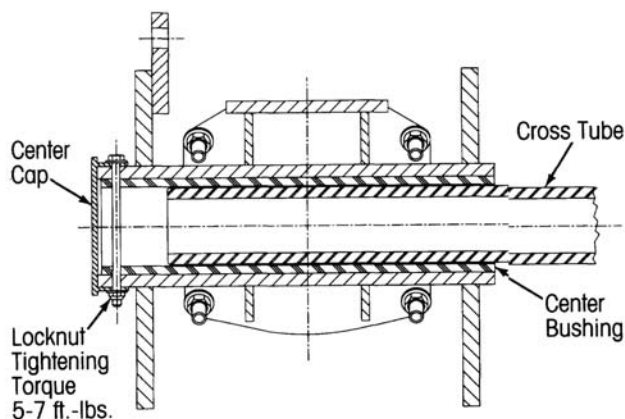

BEAM CENTER BUSHINGS

If it is required to replace the beam center bushings, they can be removed by the use of a three leg puller, or driven out, after first removing the center cap nuts, bolts, center caps, and cross tube. New nylon bushings can then be pressed in place. The center bushings have cross drilled holes near the end which must be positioned to line up with matching holes in the equalizing beam center hub. After replacing center bushings, reassemble the cross tube, center caps, bolts, washers and nuts, and tighten locknuts as shown in Figure 41. A piece of $\frac{1}{2}$ " O.D. by 5" long steel tube will remove the bushings. Use a shop press with a capacity of at least 8.5 tons. Center the pushing tool on the outer metal of the bushing and push the bushing out.

Bushing installation is the reverse of removal. Apply coating of white lead or grease to outer metals of bushings and bores of torque arm to facilitate pressing the new bushings into the bores.

JOUNCE STOP AND REBOUND CONTROL ASSEMBLIES

Raise the frame enough to remove any loading into bolster springs. Remove the rebound spring control rod jam nut, threaded washer, and rebound control spring. Remove the rebound bumper control rod clevis locknut and bolt, and remove the control rod and clevis assembly. The jounce stop mounted to the underside of the saddle can then be removed by removing the $\frac{5}{16}$ " diameter bolts and locknuts. Install the new jounce stop to the underside of the saddle and assemble the bolts and locknuts with the bolt heads down, and tighten the locknuts as shown in Figure 42.

Install the rebound spring control rod and clevis through the saddle bracket and position the clevis on the equalizing beam mounting tab. Install the clevis bolt and locknut as shown in Figure 43. Tighten the locknut but do not pinch clevis up tight.

Figure 42

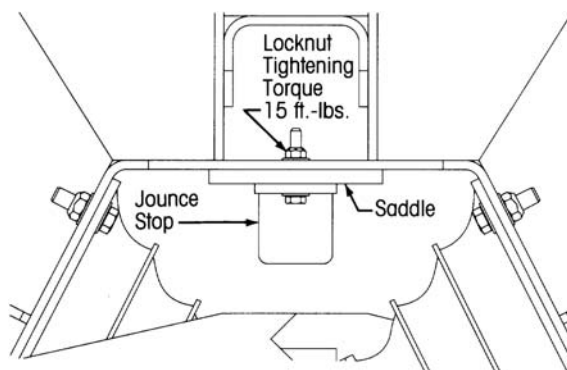
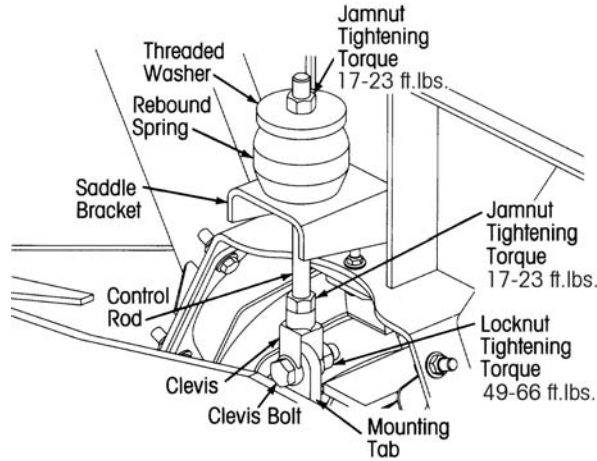

Figure 43



The clevis must be free to rotate. Install the new rebound spring, threaded washer, and jam nut on control rod above the saddle bracket but do not tighten at this time. Lower the frame, and adjust the control rod threaded washer as specified in the preventive maintenance section of this manual (see Jounce Stop and Rebound Control Assemblies, page 11, Figure 15). After making the correct adjustment, tighten the jam nut to 17-23 foot pounds torque as shown in Figure 43.

SHOCK ABSORBERS

Remove the top and bottom locknuts and washers. Remove the shock absorbers. Install the new shock absorbers with washers and locknuts as shown in Figure 44. The larger I.D. washer fits over the shoulder of the stud, and the smaller I.D. washer is then installed over the threaded end of the stud. Tighten the locknuts to 70-90 foot pounds torque.

Figure 44

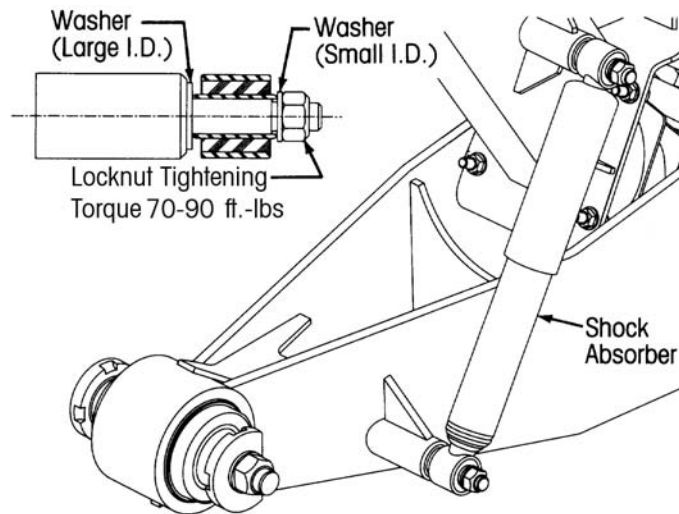

Subject 9
HNT SUSPENSION FOR
TRAILER APPLICATIONS

When the HN Suspension is installed on a trailer, "A" frame type torque rods are used in place of the longitudinal torque rods and transverse rods. Figure 45.

"A" FRAME TORQUE ROD SERVICE REMOVAL

Place jack under chassis and raise to remove weight from the suspension. Remove the locknut from the apex of the torque arm located at the axle pillar. Separate the torque arm from the axle pillar by using a shop made wedge tool. The bushing is located on a tapered pin.

Raise the torque arm on chassis jacks to enable the axle pillar to be withdrawn from the torque arm. This relieves the bushings in the base of the torque arm from any tension.

Remove the locknuts at the bushings at the base of the torque arm.

NOTE

When nuts and bolts have been removed, replace with new Hendrickson supplied bolts, nuts and washers.

"A" frame torque arm replacement is to be carried out in reverse as above, paying attention to torque settings indicated on Tightening Torque Specification Chart at the end of this publication.

HNT BUSHING REPLACEMENT

A piece of 1/2" O.D. by 5" long steel tube will remove the bushings.

Use a shop press with a capacity of at least 8.5 tons.

Place the "A" Frame in the press with the bushing bore squarely supported on the press bed for safety and to avoid bending the "A" frame.

Center the pushing tool on the outer metal of the bushing and push the bushing out.

Bushing installation is the reverse of removal. Apply coating of white lead or grease to outer metals of bushings and bores of torque arm to facilitate pressing the new bushings into the bores.

Figure 45

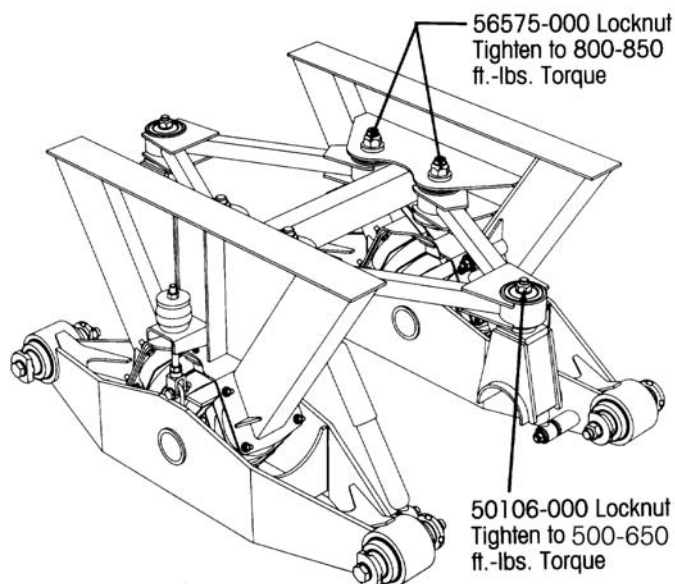

Subject 10
TIGHTENING TORQUE
SPECIFICATION CHART

Description	Part No.	Hendrickson Thread/Grade	Torque Ft./Lbs.
Saddle to Frame Bolts, Nuts, & Washers	none	Furnished & Installed by Truck Manufacturer	*
Shock Absorber Locknut	30585-000	5/8"-18 UNF-2B Grade C	70-90
Bolster Spring Bolt Locknut	48949-000	7/16"-20 UNF-2B Grade C	33-45
Transverse Rod Locknut (tapered stud)	29749-000	1 1/8"-12 UNC-2B Grade 5	175-225
Torque Rod Locknut (straddle mount)	none	Furnished and Installed by Truck Manufacturer	*
HN-400 Beam End Adapter Bolt Locknut	30191-000	3/4"-16 UNS-2B Grade C	210-240
HN-460 Beam End Adapter Bolt Locknut	08017-000	1"-14 UNS-2B Grade C	445-495
Bar Pin Bushing Locknut	48942-000	1" -8 UNC Grade C	450-600
Bar Pin Bushing Bolt Head	48941-000	1" -8 UNC-2A Grade 8	500-650
Jounce Stop Locknut	48948-000	5/16"-24 UNF Grade C	15
Rebound Spring Clevis Bolt Locknut	47764-000	5/8"-11 UNC-2B Grade C	49-66
Rebound Spring Control Rod Jam Nut	49778-000	5/8"-18 UNF-3B Grade B	17-23
Beam Center Cap Nut	49983-000	1/4"-20 UNC-2B Grade B	5-7
HNT Suspension "A" Frame Torque Arm Locknut	50106-000	7/8"-9 UNC Grade C	500-650
HNT Suspension "A" Frame Torque Arm Locknut	56575-000	1 1/8"-7 UNC-2B Grade C	800-850

All threads must be clean and lubricated with SAE 20 oil before assembly to obtain the correct relationship of torque and fastener tension.

To obtain maximum service life from the suspension system, mounting bolts and nuts should be checked at least once a year and tightened to specified torque.

IMPORTANT NOTE

*Torque values listed above apply only if Hendrickson supplied fasteners are used. If non-Hendrickson fasteners are used, follow torque specifications listed in vehicle manufacturer's service manual.

