

H[®] TECHNICAL BULLETIN

COMPOSILITE[®] SC Truck Mount Enhancement

SUBJECT: Compliant Tie Rods (CTR) Adjustability Enhancements

LIT NO: TB-H793

DATE: September 2019

REVISION: A

INTRODUCTION

NEW COMPLIANT TIE ROD (CTR) ADJUSTABILITY ENHANCEMENTS

This publication is intended to inform Hendrickson Specialty Products – Auxiliary Axle customers of an enhancement to the Compliant Tie Rod (CTR) equipped on new steerable COMPOSILITE[®] SCT08, SCT10 and SCT13 lift axles for **truck applications**.

As of November 16, 2015, these models will be equipped with the **NEW CTR** design with enhanced toe setting adjustability and will be standard on vehicle applications.

The CTR delivers the industry's first passive steer Ackermann with **lubrication-free connections** and **resistance to permanent deformation**.

The **NEW** product design enhances adjustability by increasing in the length of the slotted hole and incorporating a larger eccentric washer, see Figure 1.

*CTR Kit Numbers

SCT08 – R-014436-10

SCT10 – R-014436-10

SCT13 – R-014436-13

CONTENTS

DESCRIPTION	QTY.
CTR	1
CTR Ends	2
Eccentric Washer	2
5/8" Fasteners	18

* Contents will vary per suspension capacity

FIGURE 1

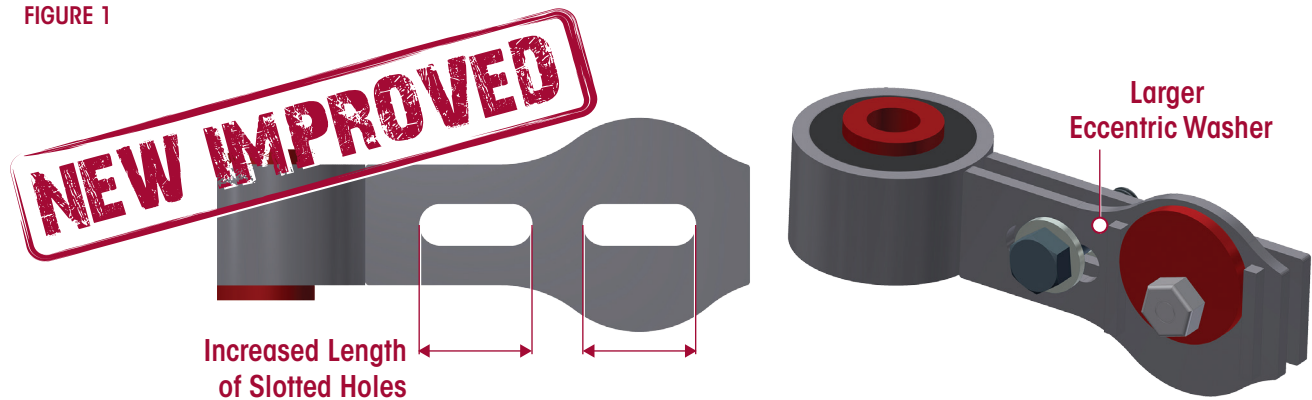

Aftermarket CTR Assembly Service Kits Number R-014436-XX for the SCT08, SCT10 and SCT13 will be available for purchase as of November 16, 2015.

Refer to the Hendrickson Auxiliary Axle Systems Steerable Lift Axle publication TP-H785 Tie Rod Installation and Toe Setting Procedure for more information available online at www.hendrickson-intl.com.

Contact Hendrickson Specialty Products — Auxiliary Axle Systems for more information regarding any new or existing COMPOSILITE Truck Mount Lift Axle applications.

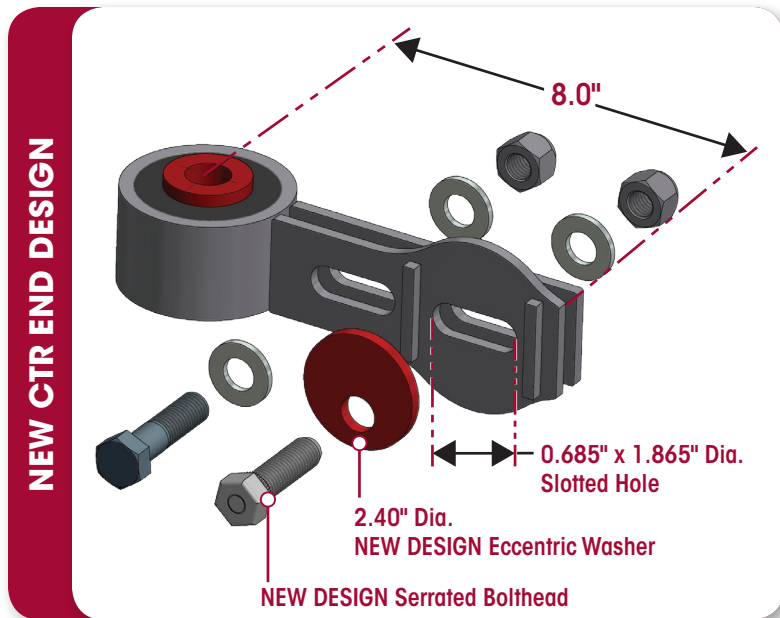

NEW IMPROVED

NEW DESIGN — As the serrated bolt head is turned the eccentric washer with inboard grooved ridges will rotate in the same direction of the bolt head to adjust toe.

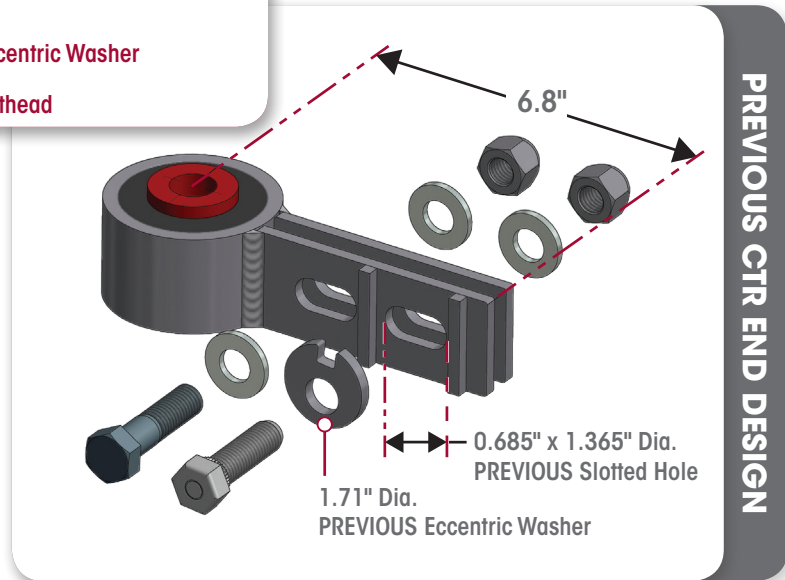

PREVIOUS DESIGN — Toe adjustment was done with a wrench placed in the notch of the eccentric washer.

Refer any questions on this publication to Hendrickson Auxiliary Axle Systems Tech Services:



Toll-free U.S. and Canada
1.800.660.2829
Outside U.S. and Canada
1.740.929.5600



Parts Identification
LiftAxle@hendrickson-intl.com
Technical Support
LiftAxleTech@hendrickson-intl.com



1.740.929.5601



Additional Hendrickson
Product Information
www.hendrickson-intl.com

*Actual product performance may vary depending upon vehicle configuration, operation, service and other factors.
All applications must comply with applicable Hendrickson specifications and must be approved by the respective vehicle manufacturer with the vehicle in its original, as-built configuration.
Contact Hendrickson for additional details regarding specifications, applications, capacities, and operation, service and maintenance instructions.*

Call Hendrickson at **800.660.2829** or **800.668.5360** in Canada for additional information.



www.hendrickson-intl.com

**SPECIALTY PRODUCTS -
AUXILIARY AXLE SYSTEMS**
277 North High Street
Hebron, OH 43025 USA
800.660.2829
740.929.5600 • Fax 740.929.5601

Hendrickson Canada
250 Chrysler Drive, Unit #3
Brampton, ON Canada L6S 6B6
800.668.5360
905.789.1030 • Fax 905.789.1033