



H TECHNICAL PROCEDURE

HTB® 210 Rear Air Suspension for Spartan Motorhome Chassis

SUBJECT: Service Instructions

LIT NO: 17730-261

DATE: March 2015

REVISION: B

TABLE OF CONTENTS

Section 1	Introduction	2	Section 8	Component Replacement	36
Section 2	Product Description	2	Fasteners	36	
Section 3	Important Safety Notice	4	Air Spring	36	
Section 4	Parts Lists	8	Height Control Valve	38	
Section 5	Special Tools	16	Shock Absorber	39	
Section 6	Preventive Maintenance	17	Longitudinal Torque Rod	39	
Component Inspection	17		Longitudinal Torque Rod Bushing	42	
U-Bolt Locknuts	18		Torque Box	44	
Torque Box	18		Clamp Group – Top Pad, Lower Air Spring Bracket, U-Bolts	46	
Lateral Alignment Inspection	18		Axle Stop	50	
Axle Brackets	19		Frame Hanger (Mid-Engine and Rear-Engine)	50	
Longitudinal Torque Rods	19		Cross Member and Gusset	52	
Air Fitting Inspection	20		Section 9	Plumbing Diagram	55
Shock Absorber Inspection	20		Section 10	Torque Specifications	56
Section 7	Alignment & Adjustments	22	Section 11	Troubleshooting Guide	64
Ride Height adjustment	22				
Axle Alignment and Adjustments	24				
Pinion Angle	33				
Auxiliary Axle Wheel Bearing Adjustment	34				

SECTION 1

Introduction

This publication is intended to acquaint and assist maintenance personnel in the preventive maintenance, service, repair and rebuild of the Hendrickson HTB® 210 suspension systems as installed on applicable Spartan Motorhome Chassis.

NOTE

Use only Genuine  Hendrickson parts for servicing this suspension system.

It is important to read and understand the entire Technical Procedure publication prior to performing any maintenance, service, repair, or rebuild of this product. The information in this publication contains parts lists, safety information, product specifications, features, proper maintenance, service, repair and rebuild instructions for the HTB 210 Drive Tag, HTB 210 Mid Engine, and HTB 210 Rear Engine Suspensions.

Hendrickson reserves the right to make changes and improvements to its products and publications at any time. Contact Hendrickson Tech Services for information on the latest version of this manual at 1-866-755-5968 (toll-free U.S. and Canada), 1-630-910-2800 (outside U.S. and Canada) or e-mail: techservices@hendrickson-intl.com.

The latest revision of this publication is also available online at www.hendrickson-intl.com.

SECTION 2

Product Description

The HTB® lightweight, non-torque reactive rear air suspension system combines superior ride, improved stability, reduced weight and reduced maintenance. Unique design and components make the HTB 210 a reliable, rugged and light weight suspension.

- **Air springs** — HTB 210 improves ride over typical trailing-arm suspensions by supporting the entire load on large volume air springs.
- **Torque box** — HTB 210's unique, maintenance-free torque box system improves multi-axial stability and control. The parallelogram design controls suspension windup and corresponding frame rise. Maintaining pinion angles throughout axle travel reduces suspension-induced driveline vibration and extends driveline component life.
- **Rubber bushings** — All pivot points come equipped with premium rubber bushings requiring no lubrication. Torque box bushings are designed for long life.
- **U-bolts** — Re-torque of the clamp group is reduced since no twisting is applied to the clamp group.
- **Axle alignment** — The torque box, torque rods and clamp group joints provide consistent axle alignment and reduce the need for re-alignment.



HTB® 210 SPECIFICATIONS¹

	Drive Tag ²	Mid Engine	Rear Engine
Capacity (Up to)	21,000 lbs	21,000 lbs	21,000 lbs
Installed Weight	333 lbs	371 lbs	370 lbs
Off-highway Rating	10%	10%	10%
Axle Configuration	Single	Single	Single
GVW Approval	55,000 lbs	55,000 lbs	55,000 lbs
GCW Approval	120,000 lbs	120,000 lbs	120,000 lbs
Ride Heights	8.5"	8.5"	8.5"
Engine Torque Restrictions	None	None	None
Axle Spacing	48"	N/A	N/A

¹ Actual product performance may vary depending upon vehicle configuration, operation, service and other factors. All applications must comply with applicable Hendrickson specifications and must also be approved by the respective vehicle manufacturer with the vehicle in its original, as-built configuration. Contact Hendrickson and the respective vehicle manufacturer for approval of additional applications.

² Does not include Auxiliary Axle Drive Tag.

FIGURE 2-1 HTB 210 for Spartan Mid Engine

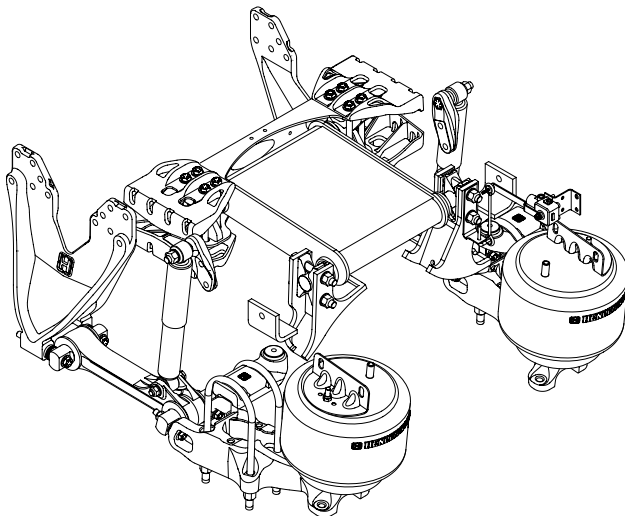

FIGURE 2-2 HTB 210 for Spartan Rear Engine

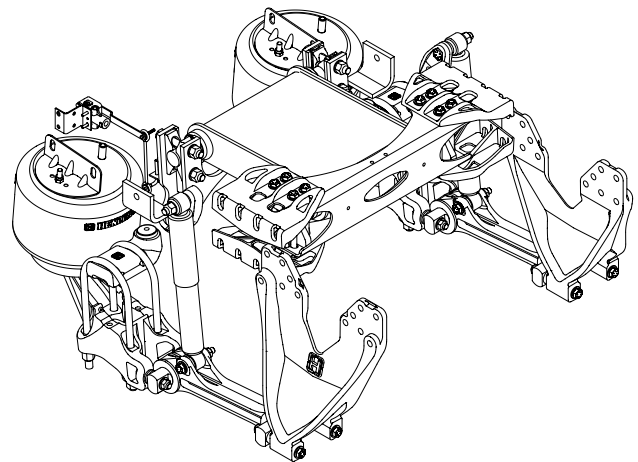

FIGURE 2-3 HTB 210 for Spartan Drive Tag

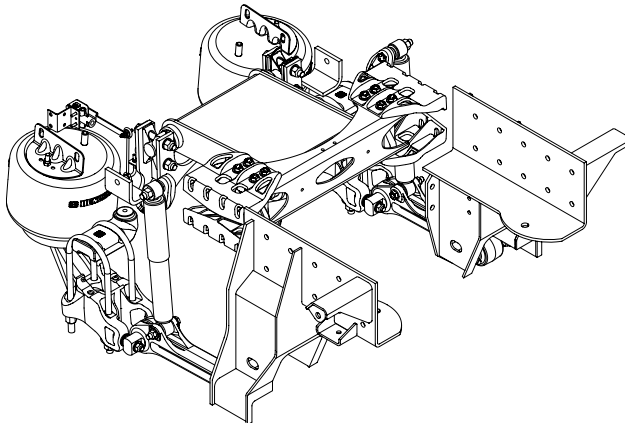
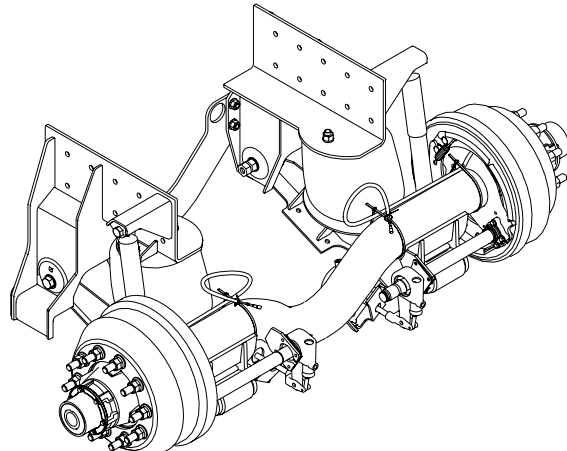

FIGURE 2-4 Auxiliary Axle Drive Tag for Spartan



SECTION 3

Important Safety Notice

Proper maintenance, service and repair is important to the reliable operation of the suspension. The procedures recommended by Hendrickson and described in this technical publication are methods of performing such maintenance, service and repair.

The warnings and cautions should be read carefully to help prevent personal injury and to assure that proper methods are used. Improper maintenance, service or repair may damage the vehicle, cause personal injury, render the vehicle unsafe in operation, or void the manufacturer's warranty.

Failure to follow the safety precautions in this manual can result in personal injury and/or property damage. Carefully read and understand all safety related information within this publication, on all decals and in all such materials provided by the vehicle manufacturer before conducting any maintenance, service or repair.

■ EXPLANATION OF SIGNAL WORDS

Hazard "Signal Words" (Danger-Warning-Caution) appear in various locations throughout this publication. Information accented by one of these signal words must be observed to help minimize the risk of personal injury to service personnel, or possibility of improper service methods which may damage the vehicle or render it unsafe.



This is the safety alert symbol. It is used to alert you to potential personal injury hazards. Obey all safety messages that follow this symbol to avoid possible injury or death.

Additional 'Notes' or 'Service Hints' are utilized to emphasize areas of procedural importance and provide suggestions for ease of repair. The following definitions indicate the use of these signal words as they appear throughout the publication.



INDICATES AN IMMINENTLY HAZARDOUS SITUATION WHICH, IF NOT AVOIDED, WILL RESULT IN SERIOUS INJURY OR DEATH.



INDICATES A POTENTIAL HAZARDOUS SITUATION WHICH, IF NOT AVOIDED, CAN RESULT IN SERIOUS INJURY OR DEATH.



INDICATES A POTENTIAL HAZARDOUS SITUATION WHICH, IF NOT AVOIDED, MAY RESULT IN MINOR OR MODERATE INJURY, OR PROPERTY DAMAGE.

NOTE

An operating procedure, practice condition, etc. which is essential to emphasize.

SERVICE HINT

A helpful suggestion, which will make the servicing being performed a little easier and/or faster.

Also note that particular service operations may require the use of special tools designed for specific purposes. These special tools can be found in the Special Tools Section of this publication.



The torque symbol alerts you to tighten fasteners to a specified torque value. Refer to Torque Specifications Section of this publication.



■ SAFETY PRECAUTIONS



WARNING

FASTENERS

DISCARD USED FASTENERS. ALWAYS USE NEW FASTENERS TO COMPLETE A REPAIR. FAILURE TO DO SO COULD RESULT IN FAILURE OF THE PART, OR MATING COMPONENTS, LOSS OF VEHICLE CONTROL, PERSONAL INJURY, OR PROPERTY DAMAGE.

LOOSE OR OVER TORQUED FASTENERS CAN CAUSE COMPONENT DAMAGE, LOSS OF VEHICLE CONTROL, PROPERTY DAMAGE, OR SEVERE PERSONAL INJURY. MAINTAIN CORRECT TORQUE VALUE AT ALL TIMES. CHECK TORQUE VALUES ON A REGULAR BASIS AS SPECIFIED, USING A REGULARLY CALIBRATED TORQUE WRENCH. TORQUE VALUES SPECIFIED IN THIS TECHNICAL PUBLICATION ARE FOR HENDRICKSON SUPPLIED FASTENERS ONLY. IF NON HENDRICKSON FASTENERS ARE USED, FOLLOW TORQUE SPECIFICATION LISTED IN THE VEHICLE MANUFACTURER'S SERVICE MANUAL.



WARNING

LOAD CAPACITY

ADHERE TO THE PUBLISHED CAPACITY RATINGS FOR THE SUSPENSION. ADD-ON AXLE ATTACHMENTS AND OTHER LOAD TRANSFERRING DEVICES CAN INCREASE THE SUSPENSION LOAD ABOVE ITS RATED AND APPROVED CAPACITIES, WHICH CAN RESULT IN COMPONENT DAMAGE AND LOSS OF VEHICLE CONTROL, POSSIBLY CAUSING PERSONAL INJURY OR PROPERTY DAMAGE.



WARNING

TORQUE BOX CLAMP BOLTS

IT IS IMPORTANT THAT THE TORQUE BOX CLAMP CONNECTIONS BE TIGHTENED IN THE PROPER SEQUENCE AND HAVE THE PROPER TIGHTENING TORQUE VALUES MAINTAINED. FAILURE TO DO SO CAN RESULT IN THE DEFORMATION OF PARTS, RESULTING IN THE LOSS OF CLAMP FORCE, BOLT FAILURE, LOSS OF THE AXLE'S ALIGNMENT, LOSS OF VEHICLE CONTROL, PROPERTY DAMAGE, OR PERSONAL INJURY.



WARNING

TORQUE BOX AXLE BRACKET SPACERS

THE DRIVE AXLE HAS ONE (1) AXLE BRACKET WITH ADJUSTABLE BAR PIN CLAMPS AND FOUR (4) AXLE BRACKET SPACERS, AND ONE (1) AXLE BRACKET WITH NON-ADJUSTABLE BAR PIN CLAMPS. THE BAR PIN CLAMP PAIRS CAN BE CHANGED FROM SIDE TO SIDE BUT CANNOT BE MIXED. ALL FOUR (4) SPACERS MUST BE USED WITH THE ADJUSTABLE BAR PIN CLAMPS, WHICH ARE THINNER THAN THE NON-ADJUSTABLE BAR PIN CLAMPS. FAILURE TO DO SO CAN RESULT IN THE DEFORMATION OF PARTS, LOSS OF CLAMP FORCE, BOLT FAILURE, LOSS OF THE AXLE'S ALIGNMENT, LOSS OF VEHICLE CONTROL, PROPERTY DAMAGE, OR PERSONAL INJURY.



WARNING

U-BOLT CLAMP GROUP CONNECTION

IT IS IMPORTANT THAT THE U-BOLT CLAMP GROUP CONNECTION BE PROPERLY ALIGNED AND HAVE THE PROPER TORQUE VALUES MAINTAINED. METAL SURFACES CAN WORK AND WEAR AGAINST OTHER RELATED CLAMP GROUP COMPONENTS IF NOT PROPERLY ALIGNED OR PROPERLY TIGHTENED TO MAINTAIN THE PROPER CLAMP FORCE. FAILURE TO DO SO CAN CAUSE PREMATURE COMPONENT WEAR, POSSIBLE SEPARATION OF THE CLAMP GROUP, CAUSING LOSS OF VEHICLE CONTROL, PROPERTY DAMAGE, OR PERSONAL INJURY.



WARNING

LONGITUDINAL TORQUE ROD

THE AIR SPRING TRANSFERS LOAD TO THE FRAME HANGER THROUGH THE LONGITUDINAL TORQUE ROD. PRIOR TO LONGITUDINAL TORQUE ROD REMOVAL THE SUSPENSION AIR SYSTEM MUST BE DEFLATED. FAILURE TO DO SO WILL CAUSE THE AXLE HOUSING TO ROTATE AND/OR SHIFT, RESULTING IN POSSIBLE DAMAGE TO COMPONENTS AND/OR PERSONAL INJURY.



WARNING

SHOCK ABSORBERS

THE SHOCK ABSORBERS ARE THE REBOUND TRAVEL STOPS FOR THE SUSPENSION. ANYTIME THE AXLE ON A HTB 210 SUSPENSION IS SUSPENDED IT IS MANDATORY THAT THE SHOCK ABSORBERS REMAIN CONNECTED. FAILURE TO DO SO CAN CAUSE THE AIR SPRINGS TO SEPARATE FROM THE PISTON AND RESULT IN PREMATURE AIR SPRING FAILURE. REPLACEMENT OF SHOCK ABSORBERS WITH NON-HENDRICKSON PARTS CAN ALTER THE REBOUND TRAVEL OF THE SUSPENSION.

 **WARNING****ALUMINUM COMPONENTS**

THE HTB 210 CONTAINS VARIOUS ALUMINUM COMPONENTS. EXERCISE EXTREME CARE WHEN HANDLING OR PERFORMING MAINTENANCE NEAR OR ON ALUMINUM COMPONENTS. DO NOT USE A CUTTING TORCH TO REMOVE ANY ATTACHING FASTENERS. THE USE OF HEAT ON SUSPENSION COMPONENTS WILL ADVERSELY AFFECT THE STRENGTH OF THESE PARTS. A COMPONENT DAMAGED IN THIS MANNER CAN RESULT IN THE LOSS OF VEHICLE CONTROL AND POSSIBLE PERSONAL INJURY OR PROPERTY DAMAGE.

ALUMINUM COMPONENTS WERE DESIGNED TO BE LIGHTWEIGHT OPTIONS WHERE WEIGHT REDUCTION IS DESIRABLE. THEIR USE SHALL BE CONFINED TO APPLICATIONS WHERE THE RATED CAPACITY OF THE SUSPENSION WILL NOT BE EXCEEDED. FAILURE TO LIMIT THE ALUMINUM COMPONENT APPLICATIONS TO RATED CAPACITY CAN RESULT IN FAILURE OF THE COMPONENT AND LOSS OF VEHICLE CONTROL, POSSIBLY CAUSING PERSONAL INJURY OR PROPERTY DAMAGE.

ALUMINUM COMPONENTS SUCH AS, TORQUE RODS, TORQUE ROD BAR PIN, AIR SPRING BRACKETS, CROSS MEMBER GUSSETS, TOP PAD, CROSS BAR, ETC., CAN BE DAMAGED WITH PROLONGED EXPOSURE TO SALT, OR ACID. CONTINUED EXPOSURE CAN RESULT IN A FAILURE OF THESE PARTS AND LOSS OF VEHICLE CONTROL POSSIBLY CAUSING PERSONAL INJURY OR PROPERTY DAMAGE.

ALUMINUM COMPONENTS CAN ALSO BE DAMAGED BY CONTACT WITH HARD OBJECTS WHICH GOUGE THESE PARTS. THESE CONDITIONS COULD RESULT IN A FAILURE OF THESE PARTS WHICH CAN RESULT IN THE LOSS OF VEHICLE CONTROL AND POSSIBLE PERSONAL INJURY OR PROPERTY DAMAGE.

 **WARNING****AIR SPRING INFLATION AND DEFLATION**

PRIOR TO DISASSEMBLY OF THE SUSPENSION, AIR SPRING ASSEMBLIES MUST BE DEFLATED. UNRESTRICTED AIR SPRING ASSEMBLIES CAN VIOLENTLY SHIFT. DO NOT INFLATE AIR SPRING ASSEMBLIES WHEN THEY ARE UNRESTRICTED. AIR SPRING ASSEMBLIES MUST BE RESTRICTED BY SUSPENSION OR OTHER ADEQUATE STRUCTURE. DO NOT INFLATE BEYOND PRESSURES RECOMMENDED BY AIR SPRING MANUFACTURER, CONTACT HENDRICKSON TECHNICAL SERVICES FOR DETAILS. IMPROPER USE OR OVER INFLATION MAY CAUSE AIR SPRING ASSEMBLIES TO BURST, CAUSING PROPERTY DAMAGE AND/OR SEVERE PERSONAL INJURY.

 **WARNING**

PRIOR TO AND DURING DEFLATION AND INFLATION OF THE AIR SUSPENSION SYSTEM, ENSURE ALL PERSONNEL AND EQUIPMENT ARE CLEAR FROM UNDER THE VEHICLE AND AROUND THE SERVICE AREA, FAILURE TO DO SO CAN CAUSE SERIOUS PERSONAL INJURY, DEATH, OR PROPERTY DAMAGE.

 **CAUTION****AIR SPRING INFLATION**

INFLATE THE SUSPENSION SLOWLY, ENSURE THAT THE RUBBER BLADDER OF THE AIR SPRING INFLATES UNIFORMLY AND IS NOT BINDING. FAILURE TO DO SO CAN CAUSE DAMAGE TO THE AIR SPRING AND/OR AIR SPRING MOUNTING BRACKETS VOIDING WARRANTY.

 **CAUTION****AIR SPRING LOWER MOUNTING STUDS**

IF THE AIR SPRING IS BEING REMOVED, IT IS MANDATORY TO LUBRICATE THE LOWER AIR SPRING FASTENERS WITH PENETRATING OIL AND REMOVE WITH HAND TOOLS TO PREVENT DAMAGE TO THE LOWER AIR SPRING MOUNTING STUD. FAILURE TO DO SO CAN CAUSE COMPONENT DAMAGE AND VOID WARRANTY.

 **WARNING****TORCH/WELDING**

DO NOT USE A CUTTING TORCH TO REMOVE ANY FASTENERS. THE USE OF HEAT ON SUSPENSION COMPONENTS WILL ADVERSELY AFFECT THE STRENGTH OF THESE PARTS. A COMPONENT DAMAGED IN THIS MANNER CAN RESULT IN THE LOSS OF VEHICLE CONTROL AND POSSIBLE PERSONAL INJURY OR PROPERTY DAMAGE.



WARNING

MODIFYING COMPONENTS

DO NOT MODIFY OR REWORK PARTS WITHOUT AUTHORIZATION FROM HENDRICKSON. DO NOT SUBSTITUTE REPLACEMENT COMPONENTS NOT AUTHORIZED BY HENDRICKSON. USE OF MODIFIED, REWORKED, SUBSTITUTE OR REPLACEMENT PARTS NOT AUTHORIZED BY HENDRICKSON MAY NOT MEET HENDRICKSON'S SPECIFICATIONS, AND CAN RESULT IN FAILURE OF THE PART, LOSS OF VEHICLE CONTROL, POSSIBLE PERSONAL INJURY OR PROPERTY DAMAGE, AND WILL VOID WARRANTY. USE ONLY HENDRICKSON AUTHORIZED REPLACEMENT PARTS.



WARNING

PERSONAL PROTECTIVE EQUIPMENT

ALWAYS WEAR PROPER EYE PROTECTION AND OTHER REQUIRED PERSONAL PROTECTIVE EQUIPMENT TO HELP PREVENT PERSONAL INJURY WHEN PERFORMING VEHICLE MAINTENANCE, REPAIR OR SERVICE.



CAUTION

PROCEDURES AND TOOLS

A TECHNICIAN USING A SERVICE PROCEDURE OR TOOL WHICH HAS NOT BEEN RECOMMENDED BY HENDRICKSON MUST FIRST SATISFY HIMSELF THAT NEITHER HIS SAFETY NOR THE VEHICLE'S SAFETY WILL BE JEOPARDIZED BY THE METHOD OR TOOL SELECTED. INDIVIDUALS DEVIATING IN ANY MANNER FROM THE INSTRUCTIONS PROVIDED WILL ASSUME ALL RISKS OF CONSEQUENTIAL PERSONAL INJURY OR DAMAGE TO EQUIPMENT INVOLVED.



WARNING

PARTS CLEANING

SOLVENT CLEANERS CAN BE FLAMMABLE, POISONOUS, AND CAUSE BURNS. TO HELP AVOID SERIOUS PERSONAL INJURY, CAREFULLY FOLLOW THE MANUFACTURER'S PRODUCT INSTRUCTIONS AND GUIDELINES AND THE FOLLOWING PROCEDURES:

1. WEAR PROPER EYE PROTECTION.
2. WEAR CLOTHING THAT PROTECTS YOUR SKIN.
3. WORK IN A WELL-VENTILATED AREA.
4. DO NOT USE GASOLINE OR SOLVENTS THAT CONTAIN GASOLINE. GASOLINE CAN EXPLODE.
5. ACIDIC SOLUTIONS CANNOT BE USED ON ALUMINUM COMPONENTS.
6. HOT SOLUTION TANKS OR ALKALINE SOLUTIONS MUST BE USED CORRECTLY. FOLLOW THE MANUFACTURER'S RECOMMENDED INSTRUCTIONS AND GUIDELINES CAREFULLY TO HELP PREVENT PERSONAL ACCIDENT OR INJURY.

DO NOT USE HOT SOLUTION TANKS OR WATER AND ALKALINE SOLUTIONS TO CLEAN GROUND OR POLISHED PARTS. DOING SO WILL CAUSE DAMAGE TO THE PARTS AND VOID WARRANTY.



WARNING

JACKING METHODS

IMPROPER JACKING METHODS CAN CAUSE STRUCTURAL DAMAGE AND RESULT IN LOSS OF VEHICLE CONTROL, SEVERE PERSONAL INJURY OR DEATH AND WILL VOID HENDRICKSON'S WARRANTY. REFER TO VEHICLE MANUFACTURER FOR PROPER JACKING INSTRUCTIONS.



WARNING

SUPPORT THE VEHICLE PRIOR TO SERVICING

DO NOT AT ANY TIME WORK AROUND OR UNDER A VEHICLE SUPPORTED ONLY ON LIFTING DEVICES. THE VEHICLE MUST BE SECURELY CHOCKED AND SUPPORTED ON RIGID STANDS OF SUFFICIENT STRENGTH BEFORE WORK MAY COMMENCE, FAILURE TO DO SO CAN CAUSE PERSONAL INJURY OR DAMAGE TO EQUIPMENT.

SECTION 4 Parts Lists

Mid Engine -2° Pinion Angle

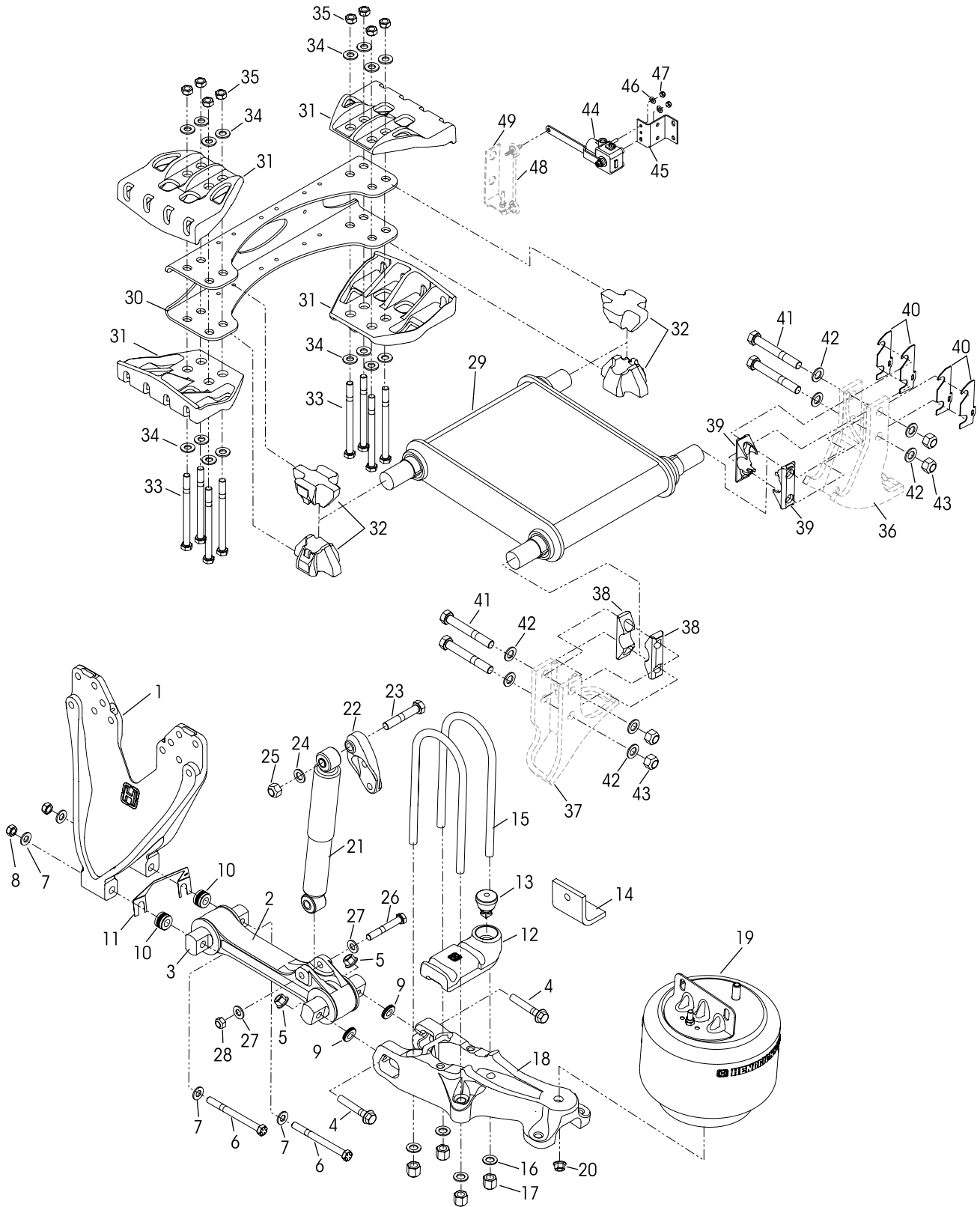



HTB® 210 for Spartan Motorhome Chassis – Mid Engine

KEY NO.	PART NO.	DESCRIPTION	NO.REQ.	KEY NO.	PART NO.	DESCRIPTION	NO.REQ.
1	65700-000	Frame Hanger	2	24	22962-001	3/4" Hardened Washer	2
2	66797-003	Torque Rod Assembly - 15.67", Includes Key No. 3	2	25	49842-000	3/4"-10 UNC Locknut	2
3	64664-000L 49176-018	*Torque Rod Bushing Torque Rod Fastener Service Kit, Axle Set, Includes Key Nos. 4-8	2	26	32043-005	5/8"-11 UNC 4.5" Lower Shock Bolt	2
4	66636-003	5/8"-11 UNC 4.0" Flange Bolt <i>Replaces 32043-008, 22962-004</i>	4	27	22962-004	5/8" Hardened Washer	4
5	66637-000	5/8"-11 UNC Flange Locknut <i>Replaces 47764-000, 22962-004</i>	4	28	47764-000	5/8"-11 UNC Locknut	2
6	32043-007	5/8"-11 UNC 7.0" Hex Bolt	4		66175-002	Torque Box Cross Member Assembly, Includes Key Nos. 29-35	1
7	22962-004	5/8" Hardened Washer	8	29	64785-005	Torque Box Assembly w/Bar Pin Bushing <i>Replaces 64785-004</i>	1
8	47764-000	5/8"-11 UNC Locknut	4	30	67478-000	Cross Member C-Channel <i>Replaces 64970-000</i>	1
9	66193-001	Pinion Spacer, Air Spring Bracket - 8 mm	4	31	66698-000	Cross Member Gusset	4
10	66193-003	Pinion Spacer, Frame Hanger - 24 mm	4	32	67233-000	Cross Member Bar Pin Clamp <i>Replaces 65144-000</i>	4
11		Torque Rod Shim	As Req.		66025-002	Cross Member Fastener Service Kit, Includes Key Nos. 33-35	
	65640-001	1/32" (0.030")		33	32043-016	5/8"-11 UNC 8.0" Bolt	8
	65640-002	1/16" (0.060")		34	22962-004	5/8" Hardened Washer	16
	65640-003	1/8" (0.120")		35	47764-000	5/8"-11 UNC Locknut	8
12	65708-000	Top Pad Assembly, Includes Key No. 13	2	36		**Axle Bracket (Long Arm Side)	1
13	64080-000	Axle Stop	2	37		**Axle Bracket (Short Arm Side)	1
14	66675-000 48718-115	Axle Stop Spacer Plate U-bolt Fastener Service Kit, Axle Set, Includes Key Nos. 15-17	2	38	66174-000	Axle Bracket Bar Pin Clamp, Non-Adjustable	2
15	64102-001	3/4"-16 UNF 13.5" U-bolt	4	39	66274-000	Axle Bracket Bar Pin Clamp, Adjustable	2
16	22962-001	3/4" Hardened Washer	8	40	65737-001	Axle Bracket Spacer - 0.093"	4
17	49685-000	3/4"-16 UNF U-bolt Locknut	8		66027-001	Axle Bracket Fastener Service Kit, Includes Key Nos. 41-43	
18		Lower Air Spring Bracket 2°-6° Pinion Angle		41	58917-003	3/4"-10 UNC 5.5" Bolt <i>Replaces 50764-002</i>	4
	65638-001	Right Hand	1	42	22962-001	3/4" Hardened Washer	8
	65638-002	Left Hand	1	43	49842-000	3/4"-10 UNC Locknut	4
19	66643-002L	Air Spring Assembly (FS) <i>Replaces 60977-002L</i>	2		57977-000	Height Control Valve Assembly, Includes Key Nos. 44-47	1
20	60819-000	1/2"-13 UNC Flange Nut <i>Replaces 17700-010, 22962-014</i>	2	44	60501-000	Height Control Valve	1
21	66153-005L	Shock Absorber	2	45	57975-000	HCV Mounting Bracket	1
22	67463-005	Shock Absorber Bracket <i>Replaces 65000-005</i>	2	46	22962-028	1/4" Hardened Washer	2
	50754-024	Shock Absorber Fastener Service Kit, Axle Set, Includes Key Nos. 23-28		47	49983-000	1/4"-20 UNC Locknut	2
23	50764-010	3/4"-10 UNC 4.25" Upper Shock Bolt	2	48		**HCV Linkage Assembly	1
				49		**Lower HCV Linkage Mounting Bracket	1
				Not shown	70867-001	P-80® Lubricant - 10 ml.	per Bushing 1

NOTE:

* HTB torque rod bushing replacement can be done using the Hendrickson Torque Rod Bushing Assembly Tool (Funnel) Part No. 66086-000.

** Not Supplied by Hendrickson, used for reference only. Refer to vehicle manufacturer for more information.



MM Rear Engine -4° Pinion Angle
MM Rear Engine -5° Pinion Angle

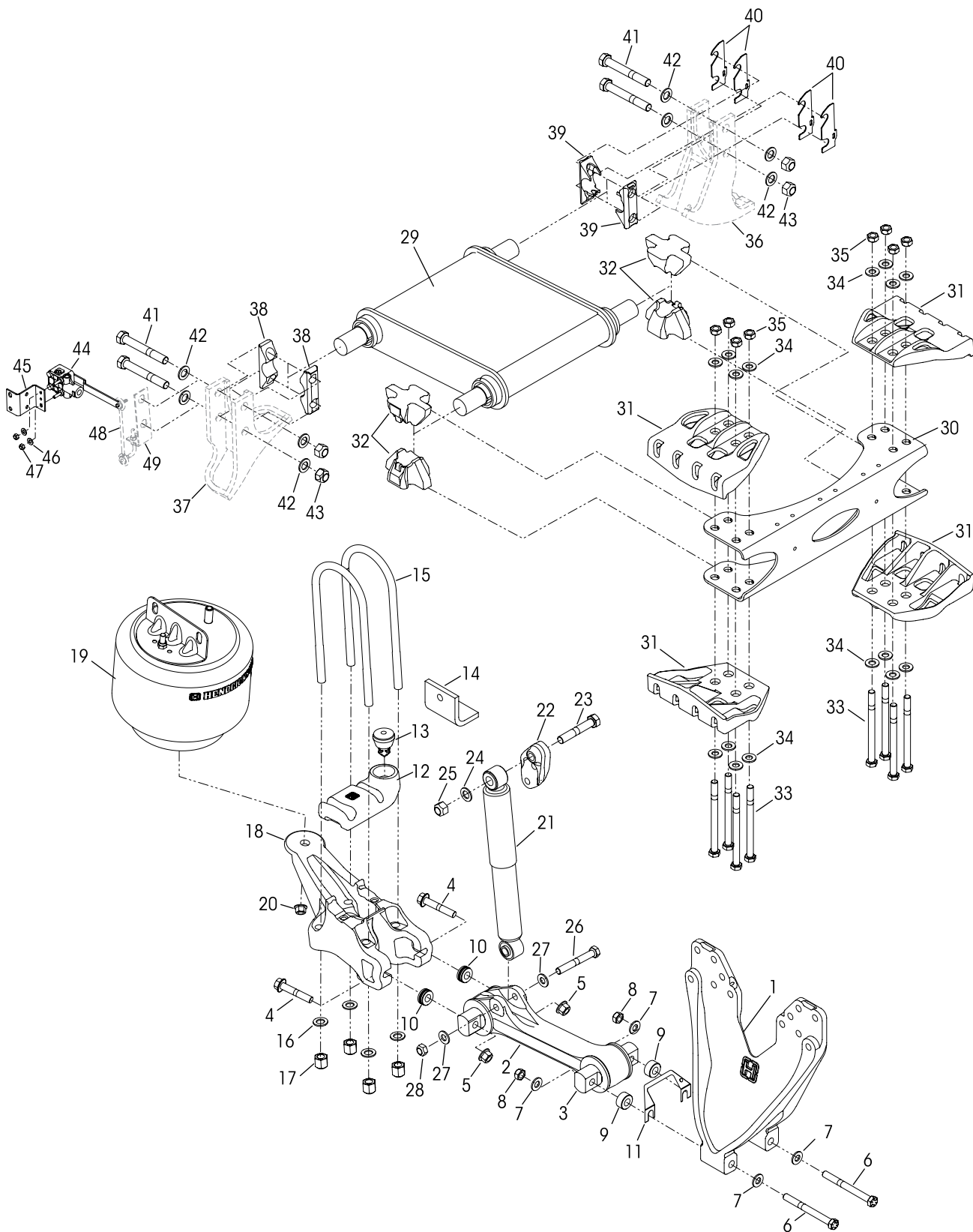



HTB® 210 for Spartan Motorhome Chassis – Rear Engine

KEY NO.	PART NO.	DESCRIPTION	NO.REQ.	KEY NO.	PART NO.	DESCRIPTION	NO.REQ.
1	65700-000	Frame Hanger	2		50754-024	Shock Absorber Fastener Service Kit, Axle Set , Includes Key Nos. 23-28	
2	66797-002	Torque Rod Assembly - 15.67", Includes Key No. 3	2	23	50764-010	3/4"-10 UNC 4.25" Upper Shock Bolt	2
3	64664-000L	*Torque Rod Bushing	2	24	22962-001	3/4" Hardened Washer	2
	49176-018	Torque Rod Fastener Service Kit, Axle Set , Includes Key Nos. 4-8	2	25	49842-000	3/4"-10 UNC Locknut	2
4	66636-003	5/8"-11 UNC 4.0" Flange Bolt <i>Replaces 32043-008, 22962-004</i>	4	26	32043-005	5/8"-11 UNC 4.5" Lower Shock Bolt	2
5	66637-000	5/8"-11 UNC Flange Locknut <i>Replaces 47764-000, 22962-004</i>	4	27	22962-004	5/8" Hardened Washer	4
6	32043-007	5/8"-11 UNC 7.0" Hex Bolt	4	28	47764-000	5/8"-11 UNC Locknut	2
7	22962-004	5/8" Hardened Washer	8		66175-002	Torque Box Cross Member Assembly, Includes Key Nos. 29-35	1
8	47764-000	5/8"-11 UNC Locknut	4	29	64785-005	Torque Box Assembly w/Bar Pin Bushing <i>Replaces 64785-004</i>	1
9		Pinion Spacer - Air Spring Bracket	4	30	67478-000	Cross Member C-Channel <i>Replaces 64970-000</i>	1
	66193-001	8 mm, MM -5° Pinion Angle		31	66698-000	Cross Member Gusset	4
	66193-002	16 mm, MM -4° Pinion Angle		32	67233-000	Cross Member Bar Pin Clamp <i>Replaces 65144-000</i>	4
10		Pinion Spacer - Frame Hanger	4		66025-002	Cross Member Fastener Service Kit , Includes Key Nos. 33-35	
	66193-002	16 mm, MM -5° Pinion Angle		33	32043-016	5/8"-11 UNC 8.0" Bolt	8
	66193-004	19.3 mm, MM -4° Pinion Angle		34	22962-004	5/8" Hardened Washer	16
11		Torque Rod Shim	As Req.	35	47764-000	5/8"-11 UNC Locknut	8
	65640-001	1/32" (0.030")		36		**Axle Bracket (Long Arm Side)	1
	65640-002	1/16" (0.060")		37		**Axle Bracket (Short Arm Side)	1
	65640-003	1/8" (0.120")		38	66174-000	Axle Bracket Bar Pin Clamp, Non-Adjustable	2
12	65708-000	Top Pad Assembly, Includes Key No. 13	2	39	66274-000	Axle Bracket Bar Pin Clamp, Adjustable	2
13	64080-000	Axle Stop	2	40	65737-001	Axle Bracket Spacer - 0.093"	4
14	66675-000	Axle Stop Spacer Plate	2		66027-001	Axle Bracket Fastener Service Kit , Includes Key Nos. 41-43	
	48718-116	U-bolt Fastener Service Kit, Axle Set , Includes Key Nos. 15-17		41	58917-003	3/4"-10 UNC 5.5" Bolt <i>Replaces 50764-002</i>	4
15	64102-002	3/4"-16 UNF 14.0" U-bolt	4	42	22962-001	3/4" Hardened Washer	8
16	22962-001	3/4" Hardened Washer	8	43	49842-000	3/4"-10 UNC Locknut	4
17	49685-000	3/4"-16 UNF U-bolt Locknut	8		57977-000	Height Control Valve Assembly, Includes Key Nos. 44-47	1
18		Lower Air Spring Bracket 8°-10° Pinion Angle		44	60501-000	Height Control Valve	1
	65698-001	Right Hand	1	45	57975-000	HCV Mounting Bracket	1
	65698-002	Left Hand	1	46	22962-028	1/4" Hardened Washer	2
19	66643-002L	Air Spring Assembly (FS) <i>Replaces 60977-002L</i>	2	47	49983-000	1/4"-20 UNC Locknut	2
20	60819-000	1/2"-13 UNC Flange Nut <i>Replaces 17700-010, 22962-014</i>	2	48		**HCV Linkage Assembly	1
21	66153-005L	Shock Absorber	2	49		**Lower HCV Linkage Mounting Bracket	1
22	67463-005	Shock Absorber Bracket <i>Replaces 65000-005</i>	2	Not shown	70867-001	P-80® Lubricant - 10 ml. per Bushing	1

NOTE:

* HTB torque rod bushing replacement can be done using the Hendrickson Torque Rod Bushing Assembly Tool (Funnel) Part No. 66086-000.

** Not Supplied by Hendrickson, used for reference only. Refer to vehicle manufacturer for more information.



Drive Tag

K2 Rear Engine -2°, -3.5° Pinion Angle

MM Rear Engine -4° Pinion Angle

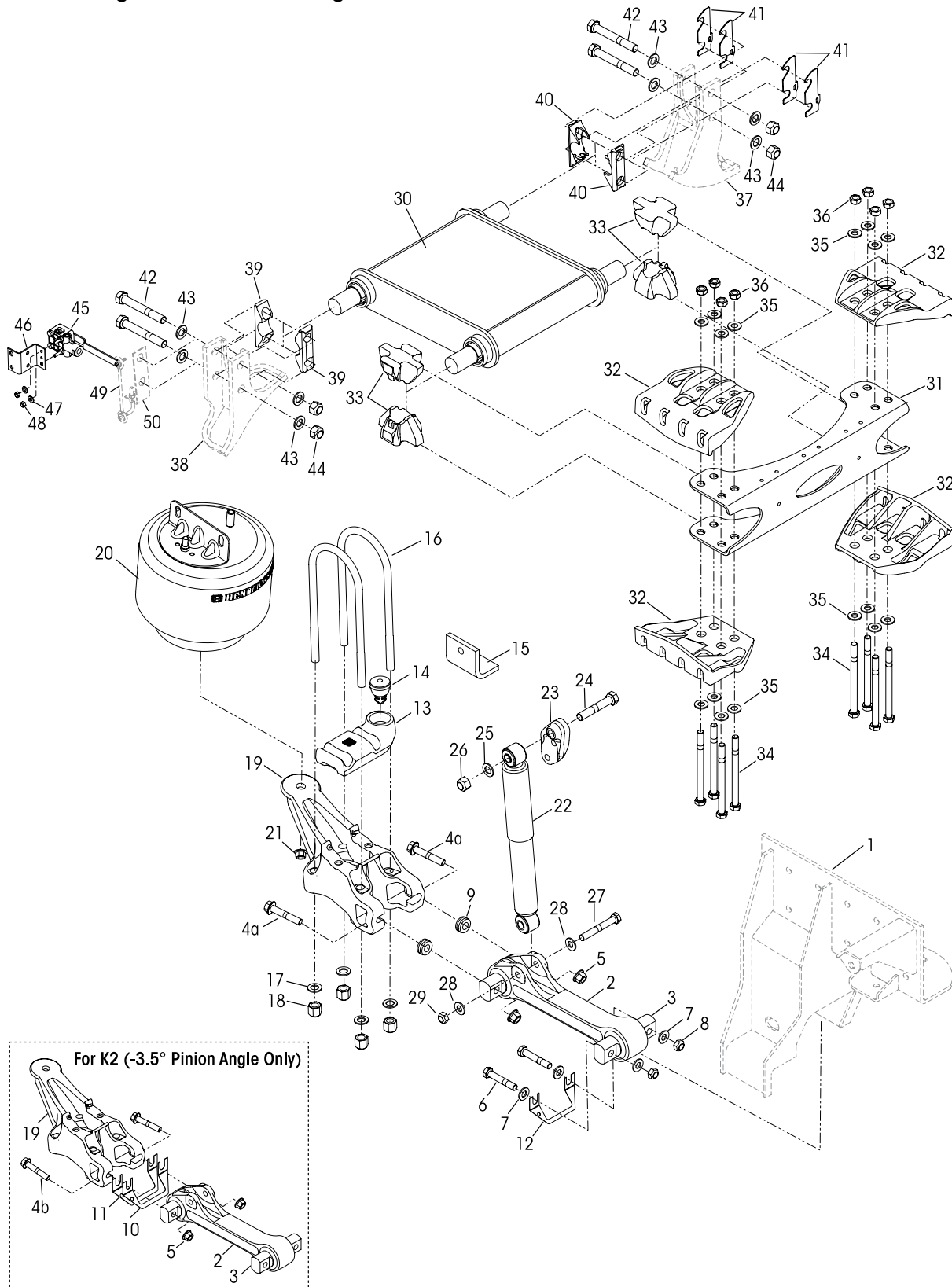



HTB® 210 for Spartan Motorhome Chassis – Drive Tag

KEY NO.	PART NO.	DESCRIPTION	NO.REQ.	KEY NO.	PART NO.	DESCRIPTION	NO.REQ.
1		*Frame Hanger	2		50754-024	Shock Absorber Fastener Service Kit, Axle Set , Includes Key Nos. 24-29	
2	66797-001	Torque Rod Assembly - 15.67", Includes Key No. 3	2	24	50764-010	¾"-10 UNC 4.25" Upper Shock Bolt	2
3	64664-000L	**Torque Rod Bushing	2	25	22962-001	¾" Hardened Washer	2
		Torque Rod Fastener Service Kit, Axle Set		26	49842-000	¾"-10 UNC Locknut	2
	49176-029	K2 -2°, Includes Key Nos. 4a, 5-8		27	32043-005	5/8"-11 UNC 4.5" Lower Shock Bolt	2
	49176-037	MM -4°, K2 -3.5°, Includes Key Nos. 4b, 5-8		28	22962-004	5/8" Hardened Washer	4
4		5/8"-11 UNC Flange Bolt	4	29	47764-000	5/8"-11 UNC Locknut	2
a	66636-003	K2 -2°, 4.0", Replaces 32043-008, 22962-004			66175-002	Torque Box Cross Member Assembly, Includes Key Nos. 30-36	1
b	66636-004	MM -4°, K2 -3.5°, 3.5"		30	64785-005	Torque Box Assembly w/Bar Pin Bushing Replaces 64785-004	1
5	66637-000	5/8"-11 UNC Flange Locknut Replaces 47764-000, 22962-004	4	31	67478-000	Cross Member C-Channel Replaces 64970-000	1
6	32043-009	5/8"-11 UNC 3.5" Hex Bolt	4	32	66698-000	Cross Member Gusset	4
7	22962-004	5/8" Hardened Washer	8	33	67233-000	Cross Member Bar Pin Clamp Replaces 65144-000	4
8	47764-000	5/8"-11 UNC Locknut	4		66025-002	Cross Member Fastener Service Kit , Includes Key Nos. 34-36	
9	66193-002	Air Spring Bracket Pinion Spacer K2 (-2.0° Pinion Angle ONLY), 16 mm	4	34	32043-016	5/8"-11 UNC 8.0" Bolt	8
		Air Spring Bracket Pinion Shim		35	22962-004	5/8" Hardened Washer	16
10	65640-001	K2 (-3.5° Pinion Angle ONLY), 1/32" (0.030")	2	36	47764-000	5/8"-11 UNC Locknut	8
11	65640-003	K2 (-3.5° Pinion Angle ONLY), 1/8" (0.120")	2	37		***Axle Bracket (Long Arm Side)	1
12		Torque Rod Shim	As Req.	38		***Axle Bracket (Short Arm Side)	1
	65640-001	1/32" (0.030")		39	66174-000	Axle Bracket Bar Pin Clamp, Non-Adjustable	2
	65640-002	1/16" (0.060")		40	66274-000	Axle Bracket Bar Pin Clamp, Adjustable	2
	65640-003	1/8" (0.120")		41	65737-001	Axle Bracket Spacer - 0.093"	4
13	65708-000	Top Pad Assembly, Includes Key No. 14	2		66027-001	Axle Bracket Fastener Service Kit , Includes Key Nos. 42-44	
14	64080-000	Axle Stop	2	42	58917-003	¾"-10 UNC 5.5" Bolt Replaces 50764-002	4
15	66675-000	Axle Stop Spacer Plate	2	43	22962-001	¾" Hardened Washer	8
	48718-116	U-bolt Fastener Service Kit, Axle Set , Includes Key Nos. 16-18		44	49842-000	¾"-10 UNC Locknut	4
16	64102-002	¾"-16 UNF 14.0" U-bolt	4		57977-000	Height Control Valve Assembly, Includes Key Nos. 45-48	1
17	22962-001	¾" Hardened Washer	8	45	60501-000	Height Control Valve	1
18	49685-000	¾"-16 UNF U-bolt Locknut	8	46	57975-000	HCV Mounting Bracket	1
19		Lower Air Spring Bracket 8°-10° Pinion Angle		47	22962-028	¼" Hardened Washer	2
	65698-001	Right Hand	1	48	49983-000	¼"-20 UNC Locknut	2
	65698-002	Left Hand	1	49		***HCV Linkage Assembly	1
20	66643-002L	Air Spring Assembly (FS) Replaces 60977-002L	2	50		***Lower HCV Linkage Mounting Bracket	1
21	60819-000	½"-13 UNC Flange Nut Replaces 17700-010, 22962-014	2	Not shown	70867-001	P-80® Lubricant - 10 ml.	per Bushing 1
22	66153-005L	Shock Absorber	2				
23	67463-005	Shock Absorber Bracket Replaces 65000-005	2				

NOTE:

* Supplied by Hendrickson Auxiliary Axle Systems. See page 14 for Auxiliary Axle Parts List.

** HTB torque rod bushing replacement can be done using the Hendrickson Torque Rod Bushing Assembly Tool (Funnel) Part No. 66086-000.

*** Not Supplied by Hendrickson, used for reference only. Refer to vehicle manufacturer for more information.

The components illustrated on this page are supplied by Hendrickson Auxiliary Axle Systems. For information regarding component replacement or technical service call **1-800-660-2829**.

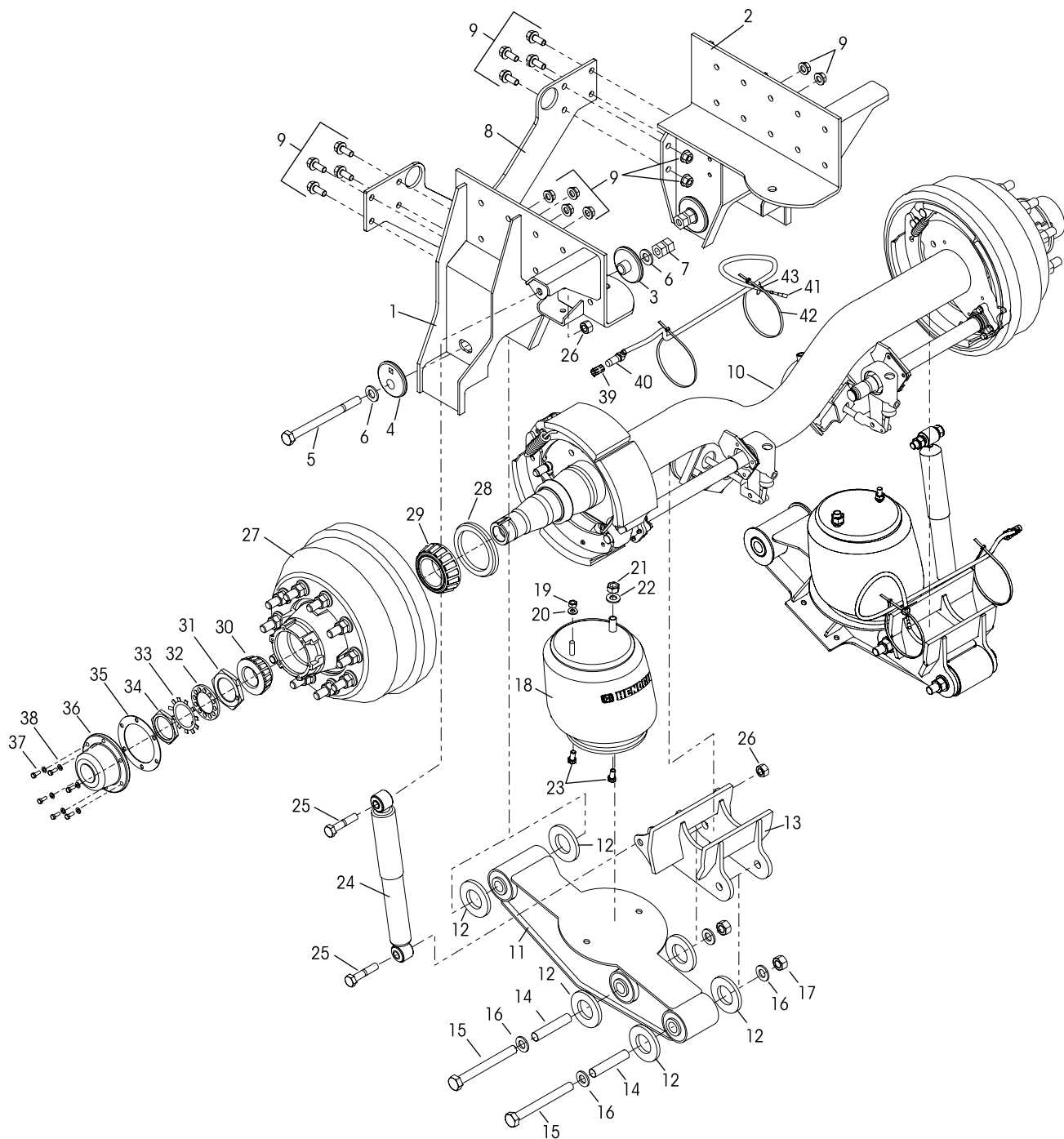



Auxiliary Axle Drive Tag for Spartan Motorhome Chassis

KEY NO.	PART NO.	DESCRIPTION	NO.REQ.	KEY NO.	PART NO.	DESCRIPTION	NO.REQ.
1	006974-1	Hanger Bracket Assembly (Driver's Side)	1	19	006908-1	1/2"-13 UNC Hex Nut	1
2	006974-2	Hanger Bracket Assembly (Passenger's Side)	1	20	006909-2	1/2" Lockwasher	1
	R-A-21116	QUIK-ALIGN® Front Pivot Bolt Kit, Includes Key Nos. 3-7	2	21	006908-4	3/4"-16 UNF Hex Nut	1
3	C-20924	Flanged Concentric Inboard Washer	1	22	006909-3	3/4" Lockwasher	1
4	C-20925	Flanged Eccentric Washer	1	23	006907-1	1/2"-13 UNC 1.0" Hex Bolt	2
5	002548-1	7/8"-9 UNC 10.0" Heavy Hex Screw	1	24	006797	Shock Absorber	2
6	A-21024	Hardened Steel Washer	2		006921	Shock Absorber Bolt Kit (DTSM) (Zinc), Includes Key Nos. 25-26	2
7	A-15122	QUIK-ALIGN Service Nut	1	25	006907-3	3/4"-10 UNC 3.5" HHB	2
8	006993	Cross Member, 34.25" F.W.	1	26	006908-3	3/4"-10 UNC Hex Nut	2
9	006912	Cross Member Bolt Kit	1	27	003053	Hub / Drum ST20/22/UH/OUT/10/ABS	2
	006723	Axle Beam Assembly, Includes Key Nos. 10-13	1		006914	Wheel End Components Kit, Includes Key Nos. 28-38	1
10	006742	Axle - 6.0" Drop, 6.5" x 6.0" Brakes	1	28	A-11571	Hub Seal	2
11		Beam Assembly		29	A-2717	Inner Bearing Cone	2
	006927-1	Driver's Side	1	30	A-2718	Outer Bearing Cone	2
	006927-2	Passenger's Side	1	31	A-1985	Inner Wheel Bearing Adj. Nut	1
12	B-14495	Wear Pad	12	32	A-1987	Axle Lockwasher - Pin Type	1
13		*Axle Seat Weldment (DTSM)	1	33	002653	Star Washer	1
		*Axle Seat Weldment (DTSM)	1	34	A-1986	Outer Wheel Bearing Nut	1
	006932	Axle Seat Bolt Kit, Includes Key Nos. 14-17	2	35	A-1973	Hubcap Gasket	2
14	002520	Plastic Liner	2	36	003520	Hubcap Assembly w/Pipe Plug & Cap Plug	2
15	006907-4	7/8"-9 UNC Heavy Hex Bolt	2	37	SA-1100-4	5/16"-18 UNC Hex Head Bolt	12
16	006909-4	7/8" Washer	4	38	SA-1600-7	5/16" Lockwasher	12
17	006908-5	7/8"-9 UNC Hex Nut	2	39	006924	ABS Sensor Clip	2
18	006994	Air Spring (Ride)	2	40	006910	ABS Sensor	2
	006913	Air Spring Bolt Kit (Zinc), Includes Key Nos. 19-23	2	41	006929	ABS Conduit Sleeve	2
				42	006897	Cable Tie, Heavy Duty	4
				43	006969	Cable Tie, Light Duty	2

NOTE:

The components listed on this page are supplied by Hendrickson Specialty Products Auxiliary Axle Systems. For information regarding component replacement or technical service call **1-800-660-2829**.

* Axle seat brackets are welded to axle tube. Part not serviceable.

SECTION 5 Special Tools

TORQUE ROD BUSHING TOOLS

TORQUE ROD BUSHING ASSEMBLY TOOL (FUNNEL)

Contact your authorized Hendrickson distributor to order the bushing funnel tool, Hendrickson Part Number 66086-000.



TORQUE ROD BUSHING RECEIVING TOOL

This shop made tool is designed for the torque rod bushing replacement. Bushing tools are made from cold rolled steel or equivalent. Drawing is for reference only.

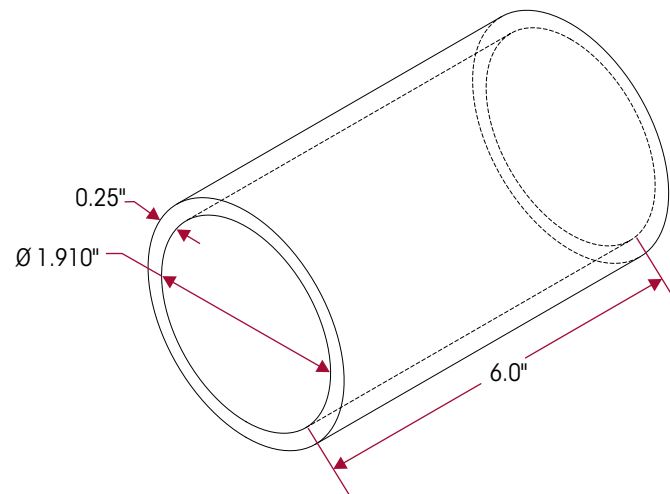

SECTION 6

Preventive Maintenance

COMPONENT INSPECTION

A visual inspection of the suspension is necessary every 10,000 miles or annually, whichever comes first, to help ensure all such components function to their highest efficiency. Visual Inspection must include the following items and other components referenced in this section.

- **Air Spring** — Inspect air springs for chafing or any signs of air spring or component damage. Ensure that the upper bead plate is tight against the underside of the frame. Check for any lateral slippage at the lower air spring bracket. Slippage of $\frac{1}{8}$ " in either direction is acceptable. Replace all worn or damaged parts.
- **Air Spring Bracket** — Check the overall condition of the upper and lower air spring brackets for dents, dings, cracks or other damage. Check for any signs of looseness in the clamp group. Check all fasteners for proper torque. Replace all worn or damaged parts.
- **Cross Member and Gussets** — Inspect the cross member and gussets for any signs of loosening or damage. Inspect the bar pin clamp blocks for any signs of looseness or movement. Check all fasteners for proper torque. Replace all worn or damaged parts.

NOTE

Hendrickson recommends the use of Grade 8 bolts with hardened flat washers and Grade C locknuts for all suspension component attachments. Washers are not necessary when flange head fasteners are used.

- **Fasteners** — Look for any loose or damaged fasteners on the entire suspension. Make sure all fasteners are tightened to a torque value within the specified torque range. See Torque Specification Section of this publication for Hendrickson recommended torque requirements. Use a calibrated torque wrench to check torque in the tightening direction. As soon as the fastener starts to move, record the torque. Correct the torque if necessary. Replace any worn or damaged fasteners.
- **Frame Hanger Bracket** — Inspect the frame hanger bracket for any signs of loosening or damage. Inspect all fasteners securing the frame hanger bracket to the frame rails as well as the longitudinal torque rod mounting fasteners. Check all fasteners for proper torque. Replace all worn or damaged parts.
- **Height Control Valve and Air Lines** — Check the suspension air system for air leaks. Check all air lines for proper routing. Check for chafing or pinched air lines. Check the height control valve linkage for damage or interference with peripheral components. Replace all worn or damaged parts.
- **Shock Absorbers** — Look for any signs of dents or leakage. Misting is not considered a leak. See Shock Absorber Inspection in this section.
- **Tire Wear** — Inspect the tires for wear patterns that may indicate suspension damage or misalignment. Replace all worn or damaged parts. Verify proper alignment and correct as necessary.
- **Top Pad and Rubber Axle Stop** — Look for cracks and/or missing rubber axle stops. The rubber axle stop is exposed to contact forces in extreme jounce conditions. It will be necessary to visually inspect the rubber axle stop for wear at the specified inspection interval. The rubber axle stop must be replaced when the contact rubber is worn down to a $\frac{1}{16}$ " above the bump stop pedestal. See the Component Replacement Section of this publication for replacement.
- **Wear and Damage** — Inspect all parts of the suspension for wear and damage. Look for bent or cracked parts. Replace all worn or damaged parts.

U-BOLT LOCKNUTS

1. U-bolt locknuts must be re-torqued to specification at preparation for delivery.
2. U-bolt locknuts must be re-torqued at 500 miles or first service interval.
3. Thereafter, follow annual or 10,000 mile inspection and re-torque interval.

NOTE

Current Hendrickson Truck Suspension Systems U-bolt clamp group hardware for the HTB 210 suspension are $\frac{3}{4}$ "-16 UNF Grade C high locknuts with hardened flat washers and $\frac{3}{4}$ "-16 UNF Grade 8 U-bolts that are phosphate and oil coated.

Tighten the U-bolt locknuts evenly in 50 foot pound increments to 325-375 foot pounds torque in the proper pattern to achieve uniform bolt tension as shown in Figure 6-1.

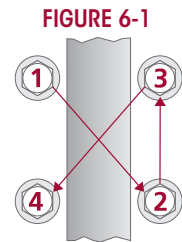

WARNING

IT IS IMPORTANT THAT THE U-BOLT CLAMP GROUP CONNECTION BE PROPERLY ALIGNED AND HAVE THE PROPER TIGHTENING TORQUE VALUES MAINTAINED. METAL SURFACES CAN WORK AND WEAR AGAINST OTHER RELATED CLAMP GROUP COMPONENTS IF NOT PROPERLY ALIGNED OR PROPERLY TIGHTENED TO MAINTAIN THE PROPER CLAMP FORCE. FAILURE TO DO SO CAN CAUSE PREMATURE COMPONENT WEAR, POSSIBLE SEPARATION OF THE CLAMP GROUP, CAUSING LOSS OF VEHICLE CONTROL, PROPERTY DAMAGE, OR PERSONAL INJURY, SEE FIGURE 6-2.

TORQUE BOX

It is important to inspect the torque box during preventive maintenance service. Visually inspect the torque box for cracks, damage, torn or shredded rubber, or any signs of looseness at the bar pin clamps. Replace all worn or damaged parts. The torque box is a non-serviceable item and must be replaced as an assembly, if damaged, or the bushings are worn out. Check all fasteners for proper torque, see Torque Specifications Section of this publication.

LATERAL ALIGNMENT INSPECTION

The torque box maintains lateral alignment of the drive axles and controls axle walkout during cornering. If the lateral alignment of the drive axles is incorrect, it may be necessary to align the torque box and/or the axle. See Lateral Alignment in the Alignment & Adjustments Section of this publication.

FIGURE 6-2

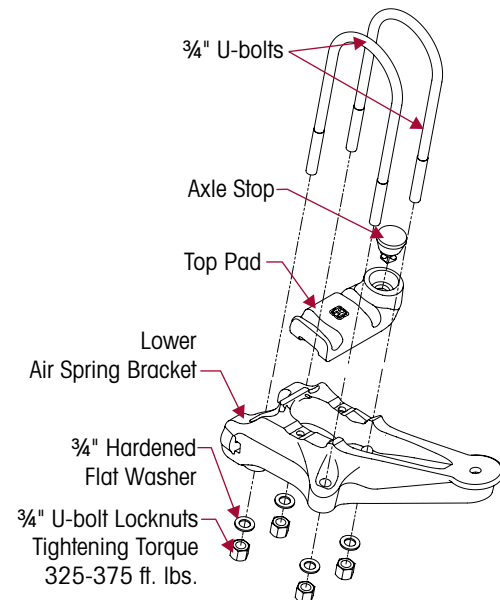

AXLE BRACKETS

Due to the importance of maintaining a proper connection between the axle housing and axle brackets, the axle brackets and axle housing require visual inspection. If the axle brackets show excessive wear, or the welds have cracks, the components will need to be repaired or replaced. If repair is needed, contact the vehicle or axle manufacturer for approved repair procedures.

1. Inspect the axle brackets for signs of excessive wear. Check the welds for signs of cracking, see Figure 6-3.
2. Inspect the axle bracket to axle weld for signs of cracking, see Figure 6-3.

FIGURE 6-3

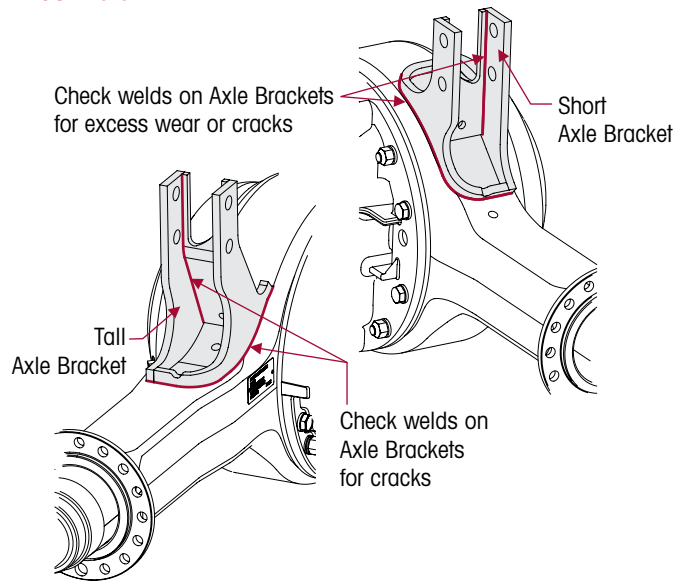

LONGITUDINAL TORQUE RODS

The longitudinal torque rods, air spring brackets, pinion spacers (if equipped), and the torque box, maintain driveline angles while controlling acceleration, cornering, and braking forces. All torque rods and mounting hardware should be inspected for damage and proper fastener torque every 10,000 miles or annually. Follow the vehicle manufacturer's specifications for tightening torque values.

DANGER

THE AIR SPRING TRANSFERS LOAD TO THE FRAME HANGER THROUGH THE LONGITUDINAL TORQUE ROD. PRIOR TO LONGITUDINAL TORQUE ROD REMOVAL THE SUSPENSION AIR SYSTEM MUST BE DEFLATED. FAILURE TO DO SO WILL CAUSE THE AXLE TO VIOLENTLY SHIFT, RESULTING IN POSSIBLE DAMAGE TO COMPONENTS AND/OR PERSONAL INJURY.

INSPECTION

1. Chock the wheels.
2. Support the frame.

WARNING

PRIOR TO AND DURING DEFLATION AND INFLATION OF THE AIR SUSPENSION SYSTEM, ENSURE THAT ALL PERSONNEL AND EQUIPMENT ARE CLEAR FROM UNDER THE VEHICLE AND AROUND THE SERVICE AREA, FAILURE TO DO SO CAN CAUSE SERIOUS PERSONAL INJURY, DEATH, OR PROPERTY DAMAGE.

3. See additional Air Spring Warnings and Instructions in the Important Safety Notice Section of this publication prior to deflating or inflating the suspension system.
4. Disconnect the height control linkage assembly from the height control valve arm. Lower the height control valve arm to exhaust the air in the air springs and deflate the rear suspension, see vehicle manufacturer's instructions.
5. Visually inspect the following:
 - a. Torque rods for cracks, bends, breaks, or end hubs which are elongated or oval. Any of these conditions require torque rod replacement.
 - b. Torque rod bushings for torn or shredded rubber. Any of these conditions require torque rod bushing replacement.

- c. The torque rod assembly for movement while applying pressure with a long pry bar to each torque rod end. If movement is detected, replace torque rod bushings and/or torque rod as required.
To replace the torque rod, or the torque rod bushings, see the Component Replacement Section of this publication.
6. Inflate the suspension by raising the height control valve arm.
7. Reconnect the height control linkage assembly to the height control valve arm by sliding the rubber grommet onto the stud.
8. Remove the frame supports.
9. Remove the wheel chocks.
10. Verify the vehicle is at the correct ride height. Correct as necessary. Refer to Ride Height Adjustment in the Alignment & Adjustment section of this publication.

AIR FITTING INSPECTION

1. If an air leak is suspected, begin by building up the air system to normal operating pressure.
2. Spray all nylon tube air fittings with a soapy water solution to detect the leak location.

NOTE

Air lines and fittings may be inspected for leaks using a soapy water solution. The height control valve, however, cannot be inspected using this method. All height control valves have an allowable leakage rate. The only acceptable method for inspection of the height control valves is the height control valve test found in this section.

3. If an air leak is located, ensure the tubing end is clean and in good condition and the end is cut square. Check to see if the tubing is binding, being pulled upon or bent.
4. Visually inspect the air fittings for signs of damage or contamination.

SHOCK ABSORBER INSPECTION

Hendrickson uses a long service life, premium shock absorber on all HTB 210 suspensions. If shock absorber replacement is necessary, Hendrickson recommends that the shock absorbers be replaced with identical  Hendrickson Genuine parts for servicing. Failure to do so will affect the suspension performance, durability, and will void the warranty.

Inspection of the shock absorber can be performed by doing a heat test, and a visual inspection. For instructions on shock absorber replacement see the Component Replacement Section of this publication. It is not necessary to replace shock absorbers in pairs if one shock absorber requires replacement.

HEAT TEST

1. Drive the vehicle at moderate speeds on rough road for a minimum of fifteen minutes.

FIGURE 6-9



WARNING

DO NOT GRAB THE SHOCK AS IT COULD POSSIBLY CAUSE PERSONAL INJURY.

2. Use an infrared thermometer to check the temperature of the shock absorber. This can also be performed by carefully touching the shock body below the dust cover. Touch the frame to get an ambient reference, see Figure 6-9. A warm shock absorber is acceptable, a cold shock absorber should be replaced.
3. To inspect for an internal failure, remove and shake the suspected shock. Listen for the sound of metal parts rattling inside. Rattling of metal parts can indicate that the shock has an internal failure.

VISUAL INSPECTION

Look for these potential problems when doing a visual inspection. Inspect the shock absorbers fully extended. Replace as necessary.

FIGURE 6-10



LEAKING VS. MISTING SHOCK VISUAL INSPECTION

The inspection must not be conducted after driving in wet weather or a vehicle wash. Shocks needs to be free from water. Many shocks are often misdiagnosed as failures. Misting is the process whereby very small amounts of shock fluid evaporate at a high operating temperature through the upper seal of the shock. When the "mist" reaches the cooler outside air, it condenses and forms a film on the outside of the shock body. Misting is perfectly normal and necessary function of the shock. The fluid which evaporates through the seal area helps to lubricate and prolong the life of the seal.

A shock that is truly leaking and needs to be replaced will show signs of fluid leaking in streams from the upper seal. These streams can easily be seen when the shock is fully extended, underneath the main body (dust cover) of the shock. Look for these potential problems when doing a visual inspection. Inspect the shock absorbers fully extended. Replace as necessary.

NOTE

The HTB 210 suspension is equipped with a premium seal on the shock, however this seal will allow for misting to appear on the shock body (misting is not a leak and is considered acceptable).

FIGURE 6-11



If the shock is damaged, install new shock absorber and replace as detailed in the Component Replacement Section of this publication.

SECTION 7

Alignment & Adjustments

RIDE HEIGHT ADJUSTMENT

The HTB 210 suspension is equipped with a height control valve mounted on the inside of the frame rail. Please refer to the Plumbing Diagram Section of this publication.

1. Use a work bay with a level surface.
2. Relax the suspension by slowly moving the vehicle back and forth several times in a straight line without using the brakes. This will slacken or loosen the suspension as the vehicle is positioned. End with all wheels positioned straight ahead. Do not set the parking brake.
3. Chock the front wheels of the vehicle.
4. When checking or adjusting ride height, verify and maintain the vehicle's air system is at full operating pressure.

**WARNING**

PRIOR TO AND DURING DEFLATION AND INFLATION OF THE AIR SUSPENSION SYSTEM, ENSURE ALL PERSONNEL AND EQUIPMENT ARE CLEAR FROM UNDER THE VEHICLE AND AROUND THE SERVICE AREA, FAILURE TO DO SO CAN CAUSE SERIOUS PERSONAL INJURY, DEATH, OR PROPERTY DAMAGE.

5. See additional Air Spring Cautions and Warnings in the Important Safety Notice Section of this publication prior to deflating or inflating the suspension system.

NOTE

It is important the height control valve is cycled completely before and after any ride height adjustments. The cycling will help make the adjustment more accurate.

6. Cycle the suspension using method **A** or **B**.

METHOD A — If equipped with a suspension dump system

Cycle the suspension air system by using the cab dump valve. Completely exhaust air from the suspension system. Inflate the suspension air system and allow several minutes for the suspension to stabilize prior to measuring suspension ride height.

METHOD B

Disconnect the height control linkage assembly from the height control valve arm. Lower the height control valve arm to exhaust the air in the air springs and deflate the rear suspension, see vehicle manufacturer's instructions. Reconnect the height control valve arm to the height control valve linkage assembly to inflate the suspension. Allow several minutes for the suspension to stabilize, see Figure 7-1.

7. Measure the vehicle ride height by using Method **C** or **D**.

METHOD C — Reference ride height measuring shock absorber length.

- a. Using a tape measure, measure the referenced ride height on the drive axle from the centerline of the upper shock mounting bolt to the centerline of the lower shock mounting bolt.

FIGURE 7-1

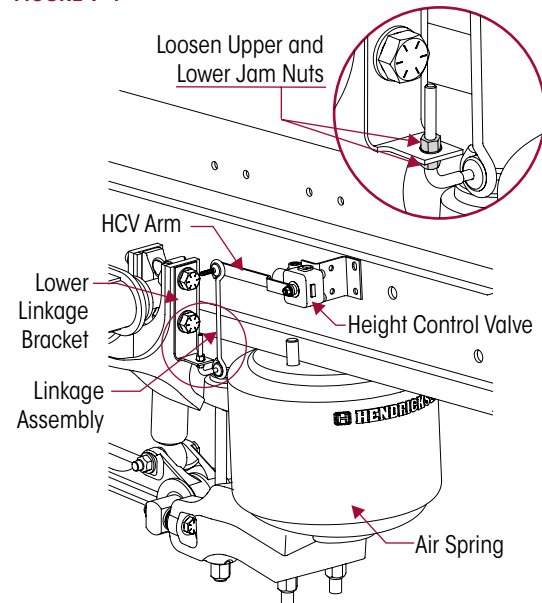

- b. Compare the referenced ride height measurement to the appropriate dimension "C" in Table 7-1.
- c. If the ride height is not within this range the ride height will need to be corrected.

Vehicle	"C" Shock Length (Referenced Ride Height)	"D" Design Ride Height
Rear Engine (Figure 7-2)	$18\frac{3}{16}'' \pm \frac{1}{8}''$	$8\frac{1}{2}'' \pm \frac{1}{8}''$
Mid Engine (Figure 7-3)	$18\frac{5}{8}'' \pm \frac{1}{8}''$	
Drive Tag (MM)	$19'' \pm \frac{1}{8}''$	
Drive Tag (K2)	$19\frac{5}{8}'' \pm \frac{1}{8}''$	

METHOD D — Design ride height

- a. Measure from the bottom of the axle stop spacer to the axle centerline.
- b. The design ride height dimension should be $8\frac{1}{2}'' \pm \frac{1}{8}''$, see dimension "D" in Figures 7-2 and 7-3)
- c. If the ride height is not within this range the ride height will need to be corrected.

NOTE

If an adjustment is required, verify and maintain the air system at full operating pressure.

FIGURE 7-2

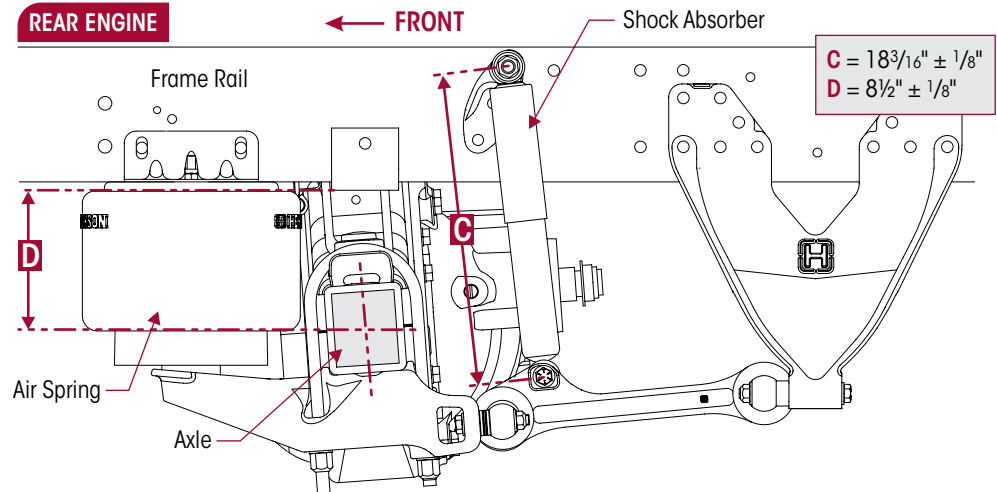
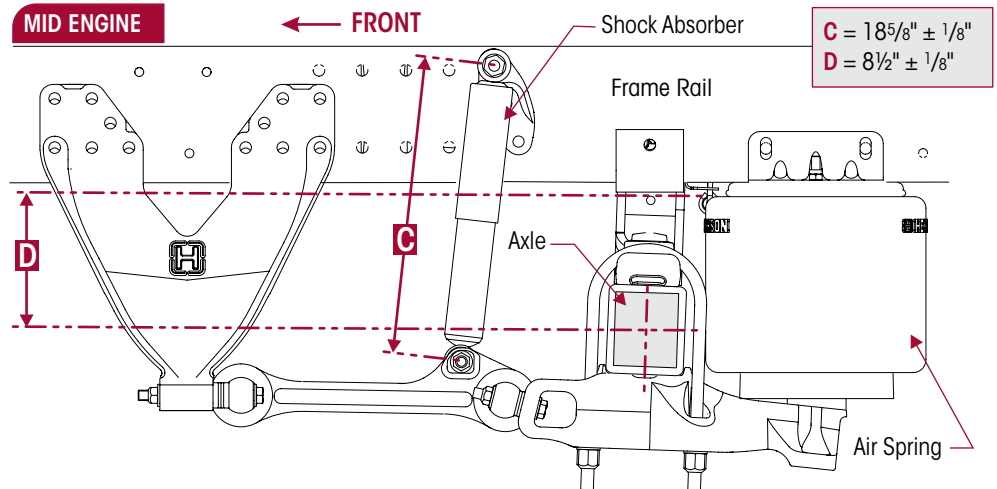
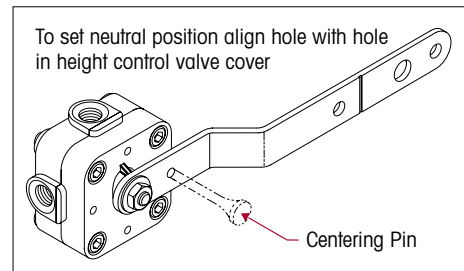

FIGURE 7-3



8. See additional Air Spring Warnings and Instructions in the Important Safety Notice Section of this publication prior to deflating or inflating the suspension system.
9. Disconnect the height control linkage assembly from the height control valve arm. Lower the height control valve arm to exhaust the air in the air springs and deflate the rear suspension, (See vehicle manufacturer's instructions).

FIGURE 7-4



10. Refill the suspension by raising the height control valve arm by hand until the suspension is at the proper ride height.
11. To set neutral position, use a wooden centering dowel (golf tee) in the alignment hole and engage in housing slot, as shown in Figure 7-4. **DO NOT** use a metal rod or nail as this may cause damage to the height control valve.
12. Loosen upper and lower jam nuts located on the lower linkage bracket, until the linkage rod can move up and down freely, see Figure 7-1.
13. Adjust the linkage assembly until it can be connected to the valve arm.
14. Tighten the upper and lower jam nuts to the vehicle manufacturer's specifications, see Figure 7-1.
15. Remove the wooden centering dowel (golf tee) from the height control valve.

NOTE The cycling of the height control valve will help make the adjustment more accurate. Be sure to maintain full system air pressure while setting or inspecting ride height.

NOTE During cycle operation of the height control valve it is normal to experience a limited amount of exhaust noise.

16. Cycle the suspension air system using **Method A** or **Method B** as detailed in Step 6.
17. Recheck the ride height.
18. Repeat Steps 8 through 17 until the ride height is within specification.

AXLE ALIGNMENT AND ADJUSTMENTS

ALIGNMENT

Checking and correcting alignment of the drive and tag axle involves performing the following steps in the sequence listed.

STEP	DESCRIPTION	COMMENTS
A	Preparing the vehicle	
B	Measuring the lateral alignment of the torque box	
C	Correcting torque box lateral alignment	(if necessary)
D	Measuring the lateral alignment of the axle	
E	Correcting lateral alignment of the axle	(if necessary)
F	Measuring axle thrust angle	
G	Correcting axle thrust angle	(if necessary)
H	Final torque of the drive axle	(if adjustments were made)
I	Measuring auxiliary axle alignment	
J	Correcting auxiliary axle alignment	(if necessary)

STEP A. PREPARING THE VEHICLE

- A-1. Use a work bay with a level surface.
- A-2. Relax the suspension by slowly moving the vehicle back and forth several times in a straight line without using the brakes. This will slacken or loosen the suspension as the vehicle is positioned. End with all wheels positioned straight ahead.
- A-3. **DO NOT** set the parking brake. Consult the vehicle manufacturer for parking brake override procedure. Chock the front wheels of the vehicle.
- A-4. Verify and maintain the air system at full operating pressure.
- A-5. Verify the vehicle is at the correct ride height. Correct as necessary. Refer to Ride Height Adjustment in this section.
- A-6. Verify all suspension components are in good condition. Repair or replace any worn or damaged suspension components before proceeding with the alignment process.
- A-7. Ensure all drive axle tires are the same size.
- A-8. Ensure all auxiliary axle drive tag tires are the same size.

STEP B. MEASURING TORQUE BOX LATERAL ALIGNMENT (See Figure 7-6)

FIGURE 7-6

REAR ENGINE

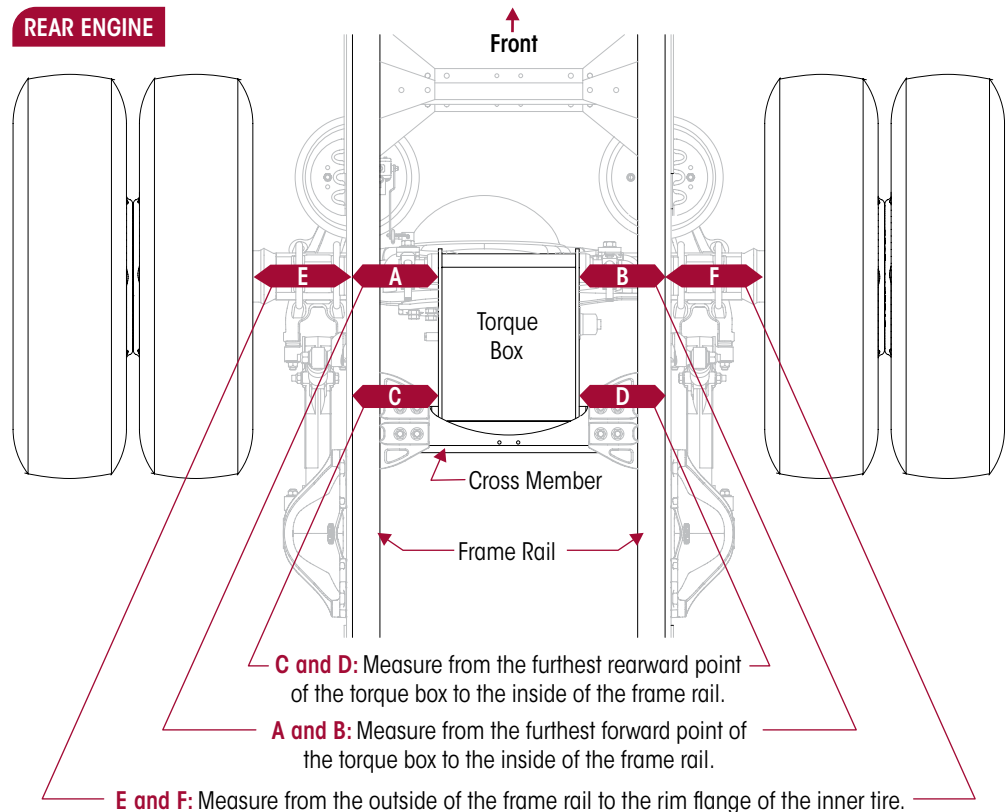

- B-1. Measure the distance between the left front side of the torque box and the left inside frame rail (**A**). Record the measurement.
- B-2. Measure the distance between the right front side of the torque box and the right inside frame rail (**B**). Record the measurement.
- B-3. Measure the distance between the left rear side of the torque box and the left inside frame rail (**C**). Record the measurement.



- B-4. Measure the distance between the right rear side of the torque box and the right inside frame rail (**D**). Record the measurement.
- B-5. Calculate the difference between location **A-B** as shown in Figure 7-6.
- B-6. Calculate the difference between location **C-D** as shown in Figure 7-6.
- B-7. Calculate the difference between location **A-C** as shown in Figure 7-6.
 - a. If all the calculated differences in Steps B-5 to B-7 are equal to or less than $\frac{1}{4}$ ", then proceed to Step D "Measuring the Lateral Alignment of the Axle."
 - b. If any of the calculated differences in Steps B-5 to B-7 are greater than $\frac{1}{4}$ ", this indicates the box is either offset or rotated. It will be necessary to correct the lateral alignment of the torque box. Proceed to Step C "Correcting Lateral Alignment of the Torque Box."

STEP C. CORRECTING TORQUE BOX LATERAL ALIGNMENT (IF NECESSARY)

NOTE

This step is only necessary if the torque box lateral alignment needs to be corrected as determined in Step B.

- C-1. Support the frame at ride height.



WARNING

PRIOR TO AND DURING DEFLATION AND INFLATION OF THE AIR SUSPENSION SYSTEM, ENSURE THAT ALL PERSONNEL AND EQUIPMENT ARE CLEAR FROM UNDER THE VEHICLE AND AROUND THE SERVICE AREA, FAILURE TO DO SO CAN CAUSE SERIOUS PERSONAL INJURY, DEATH, OR PROPERTY DAMAGE.

- C-2. See additional Air Spring Warnings and Instructions in the Important Safety Notice Section of this publication prior to deflating or inflating the suspension system.
- C-3. Disconnect the height control linkage assembly from the height control valve arm. Lower the height control valve arm to exhaust the air in the air springs and deflate the rear suspension, see vehicle manufacturer's instructions.
- C-4. Loosen the torque box clamp bolts at all four corners of the torque box.
- C-5. Using a pry bar, center the torque box in the frame rails. Measurements (**A** and **B**), (**C** and **D**) and (**A** and **C**) should be within $\frac{1}{4}$ " of each other. This will center the torque box and ensure parallelism of the torque box to the frame rails.



WARNING

IT IS IMPORTANT THAT THE TORQUE BOX CLAMP CONNECTIONS BE TIGHTENED IN THE PROPER SEQUENCE AND HAVE THE PROPER TIGHTENING TORQUE VALUES MAINTAINED. FAILURE TO DO SO CAN RESULT IN THE DEFORMATION OF PARTS, RESULTING IN THE LOSS OF CLAMP FORCE, BOLT FAILURE, LOSS OF THE AXLE'S ALIGNMENT, LOSS OF VEHICLE CONTROL, PROPERTY DAMAGE, OR PERSONAL INJURY.



CAUTION

THE TORQUE BOX CLAMP BOLTS MUST BE TIGHTENED WHEN THE VEHICLE IS AT RIDE HEIGHT. TIGHTENING THE CLAMP BOLTS WHEN THE VEHICLE IS NOT AT RIDE HEIGHT WILL PRODUCE A TWIST IN THE TORQUE BOX BUSHINGS RESULTING IN PREMATURE COMPONENT WEAR OF THE TORQUE BOX BUSHINGS, IMPROPER RIDE HEIGHT OF THE VEHICLE AND ALTER RIDE QUALITY.

- C-6. First snug, and then tighten the torque box to cross member clamp bolts in the proper sequence (inboard fasteners first then outboard fasteners), to prevent cross member deformation, see Figure 7-7. Tighten the cross member locknuts to  150-205 foot pounds torque.

FIGURE 7-7

REAR ENGINE

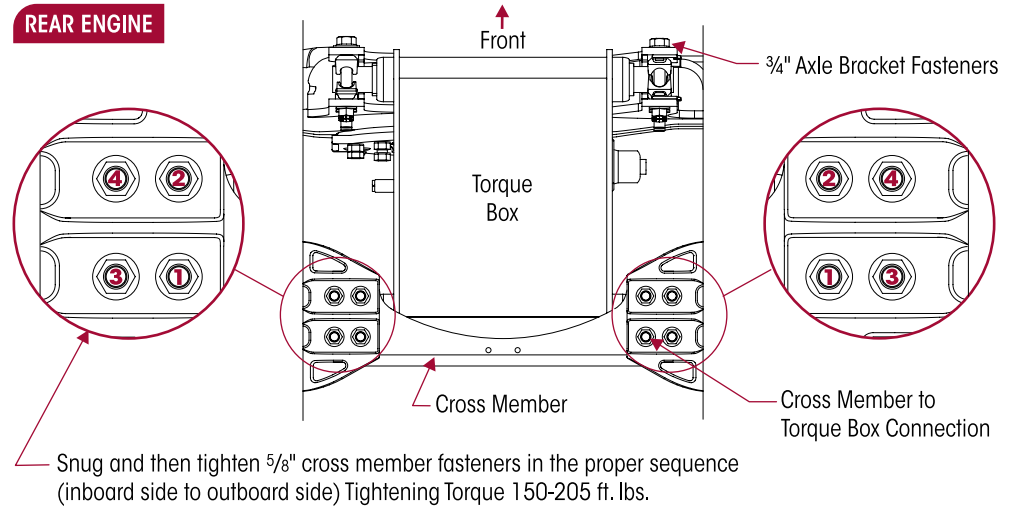

- C-7. Hand-tighten the torque box to axle bracket clamp bolts. **DO NOT** apply final tightening torque to the locknuts at this time as further adjustments may be required.
- C-8. Verify measurements, (A and B), (C and D) and (A and C) should be within $\frac{1}{4}$ " of each other.

STEP D. MEASURING THE LATERAL ALIGNMENT OF THE AXLE (See Figure 7-6)

- D-1. Measure the distance from the outside of the left frame rail to the rim flange of the left inner tire (E). Record the measurement.
- D-2. Measure the distance from the outside of the right frame rail to the rim flange of the right inner tire (F). Record the measurement.
- D-3. Calculate the difference between the two measurements (E-F).
 - (E-F $\leq \frac{1}{4}$ ") – If the difference is $\frac{1}{4}$ " or less then proceed to Step F "Measuring Axle Thrust Angle."
 - (E-F $> \frac{1}{4}$ ") – If the difference is greater than $\frac{1}{4}$ ", it will be necessary to correct the lateral alignment of the axle. Proceed to Step E "Correcting Lateral Alignment of the Axle".

STEP E. CORRECTING LATERAL ALIGNMENT OF THE AXLE (IF NECESSARY)

NOTE This step is only necessary if the lateral alignment of the axle needs to be corrected as determined in Step D.

NOTE It is important to ensure the torque box is centered and parallel to the frame rails before correcting lateral alignment on an axle. Refer to Step B.

- E-1. Support the frame at ride height.

WARNING

PRIOR TO AND DURING DEFLATION AND INFLATION OF THE AIR SUSPENSION SYSTEM, ENSURE THAT ALL PERSONNEL AND EQUIPMENT ARE CLEAR FROM UNDER THE VEHICLE AND AROUND THE SERVICE AREA, FAILURE TO DO SO CAN CAUSE SERIOUS PERSONAL INJURY, DEATH, OR PROPERTY DAMAGE.

- E-2. See additional Air Spring Warnings and Instructions in the Important Safety Notice Section of this publication prior to deflating or inflating the suspension system.
- E-3. Disconnect the height control linkage assembly from the height control valve arm. Lower the height control valve arm to exhaust the air in the air springs and deflate the rear suspension. (See vehicle manufacturer's instructions).

- E-4. Using the measurements from Step D "Measuring the Lateral Alignment of the Axle" determines which direction the axle needs to be moved to center the axle under the vehicle.
- E-5. Loosen the torque box to axle bracket clamp bolts. The bolts may already be loose from Step C-7. **DO NOT** loosen the torque box to cross member bolts.
- E-6. Move the axle in the direction required to center the axle under the vehicle. Measurements (E) and (F) should be within ¼" of each other.
- E-7. Hand-tighten the torque box to axle bracket clamp fasteners. **DO NOT** final torque the bolts at this time.
- E-8. Verify measurement (E) and (F) are within ¼" of each other.

STEP F. MEASURING AXLE THRUST ANGLE

FIGURE 7-8

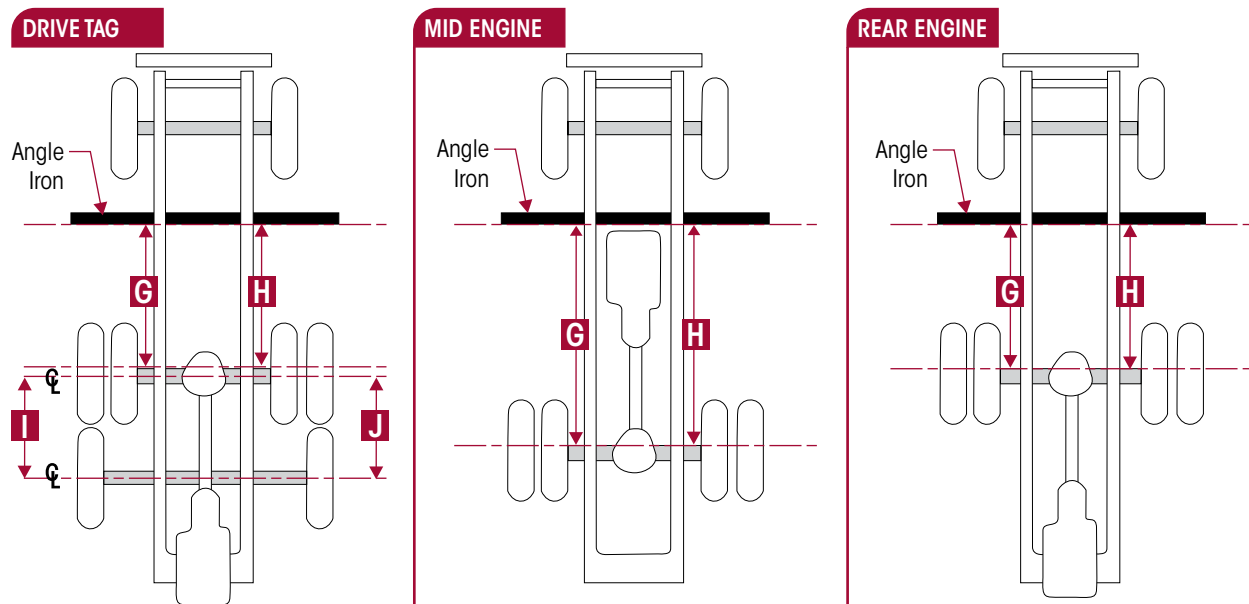

- F-1. If axle alignment equipment is not available, using "C" clamps, securely clamp a six-foot piece of straight bar stock or angle iron across the lower frame flange as shown in Figure 7-8. Select a location as far forward of the drive axle as possible where components will not interfere.

NOTE

A six-foot minimum length piece of straight bar stock must be used to ensure proper measurement to the axle. Axle alignment equipment must be used if components of body installation prevent the use of a six-foot piece of straight bar stock.

- F-2. Accurately square straight edge to frame using a carpenter's square.
- F-3. Using a measuring tape, measure from the straight edge to the forward face of the drive axle arm at the centerline of the axle top pad assembly on both sides of vehicle as shown in Figure 7-8, (G) and (H).
 - a. If measurements (G) and (H) are within the vehicle manufacturer's specifications then the thrust alignment of the drive axle is acceptable. If equipped with a auxiliary axle drive tag, proceed to H-1.
 - b. If measurements (G) and (H) are not within the vehicle manufacturer's specifications, it will be necessary to correct the drive axle's thrust angle. Proceed to Step G "Correcting Axle Thrust Angle."

STEP G. CORRECTING DRIVE AXLE THRUST ANGLE (IF NECESSARY)

NOTE

The HTB 210 is a parallelogram suspension. When correcting the drive axle's thrust angle, the spacers on the torque box and shims on the longitudinal torque rod must be adjusted in order to maintain parallelism and the drive axle pinion angle.

G-1. Support the frame at ride height.



WARNING

PRIOR TO AND DURING DEFLATION AND INFLATION OF THE AIR SUSPENSION SYSTEM, ENSURE THAT ALL PERSONNEL AND EQUIPMENT ARE CLEAR FROM UNDER THE VEHICLE AND AROUND THE SERVICE AREA, FAILURE TO DO SO CAN CAUSE SERIOUS PERSONAL INJURY, DEATH, OR PROPERTY DAMAGE.

G-2. See additional Air Spring Warnings and Instructions in the Important Safety Notice Section of this publication prior to deflating or inflating the suspension system.

G-3. Disconnect the height control linkage assembly from the height control valve arm. Lower the height control valve arm to exhaust the air in the air springs and deflate the rear suspension. (See vehicle manufacturer's instructions).

G-4. Loosen the torque box to axle bracket clamp bolts. The bolts may already be loose from Step C-7. **DO NOT** loosen the torque box to cross member bolts.



WARNING

THE DRIVE AXLE HAS ONE (1) AXLE BRACKET WITH ADJUSTABLE BAR PIN CLAMPS AND FOUR (4) AXLE BRACKET SPACERS, AND ONE (1) AXLE BRACKET WITH NON-ADJUSTABLE BAR PIN CLAMPS. THE BAR PIN CLAMP PAIRS MAY BE CHANGED FROM SIDE TO SIDE BUT MUST NOT BE MIXED. ALL FOUR (4) SPACERS MUST BE USED WITH THE ADJUSTABLE BAR PIN CLAMPS, WHICH ARE THINNER THAN THE NON-ADJUSTABLE BAR PIN CLAMPS. FAILURE TO DO SO CAN RESULT IN THE DEFORMATION OF PARTS, LOSS OF CLAMP FORCE, BOLT FAILURE, LOSS OF THE AXLE'S ALIGNMENT, LOSS OF VEHICLE CONTROL, PROPERTY DAMAGE, OR PERSONAL INJURY.

G-5. Locate the axle bracket that contains the adjustable bar pin clamps and axle bracket spacers, see Figure 7-9.

FIGURE 7-9

MID ENGINE

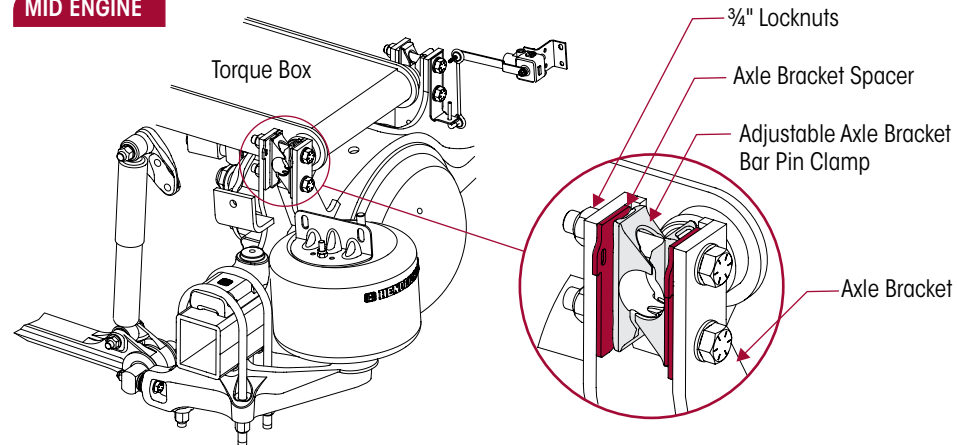

G-6. Remove all the axle bracket spacers from the axle bracket connection with the adjustable bar pin clamps. **DO NOT** remove adjustable axle bracket bar pin clamps, it is not necessary to remove the adjustable bar pin clamps or the axle bracket connection clamp bolts to perform adjustment.

FIGURE 7-10

REAR ENGINE

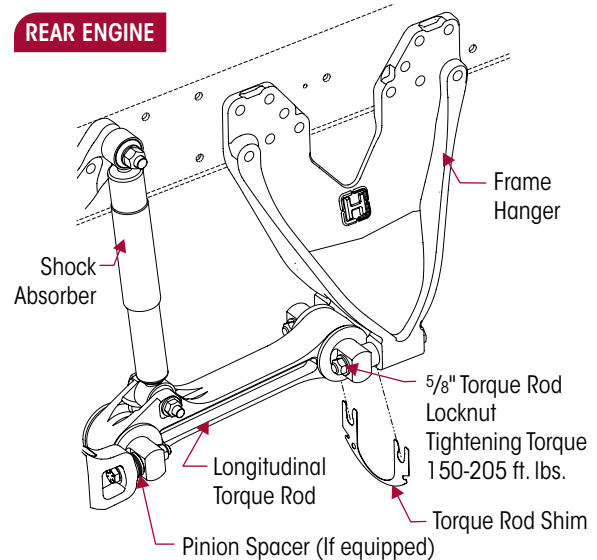

- G-7. Loosen the longitudinal torque rod fasteners and remove the torque rod shims from both ends of the longitudinal torque rod. **DO NOT** remove the pinion spacer (if equipped), see Figure 7-10.
- G-8. Adjust the axle in the direction necessary to correct the thrust angle.
- G-9. Fill any gap between the longitudinal torque rod and lower air spring bracket with longitudinal torque rod shims, see Figure 7-10. Longitudinal torque rod shims should only be placed on one side of the axle to adjust the thrust angle. Adding longitudinal torque rod shims to both sides of the axle will affect the axle pinion angle.
- G-10. Tighten the longitudinal torque rod locknuts to 150-205 foot pounds torque.
- G-11. Fill the gap between the axle bracket and the adjustable bar pin clamps with the axle bracket spacers removed in Step G-6. All four axle bracket spacers must be re-installed. **DO NOT** force the axle forward or backwards to install the axle bracket spacers. The axle bracket spacers may be arranged in any order to achieve an easy fit.

EXAMPLE

The axle bracket spacer arrangement may end up being three spacers in front and one behind the adjustable bar pin clamps, or no spacers in front and four behind the adjustable bar pin clamps, etc.

- G-12. Verify measurements (G) and (H) are within the vehicle manufacturer's specifications.

STEP H. FINAL TORQUE AXLE BRACKET CLAMP BOLTS



WARNING

IT IS IMPORTANT THAT THE TORQUE BOX CLAMP CONNECTIONS BE TIGHTENED IN THE PROPER SEQUENCE AND HAVE THE PROPER TIGHTENING TORQUE VALUES MAINTAINED. FAILURE TO DO SO CAN RESULT IN THE DEFORMATION OF PARTS, RESULTING IN THE LOSS OF CLAMP FORCE, BOLT FAILURE, LOSS OF THE AXLE'S ALIGNMENT, LOSS OF VEHICLE CONTROL, PROPERTY DAMAGE, OR PERSONAL INJURY.

- H-1. Tighten the axle bracket clamp locknuts in the proper sequence. Tighten the lower clamp locknut first, then the upper clamp locknut, see Figure 7-11. Tighten the locknuts to 290-310 foot pounds torque.



WARNING

PRIOR TO AND DURING DEFLATION AND INFLATION OF THE AIR SUSPENSION SYSTEM, ENSURE THAT ALL PERSONNEL AND EQUIPMENT ARE CLEAR FROM UNDER THE VEHICLE AND AROUND THE SERVICE AREA, FAILURE TO DO SO CAN CAUSE SERIOUS PERSONAL INJURY, DEATH, OR PROPERTY DAMAGE.

- H-2. See additional Air Spring Warnings and Instructions in the Important Safety Notice Section of this publication prior to deflating or inflating the suspension system.
- H-3. Connect the height control arm to the height control valve linkage assembly to inflate the suspension.
- H-4. Remove the frame supports. Check the ride height, refer Ride Height Adjustment in this section.

FIGURE 7-11

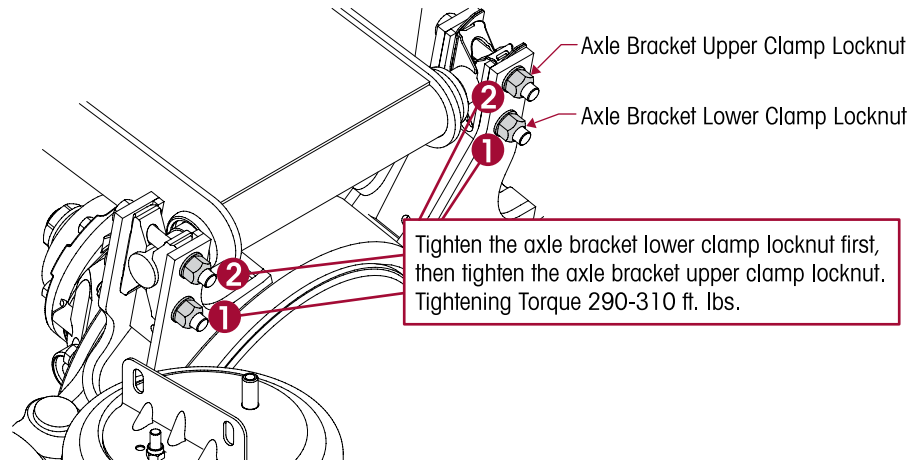

When alignment of the drive axle is within the manufacturer's specification and all final torques are completed, proceed to Step I - Measuring Auxiliary Axle Drive Tag Alignment.

STEP I. MEASURING AUXILIARY AXLE DRIVE TAG ALIGNMENT

FIGURE 7-12

The Quick-Align alignment feature incorporates two flanged washers that are inserted into slots located on each side of the frame bracket. The outboard flanged washer is eccentric, see Figure 7-12. Its outside diameter is position controlled by an adjustment guide. Rotating the eccentric washer clockwise or counter clockwise provides fore and aft movement of the suspension's axle, see Figure 7-13. The pivot connection is clamped together with a heavy hex cap screw, hardened washers and a Torq-Rite® nut. The Torq-Rite nut ensures proper torque and eliminates the need for a torque wrench.

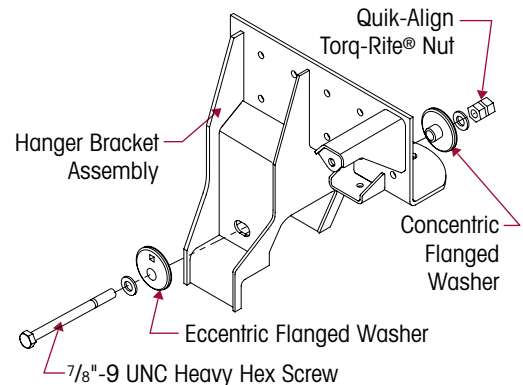
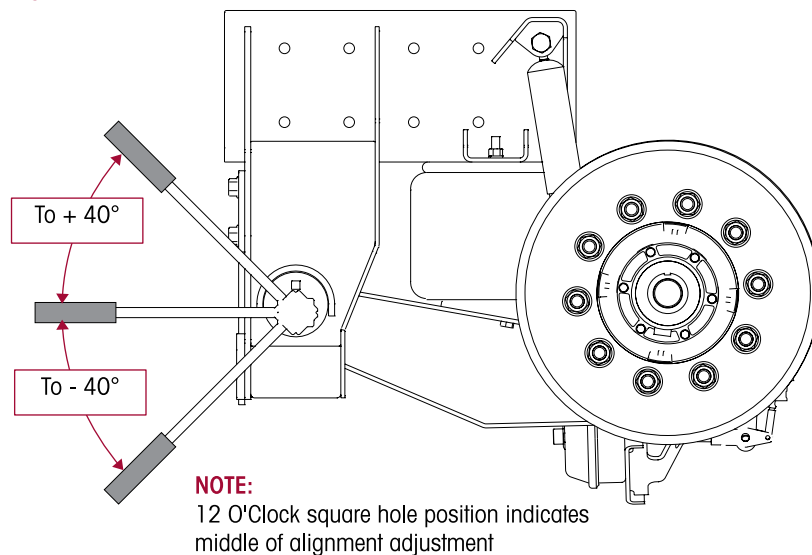

FIGURE 7-13



NOTE

Since the auxiliary axle drive tag will be aligned relative to the drive axle, it is essential that the drive axle is aligned within the manufacturer's specifications prior the auxiliary axle drive tag alignment.

- I-1. Using a Trammel Bar, measure the distance between the drive axle spindle center to the auxiliary axle drive tag spindle center on the left side of the vehicle (A).
- I-2. Using a Trammel Bar, measure the distance between the drive axle spindle center to the auxiliary axle drive tag spindle center on the right side of the vehicle (B).
- I-3. Calculate the difference between the two measurements (A-B).
 - a. If the difference is $\frac{1}{16}$ " or less, the auxiliary axle drive tag alignment is acceptable. Proceed to Step J-9.
 - b. If the difference is greater than $\frac{1}{16}$ ", it will be necessary to align the auxiliary axle drive tag. Proceed to Step J – Correcting Auxiliary Axle Drive Tag Alignment.

FIGURE 7-14

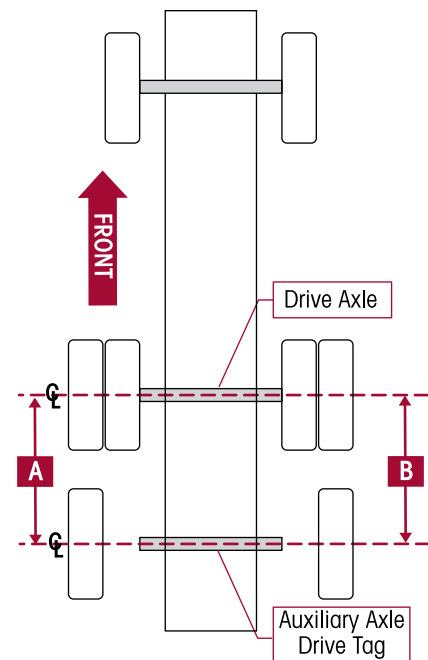

NOTE

The alignment of the auxiliary axle drive tag should be adjusted such that the auxiliary axle drive tag centerline is parallel to the centerline of the front axle and drive axle, see Figure 7-14.

STEP J. CORRECTING AUXILIARY AXLE DRIVE TAG ALIGNMENT (IF NECESSARY)

- J-1. Determine which side of the auxiliary axle drive tag needs to be adjusted to correct alignment.
- J-2. Remove the fasteners from the QUIK-ALIGN connection leaving the concentric washer (inboard) and eccentric washer (outboard) in place, see Figure 7-15.

NOTE

Hendrickson Auxiliary Axle recommends using a new QUIK-ALIGN pivot fastener kit for any axle alignment or when ever the pivot connection is disassembled.

- J-3. Install new fasteners in the QUIK-ALIGN connection. Tighten the fasteners tight enough to keep the eccentric washer against the adjustment guide, but loose enough to permit the hardened washers to rotate freely, see Figure 7-16.
- J-4. Ensure the $\frac{1}{2}$ " square hole on the eccentric washer is at the 12:00 O'clock position, see Figure 7-17.

FIGURE 7-15



FIGURE 7-16



FIGURE 7-17



- J-5. Using a ½" square drive breaker bar, rotate the eccentric washer to adjust the axle alignment until the axle is aligned, see Figure 7-18.

NOTE

Be sure axle alignment occurred without compressing the pivot bushing.

- J-6. Repeat Steps J-2 through J-4 on the opposite pivot connection if necessary to accurately complete the alignment of the auxiliary axle drive tag.
- J-7. Snug the pivot connection fasteners and recheck alignment, see Figure 7-19.
- J-8. Using a shallow socket, apply torque only to the outer hex of the Torq-Rite nut until it shears off, see Figure 7-20.

CAUTION

EXCEEDING TORQUE SPECIFICATIONS MAY RESULT IN FASTENER FAILURE.

- Recommended torque value for the Torq-Rite Nut is 500-600 foot pounds until the outer hex shears off.
- J-9. Engage the parking brake.
- J-10. Remove the wheel chocks.

FIGURE 7-18



FIGURE 7-19



FIGURE 7-20



PINION ANGLE

The vehicle manufacturer establishes drive axle pinion angle(s). Contact the vehicle manufacturer for the proper drive axle pinion angle(s) for your vehicle.

FIGURE 7-21

1. Use a work bay with a level surface.
2. Relax the suspension by slowly moving the vehicle back and forth several times in a straight line without using the brakes. This will slacken or loosen the suspension as the vehicle is positioned. End with all wheels positioned straight ahead. Try to roll to a stop without the brakes being applied. **DO NOT** set the parking brake. Consult the vehicle manufacturer for parking brake override procedure.
3. Chock the front wheels of the vehicle.
4. Verify and maintain the air system at full operating pressure.
5. Verify the vehicle is at the correct ride height. If the vehicle is not at the correct ride height it will be necessary to correct the ride height before proceeding.
6. Place the digital protractor on the frame rail, at the centerline of the axle, and zero the digital protractor.





7. Place the digital protractor on the axle housing as shown in Figure 7-21.
8. Record the pinion angle for each drive axle. Determine if the pinion angles are within the vehicle manufacturer's specified range.
9. If drive axle pinion angle is out of specification:
 - a. Verify the correct torque rod, lower air spring bracket, and pinion spacers (if equipped) are installed, refer to the Parts List Section of this publication.
 - b. If the correct components are installed and a correction to the drive axle pinion angle is required, it will be necessary to adjust the torque rod shims on both sides (left hand and right hand) of the axle in equal amounts. This will maintain axle alignment while correcting the pinion angle.
10. Determine which direction the axle needs to be tilted in order to achieve the correct pinion angle.
11. Add/remove shims at the longitudinal torque rod connections as required to achieve the proper pinion angle. Adjustments must be equal on both sides of the axle in order to maintain axle alignment.
12. When the pinion angle is correct tighten torque rod fasteners to  150-205 foot pounds torque and recheck the pinion angles.
13. Remove wheel chocks.

AUXILIARY AXLE WHEEL BEARING ADJUSTMENT

For technical assistance regarding wheel bearing adjustment, call Hendrickson Auxiliary Axle at 1-800-660-2829.

This procedure follows the guidelines of TMC RP 618.

1. Lubricate the bearing with clean axle lubricant of the same type used in the hub assembly.
2. After the wheel hub and bearings are assembled on the spindle, tighten the inner wheel bearing adjusting nut to  200 foot pounds torque while rotating the wheel hub assembly.
3. Back off the inner wheel bearing adjusting nut one full turn. Rotate the wheel.
4. Re-tighten the inner wheel bearing adjusting nut to  50 foot pounds torque while rotating the wheel hub assembly.
5. Back off the inner wheel bearing adjusting nut one third turn.
6. Install the locking washer. If dowel pin and washer are not aligned, remove the washer and turn it over and reinstall. If required, loosen the inner wheel bearing adjusting nut just enough for alignment.

CAUTION

NEVER TIGHTEN THE INNER WHEEL BEARING ADJUSTING NUT FOR ALIGNMENT AT THIS POINT OF THE PROCEDURE. THIS CAN PRELOAD THE BEARING AND CAUSE PREMATURE FAILURE.

7. Install and tighten the outer (jam) nut to  300-400 foot pounds torque.
8. Verify end play with a dial indicator, see Figure 7-22. Wheel end play is the free movement of the wheel assembly along the spindle axis.
 - a. Attach a dial indicator with its magnetic base to the hub.

FIGURE 7-22



With indicator mounted at bottom
push/pull at sides of drum



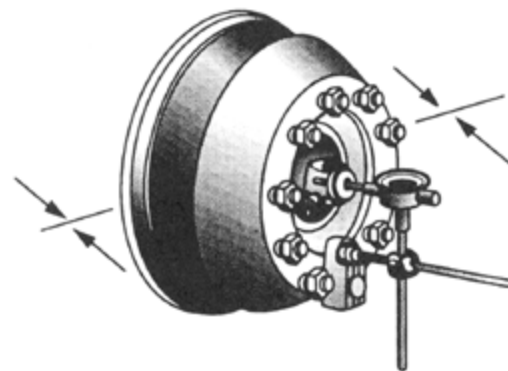

- b. Adjust the dial indicator so that its plunger or pointer is against the end of the spindle with its line of action parallel to the axis of the spindle.
- c. Grasp the hub assembly at the 3 o'clock and 9 o'clock positions. Push the hub in and pull out while oscillating it to seat the bearings. Care must be taken not to rotate the hub assembly. Read bearing end play as the total indicator movement.

NOTE

If end play is not within specification of 0.001" to 0.005", a readjustment is required.

9. Re-adjustment Procedure

- **Excessive End Play** — If the end play is too loose, remove the outer (jam) nut and pull the washer away from the inner wheel bearing adjusting nut, but not off the spindle. Tighten the inner wheel bearing adjusting nut to the next alignment hole of the washer. Reassemble the washer and re-tighten the outer (jam) nut to  300-400 foot pounds torque. Verify end play with a dial indicator.
- **Insufficient End Play** — If end play is not present, remove the outer (jam) nut and pull the washer away from the inner wheel bearing adjusting nut, but not off the spindle. Loosen the inner wheel bearing adjusting nut to the next alignment hole of the washer. Re-assemble the washer and re-tighten the outer (jam) nut to  300-400 foot pounds torque. Verify end play with a dial indicator.
- **Fine Tuning Adjustment** — If after performing the readjustment procedures, end play is 0.001"-0.005" range, if less play is desired, repeat the appropriate procedures, removing the washer from the spindle, tighten or loosen the inner wheel bearing adjusting nut the equivalent of ½ of an alignment hole, or reversing the alignment washer, and re-installing it onto the spindle. Reassemble and re-tighten the outer (jam) nut to  300-400 foot pounds torque. Verify end play with a dial indicator.

Secure outer nut by bending one washer tang over the outer nut.

**CAUTION**

BEFORE OPERATING THE VEHICLE, THE WHEEL HUB CAVITIES AND BEARINGS MUST BE LUBRICATED TO HELP PREVENT FAILURE.

SECTION 8

Component Replacement

FASTENERS

Hendrickson recommends when servicing the vehicle, replace all removed fasteners with new equivalent fasteners. Maintain correct torque values at all times. Check torque values as specified. See Hendrickson's Tightening Torque Specifications Section of this publication. If non-Hendrickson fasteners are used, follow torque specifications listed in the vehicle manufacturer's service manual.

AIR SPRING

DISASSEMBLY

1. Chock the wheels.
2. Support the frame at ride height.



WARNING

PRIOR TO AND DURING DEFLATION AND INFLATION OF THE AIR SUSPENSION SYSTEM, ENSURE THAT ALL PERSONNEL AND EQUIPMENT ARE CLEAR FROM UNDER THE VEHICLE AND AROUND THE SERVICE AREA, FAILURE TO DO SO CAN CAUSE SERIOUS PERSONAL INJURY, DEATH, OR PROPERTY DAMAGE.

3. See additional Air Spring Warnings and Instructions in the Important Safety Notice Section of this publication prior to deflating or inflating the suspension system.
4. Disconnect the height control linkage assembly from the height control valve arm. Lower the height control valve arm to exhaust the air in the air springs and deflate the rear suspension. (See vehicle manufacturer's instructions).
5. Remove the air line from the air spring.
6. Lubricate the lower air spring mounting stud with penetrating oil. This will help prevent the air spring mounting stud from breaking during the removal process.
7. Using **HAND TOOLS ONLY**, remove the lower locknut and washer from the lower air spring stud.
8. Remove the fasteners from the upper air spring mounting bracket to the frame rail.
9. Remove the air spring.

FIGURE 8-1

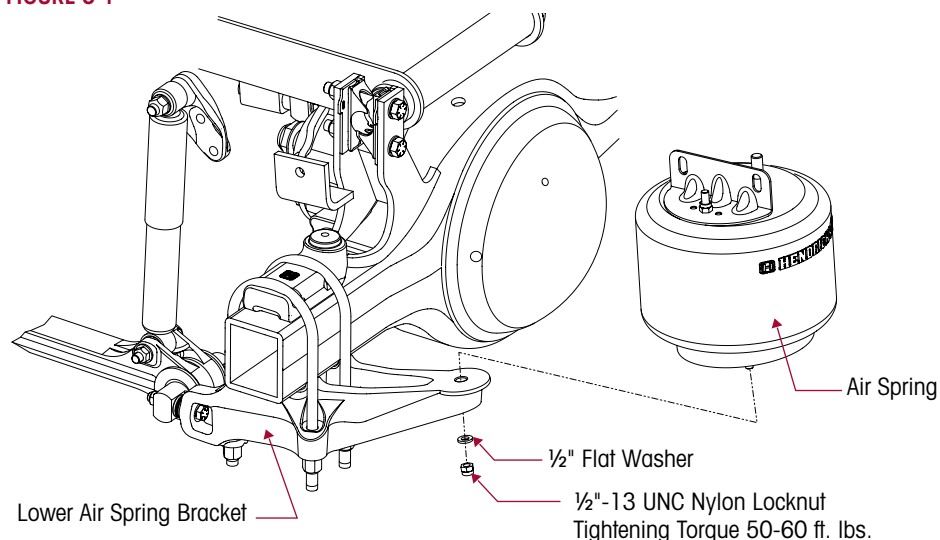

INSPECTION

1. Inspect all mounting surfaces and mounting brackets for any damage, replace as necessary.
2. Inspect air spring flex member for signs of damage or chaffing. Replace as necessary.

ASSEMBLY

1. Install the air spring between the frame and the lower air spring bracket, see Figure 8-2.

WARNING

FAILURE TO PRESS THE AIR SPRING AGAINST THE UNDERSIDE OF THE FRAME RAIL WHILE TIGHTENING THE UPPER AIR SPRING BRACKET CAN CAUSE COMPONENT DAMAGE AND PERSONAL INJURY OR PROPERTY DAMAGE.

FIGURE 8-2

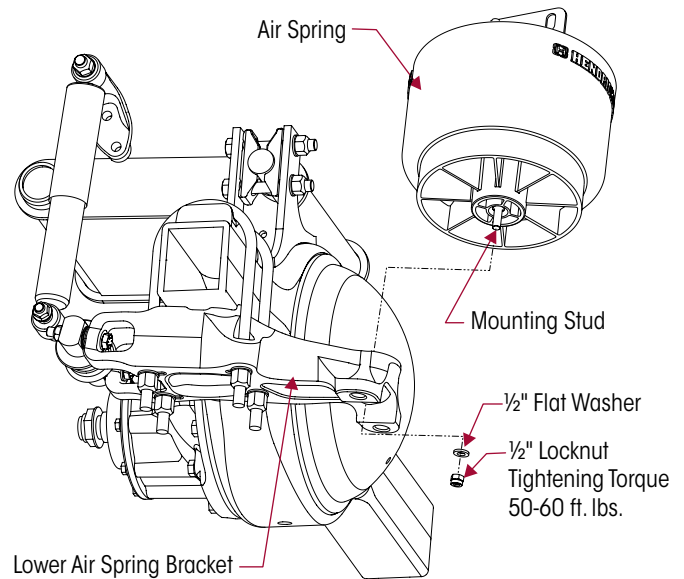

2. While holding the top of the air spring against the bottom of the frame rail, tighten the upper mounting fasteners to the frame rail. Tighten the fasteners to vehicle manufacturer's torque specifications.
3. Insert the lower mounting stud through the mounting hole in the lower air spring bracket.
4. Using **HAND TOOLS**, tighten the lower air spring mounting fastener to 50-60 foot pounds torque.
5. Connect the air line to the air spring.
6. See additional Air Spring Warnings and Instructions in the Important Safety Notice Section of this publication prior to deflating or inflating the suspension system.
7. Inflate the suspension by raising the height control valve's height control arm.
8. Connect the height control linkage assembly to the height control valve's height control arm by sliding the rubber grommet onto the stud.
9. Remove the frame supports.
10. Verify the vehicle is at the correct ride height. Correct as necessary. Refer to Ride Height Adjustment in the Alignment & Adjustments Section of this publication.
11. Remove the wheel chocks.

HEIGHT CONTROL VALVE

DISASSEMBLY

1. Chock the wheels of the vehicle.

WARNING

PRIOR TO AND DURING DEFLATION AND INFLATION OF THE AIR SUSPENSION SYSTEM, ENSURE THAT ALL PERSONNEL AND EQUIPMENT ARE CLEAR FROM UNDER THE VEHICLE AND AROUND THE SERVICE AREA, FAILURE TO DO SO CAN CAUSE SERIOUS PERSONAL INJURY, DEATH, OR PROPERTY DAMAGE.

2. See additional Air Spring Warnings and Instructions in the Important Safety Notice Section of this publication prior to deflating or inflating the suspension system.
3. Disconnect the height control linkage assembly from the height control valve arm by sliding the rubber grommet off the height control valve arm's stud. Lower the leveling valve arm to exhaust the air in the air springs and deflate the rear suspension.
4. Remove the air lines from the height control valve.
5. Remove the ¼" locknuts and washers that attach the height control valve to the frame mounting bracket.
6. Remove the height control valve, see Figure 8-3.
7. Remove the air line fittings from the height control valve.

ASSEMBLY

1. Install the air line fittings into the height control valve using Teflon thread seal.
2. Install the height control valve to the frame mounting bracket by attaching the ¼" washers and locknuts. Tighten to  7-10 foot pounds torque.
3. Connect the air lines to the height control valve. Reference the Plumbing Diagrams Section of this publication.
4. See additional Air Spring Warnings and Instructions in the Important Safety Notice Section of this publication prior to deflating or inflating the suspension system.
5. Inflate the suspension by raising the height control valve's height control arm.
6. Connect the height control linkage assembly to the height control valve's height control arm by sliding the rubber grommet onto the stud.
7. Verify proper ride height adjustment, see Ride Height Adjustment in the Preventive Maintenance Section of this publication.

FIGURE 8-3



SHOCK ABSORBER

DISASSEMBLY

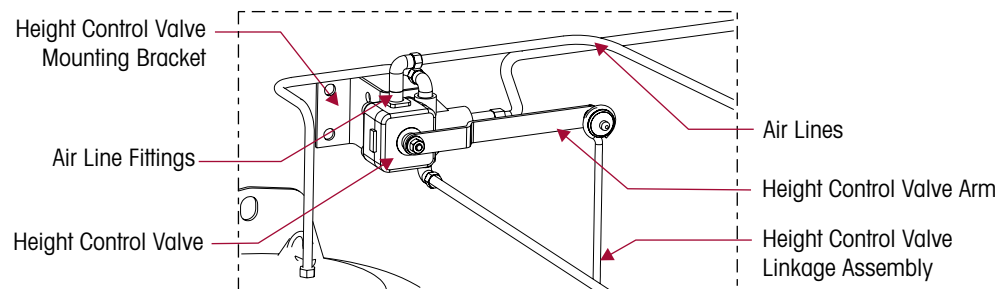
1. Chock the wheels of the vehicle.
2. Remove the fasteners from the lower shock absorber mount, see Figure 8-4.
3. Remove the locknut from the upper shock absorber through bolt.
4. Slide the shock absorber out of the lower mount.
5. Remove the shock absorber from the upper mounting through bolt.

INSPECTION

Inspect the shock absorber mounting brackets and hardware for damage or wear, and replace as necessary, see Preventive Maintenance Section of this publication.

FIGURE 8-4 DRIVE TAG SHOWN

ASSEMBLY

1. Install the shock absorber onto the upper mounting through bolt.
2. Install the locknut on the upper shock absorber mounting through bolt. **DO NOT** tighten at this time.
3. Install the lower shock absorber into the lower shock absorber mount on the longitudinal torque rod, see Figure 8-4.
4. Install the fastener through the lower shock mount. Install the locknut on the through bolt, see Figure 8-4. Tighten the lower shock absorber locknut to 150-205 foot pounds torque.
5. Tighten the upper shock absorber locknut to 260-300 foot pounds torque, see Figure 8-4.
6. Remove the wheel chocks.

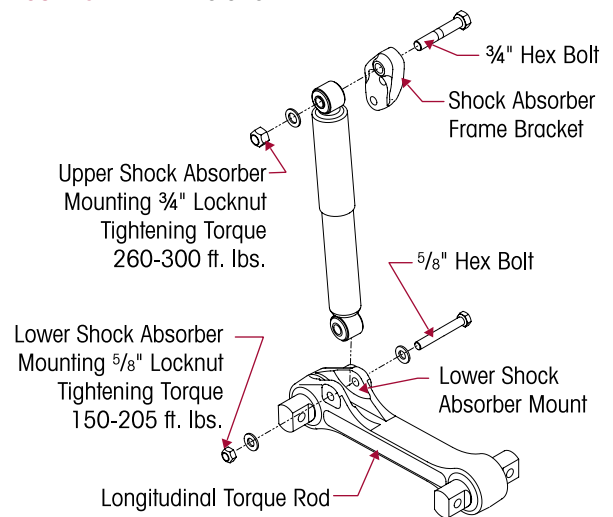

LONGITUDINAL TORQUE ROD

DANGER

THE AIR SPRING TRANSFERS LOAD TO THE FRAME HANGER THROUGH THE LONGITUDINAL TORQUE ROD. PRIOR TO LONGITUDINAL TORQUE ROD REMOVAL THE SUSPENSION AIR SYSTEM MUST BE DEFLATED. FAILURE TO DO SO WILL CAUSE THE AIR SPRING TO VIOLENTLY SHIFT, RESULTING IN POSSIBLE DAMAGE TO COMPONENTS AND/OR PERSONAL INJURY.

WARNING

THIS PROCEDURE FOR SERVICING A LONGITUDINAL TORQUE ROD IS PERFORMED WITH THE TORQUE ROD ON THE OPPOSITE SIDE OF THE VEHICLE PROPERLY CONNECTED TO THE FRAME HANGER AND LOWER AIR SPRING BRACKET. FAILURE TO DO SO CAN CAUSE THE AXLE TO ROTATE AND/OR SHIFT, RESULTING IN POSSIBLE DAMAGE TO COMPONENTS AND/OR PERSONAL INJURY. IF THE TORQUE RODS ON BOTH SIDES OF THE VEHICLE ARE TO BE REMOVED IT WILL BE NECESSARY TO SUPPORT THE AXLE PINION TO KEEP THE AXLE FROM SHIFTING.

CAUTION

FAILURE TO INSTALL THE TORQUE ROD SHIMS AND PINION SPACERS (IF EQUIPPED) IN THE SAME ORIENTATION AND LOCATION WILL REQUIRE A VEHICLE ALIGNMENT. IMPROPER VEHICLE ALIGNMENT CAN INCREASE TIRE WEAR.

**DISASSEMBLY**

1. Chock the wheels.
2. Support the frame at ride height.

**WARNING**

PRIOR TO AND DURING DEFLATION AND INFLATION OF THE AIR SUSPENSION SYSTEM, ENSURE THAT ALL PERSONNEL AND EQUIPMENT ARE CLEAR FROM UNDER THE VEHICLE AND AROUND THE SERVICE AREA, FAILURE TO DO SO CAN CAUSE SERIOUS PERSONAL INJURY, DEATH, OR PROPERTY DAMAGE.

3. See additional Air Spring Warnings and Instructions in the Important Safety Notice Section of this publication prior to deflating or inflating the suspension system.
4. Disconnect the height control valve linkage assembly from the height control valve arm. Lower the height control valve arm to exhaust the air in the air springs and deflate the rear suspension. (See vehicle manufacturer's instructions).
5. Remove the fastener from the lower shock absorber mount, see Figure 8-5.
6. Slide the shock absorber out of the lower shock absorber mount.

NOTE

Prior to disassembly of the longitudinal torque rod fasteners, note the orientation and quantity of torque rod shims and pinion spacers (if equipped), see Figure 8-5. It is required that the longitudinal torque rod shims be installed in the same orientation and location as removed to preserve the existing alignment and pinion angles.

**WARNING**

FAILURE TO INSTALL THE TORQUE ROD SHIMS IN THE SAME ORIENTATION AND LOCATION WILL REQUIRE A VEHICLE ALIGNMENT. IMPROPER VEHICLE ALIGNMENT CAN INCREASE TIRE WEAR.

7. Remove the pinion spacers (if equipped) and fasteners connecting the longitudinal torque rod to the lower air spring bracket.
8. Remove the fasteners, pinion spacers (if equipped) and torque rod shim(s) (if equipped) connecting the torque rods to the frame hanger.

SERVICE HINT

It may be necessary to pry the longitudinal torque rod down away from the frame hanger.

9. Remove the longitudinal torque rod.

INSPECTION

Inspect all mating components for damage or wear. Replace as necessary.

ASSEMBLY

1. Install the torque rod fasteners in the lower air spring bracket slots, see Figure 8-5.

NOTE

It is required that the longitudinal torque rod shims and pinion spacers (if equipped) be installed in the same orientation and location as removed to preserve the existing alignment and pinion angles.

2. Install any pinion spacers (if equipped) and torque rod shims between the longitudinal torque rod and lower air spring bracket.

NOTE

The longitudinal torque rod must be installed with the shock absorber mount facing upward adjacent to the lower air spring bracket, see Figure 8-5.

3. Install the longitudinal torque rod onto the lower air spring bracket.
4. Loosely install the lower air spring bracket locknuts. **DO NOT** tighten at this time.
5. Pivot the longitudinal torque rod in line with the mounting holes of the frame hanger.
6. Install the torque rod fasteners through the frame hanger; and install torque rod shims and pinion spacers (if equipped) that may have been removed from this connection.
7. Install the shock absorber into the lower shock absorber mount on the longitudinal torque rod.



FIGURE 8-5

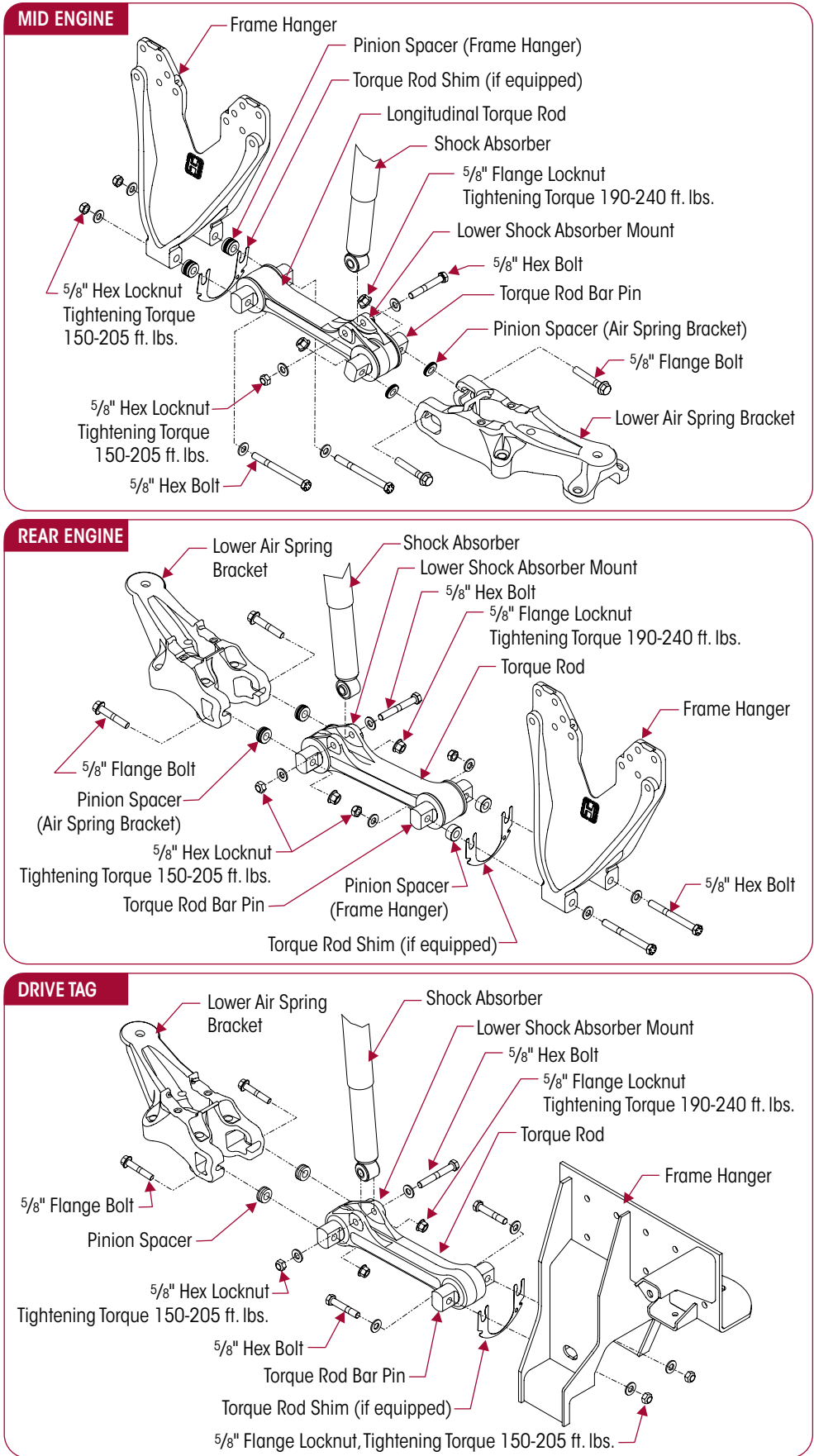



8. Install the lower shock absorber fasteners and tighten to 150-205 foot pounds torque.
9. Tighten torque rod to lower air spring bracket fasteners to 190-240 foot pounds torque.
10. Tighten torque rod to frame hanger fasteners to 150-205 foot pounds torque.
11. See additional Air Spring Warnings and Instructions in the Important Safety Notice Section of this publication prior to deflating or inflating the suspension system.
12. Inflate the suspension by raising the height control valve's height control arm.
13. Connect the height control linkage assembly to the height control valve's height control arm by sliding the rubber grommet onto the stud.
14. Remove the frame supports.
15. Verify the vehicle is at the correct ride height. Correct as necessary. Refer to Ride Height Adjustment in the Alignment & Adjustments Section of this publication.
16. Remove the wheel chocks.

LONGITUDINAL TORQUE ROD BUSHING

DISASSEMBLY

You will need:

- A vertical press with a capacity of at least 10 tons.
- Torque Rod Bushing Receiving Tool , see Special Tools Section
- Torque Rod Bushing Assembly Tool (Funnel) – Part No. 66086-000, see Special Tools Section

WARNING

DO NOT USE HEAT OR USE A CUTTING TORCH TO REMOVE THE BUSHINGS FROM THE LONGITUDINAL TORQUE ROD. THE USE OF HEAT WILL ADVERSELY AFFECT THE STRENGTH OF THE LONGITUDINAL TORQUE ROD. HEAT CAN CHANGE THE MATERIAL PROPERTIES. A COMPONENT DAMAGED IN THIS MANNER CAN RESULT IN THE LOSS OF VEHICLE CONTROL AND POSSIBLE PERSONAL INJURY OR PROPERTY DAMAGE.

1. Remove the longitudinal torque rod as detailed in this section.
2. Install the longitudinal torque rod in the press. Support the longitudinal torque rod end hub on the receiving tool with the end hub of the longitudinal torque rod centered on the tool. Be sure the longitudinal torque rod is squarely supported on the press bed.
3. Push directly on the bar pin until the bushing clears the longitudinal torque rod end hub.

INSPECTION AND CLEANING

1. Inspect the longitudinal torque rod for straightness, wear, or cracks. Replace as necessary.

NOTE

Care must be used when servicing the aluminum longitudinal torque rod and aluminum bar pin components to avoid damaging them.

2. Clean and inspect the inner diameter of the longitudinal torque rod end tubes. Break any sharp edges and remove any nicks with an emery cloth.

ASSEMBLY

NOTE

DO NOT use petroleum or soap base lubricant. Such lubricants can cause adverse reactions with the bushing, such as deterioration of the rubber, causing premature failure.

1. Lubricate the inner diameter of the torque rod end hub and the assembly funnel, and the new rubber bushing with P-80® Lubricant (refer to the Parts List Section of this publication) or light Naphthenic Base Oil, such as 60 SUS at 100°F, see Figure 8-6.

2. Support the torque rod end hub on the receiving tool with the end hub of the torque rod centered on the receiving tool.
3. Place the assembly funnel centered on the torque rod end hub, see Figure 8-7.
4. Place the torque rod bushing centered in the assembly funnel, see Figure 8-8. The bar pin must have the mounting flats positioned as indicated in Figure 8-9.

FIGURE 8-6



FIGURE 8-7



FIGURE 8-8



FIGURE 8-9

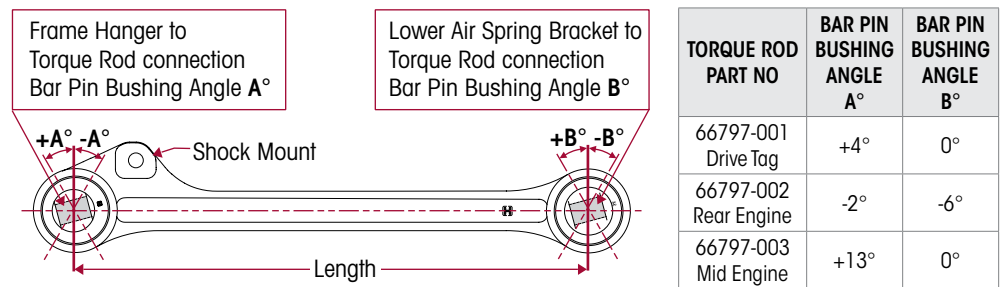

5. Press the bar pin through the assembly funnel into torque rod end hub until the rubber clears the assembly funnel. When pressing in the new bushings overshoot the desired final position by approximately $\frac{3}{16}$ " , see Figure 8-10.
6. Remove the assembly funnel.
7. Press the bar pin again from the opposite side to center the bar pin within the torque rod end hub, see Figure 8-11. The rubber bushing and the bar pin must be centered within the torque rod end hubs.

FIGURE 8-10



FIGURE 8-11





- Wipe off any excess lubricant. Allow the lubricant a minimum of four hours to dissipate before operating the vehicle.

CAUTION

IF THE TORQUE ROD ASSEMBLY IS NOT ALLOWED THE ALLOTTED TIME FOR THE LUBRICANT TO DISSIPATE, THE BUSHING WILL SLIDE FROM THE LONGITUDINAL TORQUE ROD END HUB. IF THIS OCCURS, THE BUSHING MAY BE DAMAGED AND THE BUSHING WILL THEN NEED TO BE REMOVED AND A NEW BUSHING RE-INSTALLED.

- Install longitudinal torque rod assembly as detailed in this section.

TORQUE BOX

It is important to inspect the torque box during preventive maintenance service. Visually inspect the torque box for cracks, damage, torn or shredded rubber, or any signs of looseness at the bar pin clamps. Replace all worn or damaged parts. The torque box is a non-serviceable item and must be replaced as an assembly, if damaged, or the bushings are worn out. Check all fasteners for proper torque, see Tightening Torque Specifications Section of this publication.

DISASSEMBLY

- Chock the wheels.
- Support the frame at ride height.

WARNING

THE TORQUE BOX ALONG WITH THE TORQUE RODS RESTRAIN THE AXLE, PREVENTING AXLE MOVEMENT. PRIOR TO TORQUE BOX AND/OR TORQUE ROD DISASSEMBLY VERIFY THAT THE AXLE BEING SERVICED IS SUPPORTED UNDER THE PINION HOUSING/DIFFERENTIAL, SO THAT THE AXLE DOES NOT MOVE OR ROTATE. FAILURE TO DO SO CAN ALLOW THE AXLE TO ROTATE AND/OR SHIFT, CAUSING COMPONENT DAMAGE, AND/OR SEVERE PERSONAL INJURY.

- Support the axle housing and pinion on the axle being serviced.

WARNING

PRIOR TO AND DURING DEFLATION AND INFLATION OF THE AIR SUSPENSION SYSTEM, ENSURE THAT ALL PERSONNEL AND EQUIPMENT ARE CLEAR FROM UNDER THE VEHICLE AND AROUND THE SERVICE AREA, FAILURE TO DO SO CAN CAUSE SERIOUS PERSONAL INJURY, DEATH, OR PROPERTY DAMAGE.

- See additional Air Spring Warnings and Instructions in the Important Safety Notice Section of this publication prior to deflating or inflating the suspension system.
- Disconnect the height control linkage assembly from the height control valve arm. Lower the height control valve arm to exhaust the air in the air springs and deflate the rear suspension. (See vehicle manufacturer's instructions).

NOTE

Prior to disassembly of the torque box clamp connections, note the orientation and quantity of axle bracket spacers and bar pin clamps, see Figure 8-12. It is required that the axle bracket spacers and bar pin clamps be installed in the same orientation and location as removed to preserve the existing alignment and pinion angles.

- Remove the torque box to axle bracket fasteners.

WARNING

THE DRIVE AXLE WILL HAVE ONE AXLE BRACKET WITH ADJUSTABLE BAR PIN CLAMPS AND FOUR (4) AXLE BRACKET SPACERS, AND ONE (1) AXLE BRACKET WITH NON-ADJUSTABLE BAR PIN CLAMPS. THE BAR PIN CLAMP PAIRS MAY BE CHANGED FROM SIDE TO SIDE BUT MAY NOT BE MIXED. ALL FOUR (4) SPACERS MUST BE USED WITH THE ADJUSTABLE BAR PIN CLAMPS, WHICH ARE THINNER THAN THE NON-ADJUSTABLE BAR PIN CLAMPS. FAILURE TO DO SO MAY RESULT IN THE DEFORMATION OF PARTS, LOSS OF CLAMP FORCE, BOLT FAILURE, LOSS OF THE AXLE'S ALIGNMENT, LOSS OF VEHICLE CONTROL, PROPERTY DAMAGE, OR PERSONAL INJURY.

- Loosen the eight (8) cross member bolts (four per side), connecting the torque box to the cross member. **DO NOT** remove at this time.
- Pivot the torque box up and out of the axle brackets. Retain the spacers and bar pin clamps from the axle brackets.

CAUTION

9. Remove the eight (8) previously loosened bolts from the cross member.

THE TORQUE BOX IS HEAVY (APPROXIMATELY 100 LBS.), THE USE OF A LIFTING DEVICE IS REQUIRED FOR REMOVAL AND INSTALLATION OF THE TORQUE BOX. DO NOT ATTEMPT REMOVAL OR INSTALLATION WITHOUT THE PROPER EQUIPMENT.

10. Slide the torque box out of the cross member. Retain the clamp blocks from the cross member.

FIGURE 8-12

MID ENGINE

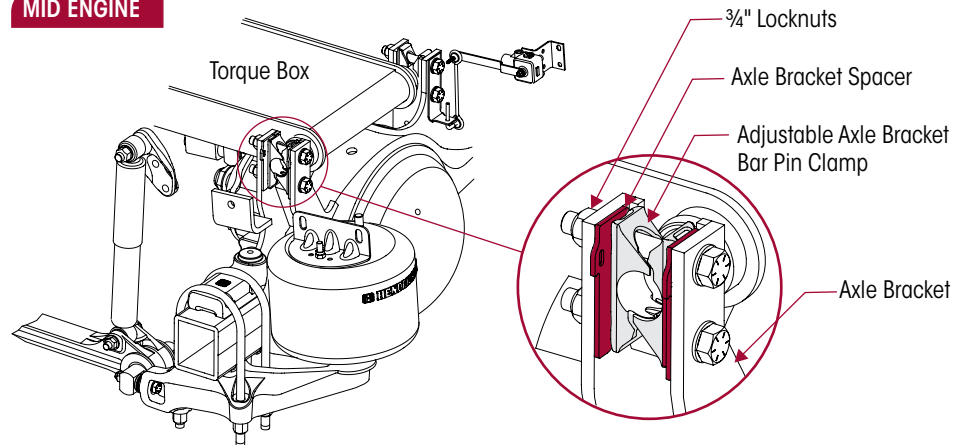

INSPECTION

1. Inspect all mating components including torque box, torque box bushings, and bar pin clamps for cracks, damage or wear. Replace as necessary.
2. Inspect cross member C-channel, cross member gussets, and bar pin clamps for cracks, signs of damage, or wear. Replace as necessary.
3. Inspect the axle brackets and axle welds for cracks, signs of damage, or wear. If the axle brackets show excessive wear, or the welds have cracks, the components will need to be repaired or replaced. If repair is needed, contact the vehicle or axle manufacturer for approved repair procedures.

ASSEMBLY

CAUTION

THE TORQUE BOX IS HEAVY (APPROXIMATELY 100 POUNDS), THE USE OF A LIFTING DEVICE IS REQUIRED FOR REMOVAL AND INSTALLATION OF THE TORQUE BOX. DO NOT ATTEMPT REMOVAL OR INSTALLATION WITHOUT THE PROPER EQUIPMENT.

1. Maneuver the torque box into position by first sliding the torque box bar pin into the cross-member, then into the axle brackets.
2. Slide the cross member bar pin clamps onto the torque box bar pin from the side. Loosely install the eight cross member bolts through the cross member and cross member bar pin clamps, see Figure 8-13. Install the washers and locknuts. **DO NOT** tighten at this time.

WARNING

THE DRIVE AXLE WILL HAVE ONE AXLE BRACKET WITH ADJUSTABLE BAR PIN CLAMPS AND FOUR (4) AXLE BRACKET SPACERS, AND ONE (1) AXLE BRACKET WITH NON-ADJUSTABLE BAR PIN CLAMPS. THE BAR PIN CLAMP PAIRS MAY BE CHANGED FROM SIDE TO SIDE BUT MAY NOT BE MIXED. ALL FOUR (4) SPACERS MUST BE USED WITH THE ADJUSTABLE BAR PIN CLAMPS, WHICH ARE THINNER THEN THE NON-ADJUSTABLE BAR PIN CLAMPS. FAILURE TO DO SO MAY RESULT IN THE DEFORMATION OF PARTS, LOSS OF CLAMP FORCE, BOLT FAILURE, LOSS OF THE AXLE'S ALIGNMENT, LOSS OF VEHICLE CONTROL, PROPERTY DAMAGE, OR PERSONAL INJURY.

3. Install the axle bracket bar pin clamps and all four (4) spacers that were removed during disassembly. Ensure all axle bracket spacers are installed in the same position as noted upon disassembly. Loosely install the axle bracket clamp bolts, see Figure 8-13.

FIGURE 8-13

MID ENGINE

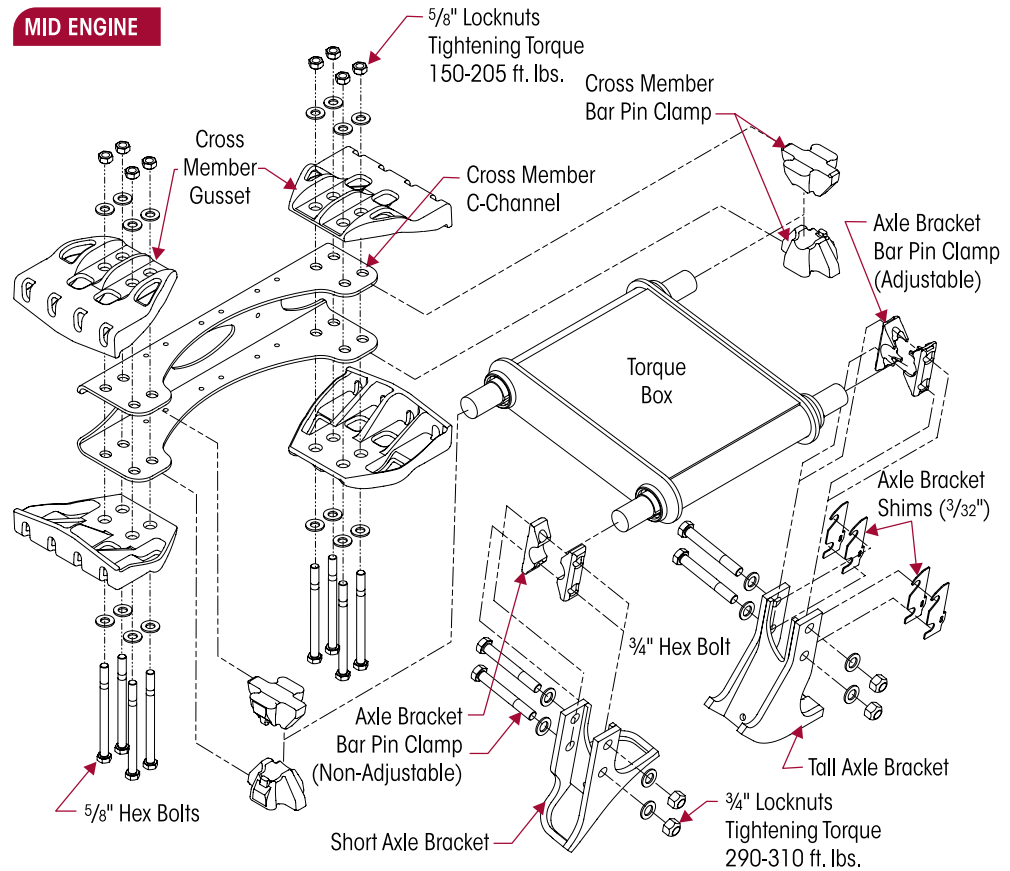

4. See additional Air Spring Warnings and Instructions in the Important Safety Notice Section of this publication prior to deflating or inflating the suspension system.
5. Connect the height control arm to the height control valve linkage assembly to inflate the suspension.
6. Remove the frame and the axle housing/differential supports.
7. Verify proper ride height adjustment, see Ride Height Adjustment in the Alignment & Adjustments Section of this publication. Correct as necessary.
8. Perform an axle alignment that includes the final torque box fastener tightening to torque specification. See Alignment in the Alignment & Adjustments Section of this publication that also contains final tightening torque values. Correct as necessary.

CLAMP GROUP – TOP PAD, LOWER AIR SPRING BRACKET, U-BOLTS

WARNING

IT IS IMPORTANT THAT THE U-BOLT CLAMP GROUP CONNECTION BE PROPERLY ALIGNED AND HAVE THE PROPER TIGHTENING TORQUE VALUES MAINTAINED. METAL SURFACES CAN WORK AND WEAR AGAINST OTHER RELATED CLAMP GROUP COMPONENTS IF NOT PROPERLY ALIGNED OR PROPERLY TIGHTENED TO MAINTAIN THE PROPER CLAMP FORCE. FAILURE TO DO SO CAN CAUSE PREMATURE COMPONENT WEAR, POSSIBLE SEPARATION OF THE CLAMP GROUP, CAUSING LOSS OF VEHICLE CONTROL, PROPERTY DAMAGE, OR PERSONAL INJURY.

WARNING

THIS PROCEDURE TO SERVICE THE CLAMP GROUP IS PERFORMED WITH THE CLAMP GROUP, FRAME HANGER, AND TORQUE RODS ON THE OPPOSITE SIDE OF THE VEHICLE PROPERLY CONNECTED. FAILURE TO DO SO COULD ALLOW THE AXLES TO SHIFT RESULTING IN POSSIBLE DAMAGE TO COMPONENTS AND/OR PERSONAL INJURY. IF COMPONENTS ON BOTH SIDES OF THE VEHICLE ARE TO BE REMOVED IT WILL BE NECESSARY TO SUPPORT THE AXLE AND AXLE PINION TO KEEP THE AXLE FROM SHIFTING.

DISASSEMBLY

1. Chock the wheels.
2. Support the frame at ride height.

WARNING

PRIOR TO AND DURING DEFLATION AND INFLATION OF THE AIR SUSPENSION SYSTEM, ENSURE THAT ALL PERSONNEL AND EQUIPMENT ARE CLEAR FROM UNDER THE VEHICLE AND AROUND THE SERVICE AREA, FAILURE TO DO SO CAN CAUSE SERIOUS PERSONAL INJURY, DEATH, OR PROPERTY DAMAGE.

3. See additional Air Spring Warnings and Instructions in the Important Safety Notice Section of this publication prior to deflating or inflating the suspension system.
4. Disconnect the height control linkage assembly from the height control valve arm. Lower the height control valve arm to exhaust the air in the air springs and deflate the rear suspension. (See vehicle manufacturer's instructions).
5. Remove the air line from the air spring.
6. Lubricate the lower air spring mounting stud with penetrating oil. This will help prevent the air spring mounting stud from breaking during the removal process.

FIGURE 8-14

7. Using **HAND TOOLS ONLY**, remove the lower locknut and washer from the lower air spring stud.
8. Remove the fasteners from the upper air spring mounting bracket to the frame rail. See Figure 8-14.
9. Remove the air spring.

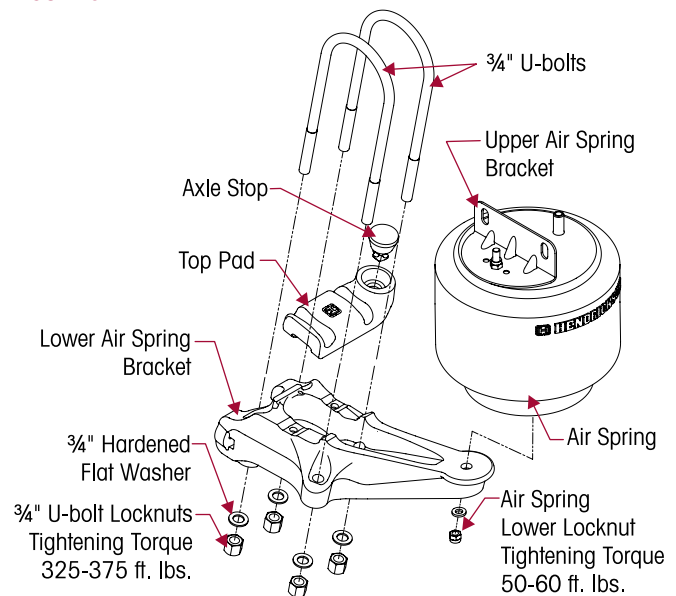
NOTE

Prior to disassembly of the longitudinal torque rod fasteners, note the orientation and quantity of torque rod shims and pinion spacers (if equipped). It is required that the longitudinal torque rod shims and pinion spacer be installed in the same orientation and location as removed to preserve the existing alignment and pinion angles.

WARNING

FAILURE TO INSTALL THE TORQUE ROD SHIMS IN THE SAME ORIENTATION AND LOCATION WILL REQUIRE A VEHICLE ALIGNMENT. IMPROPER VEHICLE ALIGNMENT CAN INCREASE TIRE WEAR.

10. Remove the locknuts connecting the longitudinal torque rod to the lower air spring bracket, see Figure 8-15.
11. Remove the four U-bolt locknuts and washers. Discard the fasteners.
12. Pry the longitudinal torque rod down and remove the lower air spring bracket.
13. Remove the U-bolts and top pad.

FIGURE 8-15

MID ENGINE

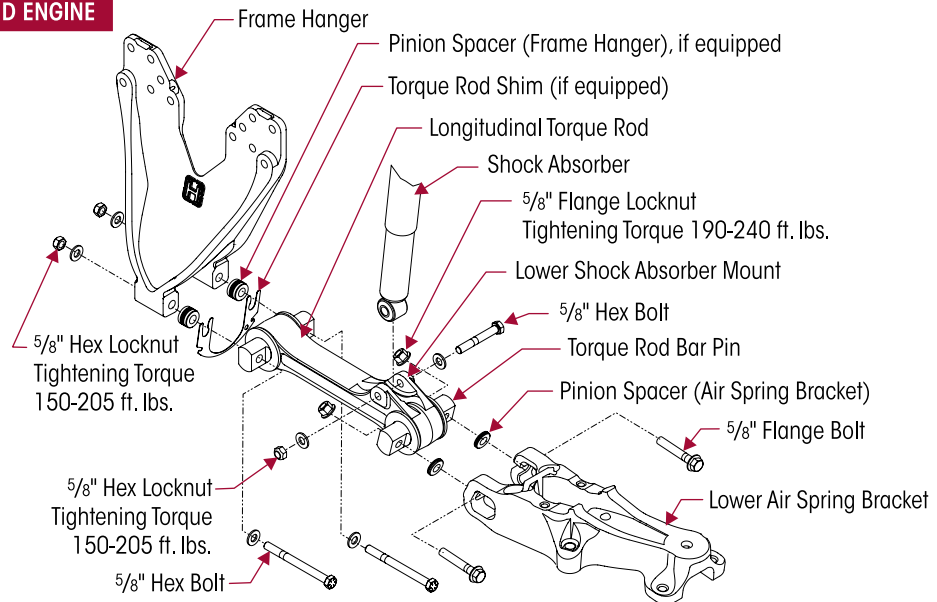

INSPECTION

Inspect the air spring bracket, top pad, rubber axle stop, and longitudinal torque rods for cracks, damage, or excessive wear. Replace as necessary. See Preventive Maintenance Section of this publication.

ASSEMBLY

1. Install the two longitudinal torque rod bolts in the slots of the air spring bracket, see Figure 8-16.

NOTE

It is required that the longitudinal torque rod shims and pinion spacers (if equipped) be installed in the same orientation and location as removed to preserve the existing alignment and pinion angles.

2. Install any pinion spacers (if equipped) and shims between the longitudinal torque rod and air spring bracket that were removed.
3. Install the lower air spring bracket onto the torque rod bar pin. Loosely install the locknuts on the longitudinal torque rod bolts. **DO NOT** tighten at this time.

NOTE

Verify the longitudinal torque rod is installed correctly. The lower shock mount on the longitudinal torque rod should be facing up, adjacent to the lower air spring bracket, see Figure 8-16.

4. Install the top pad on top of the axle housing. Verify the axle stop is on the inboard side. Ensure that the top pad has engaged the dowel pin on the axle housing.
5. Install new U-bolts over the top pad and through the lower air spring bracket. Verify U-bolts sit in the channels of the top pad.
6. Install hardened flat washers and locknuts on U-bolts.
7. Snug U-bolt locknuts evenly, see Figure 8-16. Verify the lower air spring bracket is seated properly against the axle housing.

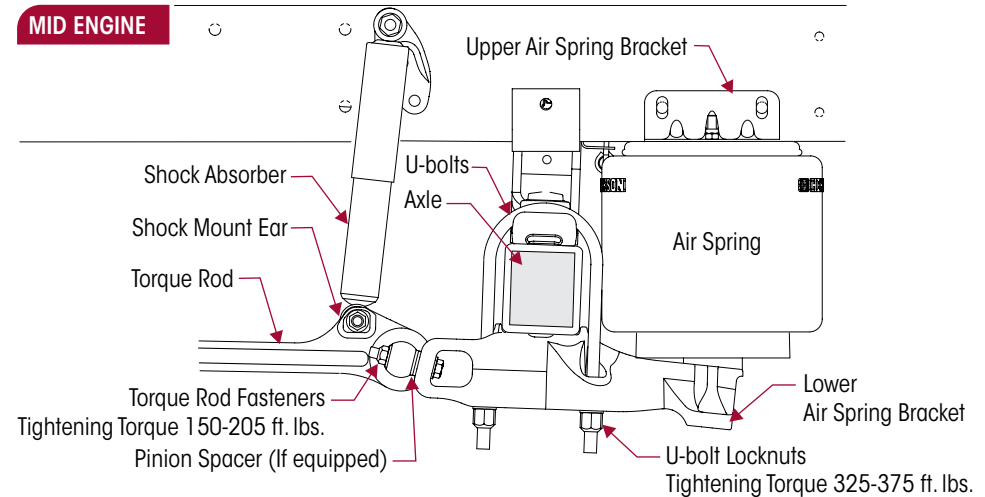
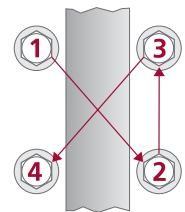
FIGURE 8-16

FIGURE 8-17

8. Tighten the U-bolt locknuts evenly in 50 foot pounds increments to 325-375 foot pounds torque in the proper pattern to achieve uniform bolt tension, see Figure 8-17.
9. Tighten the longitudinal torque rod fasteners to 150-205 foot pounds torque.

WARNING

FAILURE TO PRESS THE AIR SPRING AGAINST THE UNDERSIDE OF THE FRAME WHILE TIGHTENING THE UPPER AIR SPRING BRACKET CAN RESULT IN COMPONENT DAMAGE AND PERSONAL INJURY OR PROPERTY DAMAGE.

10. While holding the top of the air spring against the bottom of the frame rail, tighten the upper mounting fasteners to the frame rail. Tighten the fasteners to vehicle manufacturer's torque specifications.
11. Insert the lower mounting stud through the mounting hole in the lower air spring bracket.
12. Using **HAND TOOLS**, tighten the lower air spring mounting fastener to 50-60 foot pounds torque.
13. Connect the air line to the air spring.
14. See additional Air Spring Warnings and Instructions in the Important Safety Notice Section of this publication prior to deflating or inflating the suspension system.
15. Inflate the suspension by raising the height control valve's height control arm.
16. Connect the height control linkage assembly to the height control valve's height control arm by sliding the rubber grommet onto the stud.
17. Remove the frame supports.
18. Verify the vehicle is at the correct ride height. Correct as necessary. Refer to Ride Height Adjustment in the Alignment & Adjustment section of this publication.
19. Remove the wheel chocks.

AXLE STOP

The axle stops are rubber plugs installed in the top pad assembly. They may be renewed without disassembly of the suspension.

DISASSEMBLY

1. Chock the wheels.
2. Insert a small pry bar between the top pad and the axle stop. Pry axle stop up and out of the top pad.

ASSEMBLY

FIGURE 8-18

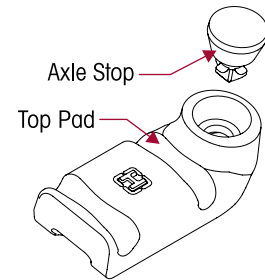

NOTE

DO NOT use petroleum or soap base lubricant. Such lubricants can cause adverse reactions with the bushing, such as deterioration of the rubber, causing premature failure.

1. Lubricate the new axle stop with light Naphthenic base oil, such as 60 SUS at 100°F or P-80® lubricant.
2. Place axle stop over the mounting hole in the top pad, see Figure 8-18.
3. Using a rubber mallet, lightly tap the axle stop to seat it in the top pad.
4. Remove the wheel chocks.

FRAME HANGER (MID-ENGINE AND REAR-ENGINE)

DANGER

THE AIR SPRING TRANSFERS LOAD TO THE FRAME HANGER THROUGH THE LONGITUDINAL TORQUE ROD. PRIOR TO LONGITUDINAL TORQUE ROD REMOVAL THE SUSPENSION AIR SYSTEM MUST BE DEFLATED. FAILURE TO DO SO WILL CAUSE THE AIR SPRING TO VIOLENTLY SHIFT, RESULTING IN POSSIBLE DAMAGE TO COMPONENTS AND/OR PERSONAL INJURY.

WARNING

THIS PROCEDURE TO SERVICE THE FRAME HANGER IS PERFORMED WITH THE CLAMP GROUP, FRAME HANGER, AND TORQUE RODS ON THE OPPOSITE SIDE OF THE VEHICLE PROPERLY CONNECTED. FAILURE TO DO SO COULD ALLOW THE AXLES TO SHIFT RESULTING IN POSSIBLE DAMAGE TO COMPONENTS AND/OR PERSONAL INJURY. IF COMPONENTS ON BOTH SIDES OF THE VEHICLE ARE TO BE REMOVED IT WILL BE NECESSARY TO SUPPORT THE AXLE AND AXLE PINION TO KEEP THE AXLE FROM SHIFTING.

DISASSEMBLY

1. Chock the wheels.
2. Support the frame at ride height.

WARNING

PRIOR TO AND DURING DEFLATION AND INFLATION OF THE AIR SUSPENSION SYSTEM, ENSURE THAT ALL PERSONNEL AND EQUIPMENT ARE CLEAR FROM UNDER THE VEHICLE AND AROUND THE SERVICE AREA, FAILURE TO DO SO CAN CAUSE SERIOUS PERSONAL INJURY, DEATH, OR PROPERTY DAMAGE.

3. See additional Air Spring Warnings and Instructions in the Important Safety Notice Section of this publication prior to deflating or inflating the suspension system.
4. Disconnect the height control linkage assembly from the height control valve arm. Lower the height control valve arm to exhaust the air in the air springs and deflate the rear suspension. (See vehicle manufacturer's instructions).

NOTE

Prior to disassembly of the longitudinal torque rod fasteners, note the orientation and quantity of torque rod shims and pinion spacers (if equipped). It is required that the longitudinal torque rod shims and pinion spacer be installed in the same orientation and location as removed to preserve the existing alignment and pinion angles.

5. Remove the fasteners securing the longitudinal torque rod to the frame hanger.
6. Remove the fasteners securing the frame hanger to the frame rail. Remove frame hanger.

INSPECTION

1. Inspect the frame hanger, frame rail, longitudinal torque rods and cross member gussets for any signs of excessive wear, cracking or damage. See Preventive Maintenance section in this publication. Replace as necessary.

ASSEMBLY

NOTE

There are several different length fasteners used to connect the frame hanger to the frame rail. Verify the proper fastener length is used in the proper location. Refer to the vehicle manufacturer's specifications.

1. Position the frame hanger against the frame and loosely install the fasteners through the frame hanger, frame rail, and cross member gussets.

NOTE

It is required that the longitudinal torque rod shims and pinion spacers (if equipped) be installed in the same orientation and location as removed to preserve the existing alignment and pinion angles.

2. Install the longitudinal torque rod bolts through the torque rod bar pin holes, torque rod shims, pinion spacers (if equipped) and frame hanger. Verify the alignment shims are reinstalled in the same position as noted upon disassembly, see Figure 8-19. Loosely install the locknuts on the longitudinal torque rod bolts.
3. Tighten the frame hanger fasteners to vehicle manufacturer's specifications.

FIGURE 8-19

DRIVE TAG

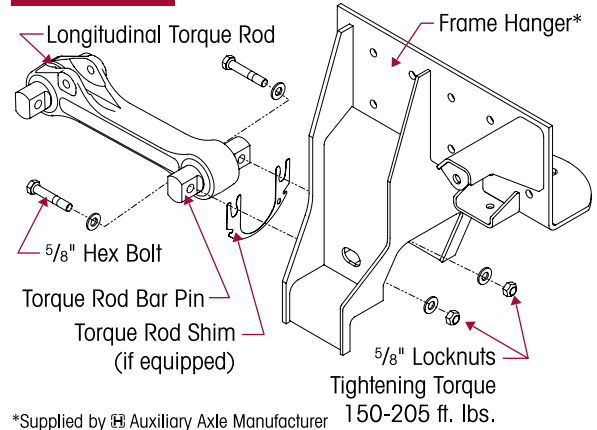

REAR ENGINE

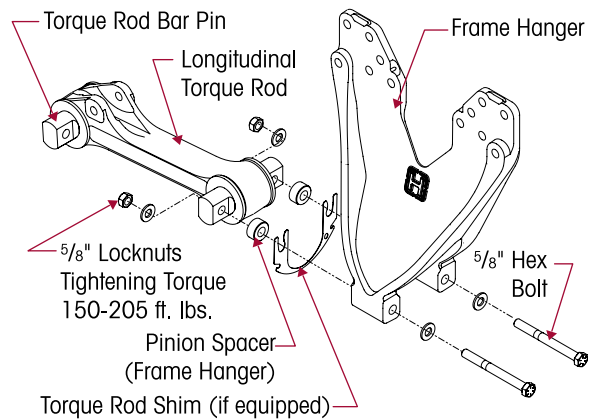

MID ENGINE

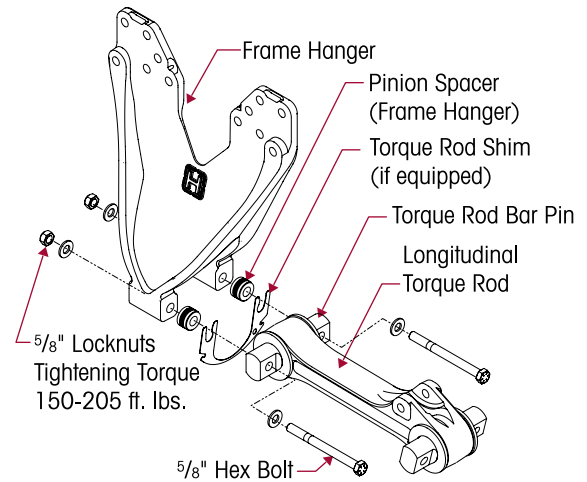

4. Tighten the longitudinal torque rod fasteners to 150-205 foot pounds torque.
5. See additional Air Spring Warnings and Instructions in the Important Safety Notice Section of this publication prior to deflating or inflating the suspension system.
6. Connect the height control arm to the height control valve linkage assembly to inflate the suspension.
7. Remove the frame supports.
8. Verify proper ride height adjustment, see Ride Height Adjustment in the Alignment & Adjustments Section of this publication. Correct as necessary.
9. Verify proper alignment of the axle. See Alignment in the Alignment & Adjustments Section of this publication. Correct as necessary.
10. Remove the wheel chocks.

CROSS MEMBER AND GUSSET

FIGURE 8-20

MID ENGINE

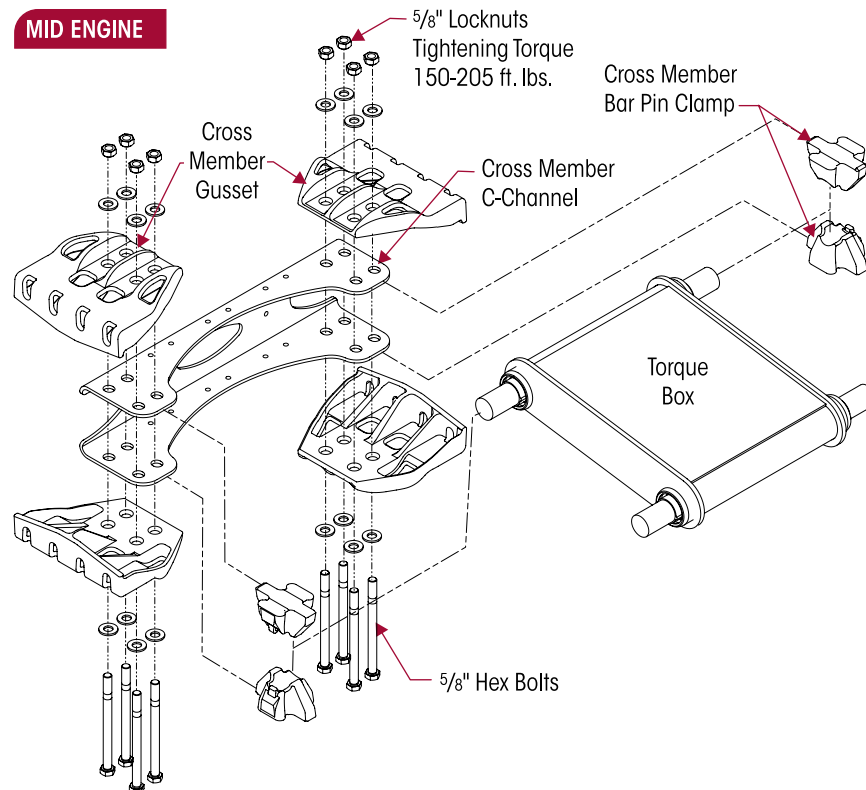

DISASSEMBLY

1. Chock the wheels.
2. Support the frame at ride height.



WARNING

PRIOR TO AND DURING DEFLATION AND INFLATION OF THE AIR SUSPENSION SYSTEM, ENSURE THAT ALL PERSONNEL AND EQUIPMENT ARE CLEAR FROM UNDER THE VEHICLE AND AROUND THE SERVICE AREA, FAILURE TO DO SO CAN CAUSE SERIOUS PERSONAL INJURY, DEATH, OR PROPERTY DAMAGE.

3. See additional Air Spring Warnings and Instructions in the Important Safety Notice Section of this publication prior to deflating or inflating the suspension system.
4. Disconnect the height control linkage assembly from the height control valve arm. Lower the height control valve arm to exhaust the air in the air springs and deflate the rear suspension. (See vehicle manufacturer's instructions).

**WARNING**

THE TORQUE BOX ALONG WITH THE TORQUE RODS RESTRAIN THE AXLE, PREVENTING AXLE MOVEMENT. PRIOR TO TORQUE BOX AND/OR TORQUE ROD DISASSEMBLY VERIFY THAT THE AXLE BEING SERVICED IS SUPPORTED UNDER THE PINION HOUSING/DIFFERENTIAL, SO THAT THE AXLE DOES NOT MOVE OR ROTATE. FAILURE TO DO SO CAN ALLOW THE AXLE TO ROTATE AND/OR SHIFT, CAUSING COMPONENT DAMAGE, AND/OR SEVERE PERSONAL INJURY.

5. Support the axle housing and pinion on the axle being serviced.
6. Remove the vertical fasteners which connect the torque box to the cross member, see Figure 8-20.
7. Remove the cross member bar pin clamps.
8. Remove the cross member C-channel.
9. Remove the fasteners securing the cross member gussets to the frame rails.
10. Remove the cross member gussets, see Figure 8-20.

INSPECTION

Inspect the cross member C-channel and gussets, frame rails, and frame hanger for signs of wear, cracking or damage. Replace as necessary. See Preventive Maintenance Section of this publication.

ASSEMBLY**NOTE**

There are several different length fasteners used to connect the frame hanger and cross member gussets to the frame rail. Verify the proper fastener length is used in the proper location. Refer to the vehicle manufacturer's specifications.

1. Position the cross member gussets against the frame rail. Loosely install the proper length fasteners through gussets, frame rail, and frame hangers.
2. Position the C-channel of the cross member between the cross member gussets.
3. Install the cross member bar pin clamps onto the torque box bar pin shaft.
4. Install the vertical clamp bolts through the cross member C-channel. Ensure the cross member bar pin clamps are between the vertical clamp bolts.
5. Tighten cross member gusset fasteners to the frame rail at 150-205 foot pounds torque.

**WARNING**

IT IS IMPORTANT THAT THE TORQUE BOX CLAMP CONNECTIONS BE TIGHTENED IN THE PROPER SEQUENCE AND HAVE THE PROPER TIGHTENING TORQUE VALUES MAINTAINED. FAILURE TO DO SO MAY RESULT IN THE DEFORMATION OF PARTS, RESULTING IN THE LOSS OF CLAMP FORCE, BOLT FAILURE, LOSS OF THE AXLE'S ALIGNMENT, LOSS OF VEHICLE CONTROL, PROPERTY DAMAGE, OR PERSONAL INJURY.

6. First snug, and then tighten the torque box to cross member clamp bolts in the proper sequence (inboard fasteners first then outboard fasteners), to prevent cross member deformation, see Figure 8-21. Tighten the locknuts to 150-205 foot pounds torque.

FIGURE 8-21

REAR ENGINE

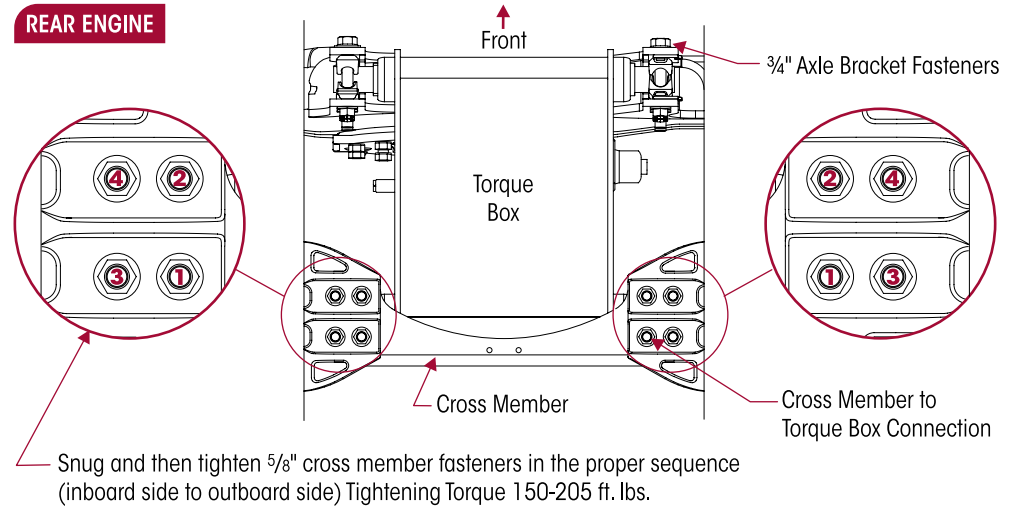

7. See additional Air Spring Warnings and Instructions in the Important Safety Notice Section of this publication prior to deflating or inflating the suspension system.
8. Connect the height control arm to the height control valve linkage assembly to inflate the suspension.
9. Remove the frame and the axle housing/differential supports.
10. Verify proper ride height adjustment, see Ride Height Adjustment in the Alignment & Adjustments Section of this publication. Correct as necessary.
11. Verify proper alignment of the axle, see Alignment in the Alignment & Adjustments Section of this publication. Correct as necessary.
12. Remove the Wheel chocks.



SECTION 9 Plumbing Diagram

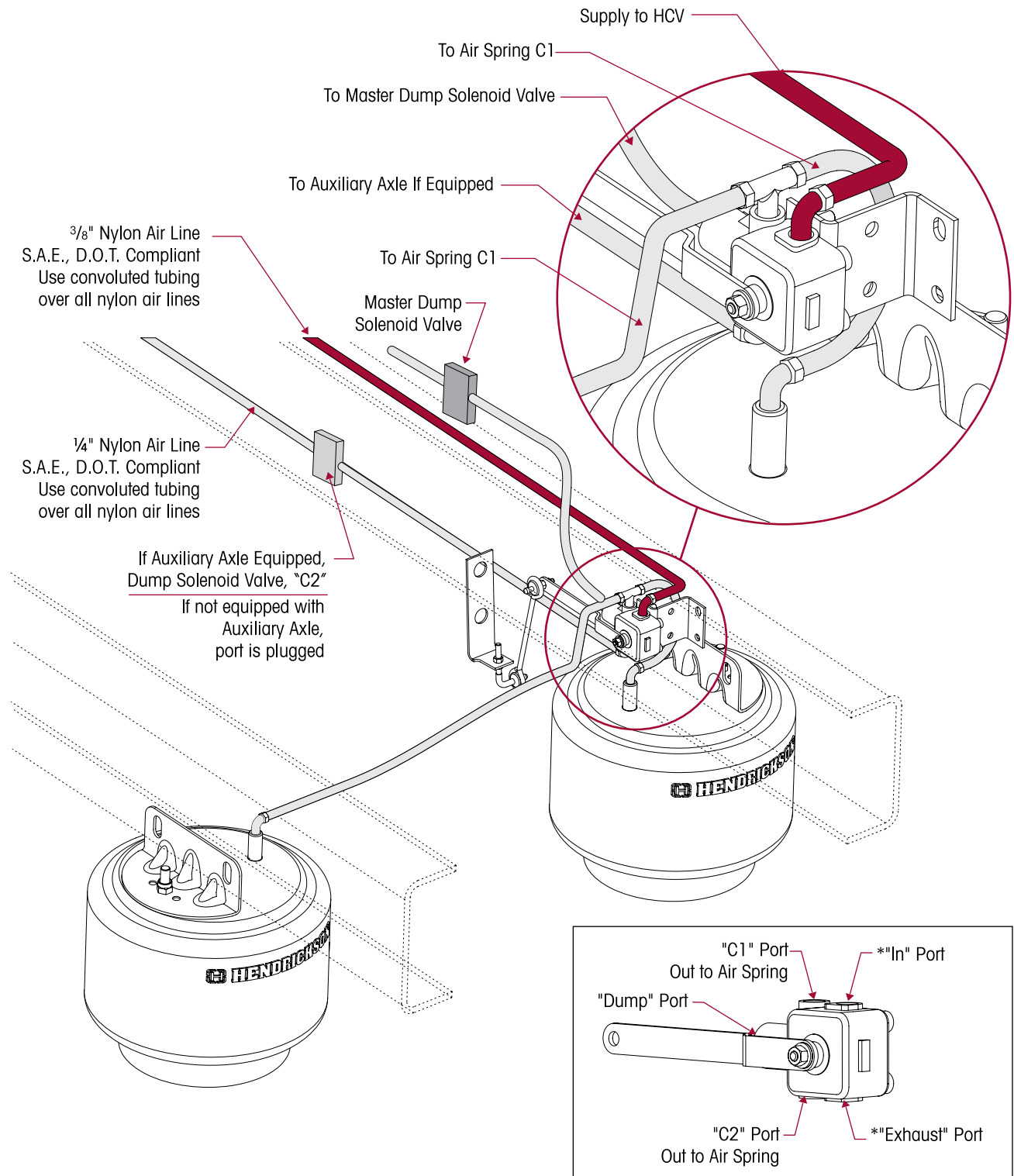

NOTE: * Air supply line can be connected to either "exhaust" or "in" port. For the mid engine application, the supply line is attached to the "exhaust" port.

SECTION 10 Torque Specifications

■ Mid Engine

HENDRICKSON RECOMMENDED TORQUE VALUES
PROVIDED IN FOOT POUNDS

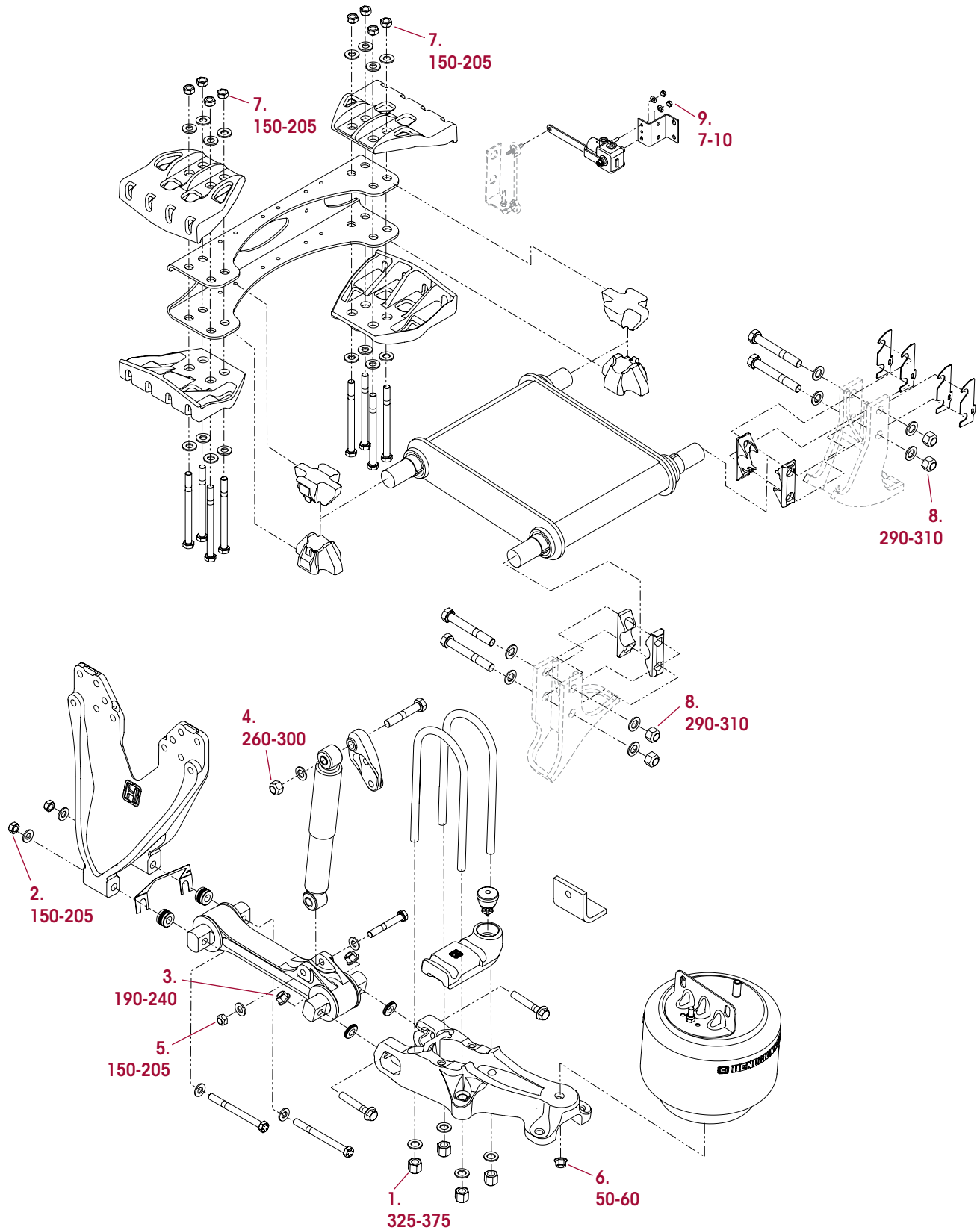



HTB 210 FOR SPARTAN MID ENGINE MOTORHOME CHASSIS

HENDRICKSON RECOMMENDED TORQUE SPECIFICATIONS				
NO.	COMPONENT	QUANTITY	***SIZE	*TORQUE VALUE in foot pounds
1.	U-bolt	8	¾"-16 UNF U-bolt Locknut	325-375
2.	Torque Rod to Frame Hanger	4	⅝"-11 UNC Locknut	150-205
3.	Torque Rod to Lower Air Spring Bracket	4	⅝"-11 UNC Flange Locknut	190-240
4.	Shock Absorber to Upper Hanger	2	¾"-10 UNC Locknut	260-300
5.	Shock Absorber to Torque Rod	2	⅝"-11 UNC Locknut	150-205
6.	Air Spring to Lower Air Spring Bracket	2	½"-13 UNC Flange Locknut	50-60
7.	Torque Box to Cross Member C-Channel	8	⅝"-11 UNC Locknut	150-205
8.	Torque Box to Axle Bracket	4	¾"-10 UNC Locknut	290-310
9.	Height Control Valve to HCV Bracket	2	¼"-20 UNC Locknut	7-10

NOTE: * Torque values listed above apply only if Hendrickson supplied fasteners are used. If non Hendrickson fasteners are used, follow torque specification listed in vehicle manufacturer's service manual.



■ Rear Engine

HENDRICKSON RECOMMENDED TORQUE VALUES
PROVIDED IN FOOT POUNDS

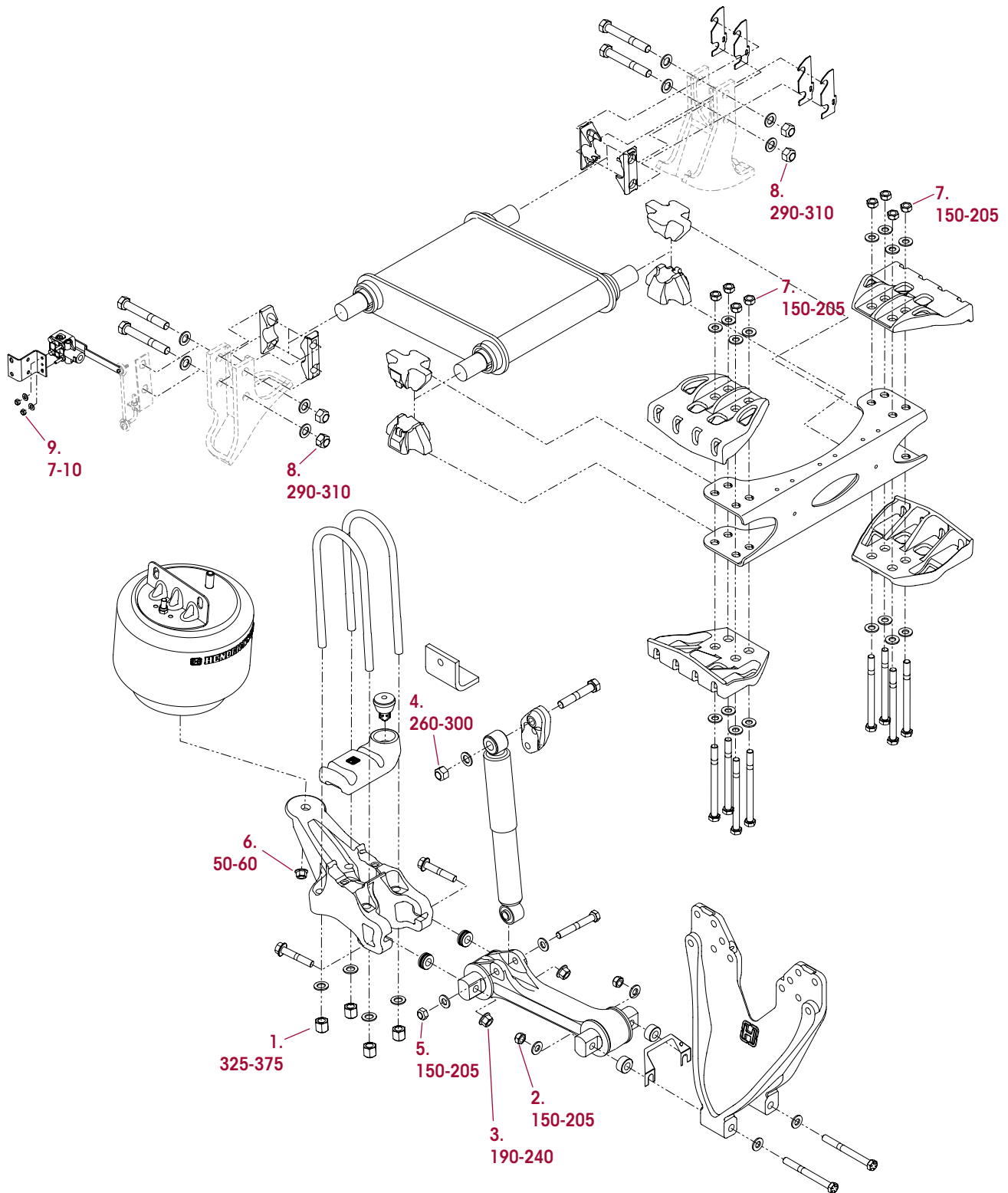



HTB 210 FOR SPARTAN REAR ENGINE MOTORHOME CHASSIS

HENDRICKSON RECOMMENDED TORQUE SPECIFICATIONS				
NO.	COMPONENT	QUANTITY	***SIZE	*TORQUE VALUE in foot pounds
1.	U-bolt	8	¾"-16 UNF U-bolt Locknut	325-375
2.	Torque Rod to Frame Hanger	4	⅝"-11 UNC Locknut	150-205
3.	Torque Rod to Lower Air Spring Bracket	4	⅝"-11 UNC Flange Locknut	190-240
4.	Shock Absorber to Upper Hanger	2	¾"-10 UNC Locknut	260-300
5.	Shock Absorber to Torque Rod	2	⅝"-11 UNC Locknut	150-205
6.	Air Spring to Lower Air Spring Bracket	2	½"-13 UNC Flange Locknut	50-60
7.	Torque Box to Cross Member C-Channel	8	⅝"-11 UNC Locknut	150-205
8.	Torque Box to Axle Bracket	4	¾"-10 UNC Locknut	290-310
9.	Height Control Valve to HCV Bracket	2	¼"-20 UNC Locknut	7-10

NOTE: * Torque values listed above apply only if Hendrickson supplied fasteners are used. If non Hendrickson fasteners are used, follow torque specification listed in vehicle manufacturer's service manual.

■ Drive Tag

HENDRICKSON RECOMMENDED TORQUE VALUES
PROVIDED IN FOOT POUNDS

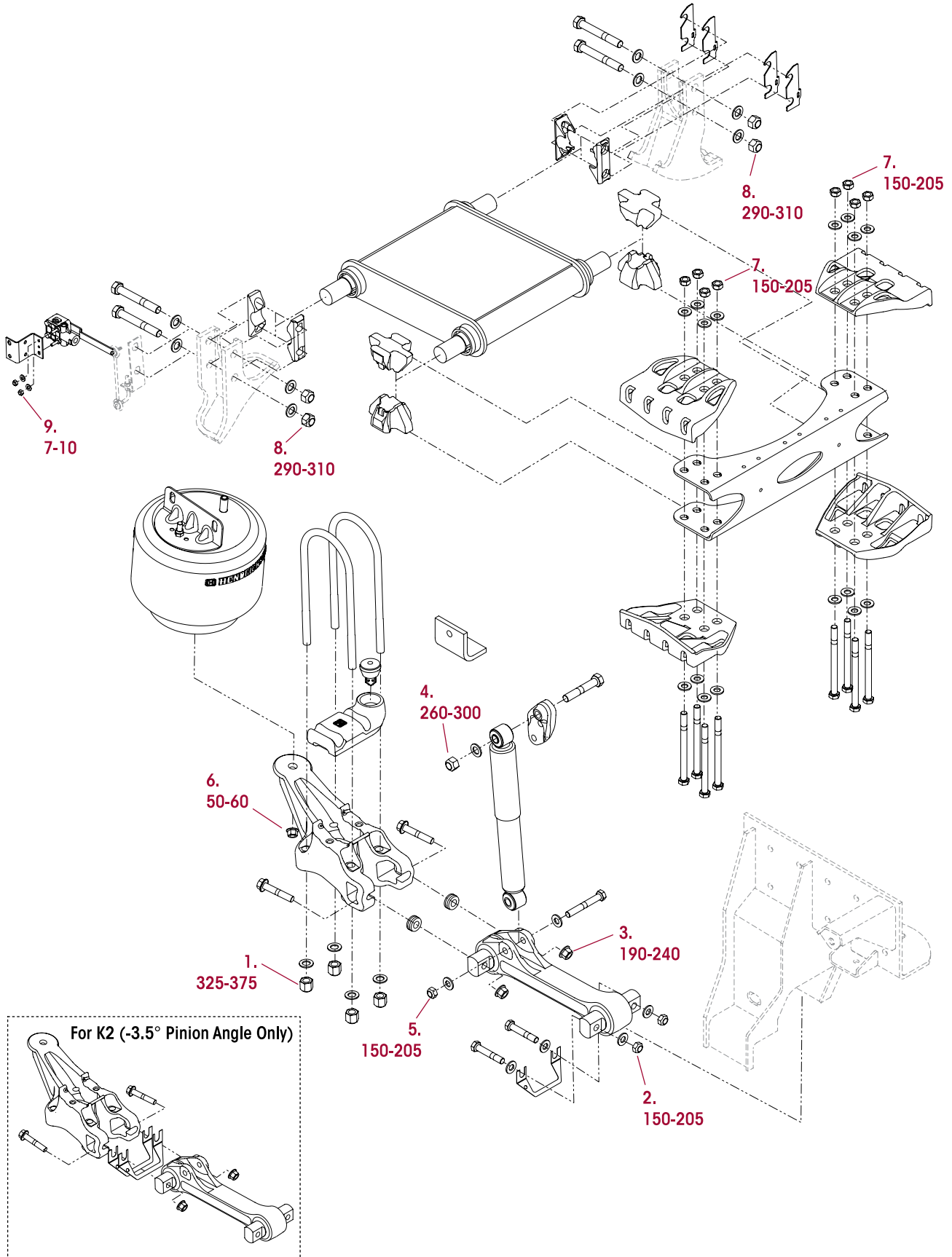



HTB 210 FOR SPARTAN DRIVE TAG MOTORHOME CHASSIS

HENDRICKSON RECOMMENDED TORQUE SPECIFICATIONS				
NO.	COMPONENT	QUANTITY	***SIZE	*TORQUE VALUE in foot pounds
1.	U-bolt	8	¾"-16 UNF U-bolt Locknut	325-375
2.	Torque Rod to Frame Hanger	4	⅝"-11 UNC Locknut	150-205
3.	Torque Rod to Lower Air Spring Bracket	4	⅝"-11 UNC Flange Locknut	190-240
4.	Shock Absorber to Upper Hanger	2	¾"-10 UNC Locknut	260-300
5.	Shock Absorber to Torque Rod	2	⅝"-11 UNC Locknut	150-205
6.	Air Spring to Lower Air Spring Bracket	2	½"-13 UNC Flange Locknut	50-60
7.	Torque Box to Cross Member C-Channel	8	⅝"-11 UNC Locknut	150-205
8.	Torque Box to Axle Bracket	4	¾"-10 UNC Locknut	290-310
9.	Height Control Valve to HCV Bracket	2	¼"-20 UNC Locknut	7-10

NOTE: * Torque values listed above apply only if Hendrickson supplied fasteners are used. If non Hendrickson fasteners are used, follow torque specification listed in vehicle manufacturer's service manual.

AUXILIARY AXLE DRIVE TAG

The components illustrated on this page are supplied by Hendrickson Specialty Products-Auxiliary Axle Systems. For information regarding component replacement or technical service call 1-800-660-2829.

**HENDRICKSON RECOMMENDED TORQUE VALUES
PROVIDED IN FOOT POUNDS**

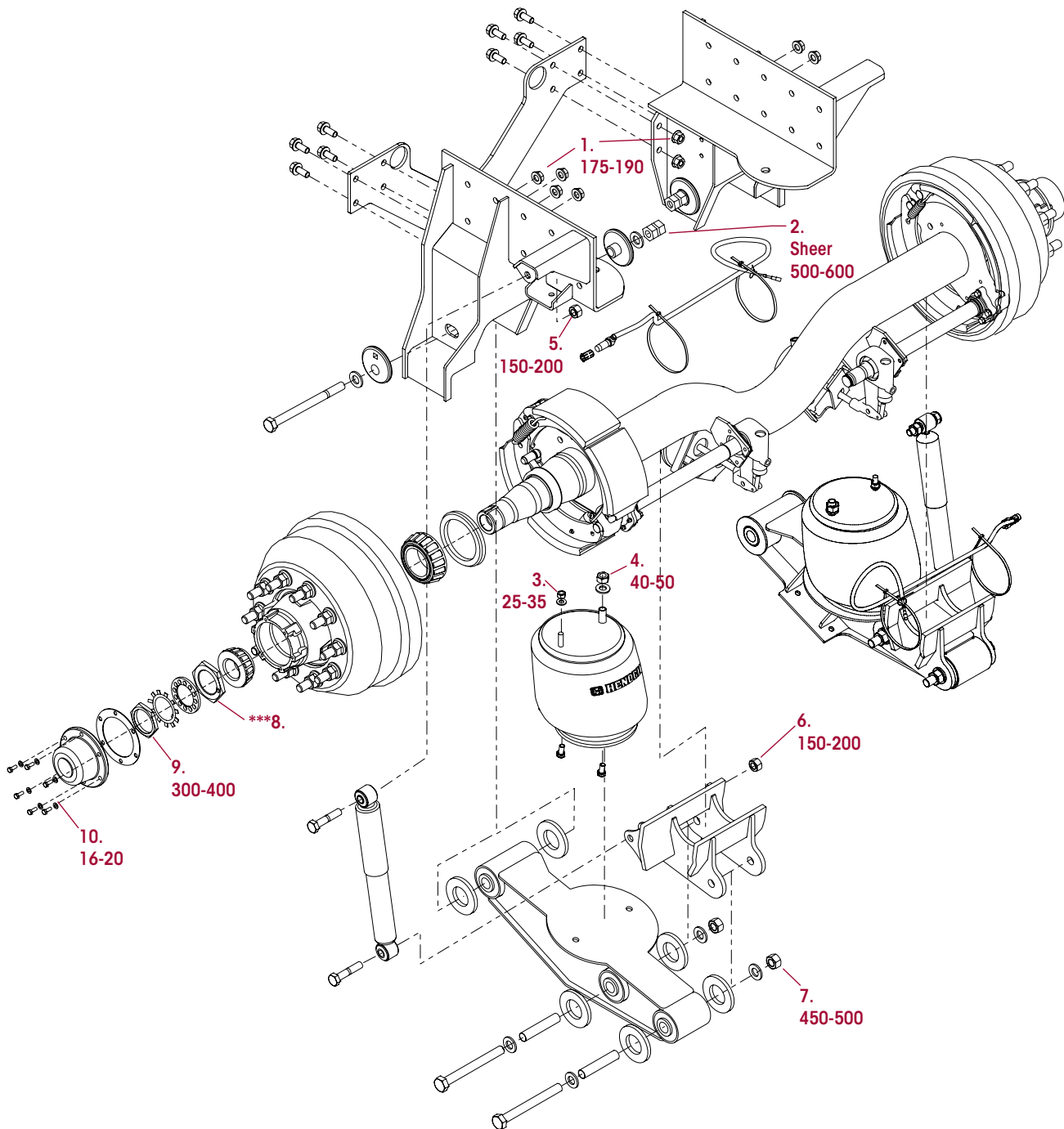

***AUXILIARY AXLE DRIVE TAG FOR SPARTAN MOTORHOME CHASSIS**

HENDRICKSON RECOMMENDED TORQUE SPECIFICATIONS				
NO.	COMPONENT	QUANTITY	***SIZE	*TORQUE VALUE in foot pounds
1.	Hanger Bracket Assembly to Cross Member	8	5/8"-11 Hex Nut	175-190
2.	QUIK-ALIGN® Torq-Rite® Nut	2	7/8"-9 Sheer Nut	Sheer 500-600
3.	Air Spring to Outboard Hanger Bracket Assembly	2	1/2"-13 Hex Nut	25-35
4.	Air Spring to Inboard Hanger Bracket Assembly	2	3/4"-16 Hex Nut	40-50
5.	Upper Shock Absorber to Hanger Bracket Assembly	2	3/4"-10 Hex Nut	150-200
6.	Lower Shock Absorber to Beam Axle Assembly	2	3/4"-10 Hex Nut	150-200
7.	Axle Seat Weldment to Beam Assembly	4	7/8"-9 Hex Nut	450-500
8.	Inner Wheel Bearing Adjusting Nut	2	2 5/8"-16 Nut	***
9.	Outer Wheel Bearing Nut	2	2 5/8"-16 Nut	300-400
10.	Hub Cap	12	5/16"-18 UNC Hex Bolt	16-20
NOTE	<p>* The components listed on this page are supplied by Hendrickson Auxiliary Axle Systems. For information regarding component replacement or technical service call 1-800-660-2829.</p> <p>** Torque values listed above apply only if Hendrickson supplied fasteners are used. If non Hendrickson fasteners are used, follow torque specification listed in vehicle manufacturer's service manual.</p> <p>*** See Wheel Bearing Adjustment in the Alignment & Adjustments Section of this publication for proper torque procedure.</p>			



SECTION 11

Troubleshooting Guide

*HTB 210 TROUBLESHOOTING GUIDE

CONDITION	POSSIBLE CAUSE	CORRECTION
Suspension has harsh or bumpy ride	Air spring not inflated to specification or damaged	Repair air system and check ride height, see Ride Height Adjustment in the Alignment & Adjustments Section.
	Ride height set incorrectly	Adjust ride height to proper setting, see Ride Height Adjustment in the Alignment & Adjustments Section.
	Suspension is overloaded	Redistribute load to eliminate overloaded condition.
Irregular tire wear	Incorrect tire inflation pressure	Correct tire pressure per vehicle manufacturer and tire manufacturer specifications.
	Axle Alignment	Check vehicle alignment. Adjust if necessary, see Alignment & Adjustments Section.
	Worn torque box bushings	Replace torque box as necessary.
	Worn torque rod bushings	Replace torque rod bushings as necessary.
Excessive driveline vibration	Incorrect pinion angle	Adjust pinion angle, refer to the vehicle manufacturer for specifications.
	Ride height set incorrectly	Adjust ride height to proper setting, see Ride Height Adjustment in the Alignment & Adjustments Section.
	Air spring not inflated to specification or damaged	Repair air system and check ride height, see Ride Height Adjustment in the Alignment & Adjustments Section.
Suspension is noisy	Broken shock or loose shock	Check fasteners for proper torque requirements and inspect for damage. See Preventive Maintenance Section of this publication. Replace as necessary.
	Worn torque box bushings	Replace torque box as necessary.
	Loose U-bolt	Tighten U-bolt to specifications, see Preventive Maintenance Section.
	Worn torque rod bushings	Replace torque rod bushings as necessary.
Vehicle bouncing excessively	Damaged or leaking shock absorber	Replace shock absorber.
	Ride height set incorrectly	Adjust ride height to proper setting. See Ride Height Adjustment in the Alignment & Adjustments Section.
Vehicle leaning	Incorrect tire inflation pressure	Correct tire pressure per vehicle manufacturer and tire manufacturer specifications.
	Load not centered	Redistribute load to eliminate load imbalance.
	Frame twisted	Straighten the frame per vehicle manufacturer guidelines.
	Air spring not inflated to specification or damaged	Repair air system and check ride height, see Ride Height Adjustment in the Alignment & Adjustments Section.
	Axle housing bent or broken	Replace axle housing per vehicle manufacturer guidelines and align vehicle.
	Loose U-bolt	Tighten U-bolt to specifications, see Preventive Maintenance Section.
	Front suspension	Inspect and repair front suspension.

* Troubleshooting for components supplied by Hendrickson Specialty Products - Auxiliary Axle Systems, call **1-800-660-2829**.

www.hendrickson-intl.com



Truck Commercial Vehicle Systems
800 South Frontage Road
Woodridge, IL 60517-4904 USA

1.866.755.5968 (Toll-free U.S. and Canada)
1.630.910.2800 (Outside U.S. and Canada)
Fax 1.630.910.2899