

For complete instructions, refer to Hendrickson literature number **T51002** TIREMAAX® PRO and CP *Installation, Service and Troubleshooting* procedures before referencing this document.

HUBCAP INSTALLATION

IMPORTANT: Once installed, **DO NOT REMOVE HUBCAP.** To protect the warranty on Hendrickson assembled wheel-end components, follow tire hose installation instructions in T51002. CONTACT Hendrickson Technical Services before removing any Hendrickson assembled wheel-end components.

Three basic hubcap types, as noted in the table below, are available. Hubcap installation is identical for each.

SPINDLE TYPE	HUBCAP
HN	HN
HP	HP
HP with castle nut system	HP extended

Table 1: Basic hubcap types

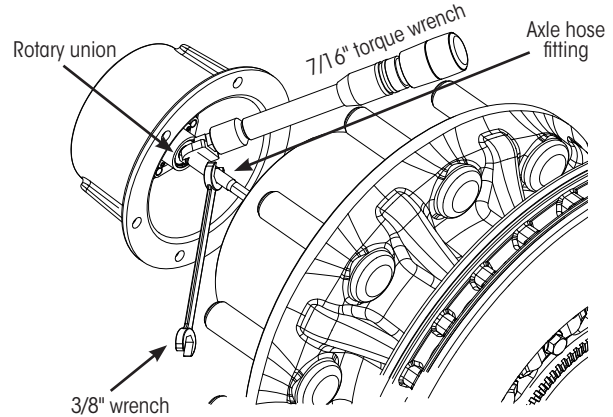

Figure 1: Hubcap to axle hose connection

To install the hubcap:

- 1. Draw** just enough axle hose out from center of spindle to attach axle hose fitting to the rotary union inside the hubcap (Figure 1).
- 2. Place** hubcap gasket over axle hose for later positioning.

NOTE: Shaft has pre-applied dry thread locker. Loctite® or other thread locking compound is not required.

- 3. Hand thread** rotary union onto axle hose fitting. **DO NOT rotate axle hose fitting.**
- 4. Using** a 3/8-inch wrench to prevent rotation of the axle hose fitting (Figure 1), **tighten** the rotary union shaft to 50±5 in. lbs. (5.7±0.6 Nm) of torque.
- 5. Place** two opposing bolts in hubcap and **align** gasket to bolts.
- 6. Orient** hubcap for proper tire hose routing. **Aligning** the tire hose ports so they are **BETWEEN** two wheel mounting studs will generally provide the best tire hose routing (Figure 4).
- 7. Install** all hubcap bolts and **hand-tighten.**

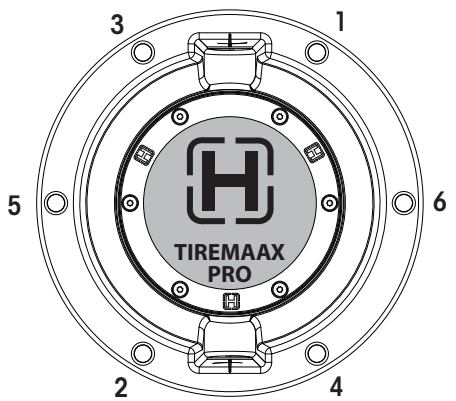

Figure 2: 6-bolt hubcap torque pattern

- 8. Tighten** hubcap bolts in the order shown to 15±3 ft. lbs. (20±4 Nm) of torque (Figure 2).
- 9. Repeat** procedure for each wheel-end.

NOTE: If oil lubricated wheel-end, **oil can be added after hubcap is installed.** For details on wheel-end lubrication, refer to applicable wheel-end or OE documentation.

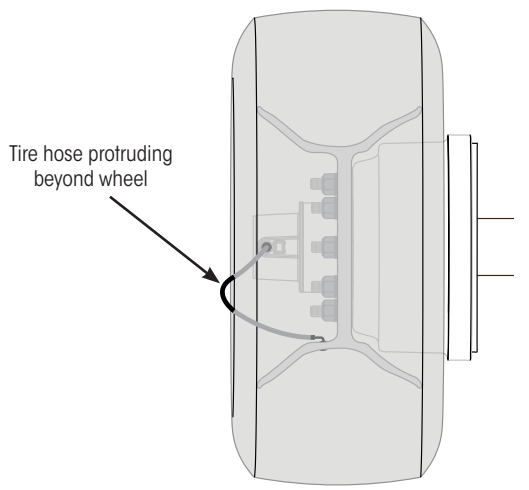

Figure 3: Improper tire hose installation (super single shown)

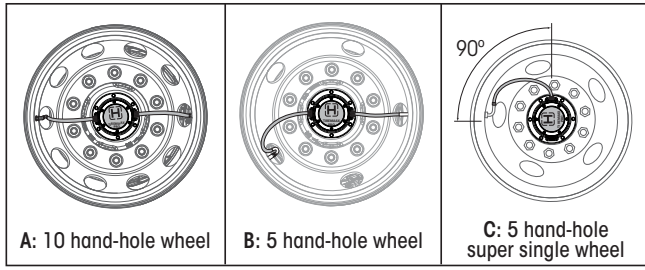

Figure 4: Properly clocking hubcaps and wheels helps prevent tire hose damage during operation.

When clocking hubcaps / wheels:

- 1. Ensure** hubcap is clocked to aim tire hose ports between wheel studs.
- 2. Clock** wheels to align valve stem with hubcap tire hose port(s). If duals, align inner wheel (straight hose) first.

When installing tire hoses, ensure:

- Tire hose is not stretched so tightly a strain is introduced at either end.
- Either tire hose is not so loose it contacts the wheel.
- No portion of the tire hose extends outward past the wheel (Figure 3).

www.hendrickson-intl.com
HENDRICKSON TRAILER COMMERCIAL VEHICLE SYSTEMS
 2070 Industrial Place SE
 Canton, OH 44707-2641 USA