

# **H** TECHNICAL PROCEDURE

## **TRAILER SUSPENSION, AXLE, WHEEL-END, & BRAKE SYSTEMS**

**SUBJECT:** General Safety Precautions and  
Information for Technical Procedures

**LIT NO:** T12007

**DATE:** April 2018

---



### **TABLE OF CONTENTS**

<b>Important Safety Information .....</b>	<b>2</b>
Explanation of Signal Words .....	2
General Safety Precautions.....	2
Personal Protection Guidelines .....	3
Use of Fasteners .....	3
Wheel-End and Brake Service Considerations .....	4
Precautions While Welding.....	4
<b>Miscellaneous .....</b>	<b>5</b>
When Performing A Procedure .....	5
Before You Begin A Procedure.....	5
Contacting Hendrickson.....	6
<b>Preparing Trailer for Service.....</b>	<b>7</b>

Proper installation, maintenance, service, inspection and repairs are important to help ensure safe, reliable operation of Hendrickson equipment. The information in this document shall apply to Hendrickson Trailer Technical Services literature that provides instructional procedures for the purpose of installing, maintaining, servicing, inspecting or repairing Hendrickson Trailer suspension, axle, wheel-end and brake systems and related components. This document provides additional safety information and important guidelines.

## IMPORTANT SAFETY INFORMATION

**WARNINGS, CAUTIONS, NOTICES, NOTES** and other **IMPORTANT statements** included in this and other technical literature should be read carefully to help prevent personal injury or damage to equipment and property.

Prior to performing technical procedures, it is important to read, understand and to follow the safety related information within this and other applicable Hendrickson technical publications.

## EXPLANATION OF SIGNAL WORDS

Hazard signal words (such as DANGER, WARNING or CAUTION) appear in various locations throughout this and other applicable Hendrickson technical publications. Information accented by one of these signal words must be observed at all times. Additional notes are utilized to emphasize areas of procedural importance and provide suggestions for ease of repair. The following definitions comply with ANSI Z535.4 and indicate the use of safety signal words as they appear throughout the publication.

 **DANGER: INDICATES IMMEDIATE HAZARDS WHICH WILL RESULT IN SEVERE PERSONAL INJURY OR DEATH.**

 **WARNING: Indicates hazards or unsafe practices which could result in severe personal injury or death.**

 **CAUTION: Indicates a hazardous situation which, if not avoided, may result in minor or moderate injury.**

**NOTICE: Indicates hazards or unsafe practices which could result in damage to machine or equipment.**

**IMPORTANT:** An operating procedure, practice or condition that is essential to emphasize.





Safety alert symbol - used to indicate a condition exists that may result in personal injury or harm to individuals. It must be applied to DANGER, WARNING and CAUTION statements, which emphasize severity.

## GENERAL SAFETY PRECAUTIONS

 **WARNING: Improper maintenance, service or repair can cause damage to the vehicle and other property, personal injury, unsafe operating conditions and potentially void the manufacturer's warranty.**

 **WARNING: DO NOT modify or rework parts without written authorization from Hendrickson. Use ONLY Hendrickson-authorized replacement parts. Use of modified or non-genuine replacement parts not authorized by Hendrickson may not meet Hendrickson's specifications. It can also result in failure of the part, adverse vehicle handling and possible personal injury or property damage.**

 **WARNING: Adhere to the published capacity ratings for the suspensions. Add-on axle attachments (e.g. sliding fifth wheels) and other load transferring devices can increase the suspension load above the rated and approved capacities which could result in component damage and adverse vehicle handling, possibly causing personal injury or property damage.**

 **WARNING: Exercise extreme care when handling or performing maintenance in the area of the axle/beam assembly. DO NOT nick or gouge the axle/beam assembly. Such improper actions can cause the axle/beam assembly to fail and can cause adverse vehicle handling, possible personal injury or property damage.**

 **WARNING: DO NOT operate the trailer without reinflating the suspension and releasing the trailer parking brakes.**

**⚠CAUTION:** DO NOT apply undercoating, paint or other surface coating to the suspension and frame brackets until completing the alignment as defined in Hendrickson literature number **L579 Alignment Procedures**. Doing so will result in incorrect clamp load of pivot connection hardware.

**NOTICE:** Pressure or steam washing should be avoided near grease seals as water could be forced past the seal and degrade lubricant performance.

**IMPORTANT:** Safety Data Sheets (SDS) for certain third party supplied components are available online from Hendrickson at [www.hendrickson-intl.com/TrailerLit](http://www.hendrickson-intl.com/TrailerLit).

## PERSONAL PROTECTION GUIDELINES

**⚠WARNING:** Always wear proper eye protection and other required personal protective equipment (PPE) when performing vehicle maintenance, service or repairs. Follow applicable federal, state and local safety regulations and shop safety rules.

**⚠WARNING:** Protect eyes and skin from particle penetration when using low or high air pressure.

**⚠WARNING:** Solvent cleaners can be flammable, poisonous and cause burns. To help avoid serious personal injury, carefully follow the manufacturer's product literature and the following procedures:

- Wear proper eye protection.
- Wear clothing that protects your skin.
- Work in a well-ventilated area.
- DO NOT use gasoline (hydrocarbon based) or other flammable cleaning solvents to clean the suspension, axle, wheel-end or brake components. These solvents can explode, burn or disperse harmful vapors.

- Hot solution tanks or alkaline solutions must be used correctly. Follow the manufacturer's recommended instructions and guidelines carefully to help prevent personal injury.

**⚠CAUTION:** A mechanic using a service procedure or tool that has not been recommended by Hendrickson, must confirm that neither his safety, the safety of others nor the vehicle's safety will be jeopardized by the method or tool selected. Individuals deviating in any manner from the provided instructions assume all risks of consequential personal injury or damage to equipment.

## USE OF FASTENERS

**⚠WARNING:** Loose or over torqued fasteners can cause component damage, adverse vehicle handling, property damage, or severe personal injury. Maintain correct torque value at all times. Check torque values on a regular basis as specified.

**NOTICE:** Hendrickson does not recommend reusing used fasteners because the metal and threads are stressed when tightened. Duplicating clamp loads under torque is not assured with used fasteners.

**IMPORTANT:** DO NOT apply additional lubricant to fastener threads (e.g. anti-seize, paint, undercoat, etc.). Doing so will reduce the friction between fastener components which can lead to overtightening, unpredictable clamp loads, and unreliable fastener connections.

## WHEEL-END AND BRAKE SERVICE CONSIDERATIONS

**⚠CAUTION:** Major wheel-end components are heavy and difficult to lift by hand. Use appropriate hoist and support slings to lift into position.

**DO NOT** lift an air disc brake (ADB) caliper assembly by the brake pad retainer bracket.

**⚠WARNING:** Brake linings contain non-asbestos fibers. Wear approved eye protection and respirator when working on or near the brakes to prevent a possible health hazard. The following precautions and considerations should be applied when handling brake lining:

- Follow applicable federal, state, local and shop safe practices for working with and disposal of brake lining materials.
- Workers should wash before eating, drinking or smoking; shower after working and should not wear work clothes home. Work clothes should be vacuumed and laundered separately without shaking.
- Hendrickson recommends that workers doing brake work should take steps to minimize exposure to airborne brake lining particles. Proper procedures to reduce exposure include:
  - **DO NOT** use compressed air or dry brushing for cleaning brake assemblies or work areas.
  - Work in a well-ventilated area,
  - Segregate areas where brake work is done,
  - Use local filtered ventilation systems or enclosed cells with filtered vacuums.

- Avoid creating dust. Dust from brake pads and parts is a possible cancer and lung disease hazard. Long term affects of some non-asbestos fibers have not been determined. Current OSHA Regulations cover exposure levels to some components of non-asbestos linings but not all.
- While Hendrickson does not offer asbestos brake linings, certain aftermarket brake linings supplied by others may contain asbestos. Use only Hendrickson authorized replacement parts.

**⚠WARNING:** A damaged brake chamber can cause the brake system to not operate properly. It can also result in serious or fatal injury during handling and use.

**⚠CAUTION:** To avoid injury and damage to brake components, manually cage the brake chamber prior to servicing brake.

**NOTICE:** Accessory-type hubcaps, such as the chrome "top hat" style hubcap, increase wheel-end temperatures during operation and are not recommended for use on Hendrickson HLS<sup>®</sup>, HVS<sup>®</sup>, HUS<sup>®</sup>, HXL3<sup>®</sup>, HXL5<sup>®</sup> or HXL7<sup>®</sup> extended-service wheel ends.

## PRECAUTIONS WHILE WELDING

**⚠WARNING:** The following safety notices apply when welding on Hendrickson suspension components:

- **DO NOT** use heat near the axle/beam assembly unless specifically instructed to do so.
- **DO NOT** use a cutting torch to remove any attaching fasteners. The use of heat on suspension components will adversely affect the strength of these parts. A component damaged in this manner can result in the adverse vehicle handling and possible personal injury or property damage.

- **DO NOT strike an arc with the electrode on the axle/beam assembly unless specifically authorized to do so in writing by Hendrickson.**

**⚠CAUTION: When welding, place electrodes such that current does not flow through wheel bearings. A connection that places a wheel bearing between the ground cable connection and the weld area can damage the bearing by electric arcing.**

## MISCELLANEOUS

Hendrickson strongly recommends **no modifications** be made to its equipment or related components without its prior written authorization. Any and all such unauthorized modifications of Hendrickson equipment or related components:

- Are to be considered an improper and impermissible modification and misuse of the product;
- Will immediately void the Hendrickson warranty;
- May adversely affect the performance, durability and overall integrity of the product; and
- Are made at the risk of the party conducting such unauthorized modification.

## WHEN PERFORMING A PROCEDURE

- Work must be carried out by licensed or trained personnel.
- Sudden release of parking springs (e.g. the spring brake part of the brake chamber or the brake return spring) may cause injury.
- Use recommended tools only.
- Before releasing trailer back into service, perform operational checks and test the trailer to ensure brakes and other systems are working correctly.

## BEFORE YOU BEGIN A PROCEDURE

Hendrickson provides a variety of technical publications regarding the proper installation, service, and repair of its equipment and related components. Consult Hendrickson website

([www.Hendrickson-intl.com/TrailerLit](http://www.Hendrickson-intl.com/TrailerLit))

for the latest version of this and other applicable technical publications. Hendrickson reserves the right to make changes and improvements to its products and publications at any time.

Before conducting any work on any of our products; please read, understand and comply with:

- This and all other applicable Hendrickson technical publications.
- All signal word (e.g. CAUTION, WARNING and DANGER) statements to help avoid personal injury and damage to equipment or property.
- Vehicle manufacturer's maintenance, service, installation and safety instructions.
- All applicable federal, state and local safety regulations.
- All applicable fleet/shop safety rules.

## CONTACTING HENDRICKSON

Contact Hendrickson Trailer Technical Services for technical assistance as needed. To do so, several options are available as listed below. Technical Services must be contacted before performing any warranty related service.

Prior to contacting Technical Services, it is best to have the following information available, as applicable, about the particular vehicle and Hendrickson suspension:

- Suspension ID Tag information (Refer to Hendrickson Literature Number *L977 Trailer Suspension and Axle ID Guide*, page 2 for tag location and details):
  - Suspension model number
  - Suspension serial number
- VIN plate data. Refer to trailer OEM manual for VIN plate location.
  - Trailer Type (van, reefer, flat bed, etc.)
  - Manufacturer
  - VIN (vehicle identification number)
  - In-service date<sup>1</sup>
- Approximate number of suspension miles (optional).
- If applicable, description of the system problem, part number and part description of the reported non-functioning part.
  - Date of problem
  - Where applicable: location of problem on suspension/trailer (e.g., road side, front axle, rear axle, curb side rear, etc.)
  - Symptoms-
    - » Systems, components or function affected by the problem?
    - » When does the problem occur?
    - » How often does the problem occur?
    - » Etc.
- Any troubleshooting and measurements that have been performed.
- Digital photos of suspension and damaged areas.
- Special application approval documentation (if applicable).

<sup>1</sup> If the in-service date is unknown or not available, the vehicle date of manufacture can be substituted.

## PHONE

Contact Hendrickson directly in the United States and Canada at **866-RIDEAIR (743-3247)**. From the menu, select:

- **Technical Services/Warranty** for technical information.
- Other selections include:
  - **Aftermarket Sales** for replacement parts information and ordering.
  - **Original Equipment Sales** for parts inquiries and ordering for trailer manufacturers.

## EMAIL

To contact Hendrickson Trailer Technical Services, use the following e-mail address:

**HTTS@hendrickson-intl.com**

## PREPARING TRAILER FOR SERVICE

**NOTE: DO NOT** service a suspension or any components that is under warranty without first contacting Hendrickson Technical Services. Refer to CONTACTING HENDRICKSON for details.

**⚠WARNING:** To prevent serious eye injury, always wear safety glasses when performing trailer maintenance and service.

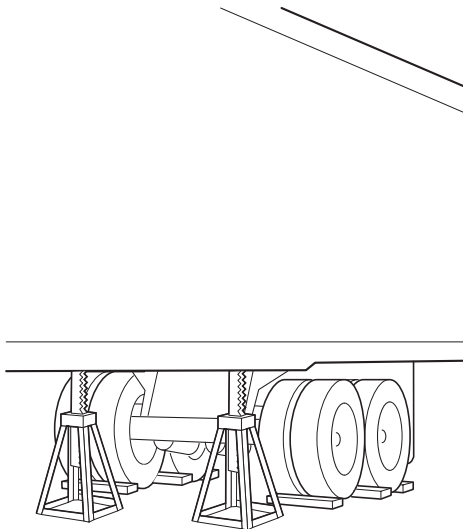

*Figure 1: Trailer preparation*

1. **Park** the trailer on a level, debris-free surface.
2. **Set** the trailer parking brakes.
3. To prevent the trailer from moving, **chock** the wheels of an axle not being raised.
4. **Exhaust** the air from the trailer suspension.

If required during service:

5. **Release** the trailer parking brakes.
6. Using a jack, **raise** trailer or axle until wheels clear the work surface.
7. **Support** the raised trailer with safety stands.

**⚠WARNING:** **DO NOT** work under a trailer supported only by jacks. Jacks can slip or fall over, resulting in serious personal injury. Always use safety stands to support a raised trailer.

Call Hendrickson at **866.RIDEAIR (743.3247)** for additional information.



**TRAILER COMMERCIAL VEHICLE SYSTEMS**

2070 Industrial Place SE  
Canton, OH 44707-2641 USA  
866.RIDEAIR (743.3247)  
330.489.0045 • Fax 800.696.4416

**Hendrickson Canada**

250 Chrysler Drive, Unit #3  
Brampton, ON Canada L6S 6B6  
800.668.5360  
905.789.1030 • Fax 905.789.1033

**Hendrickson Mexicana**

Circuito El Marqués Sur #29  
Parque Industrial El Marqués  
Pob. El Colorado, Municipio El Marqués,  
Querétaro, México C.P. 76246  
+52 (442) 296.3600 • Fax +52 (442) 296.3601

[www.hendrickson-intl.com](http://www.hendrickson-intl.com)