



Driven By You



**Integrated Front Spring Suspension  
and Steer Axle System**

## **SOFTEK® enhances ride, handling and durability while reducing maintenance**

The advanced spring design of the SOFTEK integrated front mechanical suspension and steer axle system produces increased roll stability during cornering and crosswinds, providing a more stable platform. The design also delivers exceptional ride and handling for driver and passenger comfort, proving ideal for motorhome applications.

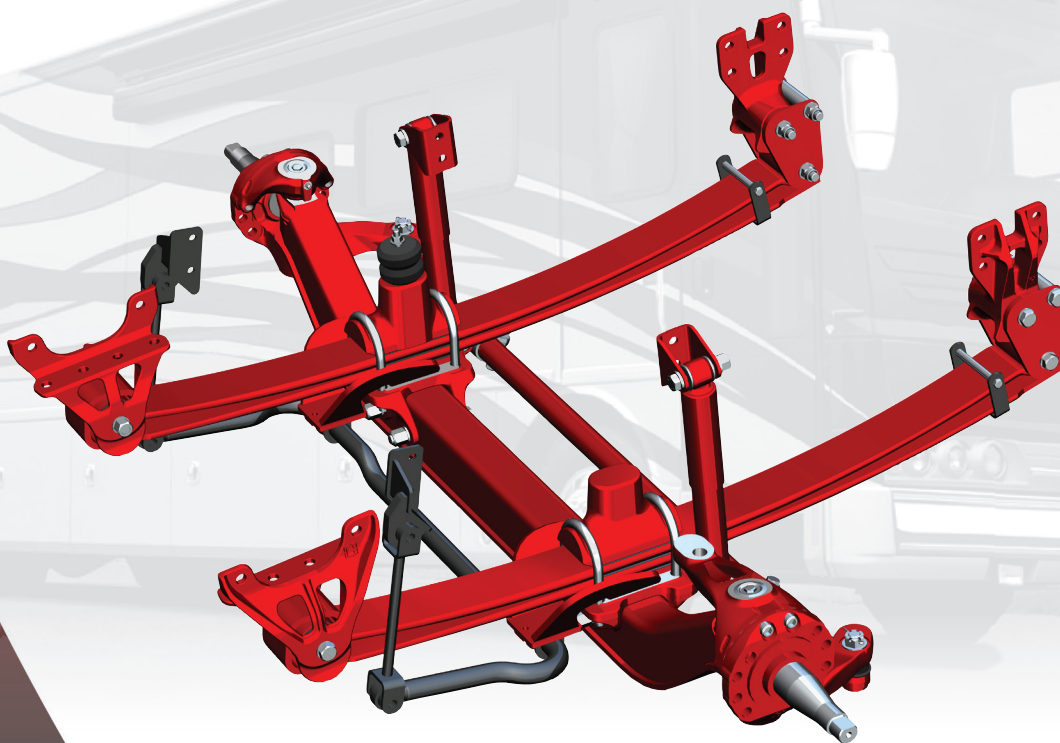

For additional information, call **630.910.2800** or visit our web site at **[www.hendrickson-intl.com](http://www.hendrickson-intl.com)**



*The World Rides On Us®*

**SOFTEK®** — Utilizing a system approach, Freightliner Custom Chassis Corporation and Hendrickson worked together to optimize the SOFTEK system for motorhome chassis applications to deliver enhanced ride, stability and handling characteristics while reducing weight and maintenance.



## Proven Durability



- Tested and proven in heavy-duty applications
- **STEERTEK NXT Axle** — The box-shaped cross section resists horizontal, vertical and twisting forces more effectively than traditional I-beam axles. Continuous beam architecture minimizes stress points for added durability.
- **Enhanced clamp group** — innovative design distributes pressure around entire axle section for a secure, reliable axle connection

## Reduced Maintenance

- **Spring and rear shackle bushings** — heavy-duty design for durability and maintenance-free operation
- **Two-piece knuckle assembly** — allows for easy disassembly of knuckle without removing kingpin



Two-piece knuckle

## Weight Savings

The SOFTEK suspension, combined with Hendrickson's STEERTEK NXT formed and robotically welded axle, weighs less than traditional forged axle and steel spring designs.

## Enhanced Ride and Handling

- **Heavy-duty parabolic leaf spring** — optimized two-leaf spring design and premium shocks result in an outstanding ride
- **Jounce bumper** — integrated design enhances a smooth and comfortable ride
- **Optimized steering system performance** — delivers an industry leading wheel cut of up to 55 degrees resulting in a tighter turning radius and outstanding maneuverability



Optimized steering system —  
55-degree wheel cut

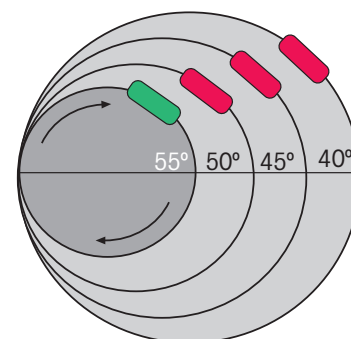

● Freightliner Custom Chassis

● Competitive Chassis

\* Not to scale

[www.hendrickson-intl.com](http://www.hendrickson-intl.com)



Truck Commercial Vehicle Systems 630.910.2800  
800 South Frontage Road Fax 630.910.2899  
Woodridge, IL 60517-4904 USA 1-855-755-5968



**Driven By You**

Freightliner Custom Chassis Corporation 864.487.1700  
552 Hyatt St. Fax 864.487.6400  
Gaffney, SC 29341