

# **TECHNICAL PROCEDURE**

## **TRAILER SUSPENSION SYSTEMS**

**SUBJECT:** Alignment Procedures

**LIT NO:** L579

**DATE:** April 2020

**REVISION:** H

---

### **TABLE OF CONTENTS**

<b>Important Safety Notices</b> .....	<b>2</b>
<b>Conventions Applied in This Document</b> .....	<b>2</b>
Explanation of Signal Words .....	2
Hyperlinks .....	2
Contacting Hendrickson.....	2
Relative Literature .....	3
Other relative literature may include:.....	3
Preparing Trailer for Maintenance Service .....	3
Tools And Equipment.....	4
TORX® Sockets .....	4
<b>Pivot Connection - Frame Bracket</b> .....	<b>5</b>
Pivot Connection - Welded Collar .....	6
Pivot Connection - QUIK-ALIGN® .....	6
<b>Pivot Connection - Y-Beam</b> .....	<b>7</b>
<b>Alignment Background</b> .....	<b>8</b>
<b>Alignment Preparations</b> .....	<b>10</b>
<b>Axle Alignment</b> .....	<b>12</b>
Kingpin to Front Axle Alignment Check .....	12
Axle-Axle Alignment Check.....	15
<b>Axle Alignment Adjustment</b> .....	<b>16</b>
QUIK-ALIGN® Axle Adjustment .....	16
Welded Collar Axle Adjustment .....	19
<b>CONNEX ST Axle Alignment</b> .....	<b>21</b>
CONNEX ST Alignment Summary.....	21
Locking the Self-Steer Axle.....	22
Check and Adjust Toe.....	23
<b>Pivot Connection Hardware Troubleshooting</b> .....	<b>25</b>
QUIK-ALIGN® .....	26
<b>Appendix A: Axle Target Value Sample Calculation</b> .....	<b>28</b>

## IMPORTANT SAFETY NOTICES

Hendrickson literature number **T12007** *Technical Procedure General Safety Precautions and Information*, available at [www.Hendrickson-intl.com/TrailerLit](http://www.Hendrickson-intl.com/TrailerLit), includes important preparation, precautionary and safety information pertaining to the procedures included in this document.

To help prevent personal injury and equipment damage; warnings, cautions and other relative statements included in Hendrickson literature number **T12007** are to be read carefully and applied during the performance of the procedures included in this document.

Improper maintenance, service or repair can cause damage to the vehicle and other property, personal injury, unsafe operating conditions and potentially void the manufacturer's warranty.

## CONVENTIONS APPLIED IN THIS DOCUMENT

Various techniques are used in this document to convey important information, express safety issues, provide methods for [CONTACTING HENDRICKSON](#) and how to identify and apply [HYPERLINKS](#).

## EXPLANATION OF SIGNAL WORDS

Hazard signal words (such as DANGER, WARNING or CAUTION) appear in various locations throughout this publication. Information accented by one of these signal words must be observed at all times. Additional notes are utilized to emphasize areas of procedural importance and provide suggestions for ease of repair. The following definitions comply with [ANSI Z535.6](#) and indicate the use of safety signal words as they appear throughout the publication.

### **DANGER**

Indicates a hazardous situation that, if not avoided, will result in death or serious injury.

### **WARNING**

Indicates a hazardous situation that, if not avoided, could result in death or serious injury.

### **CAUTION**

Indicates a hazardous situation that, if not avoided, could result in minor or moderate injury.

### **NOTICE**

Indicates information considered important, but not hazard-related (e.g. messages relating to property damage).

**IMPORTANT:** An operating procedure, practice or condition that is essential to emphasize.



**Safety Alert Symbol** used to indicate a condition exists that, if not avoided, may result in personal injury or harm to individuals. It must be applied to DANGER, WARNING and CAUTION statements, which emphasize severity.

## HYPERLINKS

Hyperlinks are identified by a dark grey line under the linked text. Internal links allow the reader to jump to a heading, step or page in this document. External links open the website or document referenced. While viewing electronically, activate the hyperlink by clicking on the underlined text.

## CONTACTING HENDRICKSON

Contact Hendrickson Trailer Technical Services for technical assistance as needed. To do so, several options are available. Technical Services must be contacted before performing any warranty related service.

**NOTE: DO NOT** service a suspension or any component that is under warranty without first contacting Hendrickson Technical Services.

Prior to contacting Technical Services, it is best to have the following information about the vehicle and Hendrickson suspension available (all that apply):

- **Hendrickson suspension** information, (refer to [L977 Suspension and Axle Identification](#)) –
  - Suspension model number
  - Suspension serial number
  - Approximate number of suspension miles
- **Trailer information** (located on VIN plate) -
  - Type (van, reefer, flat bed, etc...)
  - Manufacturer
  - VIN (vehicle identification number)
  - In-service date<sup>1</sup>
  - Fleet/owner name
  - Unit #

<sup>1</sup> If the in-service date is unknown or not available, the vehicle date of manufacture will be substituted.



- **Failure information**
  - Description of the system problem, the part number and/or the part description of the reported non-functioning part.
  - **Date of failure.**
  - Where applicable, **location of problem** on suspension / trailer (e.g., road side, front axle, rear axle, curb side rear, etc.).
- **Digital photos** of suspension and damaged areas.
- **Special application** approval documentation (if applicable).

## PHONE

Contact **Hendrickson Trailer Technical Services** directly in the United States and Canada+ at **866-RIDEAIR (743-3247)**. From the menu, select:

- **Technical Services/Warranty** for technical information.
- Other selections include:
  - **Aftermarket Sales** for replacement parts information and ordering.
  - **Original Equipment Sales** for parts inquiries and ordering for trailer manufacturers.

## EMAIL

[HTTS@Hendrickson-intl.com](mailto:HTTS@Hendrickson-intl.com)

Contact Hendrickson for additional details regarding specifications, applications, capacities, and operation, service and maintenance instructions.

All applications must comply with applicable Hendrickson specifications and must be approved by the respective vehicle manufacturer with the vehicle in its original, as-built configuration.

## RELATIVE LITERATURE

If you suspect your version of this or any other Hendrickson manual is not “up-to-date”, the most current version is free online at:

[www.Hendrickson-intl.com/TrailerLit](http://www.Hendrickson-intl.com/TrailerLit)

Available Hendrickson documentation can be viewed or downloaded from this site.

All Hendrickson online documentation is in PDF format that requires PDF reader software to open. A free application is downloadable from Adobe at <http://get.adobe.com/reader/>.

Other relative literature may include:

NAME	DESCRIPTION
<a href="#">B31</a>	<i>Torque Specifications</i>
<a href="#">L427</a>	<i>Bushing Replacement Procedure</i>
<a href="#">L459</a>	<i>Checking Trailer Ride Height</i>
<a href="#">L577</a>	<i>HT™ Series Suspension Installation Procedures</i>
<a href="#">L583</a>	<i>Comprehensive Warranty Statement</i>
<a href="#">L785</a>	<i>Pre-aligned VANTRAAX® Warranty Update</i>
<a href="#">L874</a>	<i>Pre-aligned VANTRAAX Alignment Verification Procedure</i>
<a href="#">L926</a>	<i>Factory-torqued Curbside Pivot Connection</i>
<a href="#">L1072</a>	<i>QUIK-ALIGN® Pivot Connection Fastener Information</i>
<a href="#">T62001</a>	<i>Self-steer Axle Installation and Maintenance Procedures</i>

Table 1: Relative Literature

Hendrickson reserves the right to make changes and improvements to its products and publications at any time. Consult the Hendrickson website

[www.Hendrickson-intl.com/TrailerLit](http://www.Hendrickson-intl.com/TrailerLit)

for the latest version of this manual.

## PREPARING TRAILER FOR MAINTENANCE SERVICE

Information for trailer preparation, safety and precautionary statements, refer to Hendrickson literature number [T12007](#), available at [www.Hendrickson-intl.com/TrailerLit](http://www.Hendrickson-intl.com/TrailerLit).

**NOTE: DO NOT** service a suspension or any components that is under warranty without first contacting Hendrickson Technical Services. Refer to [CONTACTING HENDRICKSON](#) for details.

**⚠WARNING** **DO NOT** work under a trailer supported only by jacks. Jacks can slip or fall over, resulting in serious personal injury. Always use safety stands to support a raised trailer.

## TOOLS AND EQUIPMENT

The following tools may be required during the performance of applicable maintenance procedures:

- For KINGPIN TO FRONT AXLE ALIGNMENT CHECK on page 12:
  - 50-foot (minimum) steel tape measure with  $\frac{1}{32}$  inch increments .
  - Tape tensioning (spring) device required for measurements with tape measure. Consisting of:
    - » Fish (or engineering) scale, spring-loaded
    - » Clamp - grips tape measure for use with fish scale.
    - » String - used to fasten the clamp to the fish scale.
  - Kingpin adapter or kingpin extender (pogo stick).
  - Level - used to plumb the kingpin extender.
  - Wheel-end (or spindle) extenders, 2 minimum.
- For AXLE-AXLE ALIGNMENT CHECK on page 15: Trammel bar (preferred) or 12-foot (minimum) steel tape measure with  $\frac{1}{32}$  inch increments .
- Impact wrench with a minimum torque capability of 600 ft. lbs. (813 Nm).
- For QUIK-ALIGN® Pivot Bolt Kits:
  - E20 TORX® socket; 1 inch drive recommended.
  - $1\frac{7}{16}$  inch box end wrench.
  - $\frac{1}{2}$  inch drive breaker bar or ratchet.
- For all HT® Series with welded collar pivot bolt kits:
  - $1\frac{11}{16}$  inch shallow impact socket.
  - $1\frac{11}{16}$  inch box end wrench.
- Tire changing equipment (as needed).
- Tire pressure gauge.
- Rubber mallet.
- $\frac{3}{8}$  inch pin punch (for Hendrickson self-steer axle).

**IMPORTANT:** A calibrated torque wrench must be used to tighten fasteners to specified values. Refer to Hendrickson literature number B31 for torque specifications.

## TORX® SOCKETS

Hendrickson offers four TORX sockets (Table 2) that may be used on the shear-type bolt during alignment. E20 and E22 TORX sockets are also available from other vendors.

TORX® SOCKET SIZE	DRIVE SIZE	PIVOT CONNECTION	COMMENTS
<b>E20</b> (part # <b>A-24303</b> )	$\frac{3}{4}$ "	QUIK-ALIGN®	For occasional use (not recommended for high-volume trailer production environments)
<b>E20</b> (part # <b>A-24536</b> )	1"	QUIK-ALIGN	For medium-duty use (dealers, repair facilities, etc.)
<b>E20 with sleeve</b> (part # <b>A-25119</b> )	1"	QUIK-ALIGN	For high-volume trailer production environments or manufacturing facilities. The sleeve provides greater operator control.

Table 2: Hendrickson E20 TORX socket summary

**NOTICE: Hendrickson does not recommend the  $\frac{3}{4}$  inch drive socket for use in high volume trailer production environments. The  $\frac{3}{4}$  inch drive socket can back away from full TORX head engagement during the shearing process and strip the TORX-head splines. When damage occurs to the TORX-head splines, the proper torque and clamp load may not be achieved.**

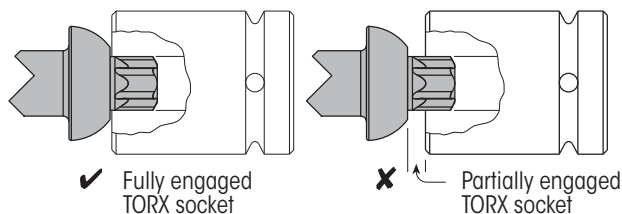

Figure 1: Socket engagement

To avoid damaging the shear bolt's TORX-head (regardless of the drive socket being used), the drive socket must fully engage the TORX-head (Figure 1).

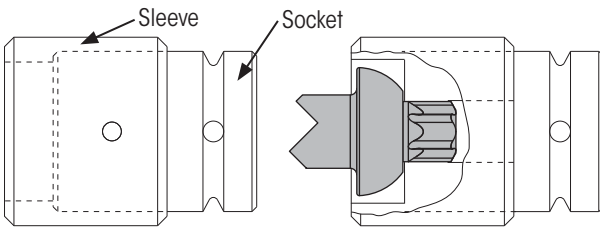

Figure 2: 1 inch drive E20 TORX socket with sleeve (A-25119)

For QUIK-ALIGN style pivot connections in high volume trailer production and service facilities, Hendrickson recommends the one-inch drive E20 TORX socket (Table 2), with sleeve (Figure 2). The sleeve helps support the tool by riding over the entire head of the shear bolt. It also provides greater operator control at the moment of shear by preventing the heavy tool from veering. The operator can rest the tool on the bolt during the entire operation resulting in greater control of socket-to-bolt engagement, reduced fatigue and consistently torqued pivot connections.

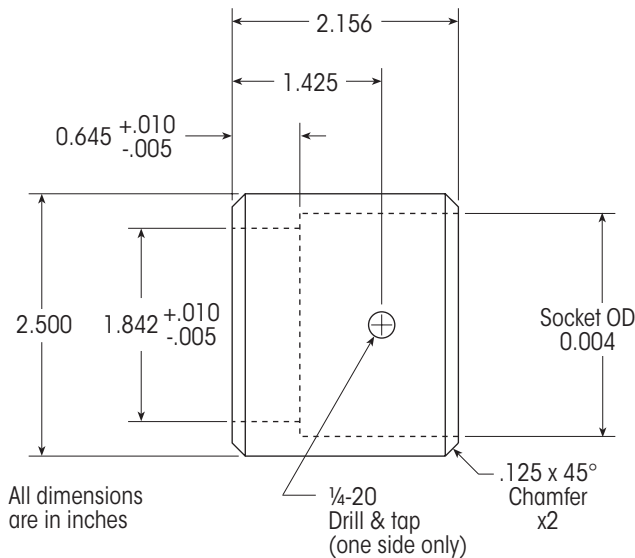

Figure 3: Sleeve dimensions

### FABRICATION NOTES:

1. Sleeve undersized by .004; shrink fit socket into sleeve OD.
2. Drill and tap assembly for 1/4-20 x .25 (oval point) standard hex socket set screw.
3. Material:  $\varnothing 2.500$  6150 H.R.S.
4. Heat treatment (sleeve):
  - a. Oil drenched: 1550° F (538° C)
  - b. Tempered: 1000° F (843° C)

If you already own the one-inch drive E20 TORX socket without the sleeve (Table 2) and wish to add a sleeve to it, dimensions are included in Figure 3. A local fabricating shop can make and assemble the sleeve using this information.

## PIVOT CONNECTION - FRAME BRACKET

Hendrickson suspensions are equipped with either QUIK-ALIGN® or welded-collar style pivot connections. The following information is for suspensions with a frame bracket.

**⚠ CAUTION: DO NOT apply anti-seize compound or additional lubricant to pivot connection hardware. A dry lubricant coating has been applied to the threads of the pivot connection bolt and nut. Do not allow undercoating, paint, surface coatings, or any other commonly used compounds to contact the threads of the pivot connection fasteners. These compounds can act like a lubricant, reducing the friction between the threads of the nut and bolt. This can lead to overtightened fasteners, unpredictable pivot connection clamp loads and unreliable axle alignments. Threads should be clean, dry and free of contamination, as supplied by Hendrickson.**

**⚠ CAUTION: DO NOT apply undercoating, paint or other surface coating to the suspension and frame brackets until after completing the alignment. These products will act as a lubricant to contaminate and compromise the fastener clamp load, resulting in a loose connection or worse.**

If coating prior to assembly, areas where alignment collars and bushing inner metal contact the frame bracket (suspension beam for Y-beams) must be masked as shown in Figure 4.

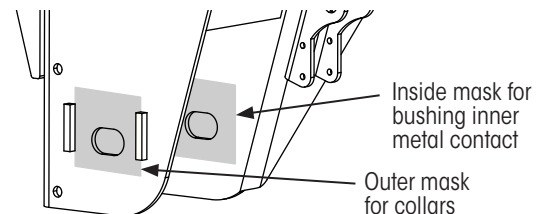

Figure 4: Paint mask areas (example for QUIK-ALIGN®)

With frame brackets or Y-beams, the procedures for checking and adjusting trailer axle alignment is the same. However, applicable pivot connection hardware kits must be used. Refer to applicable parts catalogs listed at [www.hendrickson-intl.com](http://www.hendrickson-intl.com).

For Y-beam suspensions, refer to PIVOT CONNECTION - Y-BEAM on page 7.

## PIVOT CONNECTION - WELDED COLLAR

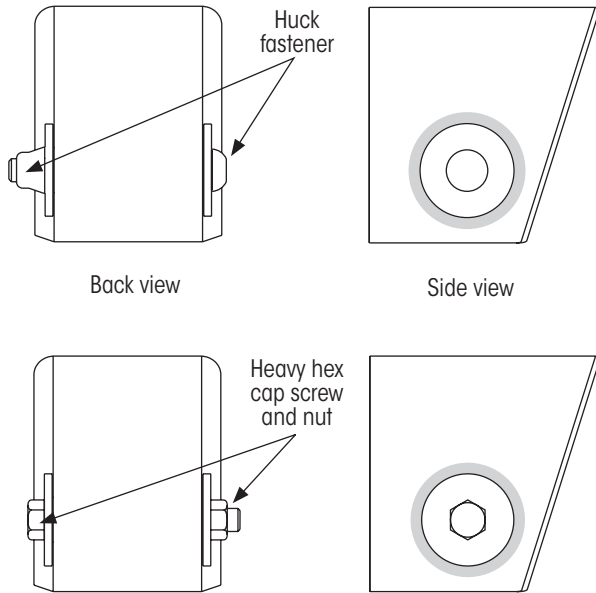

Figure 5: Welded Collar pivot connection

The welded collar style pivot connection is clamped together by either a Huck® Fastener or a 1 1/8 inch heavy hex cap screw and nut (Figure 5). After the alignment is completed, the entire circumference of both inboard and outboard collars is welded to the frame bracket. The nut is welded to the 1 1/8 inch heavy hex cap screw (if used instead of the Huck fastener).

To realign this style of pivot connection, the collar welds must be removed so the pivot joint can be repositioned.

## PIVOT CONNECTION - QUIK-ALIGN®

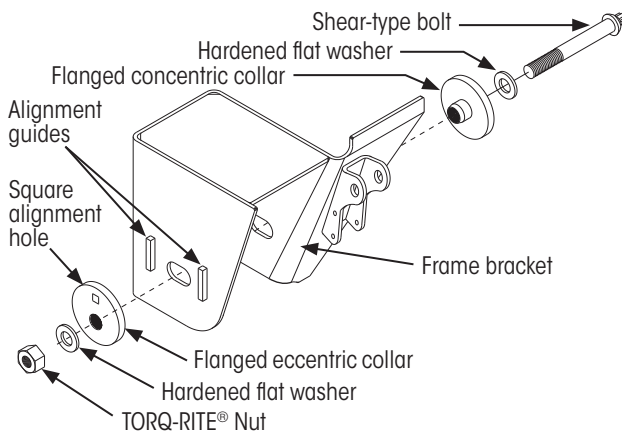

Figure 6: Frame bracket QUIK-ALIGN pivot connection

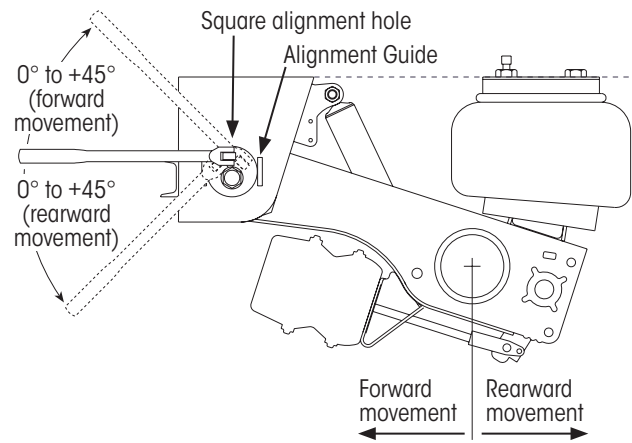

Figure 7: Rotating QUIK-ALIGN flanged eccentric collar

The QUIK-ALIGN style pivot connection uses two flanged collars inserted into slots on each side of the frame bracket (Figure 6). The eccentric collar on the outboard side of the frame bracket is used to adjust the position of the axle during an alignment. The alignment guides on the side of the frame bracket limit the eccentric collar to rotational movement in the frame bracket slot. Rotating the eccentric collar clockwise causes the axle to move forward. Rotating the eccentric collar counterclockwise causes the axle to move rearward (Figure 7). The maximum range of adjustment is  $\pm 45$  degrees from the 12 o'clock position.

Along with hardened flat washers, a shear-type bolt and a TORQ-RITE® Nut are also part of the QUIK-ALIGN style pivot connection. Use of this shear-type bolt and TORQ-RITE nut with an E20 TORX® socket ensures proper clamping force without the use of a torque wrench.



## PIVOT CONNECTION - Y-BEAM

HT™ Series Y-beam suspensions differ from other suspension beams because they do not use a frame bracket. The fork or “Y” of the beam connects directly to the trailer frame using the bushing tube sleeve (Figure 8 and Figure 9, item 1).

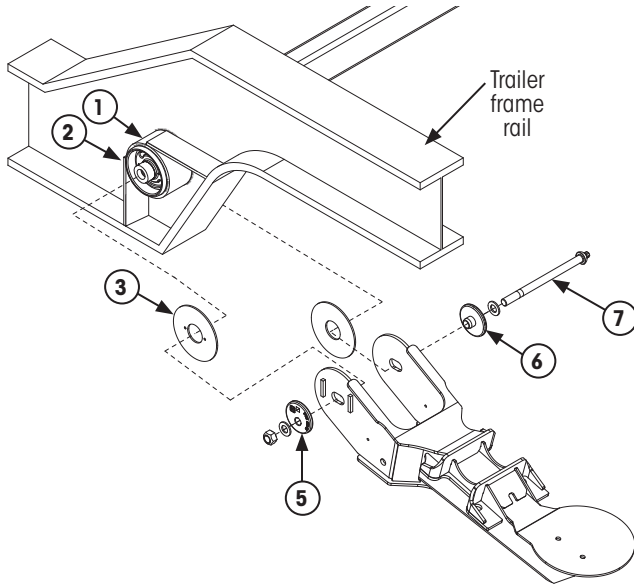

Figure 8: QUIK-ALIGN® pivot connection hardware

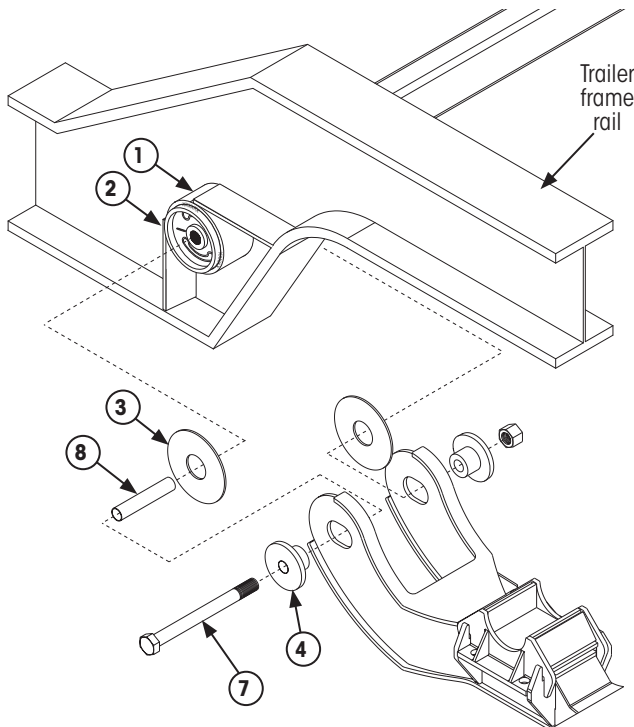

Figure 9: Welded collar pivot connection hardware

ITEM	DESCRIPTION	WELDED	QUIK-ALIGN
1	Bushing tube sleeve	4	4
2	Bushing assembly	4	4
3	Bushing tube spacers (2 ea)	4	4
4	Welded alignment collars (2 ea)	4	
5	Eccentric alignment collar		4
6	Concentric alignment collar		4
7	Pivot bolt and nut	4	4
8	Delrin® liner	4	

Table 3: Pivot connection hardware list

With frame brackets or Y-beams, the procedures for checking and adjusting trailer axle alignment is the same. However, applicable pivot connection hardware kits must be used. Refer to applicable parts catalogs listed at [www.hendrickson-intl.com](http://www.hendrickson-intl.com).

**ALIGNMENT BACKGROUND**

Properly aligned trailer axles optimize fuel economy, driveability and help prevent excessive tire wear.

A perfect alignment scenario has all trailer wheels parallel to one another and perpendicular to the centerline of the trailer. However due to uncontrollable factors, this perfect scenario is often an unreasonable expectation. A more likely alignment scenario has the trailer wheels parallel within a very small tolerance range to one another and perpendicular within a very small tolerance range to the centerline of the trailer.

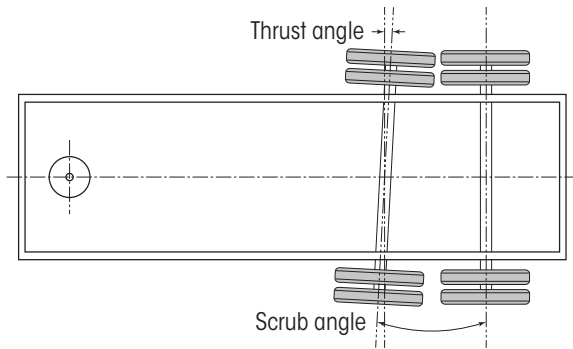

Figure 10: Tandem trailer axle-axle angles

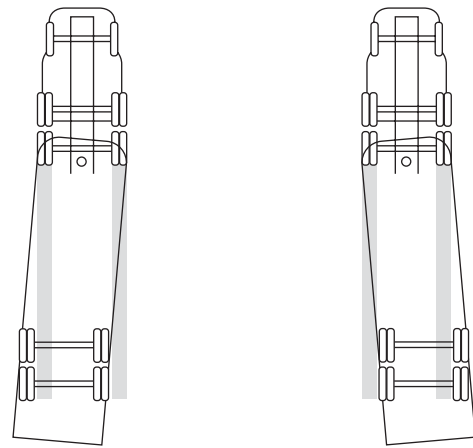

Figure 11: Examples of dog tracking

There are two important trailer axle angles that must be kept within recommended tolerance ranges: **thrust angle** and **scrub angle** (Figure 10). These angles, when out of tolerance, can lead to increased rolling resistance, excessive tire wear and can contribute to trailer "dog tracking". Dog tracking (Figure 11) is a condition where the trailer does not follow or track directly behind the truck as the vehicle is being operated in a straight line and is influenced by body rail alignment, kingpin location, axle side-to-side location, etc. The procedures presented in this publication detail how to check and, if necessary, bring these angles within the recommended tolerance range.

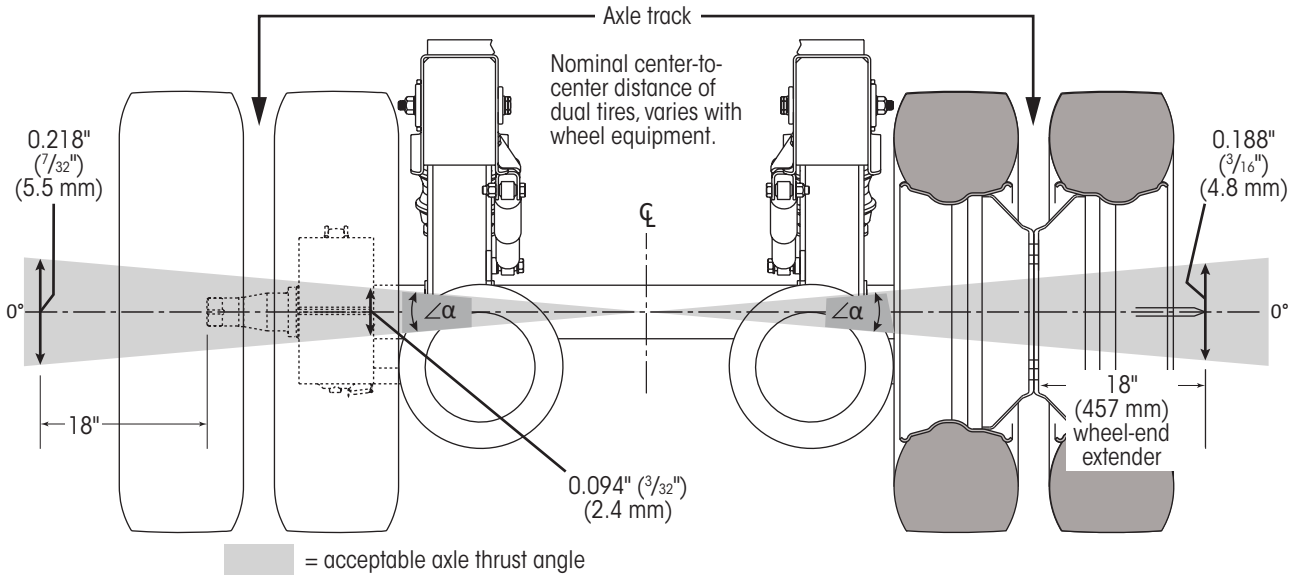

Figure 12: Thrust angle geometry example



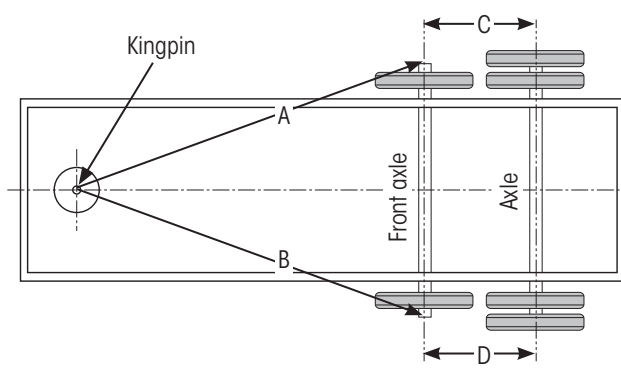

Figure 13: Measurements to check axle-axle alignment

The front (non-steer) axle is used as a starting point to measure thrust angle. First, the measurement target value (or tolerance range) is determined. Then, the distance from the kingpin (used as the trailer centerline) to matching points on each end of the front (non-steer) axle is measured (distances “A” and “B” in Figure 13). The difference between these two measurements is then compared to the measurement target value to determine the axle thrust angle. If the difference between the “A” and “B” measurements is larger than the target value, the axle must be adjusted to achieve an acceptable axle thrust angle. If the difference between the “A” and “B” measurements is smaller than or equal to the target value, axle thrust angle is within the tolerance range and no adjustment is necessary. The remaining axles are then measured with respect to the front axle and adjusted, if necessary, to an acceptable scrub angle.

Even though distances are being measured using measurement points on the ends of the axle, it is the axle thrust angle that is important. As shown in Figure 12, the acceptable axle thrust angle remains constant over the length of the axle. However, the measurement target value that coincides with the acceptable axle thrust angle varies over the length of the axle. Because of a simple geometrical relationship, the measurement target value gets larger as you move farther away from the center of the axle.

**EXAMPLE A:** Kingpin-front axle measurement with wheel-end extenders:

Measuring from the kingpin to a point 18 inches beyond the end of the spindle might produce a measurement target value of  $\pm 0.218$  ( $7/32$ ) inches (Figure 12). But a measurement from the kingpin to the brake drum might only produce a measurement target value of  $\pm 0.094$  ( $3/32$ ) inches. Both of these measurements are within the acceptable axle thrust angle, but one is more than two times larger

than the other. This is because one measurement is taken at a point much farther away from the center of the axle than the other measurement.

The typical trailer industry alignment specification for thrust angle is  $\pm 0.1$  degrees when measured from the kingpin to the axle track of a 71.5 inch track axle (distances “A” and “B” in Figure 13). Hendrickson suspensions are no different. However, there are two additional clarifications to this specification that must be addressed. The first one deals with axle track (Figure 12). Using the value for axle track simplifies the axle thrust angle calculation, but it is impractical to use axle track for a measurement. Not only does the outer tire/wheel assembly have to come off to even attempt the measurement, but where specifically on the spindle do you measure to? What point on the spindle defines axle track? A more practical approach is to use wheel-end extenders to provide a more accurate and consistent measurement point (more wheel-end extender information is presented later in this document).

The second clarification deals with measurement limitation. The  $\pm 0.1$  degrees of thrust angle is difficult to achieve because of measurement limitations. No currently existing alignment measurement method can consistently provide an alignment within this  $\pm 0.1$  degree tolerance. The reason for this is measurement error.

MEASUREMENT METHOD	PRECISION/TOLERANCE RATIO ( $\pm 0.1^\circ$ )	PRECISION/TOLERANCE RATIO ( $\pm 0.2^\circ$ )
Tape measure to rim	330%	165%
Laser devices <sup>1</sup>	309%	155%
1/16" graduated tape measure to wheel-end extenders	207%	104%
1/32" graduated tape measure to wheel-end extenders	148%	74%
Extensometer	64%	32%

<sup>1</sup> Per SAE technical paper 933046

Table 4: Measurement method and associated accuracy

All measurement devices and procedures (Table 4) have variations that affect their accuracy. A study typically performed to identify measurement device or procedure accuracy is a gauge repeatability and reproducibility study. It evaluates how well the measurement device or procedure can perform with respect to specifications. The result of such a study is a factor called “precision

to tolerance ratio". This ratio expresses the percent of the tolerance used up by measurement error.

**EXAMPLE B:** Measurement error:

Say you have a measurement with a tolerance of  $\pm 0.125$  ( $1/8$ ) inches. Say also that the result of a gauge repeatability and reproducibility study revealed a precision to tolerance ratio of 75 percent. This means that  $\pm 0.0938$  ( $3/32$ ) inches (or 75 percent) of the  $\pm 1/8$  inch tolerance could be attributed to measurement error.

As summarized by [Table 4](#), the measurement error introduced by current alignment measurement methods (except extensometer devices) is greater than the  $\pm 0.1$  degree industry specification.

With the two previously described clarifications in mind, Hendrickson continues to recommend using the  $\pm 0.1$  degree thrust angle alignment specification for initial alignments, realizing that, due to measurement error, the actual thrust angle may be in the  $\pm 0.2$  degree range. The  $\pm 0.2$  degree range complies with most tire manufacturers' recommendations for an allowable trailer axle thrust angle. Hendrickson also recommends using a steel tape measure with  $1/32$  inch graduations, a tape tensioning device and wheel-end extenders to allow for greater measurement accuracy. Subsequent alignment verification measurements should use the  $\pm 0.2$  degree thrust angle range recommended by most tire manufacturers.

## ALIGNMENT PREPARATIONS

The primary purpose for following the procedures in this document is to ensure all axles are parallel to one another and perpendicular to the trailer frame. Pivot connection positioning is not the only factor that can influence the parallelism between axles. A thorough inspection of the trailer should be performed prior to alignment to determine tire condition and if damage or worn components exist (see Hendrickson literature number [L578 Preventive Maintenance Guide](#)). The trailer should be set as close as possible to normal driving conditions.

### SELECT THE ALIGNMENT AREA

The alignment should be performed on a flat, level, debris-free surface.

### PERFORM TIRE INSPECTION

All of the tires on each axle must be matched to within  $1/4$  inch in diameter and  $3/4$  inch in circumference.

The tires must also be at the manufacturer's recommended load bearing pressure when checking or performing an axle alignment. Inflate or deflate the tires to match this recommended pressure.

Also make sure that the same tires and rims are mounted on each axle.

### SET SUSPENSION RIDE HEIGHT

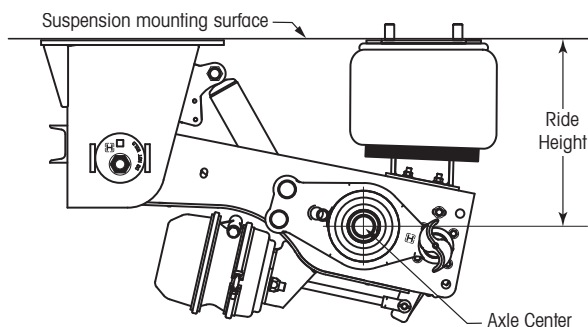

Figure 14: Ride height defined

The suspension must be at its designed ride height when checking or performing an axle alignment. A suspension's designed ride height (Figure 14 and listed on the original suspension ID tag) is defined as the distance from the suspension mounting surface (the bottom of the trailer frame or slider box) to the center of the axle, with air applied. For complete instructions on determining and setting ride height, refer to Hendrickson literature number [L459 Checking Trailer Ride Height](#).

## PROPERLY POSITION THE TRAILER

Trailer positioning is important during alignment. The trailer suspension must be in a “relaxed” state without any pre-load applied to the TRI-FUNCTIONAL® Bushings.

**IMPORTANT:** A pre-loaded bushing will complicate the axle alignment process by providing inaccurate measurement data. Also, a seemingly aligned axle that contains an unknowingly compressed bushing may cause tracking problems and/or premature tire wear. To avoid these conditions, perform the proper trailer positioning procedure as follows.

**Read entire procedure before performing.**

1. **Position** trailer for alignment.
2. With trailer still coupled to the tractor, **adjust** trailer landing legs so there is adequate ground clearance.
3. **Sliders only:**
  - A. **Move** slider to rear-most position of the trailer.
  - B. Make sure the slider locking **pins are fully extended** through the body rail holes.
4. **Position** the trailer so it is as close as possible to its forward operational state by doing the appropriate step:
  - A. **If drive-through** maintenance bay or on open paved surface, **pull** trailer straight forward for a minimum of ten feet.
  - B. **If no drive-through**, **back** trailer into a maintenance bay as straight as possible, then gently pull it forward ten feet or more.
5. Ease the trailer to a stop using only the tractor brakes, thus relieving bushing pre-load.
 

**IMPORTANT:** Keep trailer parking brakes disengaged to allow wheel rotation while positioning axle fore and aft.

**NOTE:** For sliders, this also forces slider locking pins to rear of the body rail holes, removing locking pin slack and relieving bushing pre-load.
6. **Lower** trailer landing legs so they contact the ground. Uncouple trailer from the tractor and apply shop air to trailer emergency glad hand to release parking brakes.

## SET DESIGNED KINGPIN HEIGHT

Set the front of the trailer to its designed kingpin height:

1. **Determine** what the designed kingpin height should be. Check the trailer ID tag on the trailer front bulkhead or contact the trailer manufacturer for the designed kingpin height.



Figure 15: Measuring actual kingpin height

2. Using a tape measure, **determine** the current trailer kingpin height by measuring from the ground to the kingpin mounting plate (Figure 15).
3. **Adjust** the landing legs to place the trailer at the designed kingpin height.
4. **Verify** the kingpin height by measuring from the ground to the kingpin mounting plate.

## AXLE ALIGNMENT

If necessary, refer to [ALIGNMENT BACKGROUND](#) on page 8 and [ALIGNMENT PREPARATIONS](#) on page 10 before performing these axle alignment procedures.

### KINGPIN TO FRONT AXLE ALIGNMENT CHECK

This would be the **thrust angle alignment** performed on the front (non-steer) axle. If a lift axle, ensure axle is in the down position.

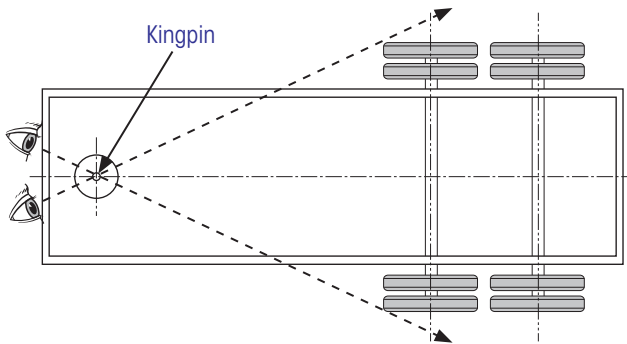

Figure 16: Checking for measurement obstructions

1. From a position at the front of the trailer (Figure 16), **sight** along a line under the trailer from the kingpin to each end of the front axle.

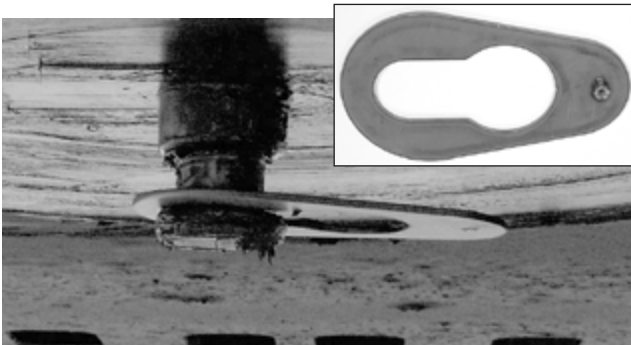

Figure 17: Kingpin adapter

- A. If this sightline is free from under-trailer obstructions that would interfere with a measurement (i.e., landing legs, trailer frame, tool boxes, etc.), then the kingpin adapter (Figure 17) can be used to make the measurement in [Step 5](#).

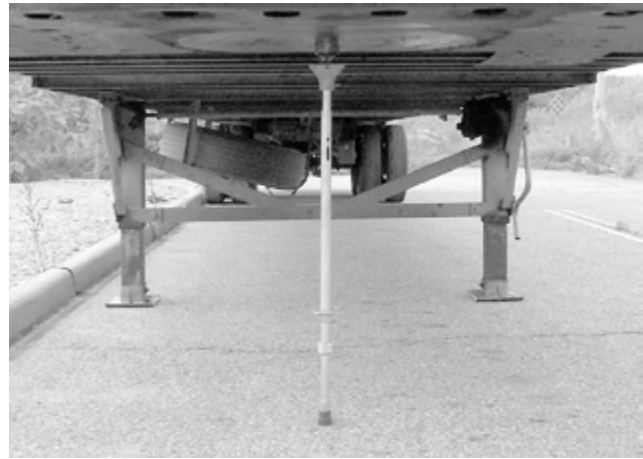

Figure 18: Kingpin extender

- B. If this sightline is obstructed, then the kingpin extender or pogo stick (Figure 18) must be used to lower the connection for the measurement in [Step 5](#).

**NOTE:** Follow manufacturer's instructions to install and align the kingpin extender. The extender typically includes a leveling bubble to ensure vertical alignment.

2. **Place** kingpin adapter (Figure 17) or kingpin extender (Figure 18) onto the kingpin.



Figure 19: Installed wheel-end extender

3. Following the manufacturer's recommended instructions, **install** wheel-end extenders on each end of the front axle (Figure 19).

**NOTE:** A wide range of wheel-end extenders are available from various companies, ranging from simple fixtures to complex devices. Wheel-end extenders are designed to ease alignment by eliminating the need to remove the outer wheel when checking or aligning axles. Once in place, wheel-end extenders position axle reference points far enough outside the trailer to allow the measuring tape to clear tires when measuring "A" and "B" dimensions from the kingpin. Some wheel-end extenders require contact with the spindle plug through the hub cap oil fill hole. Others offer a more universal mount, fitting over the entire hub. Select wheel-end extenders that work best with your style of hubs.

**IMPORTANT:** Make sure the wheel-end extenders are a matched pair and are properly installed. Failure to properly install a matched pair of wheel-end extenders will significantly reduce the accuracy of the alignment measurement.

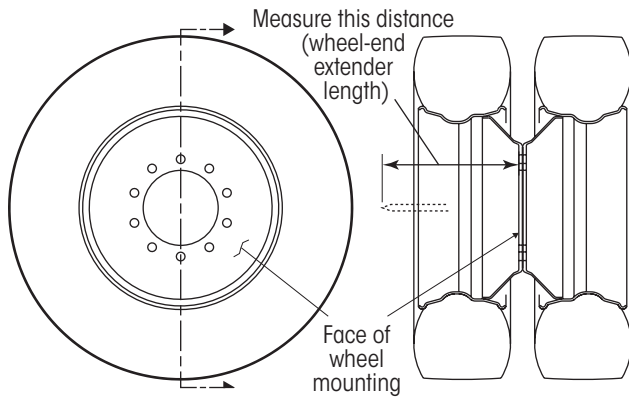

Figure 20: Measuring wheel-end extender length

4. **Determine and record** the front axle target value:
  - A. **Measure** the length of one wheel-end extender. **Measure** from the face of the wheel mounting to the tip of the wheel-end extender (Figure 20).
  - B. **Read** the axle target value from Table 5.

FRONT AXLE TARGET VALUES <sup>1,2</sup>											
Track Length:		71.5									
Kingpin-to-Axle <sup>2</sup> :		48	44	40	36	32	28	24	20	16	12
Wheel Extender Length	12	5/32									
	13										
	14										
	15	3/16									
	16										
	17										
	18	7/32									
	19										
	20										
	21	5/32									
	22										
23											
24											
Track Length:		77.5									
Kingpin-to-Axle <sup>2</sup> :		48	44	40	36	32	28	24	20	16	12
Wheel Extender Length	12	5/32									
	13										
	14										
	15	3/16									
	16										
	17										
	18	7/32									
	19										
	20										
	21	5/32									
	22										
23											
24											
Track Length:		83.5									
Kingpin-to-Axle <sup>2</sup> :		48	44	40	36	32	28	24	20	16	12
Wheel Extender Length	12	3/16									
	13										
	14										
	15	7/32									
	16										
	17										
	18	5/32									
	19										
	20										
	21	3/16									
	22										
23											
24											

<sup>1</sup> The kingpin-front axle (or thrust angle) target values presented in this table have been pre-calculated for your convenience. To see the steps involved in this process and an example of front (non-steer) axle target value calculation, refer to APPENDIX A: AXLE TARGET VALUE SAMPLE CALCULATION on page 28.

<sup>2</sup> Kingpin-to-axle distance values are in feet. All others are in inches.

Table 5: Kingpin-front axle target values



**EXAMPLE C:** Kingpin-front axle target value:

Suppose the measured length of your wheel-end extender is 18 inches and your trailer has a 77.5 inch axle track. **First**, find the 18 inch row in the 77.5 inch section of the table. **Then**, find the column for a 40-foot kingpin-to-axle distance and **read down** the column. The **value shown** where 18 inch wheel-end extender length and 40-foot kingpin-to-axle meet is  $\frac{3}{16}$  inch (See Figure 12), which is the front axle target value. This front axle target value will be required for a comparison in Step 6.

**NOTE:** Axle track can be read from the suspension model identification tag, found on the inside surface of the curbside beam (INTRAAX® suspensions) or on the roadside slider box side rail above the front frame bracket (VANTRAAX® and ULTRAAX-K® suspensions). For complete details on reading the Hendrickson suspension identification tag, refer to Hendrickson literature number L977 *Trailer Suspension System and Axle ID Guide*.



Figure 21: Using tape tension device (fish scale)

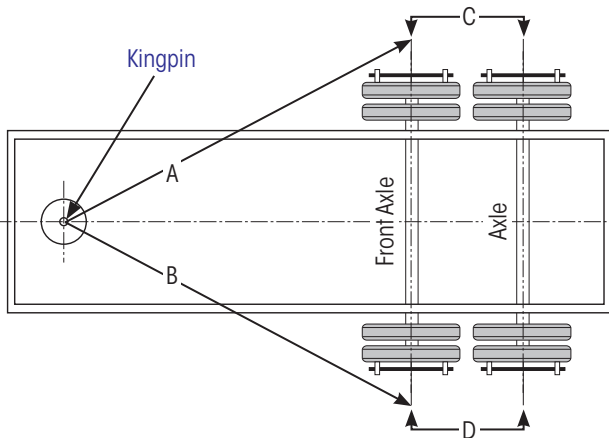

Figure 22: Axle alignment measurements



Figure 23: Measuring the "A" and "B" distances

5. **Hook** a steel measuring tape (50-foot minimum) to the kingpin adapter (or kingpin extender). **Holding** the measuring tape with the tape tensioning device (Figure 21), **measure** the distances "A" and "B" from the kingpin to the wheel-end extender pointer on each end of the front axle (Figure 22 and Figure 23).

**IMPORTANT:** The same pulling force applied to the measuring tape when measuring distance "A" must also be applied when measuring distance "B". When making the measurements, closely monitor the tensioning device (spring) scale to ensure the same pulling force is used in both measurements.

6. **Subtract** the smaller of the "A" and "B" measurements from the larger of the two, then compare this difference with the target value obtained in Step 4.
  - A. If the difference between the "A" and "B" measurements is **larger** than the target value, go to **AXLE ALIGNMENT ADJUSTMENT** on page 16 to correct the alignment.

**IMPORTANT:** If adjustment is required for the front non-steer axle, all other axles will likely require adjustment.

- B. If the difference between the "A" and "B" measurements is **smaller than or equal to** the target value, the axle is within specification and no alignment is necessary.



**EXAMPLE D:** Calculating front axle measured value:

Suppose distance "A" was measured to be  $420\frac{1}{8}$  inches and distance "B" was measured to be  $420\frac{11}{16}$  inches. Subtracting yields this difference:

$$420\frac{11}{16}'' - 420\frac{1}{8}'' = \frac{9}{16}''$$

When compared to the target value ( $\frac{3}{16}$  inches, read from the Table 5 in Step 4),  $\frac{9}{16}$  inches is larger. Therefore the axle must be adjusted to bring the "A" and "B" difference within the target value.

7. Perform AXLE-AXLE ALIGNMENT CHECK for all other axles.

### AXLE-AXLE ALIGNMENT CHECK

To be parallel to within the acceptable scrub angle range (Figure 22, C and D), axles must be aligned to the front non-steer axle checked in the previous procedure.

8. **Measure** distance between axle centers (Figure 22, C and D) for selected axle:

A. Method 1 - **Using trammel bar** (preferred):

- i. **Hold** trammel bar so points are positioned from axle center to axle center.
- ii. **Record** measured value for C.
- iii. **Repeat** for same axles on opposite end to measure and record D.

**NOTE:** The target value when using a trammel bar placed within the center dimples of the hubcaps is within  $\frac{1}{16}$  inch (0.08 degrees) for 71.5 or 77.5 inch axle track. However, if wheel extenders are used, refer to Table 6.

B. Method 2 - **Using tape measure:**

- i. **Following** the manufacturer's recommended instructions, **install** wheel-end extenders on each wheel end (Figure 19).

**NOTE:** If four wheel-end extenders are available (Figure 19), install a second pair on each axle to be measured for C and D, reference to front axle. Otherwise wheel-end extenders need to be removed and reinstalled to wheel ends on one side, then the other, to perform the measurements.

- ii. **Measure** wheel-end extender length from the face of the wheel mounting to the tip of the wheel-end extender (Figure 19 on page 12).

WHEEL-END EXTENDER LENGTH	AXLE TRACK	
	71.5"	77.5"
12"	$\frac{3}{32}''$	$\frac{3}{32}''$
13"	$\frac{3}{32}''$	$\frac{3}{32}''$
14"	$\frac{3}{32}''$	$\frac{3}{32}''$
15"	$\frac{3}{32}''$	$\frac{3}{32}''$
16"	$\frac{3}{32}''$	$\frac{3}{32}''$
17"	$\frac{3}{32}''$	$\frac{3}{32}''$
18"	$\frac{3}{32}''$	$\frac{3}{32}''$
19"	$\frac{3}{32}''$	$\frac{3}{32}''$
20"	$\frac{3}{32}''$	$\frac{3}{32}''$
21"	$\frac{3}{32}''$	$\frac{3}{32}''$
22"	$\frac{3}{32}''$	$\frac{3}{32}''$
23"	$\frac{3}{32}''$	$\frac{1}{8}''$
24"	$\frac{3}{32}''$	$\frac{1}{8}''$

<sup>1</sup> The scrub angle target values presented in this table have been pre-calculated for your convenience. To see the steps involved in this process and an example of axle target value calculation, refer to APPENDIX A: AXLE TARGET VALUE SAMPLE CALCULATION on page 28

Table 6: Scrub angle target values if using wheel-end extenders

- iii. **Read** the axle target value from Table 6<sup>1</sup>.
- iv. **Measure** the distances for "C" and "D" from the front non-steer axle center to the axle center (Figure 22 on page 14).

**IMPORTANT:** When using a tape measure, the tensioning (spring) device must also be used. The same pulling force applied to the tape measure when measuring distance "C" must also be applied when measuring distance "D". When making the measurements, closely monitor the tensioning device scale to ensure the same pulling force is used in both measurements.

9. **Subtract** the smaller of "C" and "D" (Figure 22) from the larger of the two measurements.

10. **Record** scrub angle value for axle being measured.

<sup>1</sup> **Example E** - Axle-axle target when using wheel-end extenders:

Suppose the measured length of your wheel-end extender is 18 inches and your trailer has a 77.5 inch axle track.

- A. **Find** the 18 inch **row** in Table 6.
- B. **Find** the **column** for 77.5 inch axle track and **read down** the column.

The value shown where 18 inch wheel-end extender length and 77.5 inch axle track meet is  $\pm\frac{3}{32}$  inch, which is the axle target value.

11. Compare the difference with the axle target value obtained in Step 8, method A or B.
- If the difference between the "C" and "D" measurements is **larger than** the target value, the axle must be adjusted to bring this difference within the target value. Go to AXLE ALIGNMENT ADJUSTMENT on page 16 to adjust pivot connection for scrub angle.
  - If the difference between the "C" and "D" measurements is **smaller than or equal to** the target value, the axle is within specification and no adjustments are required.

On trailers equipped with more than two axles, repeat this procedure to measure and, if necessary, adjust all other axles to the front axle (Figure 22, C and D) to prevent inaccuracies.

**IMPORTANT:** For self-steer axle-axle alignment, first refer to CONNEX ST AXLE ALIGNMENT on page 21.

## AXLE ALIGNMENT ADJUSTMENT

**⚠ CAUTION:** DO NOT apply undercoating, paint or other surface coating to the suspension and frame brackets until after completing the alignment. Mask as shown in Figure 4 on page 5.

### QUIK-ALIGN® AXLE ADJUSTMENT

If necessary, refer to PIVOT CONNECTION - QUIK-ALIGN® on page 6.

In June 2006, Hendrickson began factory-torquing curbside QUIK-ALIGN pivot connections on all VANTRAAX® slider suspension systems. "Factory-torquing" simply means the curbside pivot connection is aligned in the center of its adjustment range (Figure 7 on page 6) and tightened to the proper torque before the suspension leaves the Hendrickson facility. Therefore the curbside pivot connection on all VANTRAAX slider axles should not require any attention.

Alignment will be performed using the roadside pivot connection only. For more information, refer to Hendrickson literature number L926 Factory-torqued Curbside Pivot Connection.

If your suspension is a VANTRAAX factory-torqued model, perform the alignment using the roadside pivot connections in the following procedures. If needed, curbside pivot connection can be adjusted.

For all other models, neither roadside or curbside pivot connections are pre-torqued. Perform the alignment using both pivot connections in the following procedures.

### REMOVE/REPLACE PIVOT BOLT

If an axle with QUIK-ALIGN pivot connections is found to be out of alignment (KINGPIN TO FRONT AXLE ALIGNMENT CHECK on page 12 or AXLE-AXLE ALIGNMENT CHECK on page 15) it must be adjusted as follows:

- Remove** and discard the existing shear-type bolt, TORQ-RITE® Nut and hardened flat washers from the pivot connection. If necessary, clean the surface rust from the alignment collars and frame bracket surface and inspect for excess wear. Replace if worn.

**⚠ CAUTION: The pivot bolt and nut are not reusable. A new shear-type bolt and hex nut must be installed and sheared to achieve the proper pivot connection torque and clamp force. See Figure 1 on page 4.**

2. Install a new shear-type bolt, TORQ-RITE® Nut and hardened flat washers into the axle pivot connection to be adjusted, but **do not fully tighten at this time**. The pivot connection fasteners should be tight enough to hold the flanged eccentric collar in place between the alignment guides and flat against the frame bracket, but loose enough to permit the hardened flat washers to rotate freely. See Figure 1 on page 4.

**⚠ CAUTION: DO NOT APPLY anti-seize compound or additional lubricant to pivot connection hardware. A dry lubricant coating has been applied to the threads of the pivot connection bolt and nut. Do not allow undercoating, paint, surface coatings, or any other commonly used compounds to contact the threads of the pivot connection fasteners. These compounds can act like a lubricant, reducing the friction between the threads of the nut and bolt. This can lead to overtightened fasteners, unpredictable pivot connection clamp loads and unreliable axle alignments. Threads should be clean, dry and free of contamination, as supplied by Hendrickson.**

**IMPORTANT:** The eccentric and concentric collar must remain flat against the frame bracket throughout the alignment procedure (Figure 35-A, page 25). If the pivot connection fasteners are too loose, the eccentric collar may raise up on the alignment guide, resulting in an improper alignment (Figure 35-C). If this condition occurs during alignment, refer to the raised eccentric collar information in PIVOT CONNECTION HARDWARE TROUBLESHOOTING on page 25.

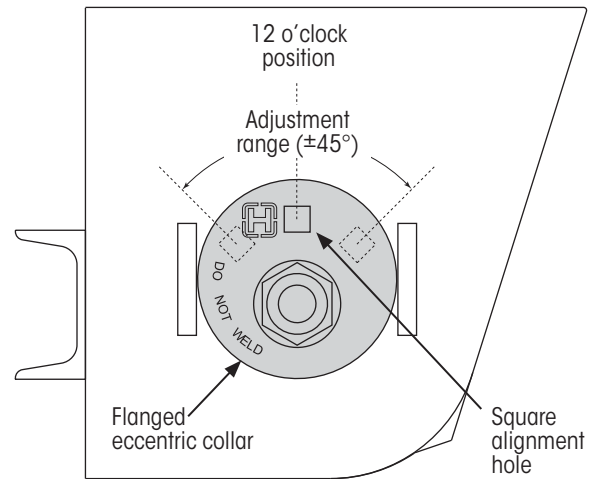

Figure 24: Eccentric collar orientation details

3. **Inspect** the orientation of the square alignment hole in the flanged eccentric collar (Figure 24). The square alignment hole must be at the 12 o'clock position, which is the middle of the alignment adjustment range.  
  
If the square alignment hole is not at the 12 o'clock position, **insert** a 1/2 inch breaker bar into the square alignment hole in the flanged eccentric collar and rotate the collar until the square hole is at the 12 o'clock position.
4. **Recheck** applicable KINGPIN TO FRONT AXLE ALIGNMENT CHECK, STEP 5 ON PAGE 14, or AXLE-AXLE ALIGNMENT CHECK, step 8 on page 15, to each wheel-end extender pointer.
  - A. If the axle is within target values, advance to TIGHTENING PIVOT CONNECTION.
  - B. If adjustment is still required, **insert** a 1/2 inch breaker bar (Figure 7 on page 6) into the square alignment hole in one of the flanged eccentric collars and continue to next step.
5. **While rotating** the flanged eccentric collar (on the outboard side of the frame bracket), **tap** on the flanged concentric collar (on the inboard side of the frame bracket) with a rubber mallet.

**IMPORTANT:** The tapping allows the concentric and eccentric collars to move and adjust in unison. If the collars do not move and adjust in unison, the concentric collar may wedge against the frame bracket (Figure 35-B on page 25), causing an inaccurate alignment and an improper pivot connection that could potentially loosen. If this condition occurs during the alignment procedure, refer to the “wedged collar” information in PIVOT CONNECTION HARDWARE TROUBLESHOOTING on page 25.

**NOTE:** Adjust the **axle forward** by rotating the collar clockwise or adjust the **axle rearward** by rotating the collar counterclockwise.

**IMPORTANT:** There is no change in axle adjustment when the flanged eccentric collar is rotated beyond 45 degrees from the 12 o’clock position in either the fore or aft direction.

## TIGHTENING PIVOT CONNECTION

If necessary, refer to TORX® SOCKETS on page 4.

1. **Visually inspect** the eccentric and concentric collars on the pivot connection to ensure they are in place between the alignment guides and flat against the frame bracket.  
  
If a collar is wedged or raised, tap on the concentric collar (on the inboard side of the frame bracket) with a rubber mallet until it lays flat.
2. **Hand tighten** pivot connection fasteners until hardened flat washers do not rotate freely.
3. Repeat Step 4 measurements.
  - A. If the measurement is **not within target value**, return to Step 5.
  - B. If the measurement is **within the target value**, proceed to next step.

4. Using an E20 TORX® socket, **tighten** the shear-type bolt on the front axle pivot connection until the TORX head shears off. This ensures the proper torque of 550±45 ft. lbs. (750±50 Nm).

**⚠CAUTION:** An improperly torqued pivot connection can result in injury and/or property damage.

**Anyone who assembles or reassembles pivot connections (OEMs, dealers, repair facilities, etc.) is responsible for proper installation of the shear-type bolt.**

**Failure to reach required torque can result in an insufficient clamp load and unreliable axle alignment.**

**Do not attempt to reuse a shear-type bolt.**

**Always wear eye protection when operating pneumatic tooling.**

**Make sure socket is securely fastened to pneumatic tooling.**

## WELDED COLLAR AXLE ADJUSTMENT

If an axle with a welded collar pivot connection is found to be out of the acceptable alignment specification, it must be realigned as follows:

1. **Select** one side of the axle and **carefully grind or cut** the welds securing the inboard and outboard alignment collars to the frame bracket.

**IMPORTANT: DO NOT** remove the 1 $\frac{1}{8}$  inch heavy hex cap screw and nut or Huck® Fastener. Axle alignment with the welded collar style pivot connection does not require pivot joint disassembly.

**IMPORTANT:** HT™ Series model HT250U Y-beam underslung suspension alignment slots are on the beam assembly. The inboard and outboard alignment collars are welded to the beam assembly itself.

2. Recheck applicable KINGPIN TO FRONT AXLE ALIGNMENT CHECK, step 5 on page 14, or AXLE-AXLE ALIGNMENT CHECK, step 8 on page 15, to each wheel-end extender pointer.
  - A. If the axle is within target values, skip the next step.
  - B. If adjustment still required, continue to next step.

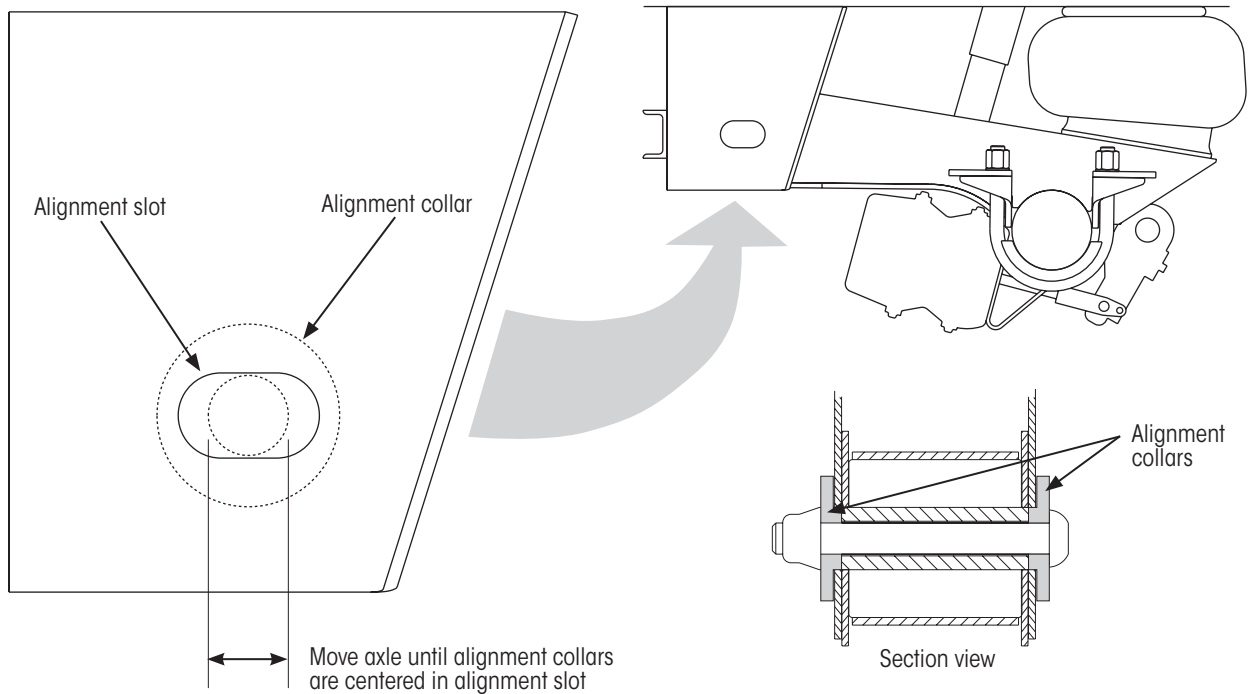

Figure 25: Axle positioning on the welded-collar type frame bracket when major adjustment (both axle ends) is necessary

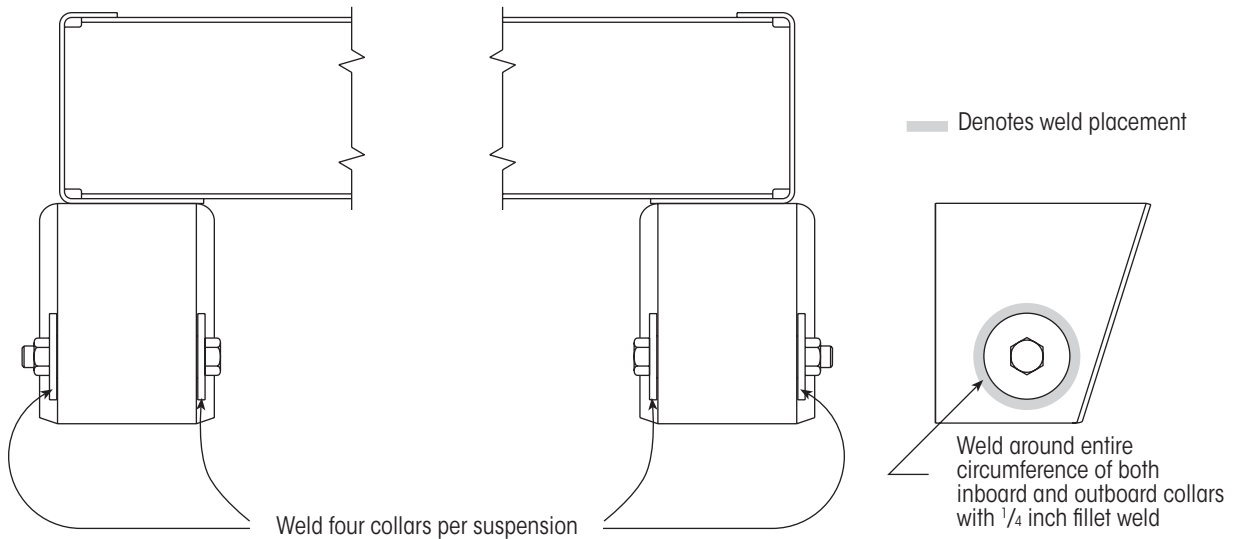

Figure 26: Welding locations on welded collars

3. **Move** the loose axle end fore or aft until the measurement is within the target value.
 

**If the alignment collars can no longer be moved** within the alignment slots in the frame bracket and the axle is still not within the target value,

  - A. The welds on the inboard and outboard alignment collars on the other side of the axle must also be **carefully ground or cut** loose.
  - B. With both axle ends loose, **move** the axle until the alignment collars are centered in the frame bracket alignment slots (Figure 25).
  - C. The axle can now be repositioned on both sides. Repeat [Step 2](#) and [Step 3](#) until the alignment is within the target value.
4. **Remove** all equipment used to reposition the axle.
5. **Tack** weld the alignment collars in place.
6. **Verify** correct alignment (repeat [Step 2](#)).
7. **Weld** around the inboard and outboard collars on each end of the axle with a 1/4 inch fillet weld ([Figure 26](#)).
8. **Verify** the weld goes around the entire circumference of all four collars.



## CONNEX ST AXLE ALIGNMENT

Alignment should be performed only after steps are taken to ensure the self-steer spindles and wheels are properly aligned with axle center and toe is correct. If so, AXLE-AXLE ALIGNMENT CHECK on page 15 can be used to align a self-steer axle.

**IMPORTANT:** A self-steer axle must not be used as the primary front most axle for axle-axle alignment in these procedures (see Figure 27).

### Before getting started, ensure:

- A. Tires are the same size, air pressure and tread pattern.
- B. Hubs, drums and brakes are identical.
- C. All wheel-end components are identical for both left and right side.
- D. All suspension bushings and components are Hendrickson Genuine Parts, correctly assembled, adjusted, in good condition and functioning properly. Refer to Hendrickson literature number B106 Pivot Bushing Inspection Procedure.
- E. No lateral or fore-aft **movement** in kingpin.
- F. Lubricate as needed per decal T60001.

If issues exist, refer to T62001 CONNEX ST Self-steer Axle Maintenance Procedures. For recommended suspension inspection and lubrication, refer to L578 Preventive Maintenance Guide.

**IMPORTANT:** Corrections must be made before performing **CONNEX ST** axle alignment checks or adjustments.

## CONNEX ST ALIGNMENT SUMMARY

**IMPORTANT:** Although toe is independent of axle alignment, it should be verified and checked **before** performing axle-axle alignment.

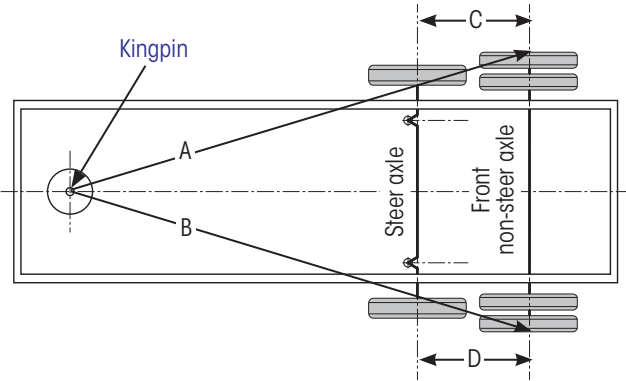

Figure 27: Self-steer axle alignment measurements

To properly align the self-steer axle, perform these procedures in this order:

1. If not already done, **check and align** the front (non-steer) axle thrust angle (Figure 27, A=B) according to KINGPIN TO FRONT AXLE ALIGNMENT CHECK on page 12.
2. **Lock** the self-steer axle following LOCKING THE SELF-STEER AXLE on page 22.
3. **CHECK AND ADJUST TOE** on page 23.
4. **Follow** AXLE-AXLE ALIGNMENT CHECK on page 15 (Figure 27, C=D) and ensure it is within specifications listed in Table 5 on page 13.
5. If adjustment to alignment is required, **follow** QUICK-ALIGN® AXLE ADJUSTMENT on page 16.
6. **Remove** dowel pin from centering lock hole.
7. Restore lock-straight mechanism and self-steer axle to normal operation.

## LOCKING THE SELF-STEER AXLE

During alignment or adjustment of the self-steer axle, the lock-straight assembly (Figure 29) is used to lock the tie rod in the center position while the wheels are checked and/or adjusted to point straight forward on the trailer, with toe.

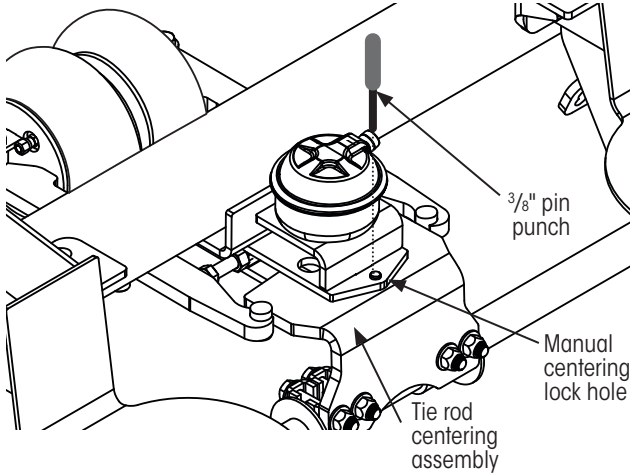

Figure 28: Locking wheels to straight position

1. **Lift** self-steer axle until tires are off the ground.
2. **Manually steer** wheels in both directions to ensure no contact with trailer.
3. **Center wheels and insert** a 3/8 inch pin punch (or equivalent) into manual centering lock holes, as shown in Figure 28.

**IMPORTANT:** Using the manual centering lock hole, it is not necessary to air up the lock-straight actuator or chamber.

4. Inspect to ensure the following:
  - A. There is **no damage** to lock-straight mechanism or other suspension components.
  - B. No excess **wear** at the four lever arm contact points (Figure 29) and pivot points.
  - C. All four contact points (Figure 29) have **no gaps**.
  - D. **Measure** to ensure, in Figure 30,  $R_1 = R_2 \pm 0.09$  inch (2.3 mm).
5. **Lower** suspension back on the ground and apply normal equalized load on the axle.

**IMPORTANT:** Corrections must be made before performing CONNEX ST axle alignment checks or adjustments.

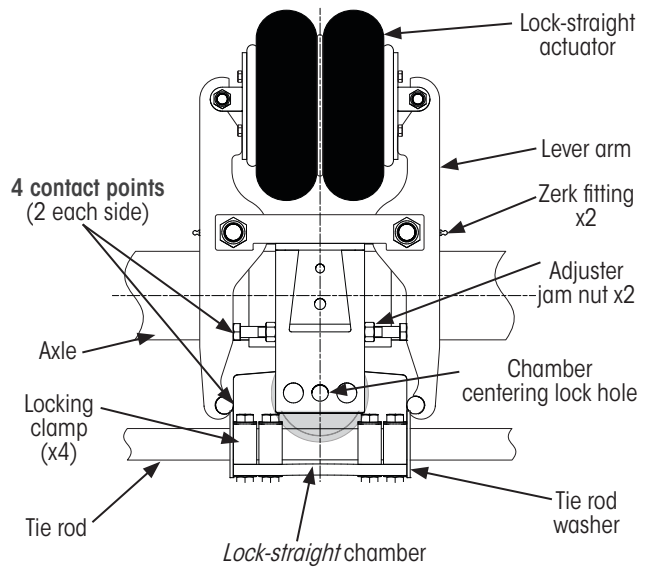

Figure 29: Self-steer axle lock-straight mechanism (bottom view)

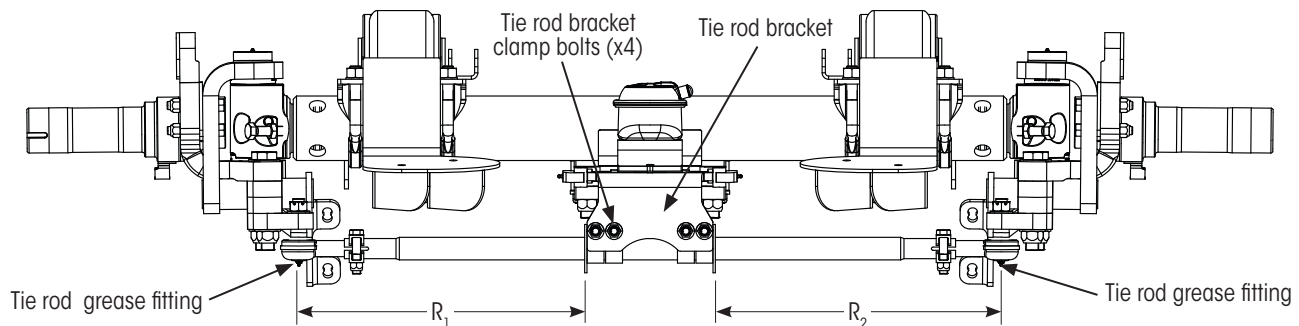

Figure 30: Tie rod end clamp orientation

## CHECK AND ADJUST TOE

A proper toe setting is important to ensure wheel stability and minimize scrubbing of the tires.

**NOTICE:** All alignment should be performed while the trailer is unloaded and setting on a level surface. Adjusting while loaded can result in an excessive toe setting and tire wear while unloaded.

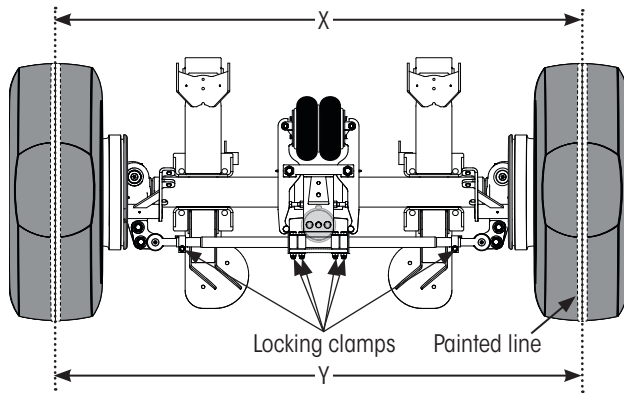

Figure 31: Toe Measurements (bottom view)

1. **Raise** axle until both tires clear the surface.
  2. If not done so, **perform** LOCKING THE SELF-STEER AXLE on page 22.
- IMPORTANT:** If with dual wheels, measure toe between the center tread of inner tires.
3. While rotating wheel, **paint** a line around the center of the tire tread, full circle (Figure 31).
  4. **Rotate wheel and scribe** a narrow consistently centered line all the way around in the painted line on the tire tread. This will aid in the measurement of "X" and "Y".
  5. **Lower** wheels back to the surface and apply normal equalized load on the axle.

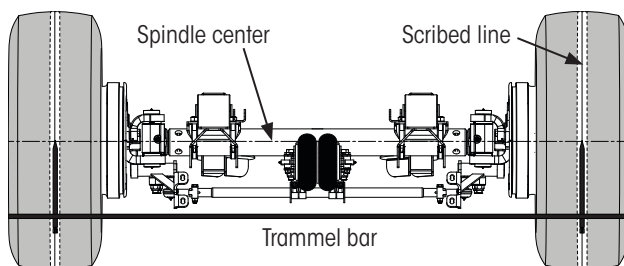

Figure 32: Measuring X and Y dimensions

6. **Ensure** the trailer is at the designed ride height. Refer to Hendrickson literature number L459 Checking Trailer Ride Height.

**IMPORTANT:** To ensure consistent measurements, X and Y measurements should be made at the same height, center of spindle, on the tires (Figure 32). **This measurement should always be taken with the suspension at ride height.**

7. **Measure and record** measurements for X and Y.

AXLE LOAD	TOE	
	Inch	mm
<b>Unloaded</b>	0.625 +0.06 -0.0	15.88 +1.5 -0.0

Toe-in = "X" smaller than "Y"  
 Toe-out = "X" larger than "Y"  
**IMPORTANT:** toe-out (negative toe) is not allowed.

Table 7: Recommended Toe

8. **Subtract** X from Y. The specification for toe is listed in Table 7.
  - A. If toe is negative (toe-out) or **not within** specification, continue with the next step.
  - B. If toe is positive (toe-in) and **within** the specified tolerance, no adjustment is required. Go to Step 13.
9. **Raise** axle until both tires are off the surface.
10. **Loosen** all tie rod locking clamps Figure 31. Skip this step if already loose.

**NOTE:** If properly positioned, tie rod washers (Figure 29 on page 22) should maintain wheel center position after clamps are loosened. These washers are typically tack welded in position during initial suspension installation or when replacing a tie rod assembly.

11. **Rotate** the tie rod to correct toe-in.
12. **Repeat** the procedure from Step 5 until the desired Toe-in value (specified in Table 7) is reached.
13. If toe adjustments were made, ensure all clamps are properly tightened, refer to TIGHTENING TIE ROD CLAMPS on page 24.
14. **Remove** dowel pin from centering lock hole.
15. **Restore** lock-straight mechanism and suspension to normal operation.

## TIGHTENING TIE ROD CLAMPS

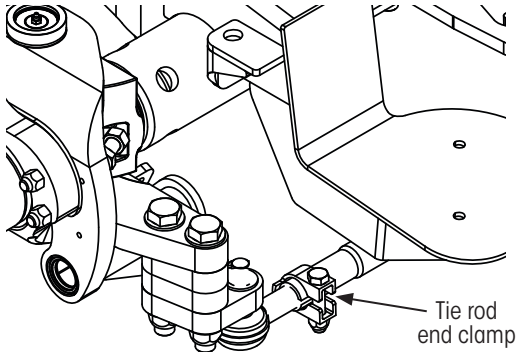

**NOTICE:** The clamp and bolt must be orientated as shown to avoid interference among moving parts.

Figure 33: Tie rod end clamp orientation

1. Once the desired Toe-in setting is achieved, **orient** tie rod end clamps (Figure 33) to provide adequate clearance for trailing arms during operation.
2. **Tighten** tie rod end locking clamp bolts to  $55 \pm 5$  ft. lbs. ( $75 \pm 5$  Nm) of torque.

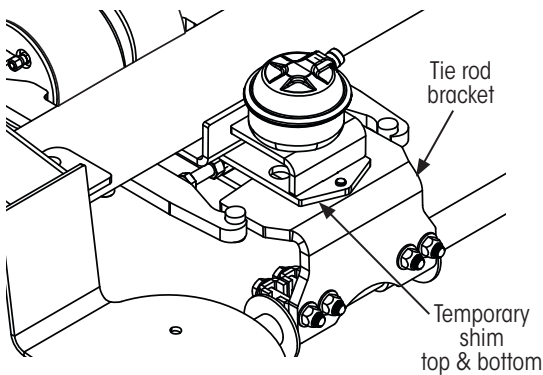

Figure 34: Aligning tie rod lock plate

3. **Insert** temporary shims above and below tie rod bracket (Figure 34) to evenly space (center) the tie rod bracket vertically in lock-straight assembly.

**IMPORTANT:** The tie rod bracket must be positioned to move freely within the lock-straight assembly.

4. **Verify**  $R1 = R2 \pm 0.09$  inches ( $\pm 2.3$  mm) (FIGURE 31: TOE MEASUREMENTS (BOTTOM VIEW) on page 23). **Tighten** tie rod bracket clamp bolts (Figure 30) to  $95 \pm 5$  ft. lbs. ( $130 \pm 5$  Nm) of torque.
5. **Remove** dowel pin from the centering lock hole (Figure 28).
6. **Remove** shims inserted in Step 3.

**PIVOT CONNECTION HARDWARE TROUBLESHOOTING**

Figure 35: QUIK-ALIGN® Pivot connection hardware positioning

## QUIK-ALIGN®

### RAISED ECCENTRIC COLLAR

#### Appearance

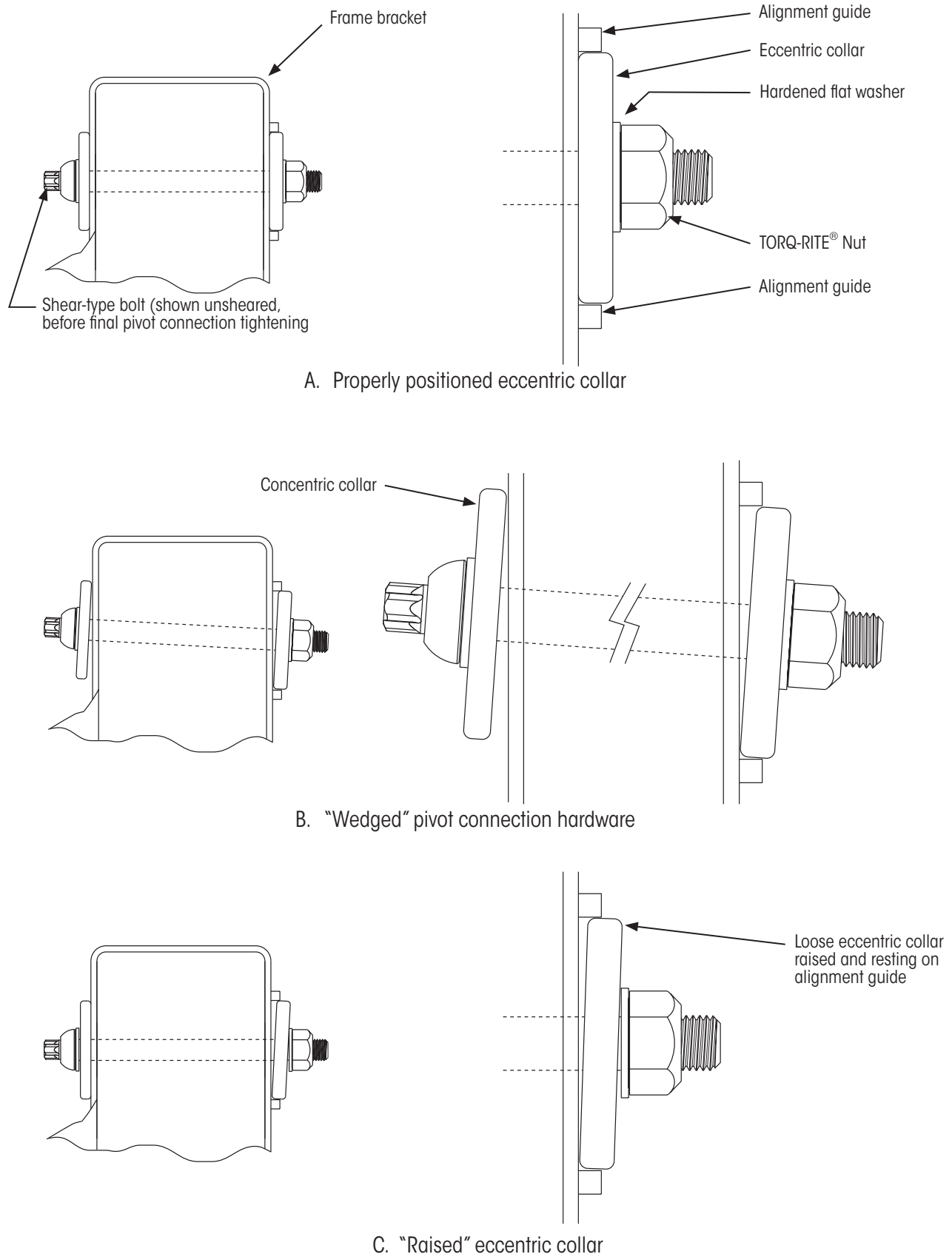
The eccentric collar is not flat against the frame bracket; it is resting on an alignment guide. However, the shear-type bolt is properly positioned and the concentric collar is flat against the frame bracket (Figure 35-C, page 25).

#### Causes

When installing the TORQ-RITE® Nut on the shear-type bolt, the nut was not tightened sufficiently. Initially, the pivot connection fasteners must be tight enough to hold the eccentric collar in place between the alignment guides and flat against the frame bracket, but loose enough to permit the hardened flat washers to rotate freely. The loose nut allowed the eccentric collar to move freely and work its way onto an alignment guide.

#### Results

Initially, the alignment appears to be accurate. However, when the eccentric collar eventually slips off the alignment guide, the pivot connection will become loose and alignment accuracy will be lost.

#### Solutions

During assembly, tighten the TORQ-RITE® Nut so the eccentric collar is in place against the alignment guides and flat against the frame bracket, between the alignment guides, but loose enough to permit the hardened flat washers to rotate freely.

Visually inspect the eccentric collar after alignment. If the eccentric collar is resting on an alignment guide in the "raised" position and the TORX®-head on the shear-type bolt has been sheared, remove and discard the pivot connection hardware and redo the alignment using new pivot connection hardware. If the eccentric collar is resting on an alignment guide in the "raised" position but the TORX-head on the shear-type bolt has not yet been sheared, carefully loosen the pivot connection and redo the alignment.

### WEDGED PIVOT-CONNECTION HARDWARE (NOT FLAT AGAINST FRAME BRACKET)

#### Appearance

The pivot-connection hardware (collars, washers, etc.) is not flat against the frame bracket. The pivot bolt and collars are "cockeyed" and not in their proper positions (Figure 35-B, page 25).

#### Causes

While being adjusted, the inboard collar did not move in unison with the outboard collar.

#### Results

An inaccurate alignment and an improper pivot connection that could potentially loosen.

#### Solutions

Tap on the inboard collar with a rubber mallet while rotating the outboard collar.

Visually inspect the pivot connection after alignment. If the collars are "wedged" against the frame bracket and the pivot connection shear fastener has been sheared, remove and discard the pivot connection hardware and redo the alignment using new pivot connection hardware. If the collars are "wedged" against the frame bracket but the pivot connection shear fastener has not yet been sheared, carefully loosen the pivot connection and redo the alignment.



## LOOSE PIVOT CONNECTION

### Appearance

Refer to [Figure 37](#) and [Figure 38](#). The pivot bolt appears to be loose and the frame bracket side material is polished or surface coating is smudged from collar movement, or worse.

### Causes

The most likely cause is a loose pivot connection, possibly due to reasons defined in [Figure 35](#) or:

- Improperly installed pivot bolt.
- Contaminants, such as undercoating, paint, anti-seize, etc., on pivot bolt and hardware during installation.
- Installer did not shear the bolt ([Figure 36](#)).
- Unusually thick surface coat under alignment collar ([Figure 4](#) on page 5).

### Results

Misaligned axle, damage to frame bracket, bushing (ends of the bushing inner metal) and pivot connection components.

Inspection for wear should be performed on the following:

- Alignment slot(s) within frame bracket - alignment collar(s), See [Figure 35](#)
- Bushing and the ends of the bushing inner metal that contacts frame bracket inside walls.

In severe cases, if gone unnoticed, movement against the edge of the frame bracket alignment slot ([Figure 39](#)) causes:

- A wallowed out alignment slot, See [Figure 38](#)
- Wearing down of the nose on the collar, which extends through the alignment slot, See [Figure 39](#)
- If the nose is worn through, can also wear into the pivot bolt.

No visual wear is acceptable, replace as required.

### Solutions

Replace frame bracket and pivot connection hardware. If necessary, replace bushings.

**IMPORTANT: The pivot bolt and hardware must be replaced and cannot be reused. Refer to PIVOT CONNECTION - FRAME BRACKET on page 5 for more information.**

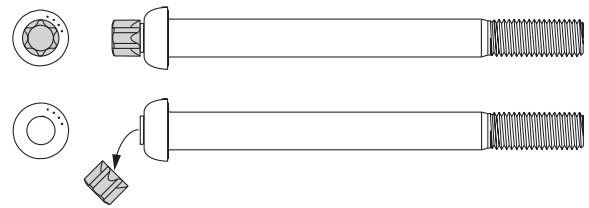

Figure 36: Shear style pivot bolt (Shown before and after shearing)

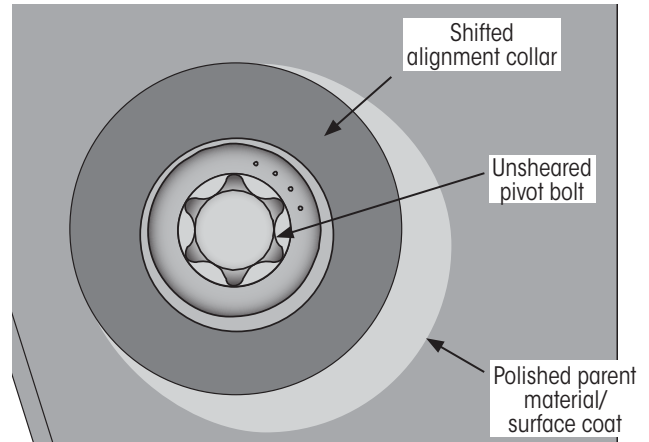

Figure 37: Loose pivot bolt, not sheared in this example

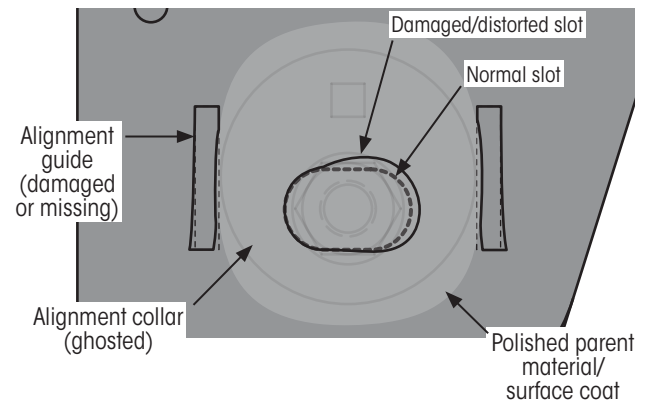

Figure 38: Damaged/distorted alignment slot

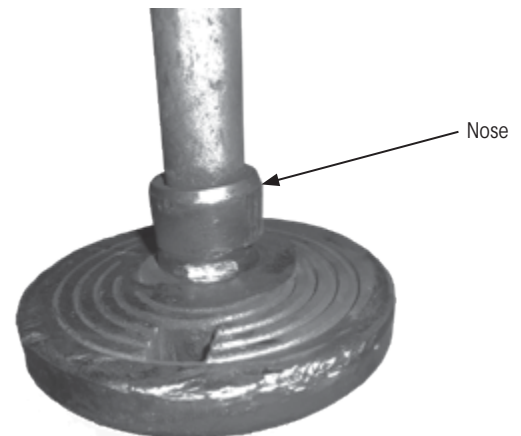

Figure 39: Loose pivot bolt collar nose damage

## APPENDIX A: AXLE TARGET VALUE SAMPLE CALCULATION

Determine both axle target values as follows:

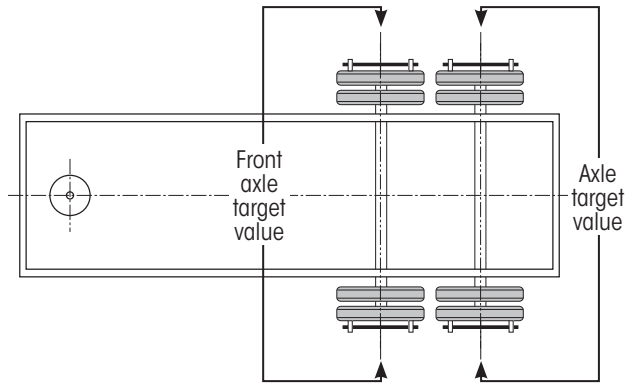

Figure 40: Point-to-point measurement for target values

1. **Measure** the point-to-point width of the installed wheel-end extenders (Figure 40).

As an alternative to measuring the point-to-point width of the wheel-end extenders, the following method can be used to approximate the distance (Figure 41):

$$\frac{\text{wheel face-to-face distance} + 2(\text{wheel-end extender length})}{\text{point-to-point width of the installed wheel-end extenders}}$$

While the wheel face-to-face distance will vary with different wheel equipment, the following method can be used to approximate the distance without significantly impacting the alignment tolerance:

79.2" for a 77.5" axle track  
73.2" for a 71.5" axle track

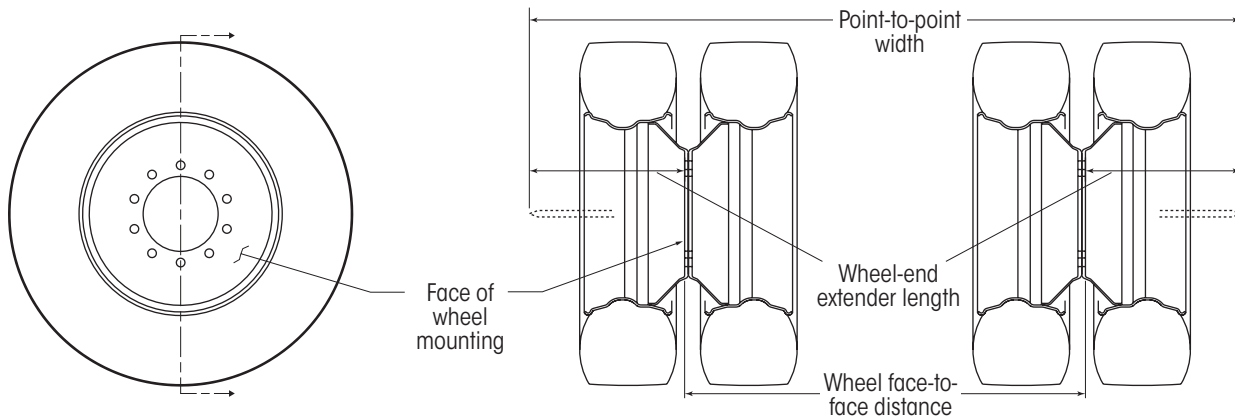

Figure 41: An alternative to measuring the point-to-point width of the wheel-end extenders

2. For the front axle, multiply this width by 0.00175<sup>1</sup>. The resulting product is the front axle target value.

**EXAMPLE E:** Calculating thrust angle target value, sine=0.1°:

Suppose the point-to-point width of the wheel-end extenders is 122.625 inches. Multiplying this by the 0.00175 constant produces:

$$122.625" \times 0.00175 = \pm 0.215"$$

This provides the front axle (thrust angle) target value.

3. For the axle, multiply this width by 0.00087<sup>2</sup>. The resulting product is the axle target value.

**EXAMPLE F:** Calculating thrust angle target value, sine=0.05°:

Suppose the point-to-point width of the wheel-end extenders is 122.625 inches. Multiplying this by the 0.00087 constant produces:

$$122.625" \times 0.00087 = \pm 0.107"$$

This provides the axle (scrub angle) target value.

**NOTE:** If more than two axles, repeat Step 1 and Step 3 for each axle. Reference all measurements to front axle.

<sup>1</sup> For axle to kingpin distances of 10 feet or more, the 0.00175 constant can be approximated by using the sine of 0.1°.

<sup>2</sup> For axle to kingpin distances of 10 feet or more, the 0.00087 constant can be approximated by using the sine of 0.05°.



Call Hendrickson at **866.RIDEAIR (743.3247)** for additional information.



**TRAILER COMMERCIAL VEHICLE SYSTEMS**

2070 Industrial Place SE  
Canton, OH 44707-2641 USA  
866.RIDEAIR (743.3247)

330.489.0045 • Fax 800.696.4416

**Hendrickson Canada**

250 Chrysler Drive, Unit #3  
Brampton, ON Canada L6S 6B6  
800.668.5360

905.789.1030 • Fax 905.789.1033

**Hendrickson Mexicana**

Circuito El Marqués Sur #29  
Parque Industrial El Marqués  
Pob. El Colorado, Municipio El Marqués,  
Querétaro, México C.P. 76246

+52 (442) 296.3600 • Fax +52 (442) 296.3601