

H TECHNICAL PROCEDURE

MAXX22T™ AIR DISC BRAKE

SUBJECT: Installation and
Maintenance Procedures

LIT NO: T72009

DATE: April 2015



TABLE OF CONTENTS

Conventions Applied in this Document	3
Explanation of Signal Words	3
Links	3
General Service Notes	3
During Service:	3
Important Safety Notices	3
Contacting Hendrickson	5
Phone	5



Email.....	5
Literature.....	6
Preparing Trailer for Service.....	6
Introduction.....	7
Description Of MAXX22T Disc brake.....	7
Functional Description.....	7
Disc brake Inspection.....	9
General Inspection.....	9
Checking Adjuster Operation.....	9
Checking Brake Pad Wear.....	10
Manually Measuring Brake Pad Wear.....	11
Inspecting The Brake Rotor.....	11
Checking Rotor Thickness.....	11
Checking The Condition Of The Brake Rotors.....	12
Checking The Runout Of The Brake Rotors.....	12
Checking Guide Pin Bearing Play.....	13
Replacing ADB Components.....	14
Replacing The Brake Pads.....	14
Removing The Brake Pads.....	14
Checking Brake Caliper Movement.....	16
Checking The Adjuster Unit (Clamping Unit).....	18
Installing Brake Pads.....	18
Replacing The Brake.....	20
Removing The Brake.....	20
Installing The Brake.....	21
Replacing The Brake Chamber.....	22
Removing The Brake Chamber.....	22
Installing The Brake Chamber.....	22
Replacing Protection boots.....	24
Summary of procedures.....	24
Removing Brake Caliper from Brake Carrier.....	24
Replacing Guide Pin Boots And Bushings.....	25
Mounting Brake Caliper to Brake Carrier.....	28
Replacing Adjuster Piston Boot.....	30
Replacing Adjuster Boot.....	32
Replacing Dust Shield.....	35
Appendix A: Wrench Size And Tightening Torques.....	36
Appendix B: ADB Tools.....	37
Basic Tools.....	37
Tools for MAXX22T™.....	38
Appendix C: Exploded view of Replacement Parts.....	39



CONVENTIONS APPLIED IN THIS DOCUMENT

This section explains the techniques used in this document to convey important information, safety issues, how to contact Hendrickson and how to apply hyperlinks.

EXPLANATION OF SIGNAL WORDS

Hazard signal words (such as DANGER, WARNING or CAUTION) appear in various locations throughout this publication. Information accented by one of these signal words must be observed at all times. Additional notes are utilized to emphasize areas of procedural importance and provide suggestions for ease of repair. The following definitions comply with ANSI Z535.4 and indicate the use of safety signal words as they appear throughout the publication.

 DANGER: INDICATES IMMEDIATE HAZARDS WHICH WILL RESULT IN SEVERE PERSONAL INJURY OR DEATH.

 WARNING: Indicates hazards or unsafe practices which could result in severe personal injury or death.

 CAUTION: Indicates a hazardous situation which, if not avoided, could result in minor or moderate injury.

NOTICE: Indicates hazards or unsafe practices which could result in damage to machine or equipment.

IMPORTANT: An operating procedure, practice or condition that is essential to emphasize.

 Safety alert symbol used to indicate a condition exists that may result in personal injury or harm to individuals. It must be applied to DANGER, WARNING and CAUTION statements, which emphasize severity.

LINKS

Links are identified by a dark grey line under the linked text. Internal links allow the reader to jump to a heading, step or page in this document. External links open the website or document referenced.

GENERAL SERVICE NOTES

IMPORTANT: Special attention should be paid to the information included in EXPLANATION OF SIGNAL WORDS.

Before you begin:

Read, understand and comply with:

- All maintenance, service, installation and diagnostic instructions and procedures for Hendrickson, the trailer manufacturer and the repair facility.
- All signal word (CAUTION, WARNING and DANGER) statements to help avoid personal injury or property damage.
- Vehicle manufacturer's safety instructions when working on the vehicle.
- Vehicle manufacturer's instructions for recommended practices not described in this manual.
- All applicable governmental safety regulations.

DURING SERVICE:

- Work must be carried out by trained personnel.
- Sudden release of brake chamber springs (e.g. the spring brake part of the brake chamber or the brake return spring) may cause injury.
- Use recommended tools only.
- Before releasing trailer back into service, perform operational checks and test the trailer to make sure brakes are working correctly.

Hendrickson reserves the right to make changes and improvements to its products and publications at any time. Consult the Hendrickson website (www.hendrickson-intl.com) for the latest version of this manual.

IMPORTANT SAFETY NOTICES

Proper installation, maintenance, service and repair is important to the reliable operation of the suspension system. The procedures recommended by Hendrickson and described in this publication are methods of performing inspection, maintenance, service and repair.

The warnings and cautions should be read carefully to help prevent personal injury and to assure proper methods are used. Improper maintenance, service or repair can cause damage to the vehicle and



other property, personal injury, an unsafe operating condition or void the manufacturer's warranty.

To help ensure proper brake performance:

- Regularly check the wear limits of brake pads and brake rotors.
- Immediately replace worn or damaged brake rotors.
- Always replace brake pads by axle.

NOTE: Retainer springs are pre-assembled to brake pads.

- If any parts have been heavily damaged or are severely worn, (cracks for example), replace the entire brake following the instructions on [page 20](#).

⚠WARNING: A damaged brake chamber can result in serious or fatal injury during handling and use.

⚠WARNING: A damaged brake chamber can cause the brake system to not operate properly.

⚠CAUTION: To avoid injury and damage to brake components, manually cage the brake chamber prior to servicing brake.

⚠WARNING: DO NOT modify or rework parts without written authorization from Hendrickson. Use ONLY Hendrickson authorized replacement parts. Use of substitute, modified or replacement parts not authorized by Hendrickson may not meet Hendrickson's specifications. It can also result in failure of the part, loss of vehicle control and possible personal injury or property damage.

⚠WARNING: Always wear proper eye protection and other required PPE (personal protective equipment) when performing vehicle maintenance, repair or service. Follow federal, state and local regulations as appropriate.

⚠WARNING: Solvent cleaners can be flammable, poisonous and can cause burns. To help avoid serious personal injury, carefully follow the manufacturer's product instructions and guidelines and the following procedures:

- Wear proper eye protection.
- Wear clothing that protects your skin.
- Work in a well ventilated area.
- DO NOT use gasoline, or solvents that contain gasoline. Gasoline can explode.
- Hot solution tanks or alkaline solutions must be used correctly. Follow the manufacturer's recommended instructions and guidelines carefully to help prevent personal accident or injury.

⚠WARNING: The following precautions and considerations should be applied when handling brake lining:

- Compressed air or dry brushing should never be used for cleaning brake assemblies or work area.
- Follow applicable shop, local, state and federal safe practices for working with and disposal of brake lining materials.
- Hendrickson recommends that workers doing brake work should take steps to minimize exposure to airborne brake lining particles. Proper procedures to reduce exposure include working in well ventilated area, segregation of areas where brake work is done, use of local filtered ventilation systems or use of enclosed cells with filtered vacuums.
- Material Safety Data Sheets (MSDS) on this product are available online from Hendrickson:

www.hendrickson-intl.com/trailerlit



⚠CAUTION: A mechanic using a service procedure or tool which has not been recommended by Hendrickson must first satisfy himself that neither his safety nor the vehicle's safety will be jeopardized by the method or tool selected. Individuals deviating in any manner from the provided instructions assume all risks of consequential personal injury or damage to equipment.

NOTICE: When welding to or on the axle, take every caution to prevent bearing damage. When grounding welding equipment to axle, prevent current from passing through the wheel bearings.

A connection that places a wheel bearing between the ground cable connection and the weld area can damage the bearing by electric arcing.

CONTACTING HENDRICKSON

Contact Hendrickson Trailer Technical Services for technical assistance as needed. To do so, several options are available.

Prior to contacting Technical Services, have the following information about your vehicle and Hendrickson suspension available (all that apply):

- Suspension ID Tag information (Refer to Hendrickson Lit. No. L977 ID Guide, page 2 for tag location and details):
 - Suspension model number
 - Suspension serial number
 - Approximate number of suspension miles.
- Vehicle VIN number. Refer to trailer OEM manual for VIN plate location.
 - Trailer Type (van, reefer, flat bed, etc...)
 - Manufacturer
 - VIN (vehicle identification number)
 - In-service date¹

¹ If the in-service date is unknown or not available, the vehicle date of manufacture can be substituted.

- If applicable, description of the system problem, part number and/or part description of the reported non-functioning part.
 - Date of problem.
 - Where applicable: location of problem on suspension / trailer; e.g., road side, front axle, rear axle, curb side rear, etc...
 - Symptoms-
 - » Systems, components or function effected by problem.
 - » When does problem occur?
 - » How often does the problem occur?
 - » Etc...
- What troubleshooting and/or measurements have been performed?
- What service data literature do you have or need?
- Digital photos of suspension and damaged areas.
- Special application approval documentation (if applicable).

PHONE

Contact Hendrickson directly in the United States at **866-RIDEAIR (743-3247)**. From the menu, select:

- **Technical Services/Warranty** for technical information.
- Other selections include:
 - **Aftermarket Sales** for replacement parts information and ordering.
 - **Original Equipment Sales** for parts inquires and ordering for trailer manufactures.

EMAIL

For Hendrickson Trailer Technical Services, use the following e-mail address:

htts@hendrickson-intl.com



LITERATURE

If you suspect your version of this or any other Hendrickson manual is not “Up-to-Date”, the most current version is free online at:

www.Hendrickson-intl.com/TrailerLit

Available Hendrickson documentation can be viewed or downloaded from this site.

All Hendrickson online documentation are PDF files that require Adobe Acrobat Reader to open. This is a free application downloadable from Adobe’s home page (<http://get.adobe.com/reader/>).

Other relative Hendrickson literature may include:

NAME	DESCRIPTION
L496	Standard Service Wheel End
L578	Suspension Inspection & Lubrication Requirements
L583	Comprehensive Warranty Statement
L1063	Air Disc Brake Parts List
L1225	Air Disc Brake Application Guide
T71004	ADB Rotor (U-shape style) and Caliper Mounting
T72002	HXL7® Wheel-end Maintenance Procedures
T72006	HXL3® Wheel-end Maintenance Procedures
T72007	HXL5® Wheel-end Maintenance Procedures

Table 1: Relative literature

PREPARING TRAILER FOR SERVICE

NOTE: DO NOT service a suspension or any components that are under warranty without first contacting Hendrickson Technical Services. Refer to CONTACTING HENDRICKSON for details.

⚠WARNING: To prevent serious eye injury, always wear safety glasses when performing trailer maintenance and service.

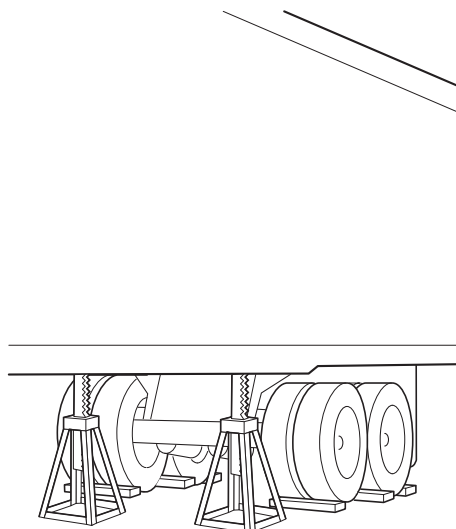

Figure 1: Trailer preparation

Before beginning any work on a trailer suspension system, use the following steps to help ensure conditions are safe. Refer to GENERAL SERVICE NOTES on page 3.

1. **Park** the trailer on a level, debris-free surface.
2. **Set** the trailer parking brakes.
3. To prevent the trailer from moving, **chock** the wheels of an axle not being raised.
4. **Exhaust** the air from the trailer suspension.

If required during service:

5. **Release** the trailer parking brakes.
6. Using a jack, **raise** trailer and/or axle until wheels clear the work surface.
7. **Support** the raised trailer with safety stands.

⚠WARNING: Do not work under a trailer supported only by jacks. Jacks can slip or fall over, resulting in serious personal injury. Always use safety stands to support a raised trailer.

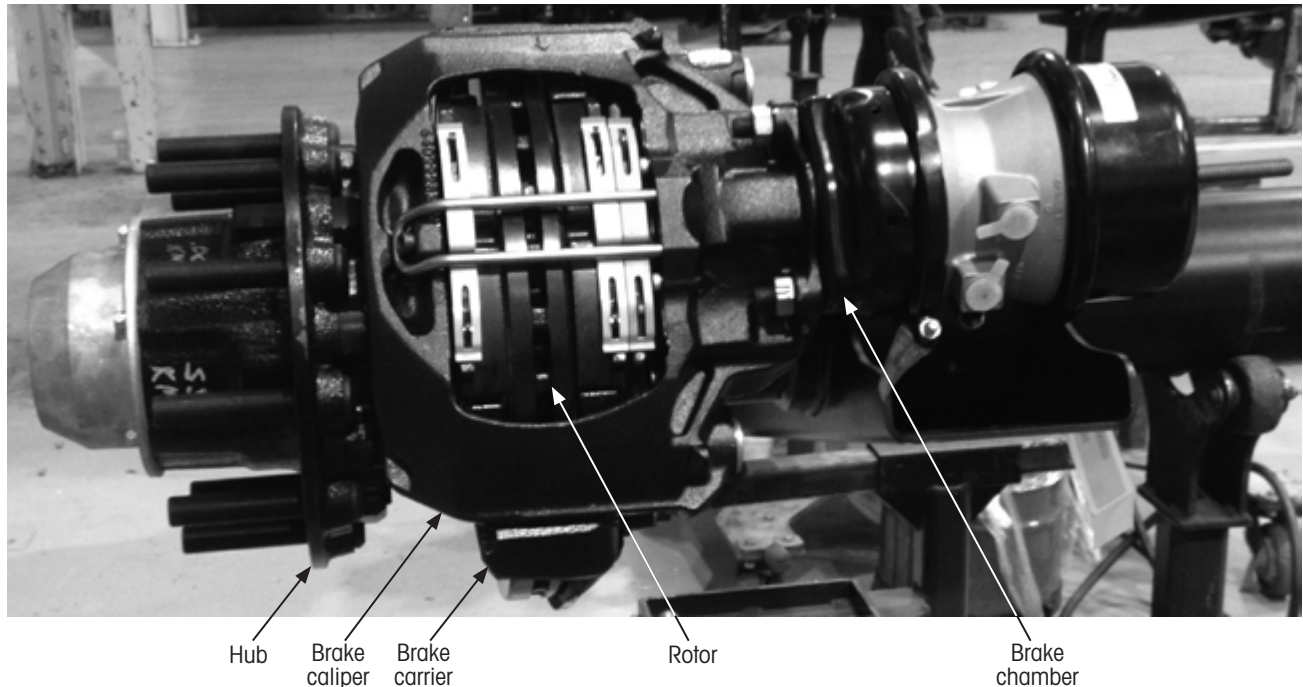

Figure 2: MAXX22T primary components

INTRODUCTION

This publication describes maintenance and repair of the MAXX22T™ air disc brake, including the individual operations and work processes required to replace components using available repair kits.

DESCRIPTION OF MAXX22T DISC BRAKE

The MAXX22T (Figure 2) is a pneumatic one-piston-brake intended for use as service, auxiliary and parking brake on commercial vehicle axles with a minimum size of 22.5" wheels.

Braking is actuated mechanically via a single diaphragm brake chamber or a spring brake chamber that is installed directly onto the brake caliper, thereby reducing the overall axial length of the brake. This enables optimal utilization of the application.

The complete disc brake consists of the following components: brake rotor, air brake chamber, brake carrier and brake caliper assembly (brake pads, pressure plate, pad retainer spring and pad retainer bar).

FUNCTIONAL DESCRIPTION

Axial movement of the brake caliper occurs on the guide pins (Figure 3). The brake pads are supported, guided and move axially in the brake carrier. The brake pads support is implemented by means of a pad retainer bar and hold-down springs.

The radially open design of the brake caliper enables simple brake pad replacements.

Compensating for pad wear, the actuating mechanism of the brake is equipped with a force-dependent, automatic adjuster mechanism. This mechanism maintains a preset pad to rotor clearance regardless of load and operating conditions.

NOTE: For exploded view with all parts called out. Refer to APPENDIX C: EXPLODED VIEW OF REPLACEMENT PARTS on page 39.

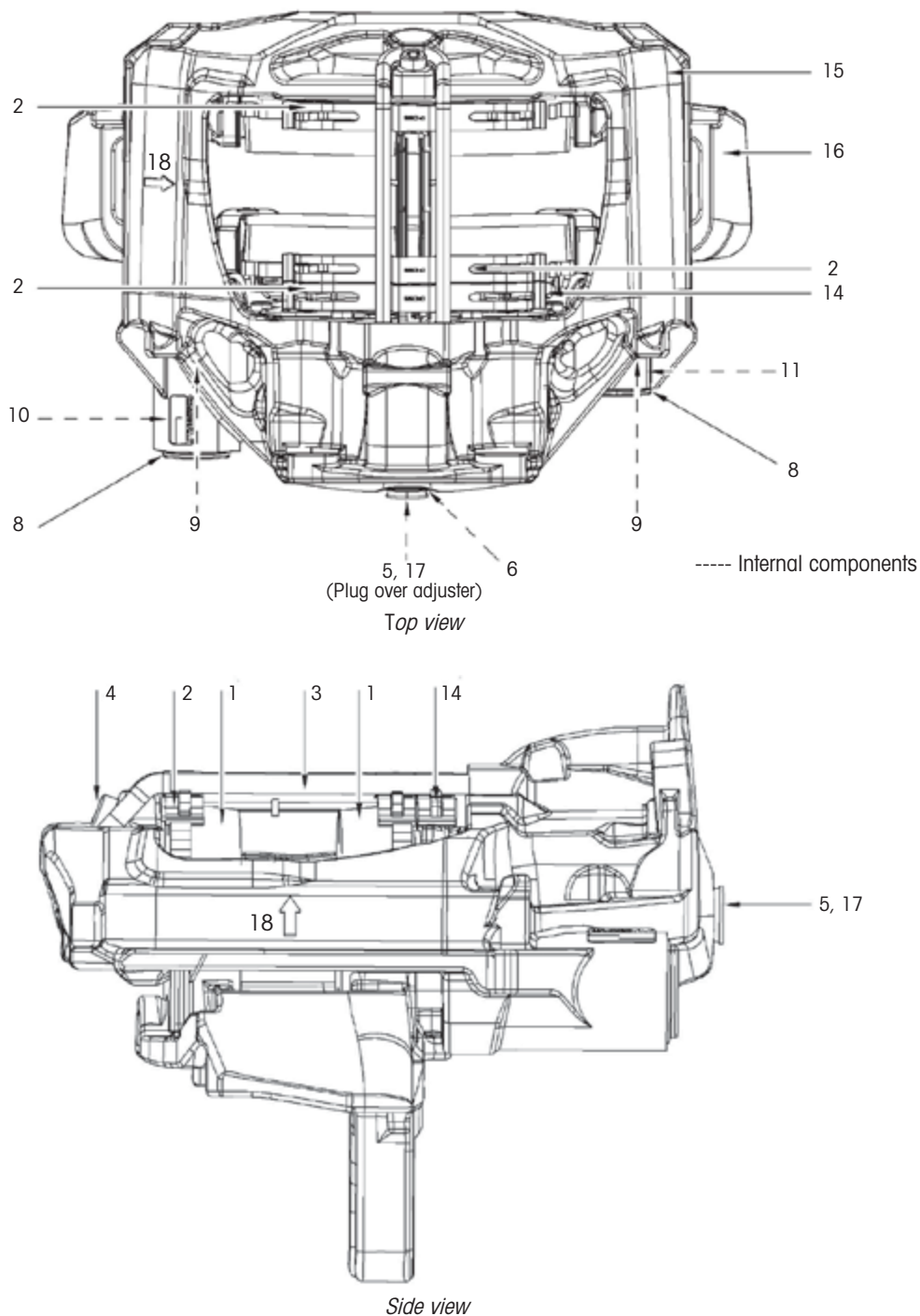

Figure 3: MAXX22T™ component locations (left brake shown)

Item	Name	Item	Name	Item	Name
1	Brake pads, outboard & inboard	8	Cap, guide pin	15	Brake caliper assembly
2	Spring, pressure plate retainer	9	Screw, guide pin	16	Brake carrier
3	Pad retainer bar	10	Guide pin (long)	17	Adjuster
4	Screw, pad retainer	11	Guide pin (short)	18	Rotor rotation driving forward
5	Plug, adjuster	12	Bushing, guide pins (Figure 91)	Some of the items listed in this table are included in one or more parts kits found in Hendrickson literature no. L1063 ADB Parts List	
6	Boot, adjuster	13	Boots, guide pin (Figure 91)		
7	Boot, adjuster piston	14	Pressure plate		

Table 2: MAXX22T components



DISC BRAKE INSPECTION

CAUTION: Observe all safety instructions. Refer to **IMPORTANT SAFETY NOTICES** on page 3. These instructions must be observed to help avoid personal injury and/or material damage.

GENERAL INSPECTION

NOTICE: The 8 mm adjuster components can be damaged if using open-ended wrenches or power tools.

Only use tools listed in **ADB TOOLS** on page 37 and described in these procedures.

Prior to removing the brake and during service:



Figure 4: Damaged guide pin cap

1. **Check** the brake system for damage and/or missing components (e.g. Figure 4).
2. **Replace** as needed.

CHECKING ADJUSTER OPERATION

NOTE: Directions of rotation and torques of the adjuster are listed in **Table 3** of **APPENDIX A: WRENCH SIZE AND TIGHTENING TORQUES** on page 36, Item I.

The brake chamber does not need to be removed in order to check the brake. The brake is shown, in this document, without the brake chamber for illustration purposes only.

Brake pads and pressure plate must be installed in order to check the adjuster.

Brake pads and pressure plate are held in place by the retainer springs and pad retainer bar.

NOTICE: Damage can occur at the inner seal when the plug removal tool is improperly positioned between brake caliper and outer edge of the adjuster boot.

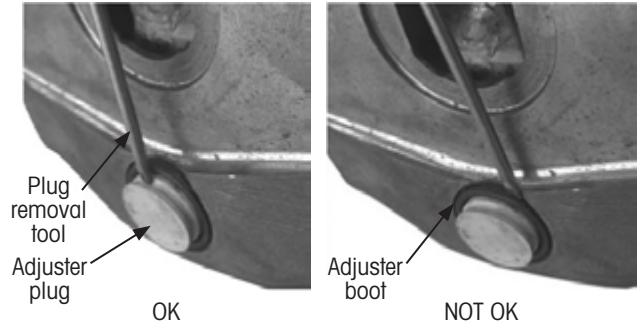

Figure 5: Removing adjuster plug

1. **Position** the plug removal tool at the adjuster plug when removing it (Figure 5).
2. **Carefully remove** the adjuster plug.

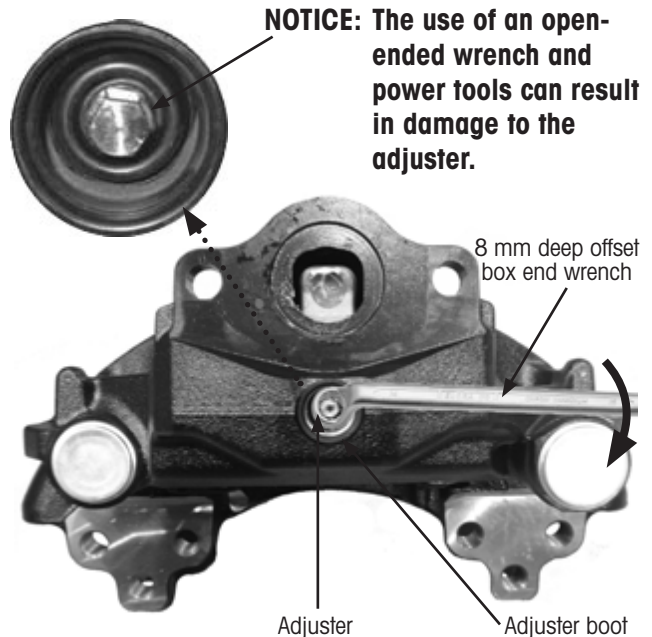

Figure 6: Checking adjuster movement.

3. **Check** the adjuster boot and plug for wear and damage. Discard and replace if worn or damaged.
4. Use an 8 mm deep offset box end wrench to **turn** the adjuster 1/2 turn clockwise (Figure 6).

NOTE: Checking the adjustment is only possible with a larger gap of 0.08" to 0.12" (2 to 3 mm). There must be sufficient space for the engaged wrench to rotate; it must not be obstructed when it is turned during adjustment.

- This step requires two people: **Gently apply the brake** 5 times (braking pressure is approximately 14.5 psi, 1 bar). If the adjuster functions correctly, the wrench will turn incrementally (Figure 6).

NOTE: With increasing adjustment the angle of rotation of the engaged wrench becomes smaller with each actuation. The adjuster is working correctly if the wrench rotates as described above.

- Remove** the offset box end wrench from the adjuster.
- Reinstall** the adjuster plug. Ensure a tight fit in the process. If not tight, replace.

NOTICE: Faults that might occur:

- The adjuster or the attached wrench does not turn (Figure 6).
- The adjuster or the attached wrench only rotates with the first actuation.
- The adjuster or the attached wrench rotates back and forth in same position with every actuation.

In these cases the adjuster is faulty and the brake must be replaced. Refer to REPLACING THE BRAKE on page 20.

CHECKING BRAKE PAD WEAR

General guidelines to checking brake pads and wear include:

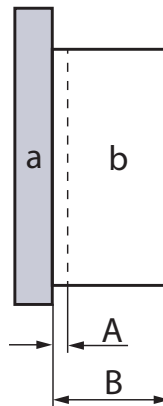

- A** = Minimum friction material thickness: 0.08" (2 mm)
- B** = Total friction material thickness: 0.90" (23 mm)
- a** = Backing plate
- b** = Brake pad friction material

Figure 7: Measuring brake friction material thickness

NOTICE: The brake pad thickness must be checked at regular intervals, in relation to vehicle use, during maintenance intervals.

Oil-contaminated brake pads must be replaced immediately.

Always replace all brake pads by axle, using a new retaining system for brake pads and pressure plates.

To avoid damaging the brake rotor, replace brake pads when friction material thickness (Figure 7, A) is at or close to the minimum. It must not be allowed to become less than 0.08" (2 mm), measured from the backing plate (Figure 7, a).

Replace the brake pads at a minimum friction material thickness $A < 0.08"$ (2 mm). Refer to REPLACING THE BRAKE on page 20.

Brake wear can be measured using the following method:



MANUALLY MEASURING BRAKE PAD WEAR

Wear on the middle of the brake pads can be measured with a tape measure or a ruler either at the long guide pin screw at the rotor run-in or at the short guide pin screw at the rotor run-out:

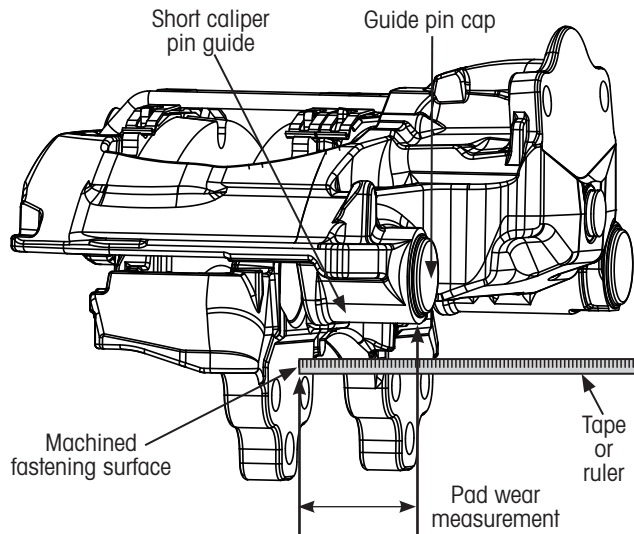

Figure 8: *Measuring brake pad wear*

As shown in Figure 8, measure the distance between the brake carrier machined fastening surface and the guide pin cap.

The measuring point on the brake carrier is the machined fastening surface attached to the torque plate, T71004.

Caliper movement, which results from pad and rotor wear, indicates the amount of wear. Measure movement (Figure 8) at the short caliper pin guide.

IMPORTANT: If wear exceeds 3.94" (100 mm), replace brake pads.

INSPECTING THE BRAKE ROTOR

IMPORTANT: Regularly check the wear limits of brake pads and brake rotors.

CAUTION: When brake pads and/or brake rotors are worn beyond limits, the braking effect is reduced and there is a risk of damage to brake components.

- IMPORTANT:**
- Always replace brake rotors by axle.
 - The brake rotors must be clean and free from grease.
 - Having installed new brake rotors, it is recommended that new brake pads be installed as well.

CHECKING ROTOR THICKNESS

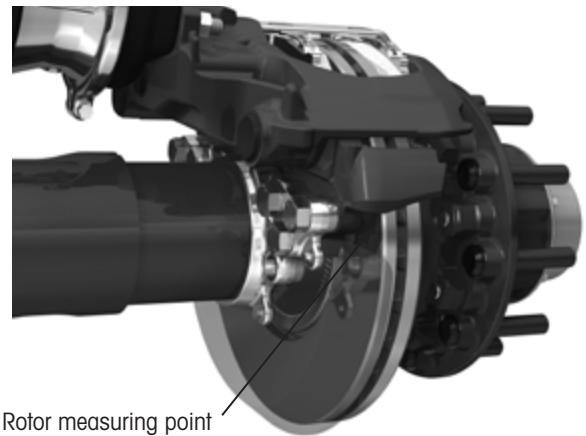

Figure 9: *Measuring rotor thickness*

1. **Measure** brake rotor thickness at the braking area (friction surface) at 3 points, 120° apart. Refer to Figure 9, Figure 10 and Figure 11 for rotor condition examples and measurements.

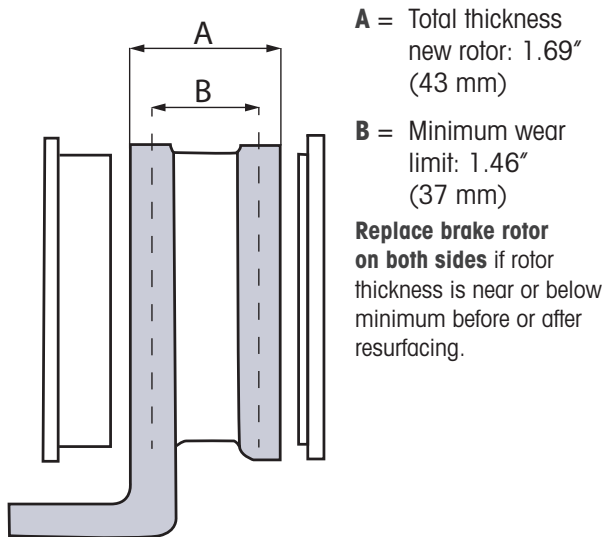

Figure 10: Rotor thickness

CHECKING THE CONDITION OF THE BRAKE ROTORS

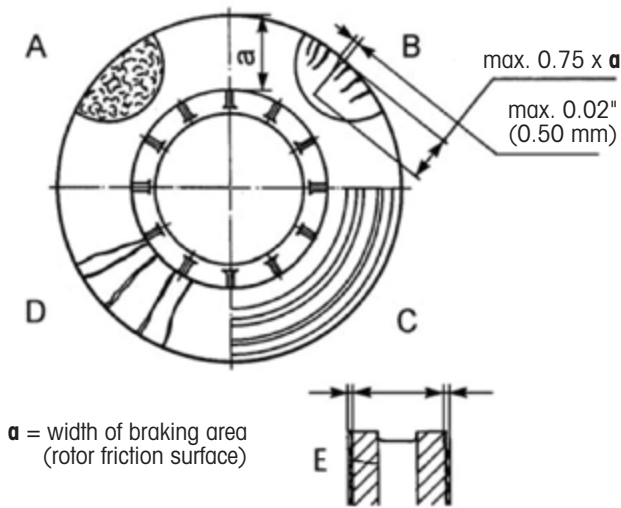

Figure 11: Rotor condition analysis

Permissible

- A Web-like crack formation
- B Radial cracks up to max. 0.02" (0.5 mm) width
- C Unevenness of the rotor friction surface up to max. 0.06" (1.5 mm) depth

Not Permissible

- D Continuous cracks
 - E A crack that passes completely through the rotor friction surface to the center vent from either side
2. **Check** the brake rotor for cracks and the condition of the friction surface (Figure 11).
 3. **Replace** the brake rotor if a "not permissible" condition exists.

NOTE: If the rotor needs to be replaced, the hub must be removed. Refer to the applicable wheel end maintenance manual, listed in Table 1 on page 6, for this procedure.

CHECKING THE RUNOUT OF THE BRAKE ROTORS

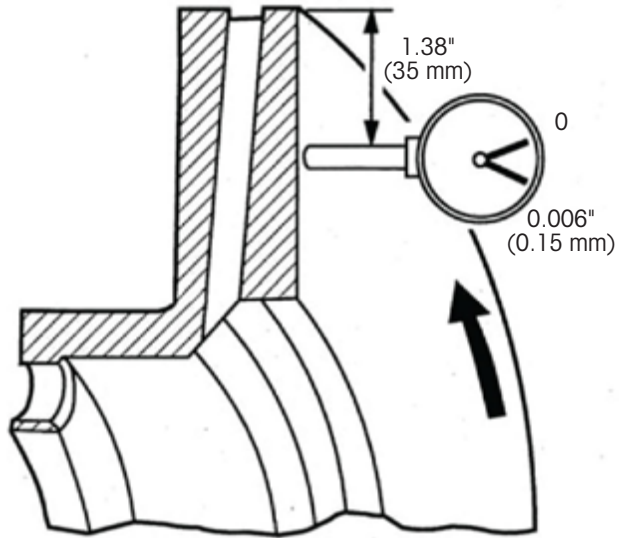

Figure 12: Checking rotor runout

1. **Fasten** the dial indicator to the brake caliper.
2. With the brake rotor installed, **check** the runout by rotating the wheel hub. Limit value: 0.006" (0.15 mm).

IMPORTANT: Only install cleaned and grease-free brake rotors.

3. **Replace** the brake rotor or have it properly resurfaced if the brake rotor runout is more than 0.006" (0.15 mm). Also replace if, after resurfacing, the thickness is below minimum (Figure 10 on page 12).
4. **Install** the brake pads. Refer to INSTALLING BRAKE PADS on page 18.



CHECKING GUIDE PIN BEARING PLAY

⚠CAUTION: Gripping brake from inside may cause injuries, GRIP BRAKE FROM FAR OUTSIDE EDGES.

1. **Remove** the vehicle wheel in accordance with the instructions of the axle and/or vehicle manufacturer.
2. **Remove** the brake pads and the pressure plate. Refer to [REMOVING THE BRAKE PADS](#) on page 14.
3. **Manually push** the brake caliper completely outboard.
4. **Fasten** the magnetic dial indicator support to the brake carrier or the axle ([Figure 14](#)).



Measuring point

Figure 13: *Bearing measuring point, outboard side*

5. **Clean** the measuring point ([Figure 13](#)).

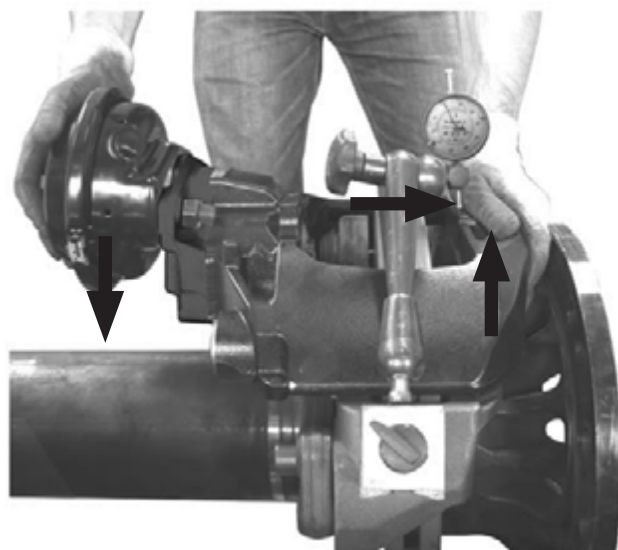

Figure 14: *Tilting brake chamber to axle*

6. **Press** the dial indicator against the measuring point on the brake caliper ([Figure 14](#)).
7. Applying force to **tilt** the brake caliper as far as possible toward the axle, as illustrated above, and set the dial indicator to zero.

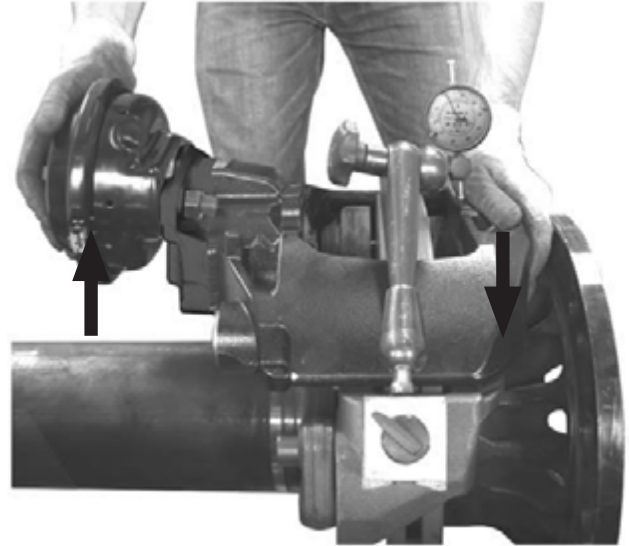

Figure 15: *Tilting brake chamber away from axle*

8. Apply force to **tilt** the brake caliper as far as possible in the opposite direction ([Figure 15](#)).
9. **Read** the dial indicator. The bearing play must not be greater than 0.08" (2 mm).
10. **Replace** the guide pin bushings if the measured bearing play is greater than 0.08" (>2 mm). Refer to [REPLACING GUIDE PIN BOOTS AND BUSHINGS](#) on page 25.
11. **Remove** the dial indicator.
12. **Install** pressure plate, brake pads and adjust the clearance. Refer to [INSTALLING BRAKE PADS](#) on page 18.
13. **Mount** wheels in accordance with the instructions of the axle or vehicle manufacturer.



REPLACING ADB COMPONENTS

NOTE: It is not necessary to remove the brake to replace brake pads. Removal of brake and separation of caliper from carrier is necessary, as defined by the following procedures.

REPLACING THE BRAKE PADS

IMPORTANT: Observe all safety instructions. Refer to IMPORTANT SAFETY NOTICES on page 3. These instructions must be observed to avoid personal injury and/or material damage.

⚠CAUTION: **Gripping brake from inside may cause injuries, GRIP BRAKE FROM FAR OUTSIDE EDGES.**

REMOVING THE BRAKE PADS

IMPORTANT: The brake chamber does not need to be removed in order to replace the brake pads. The brake is shown without the brake chamber for illustration purposes only.

Always replace the brake pads by axle and use a new retaining system for brake pads and pressure plates. Retainer springs are already pre-assembled on the brake pads.

NOTICE: **The 8 mm adjuster components can be damaged if using open-ended wrenches or power tools.**

Only use tools listed in ADB TOOLS on page 37 and described in these procedures.

1. **Remove** the vehicle wheel in accordance with the instructions of the axle or vehicle manufacturer.

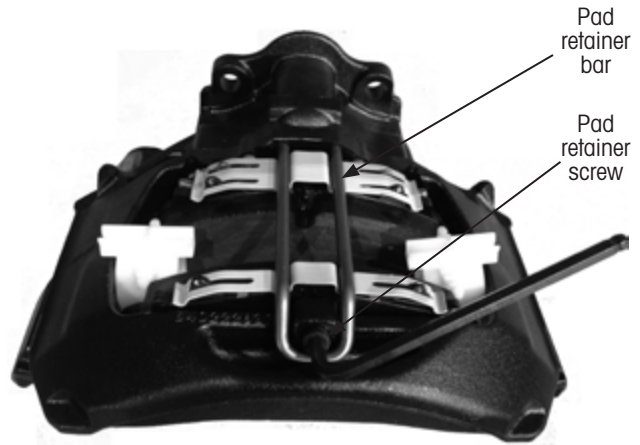

Figure 16: Removing pad retainer screw

2. **Loosen** the pad retainer screw from the brake caliper (Figure 16). Refer to APPENDIX A: WRENCH SIZE AND TIGHTENING TORQUES on page 36, Item II. Apply slight pressure on the pad retainer bar with your hand at the same time.



Figure 17: Loose pad retainer bar, prior to removal

3. **Completely remove** the pad retainer bar from the brake caliper.

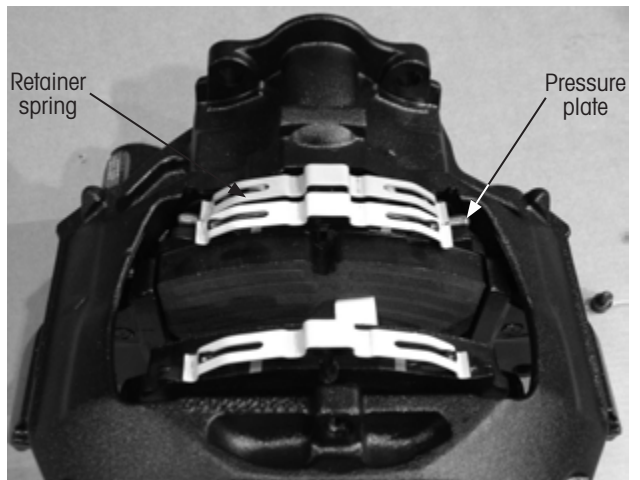

Figure 18: Retainer spring, pad retainer bar removed



4. **Remove** the retainer spring from the pressure plate (Figure 18).

IMPORTANT: Brake pad retainer springs are pre-attached. **DO NOT REMOVE.**

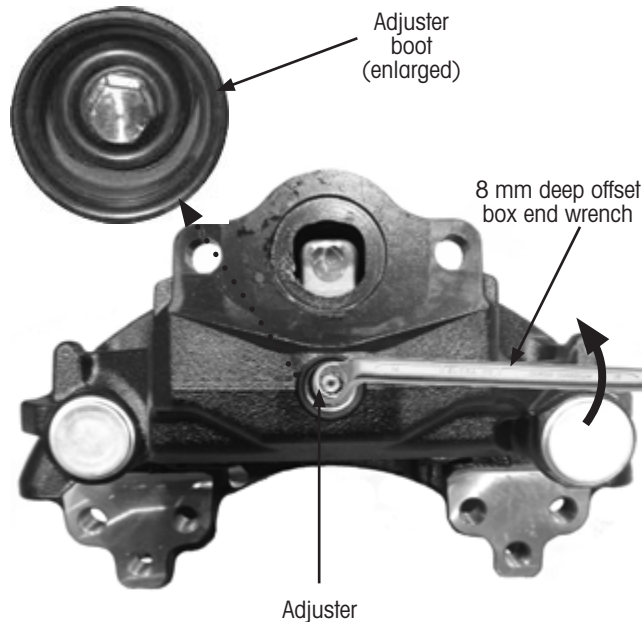

Figure 19: Rotating adjuster with an 8 mm deep offset box end wrench

5. **Carefully remove** the adjuster plug from the caliper. Refer to Figure 5 on page 9 for proper tool and removal procedure.

NOTICE: Damage can occur at the inner seal when the tool is improperly positioned between brake caliper and outer side of the adjuster boot.

6. **Check** the adjuster boot for wear and damage (Figure 19). Replace if damaged or worn.
7. To prevent rotation of the adjuster piston, use your hand to **push** the pressure plate towards the inboard side, with the adjuster piston pin in the pressure plate slot.

NOTICE: Damage can occur to the adjuster boot if the adjuster piston is allowed to rotate.

8. Use the 8 mm deep offset box end wrench to **turn** the adjuster counterclockwise as far as it will go. Then **turn** the adjuster clockwise approximately 90°.
9. **Check** adjuster boot for wear and damage. Replace if damaged or worn.

⚠WARNING: Never apply brake when pads are removed. Applying the brake with no brake pads can cause personal injury or may damage the brake.

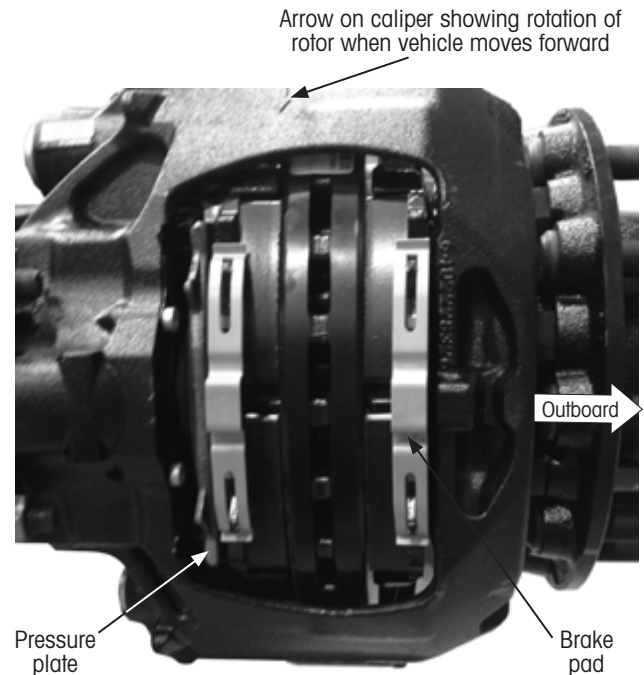

Figure 20: Removing outboard brake pad

10. **Manually push** the brake caliper outboard and remove the outboard brake pad (Figure 20).

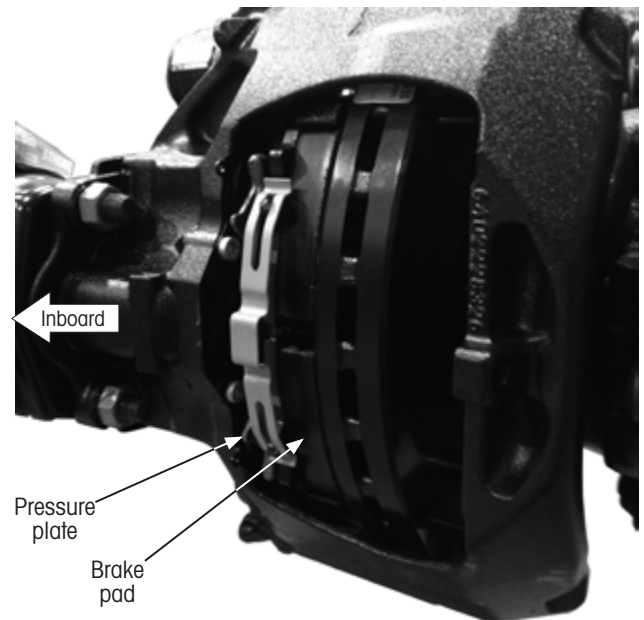

Figure 21: Removing inboard brake pad and pressure plate

11. **Manually push** the brake caliper inboard (Figure 21, arrow).
12. **Remove** the inboard brake pad.



13. **Remove** the pressure plate from the brake caliper.
14. **Check** the pressure plate for excessive corrosion and damage. Replace if corroded or damaged.

NOTE: If replaced, the pressure plate must always be replaced by axle.

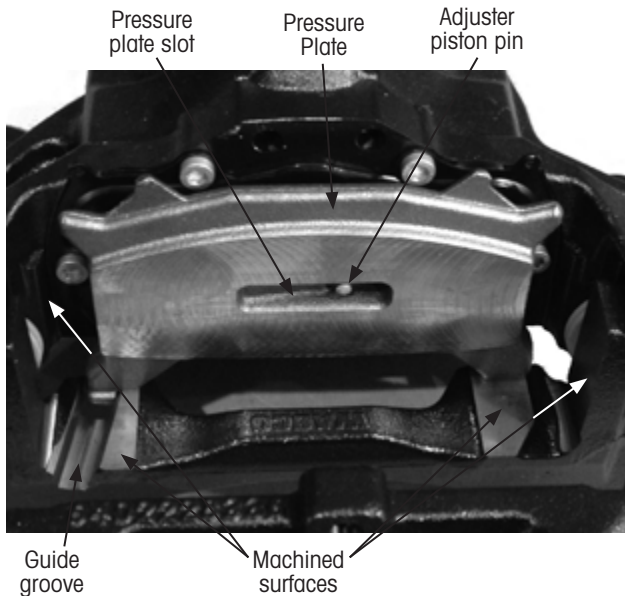

Figure 22: *Cleaning slots and pressure plate guides*

15. Use a wire brush to **clean** pressure plate, guide groove on caliper and pressure plate and all machined surfaces on the brake caliper. Remove any corrosion.

IMPORTANT: The machined surfaces of the brake caliper must be clean and free of grease!

NOTICE: **Inappropriate cleaning may result in damage to the protection boots** (Figure 24 on page 17). This must be avoided.

CHECKING BRAKE CALIPER MOVEMENT



Caliper fully outboard

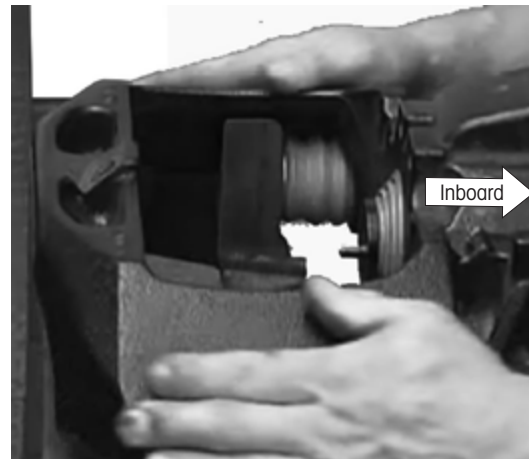

Caliper fully inboard

Figure 23: *Checking caliper movement*

1. **Manually slide** the brake caliper across the entire stroke of the guide pins several times and check for ease of movement (Figure 23).

NOTICE: **While moving the caliper, ensure the guide pin boots are not pinched against the brake carrier.**

2. If the caliper does not move easily, **replace** the bushings, guide pins and guide pin boots. Refer to REPLACING GUIDE PIN BOOTS AND BUSHINGS on page 25.

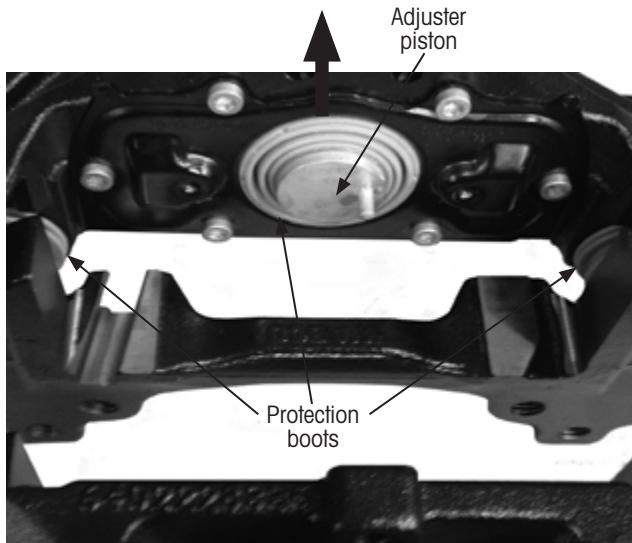

Figure 24: Pushing caliper toward inboard side

3. **Manually push** the brake caliper inboard.
4. **Carefully wipe clean** all protection boots.
5. **Check** the protection boots (Figure 24 through Figure 28) for wear and damage.
6. **Replace** any damaged or worn protection boots. Refer to REPLACING PROTECTION BOOTS on page 24.



Figure 25: Improperly seated guide pin boot



Figure 26: Twisted guide pin boot



Figure 27: Adjuster piston boot damage

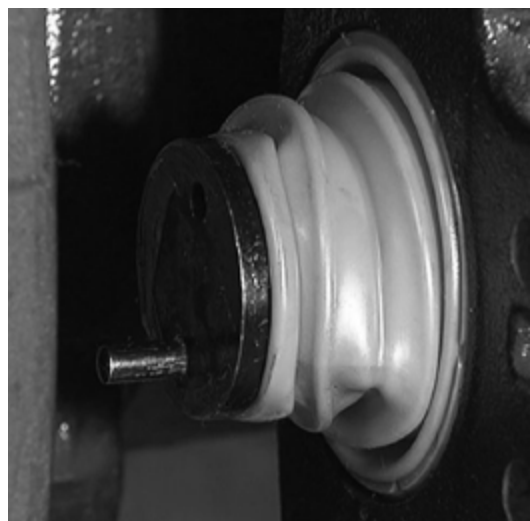

Figure 28: Wrinkled adjuster piston boot



CHECKING THE ADJUSTER UNIT (CLAMPING UNIT)

NOTICE: The 8 mm adjuster components can be damaged if using open-ended wrenches or power tools.

Only use tools listed in ADB TOOLS on page 37 and described in these procedures.

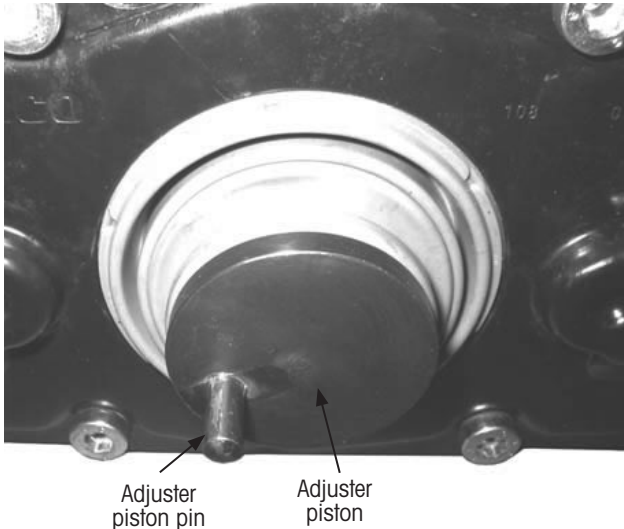

Figure 29: Adjuster piston rotation with pin

1. While checking the adjuster, **restrain** the adjuster piston pin to prevent rotation and damage to the adjuster piston boot (Figure 29).

NOTE: This can be accomplished by temporarily installing the pressure plate, as defined on right.

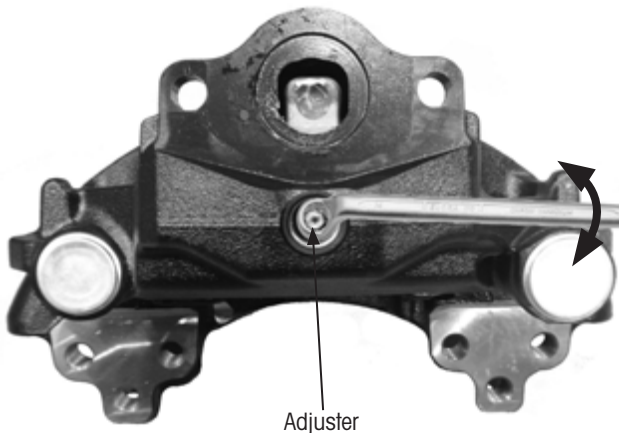

Figure 30: Checking adjuster movement

2. Use the 8 mm deep offset box end wrench to **turn** the adjuster clockwise towards the brake rotor (Figure 30). **Check** for ease of movement when doing this.

3. Following the test, **rotate** the adjuster piston clockwise up to the stop position and back again.

NOTE: It is normal for the resistance to be greater when turning the adjuster to move the adjuster piston out towards the rotor.

4. **Check** the adjuster, if necessary. Refer to CHECKING ADJUSTER OPERATION on page 9.

INSTALLING BRAKE PADS

NOTICE: The 8 mm adjuster components can be damaged if using open-ended wrenches or power tools.

Only use tools listed in ADB TOOLS on page 37 and described in these procedures.

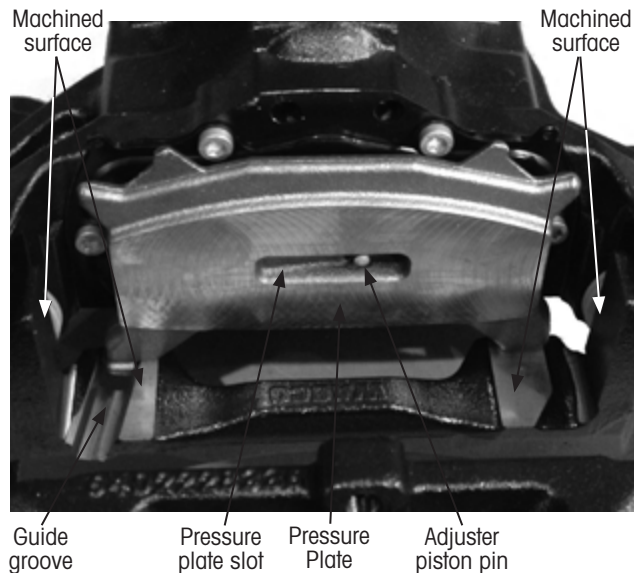

Figure 31: Installing pressure plate

NOTICE: The pressure plate (Figure 31) must always be placed correctly in the guide groove and is to entirely cover machined surfaces shown in (Figure 31). Otherwise the pressure plate could slide out of position.

1. **Manually move** the brake caliper inboard until there is sufficient clearance to insert the pressure plate.
2. **Insert** the pressure plate into the brake caliper (Figure 31).
3. **Slide** the pressure plate up against the adjuster piston with the adjuster piston pin fitting into the pressure plate slot.



NOTE: It may be necessary to move the brake caliper and/or rotate the adjuster piston until the pin engages the slot of the pressure plate.

4. **Ensure** the adjuster piston boot is not twisted (Figure 28 on page 17).

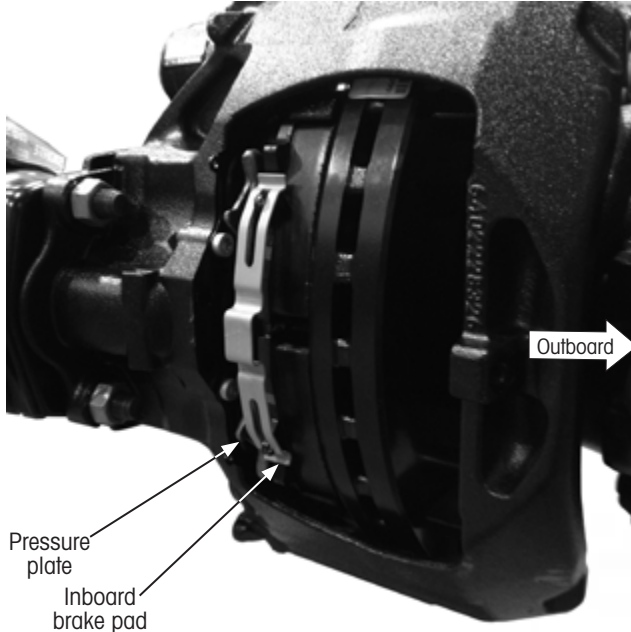

Figure 32: Inserting new brake pad, inboard

5. **Insert** the inboard brake pad (Figure 32).
6. **Manually push** the brake caliper outboard until the inboard brake pad contacts the rotor (Figure 32).
7. **Insert** the brake pad on the outboard side.

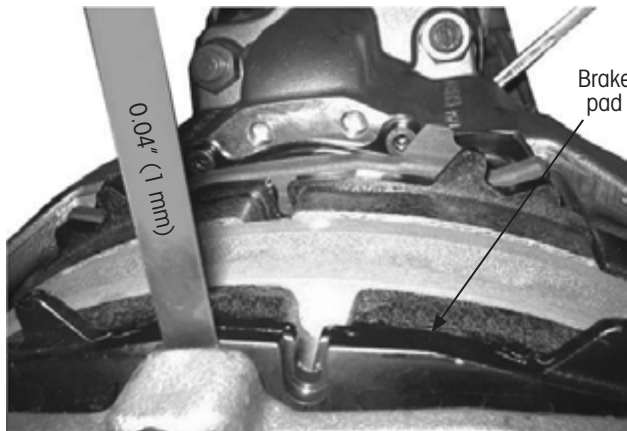

Figure 33: Checking brake pad clearance

8. **Measure and adjust** the clearance using a 0.04" (1 mm) feeler gauge (Figure 33):
 - A. **Insert** the feeler gauge between the outboard brake pad and the brake caliper as shown in Figure 33.

- B. **Turn** the adjuster counterclockwise with an 8 mm deep offset box end wrench until both brake pads contact the brake rotor.
- C. **Remove** the feeler gauge.

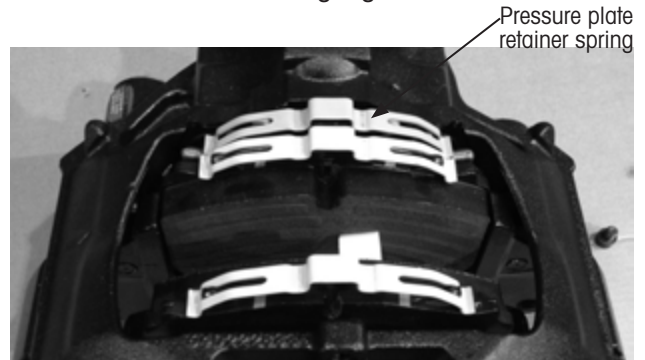

Figure 34: Installing pressure plate retainer spring

9. **Place** a new retainer spring onto the pressure plate (Figure 34).

IMPORTANT: Brake pad retainer springs are pre-attached. **DO NOT REMOVE.**



Figure 35: Installing pad retainer bar

10. **Insert** the pad retainer bar into the holes of brake caliper (Figure 35, arrows).
11. Push the pad retainer bar fully into the holes while pushing downward so the retainer springs are engaged into the bar and there is sufficient clearance to install the pad retainer bar screw (Figure 36).



Figure 36: Securing pad retainer bar with pad retainer screw

12. **Fasten** the new pad retainer screw to the brake caliper with the specified torque (Figure 36). Refer to APPENDIX A: WRENCH SIZE AND TIGHTENING TORQUES on page 36, item II.

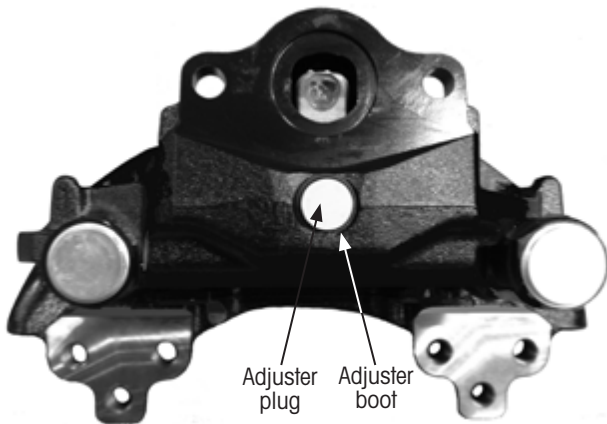

Figure 37: Inserting adjuster plug

13. **Push** a new adjuster plug into the adjuster boot (Figure 37). Ensure the plug has a tight seat.

NOTE: If more repairs are to be performed, proceed to next or previous procedure.

14. **Manually rotate** hub to check for ease of movement.
15. **Mount** wheels in accordance with the instructions of the axle or vehicle manufacturer.

REPLACING THE BRAKE

⚠CAUTION: Observe all safety instructions. Refer to **IMPORTANT SAFETY NOTICES** on page 3. These instructions must be observed to avoid personal injury and/or material damage.

IMPORTANT: The brake must be removed to service the hub or rotor. Refer to Table 1 on page 6 for a list of applicable Hendrickson wheel-end maintenance manuals.

NOTE: Illustrations are for example only and may deviate from the actual design of the brake.

REMOVING THE BRAKE

1. **Remove** the vehicle wheel in accordance with the instructions of the axle or vehicle manufacturer.
2. **Remove** the brake chamber from the brake caliper. Refer to REPLACING THE BRAKE CHAMBER on page 22.
3. **Remove** the brake pads. Refer to REMOVING THE BRAKE PADS on page 14.

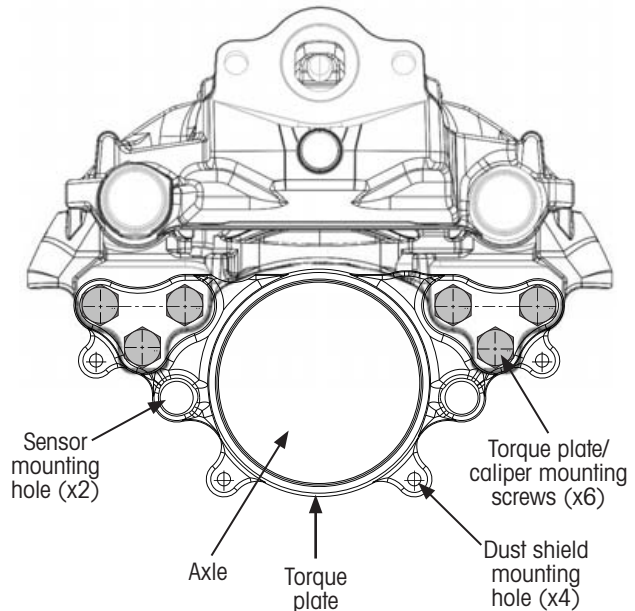

Figure 38: Disc Brake mounted to torque plate.

4. **Remove** torque plate mounting screws (Figure 38).
5. **Remove** the brake caliper with brake carrier from the axle. Refer to APPENDIX A: WRENCH SIZE AND TIGHTENING TORQUES on page 36, item III.



6. **Check** the brake rotor. Refer to INSPECTING THE BRAKE ROTOR on page 11.
7. **Check** the brake pads and replace if necessary. Refer to MANUALLY MEASURING BRAKE PAD WEAR on page 11.
8. **Check** the torque plate on the axle for wear and damage.
9. **Clean** the torque plate on the axle and remove any dirt, rust and grease.

INSTALLING THE BRAKE

If following this procedure to reinstall original brake after servicing, skip to Step 2.

IMPORTANT: Brake pads, pressure plate and brake chamber are **not provided** with an aftermarket brake.

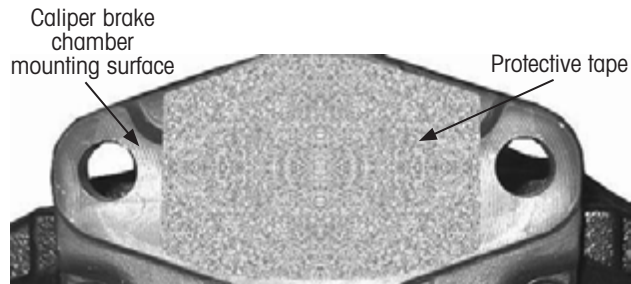

Figure 39: New caliper with protective tape

NOTE: The protective tape covering the caliper brake chamber mounting surface must be fully removed (Figure 39).

1. **Remove** all shipping material from the new brake (Figure 39).
2. **Check** the connecting surface on the axle torque plate and the brake carrier. **Remove** any dirt, rust or oil.

IMPORTANT: The MAXX22T™ torque plate is designed to prevent mixing of left and right brakes. An arrow painted on or cast in the brake caliper indicates the brake rotor's direction of rotation moving forward.



Figure 40: Positioning caliper over brake rotor

3. **Place** the brake assembly, with brake carrier, on top of the brake rotor and mount the brake onto the axle.
 4. **Tighten** the screws (Figure 38) according to specifications in T71004 ADB Rotor (U-shape style) and Caliper Mounting or APPENDIX A: WRENCH SIZE AND TIGHTENING TORQUES on page 36, item III.
 5. **Install** brake pads. Refer to INSTALLING BRAKE PADS on page 18.
 6. **Mount** the brake chamber on the caliper. Refer to INSTALLING THE BRAKE CHAMBER on page 22.
- NOTE:** If more repairs are to be performed, proceed to next or previous procedure.
7. **Manually rotate** hub to check for ease of movement.
 8. **Mount** wheels in accordance with the instructions of the axle or vehicle manufacturer.



REPLACING THE BRAKE CHAMBER

⚠WARNING: a damaged brake chamber can result in serious or fatal injury during handling and use.

⚠WARNING: A damaged brake chamber can cause the brake system to not operate properly.

⚠CAUTION: Observe all safety instructions. Refer to **IMPORTANT SAFETY NOTICES** on page 3. These instructions must be observed to avoid personal injury and/or material damage.

Only use brake chambers as specified by the axle or brake manufacturer.

Pay attention to and strictly adhere to brake chamber manufacturer installation specifications, testing and installation instructions.

The illustrations are for example only and may deviate from the actual design.

REMOVING THE BRAKE CHAMBER

⚠CAUTION: Make sure air connection lines have been removed before removing brake chamber. To avoid injury and damage to brake components, manually cage the brake chamber prior to servicing brake.

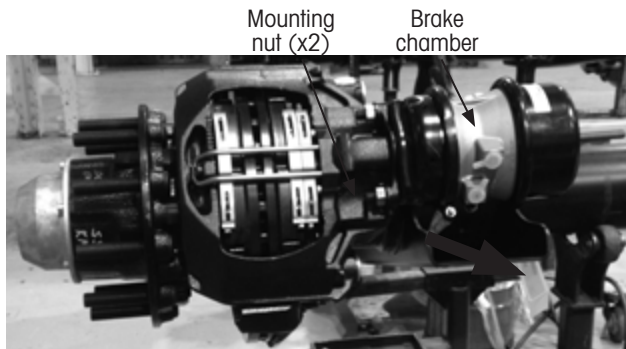

Figure 41: Removing brake chamber

1. **Unscrew** the air connection from the brake chamber according to the manufacturer's specifications.

2. **Manually cage** the brake chamber according to brake chamber manufacturer's procedures.
3. **Unscrew** the brake chamber nuts. Refer to **APPENDIX A: WRENCH SIZE AND TIGHTENING TORQUES** on page 36, item V.

NOTICE: Ensure no dirt or moisture enters the brake when removing the brake chamber.

4. **Remove** the brake chamber from the brake caliper.

INSTALLING THE BRAKE CHAMBER

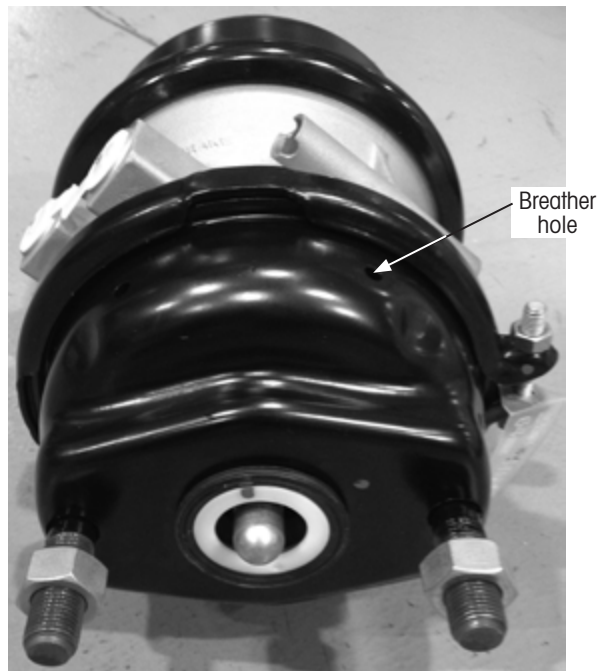

Figure 42: Sample ADB brake chamber

NOTICE: Must be installed with breather hole open at bottom most position (Figure 42).

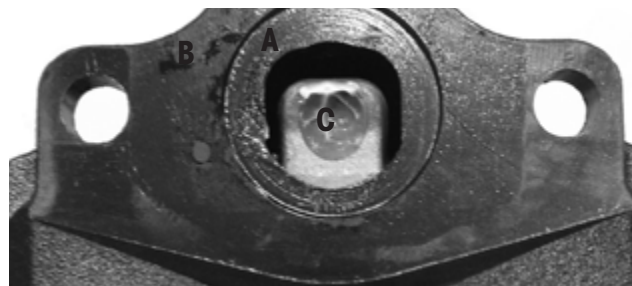

Figure 43: Caliper brake chamber mounting surfaces

1. If not previously caged, **manually cage** the brake chamber according to brake chamber manufacturer's procedures.



2. **Clean** the brake caliper boot surface (Figure 43, A) and flange area (Figure 43, B).

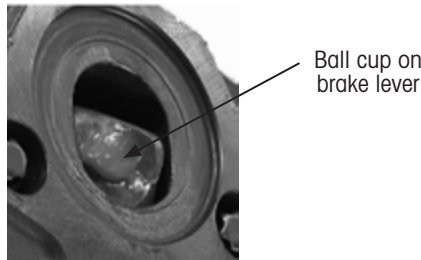

Figure 44: Greased ball cup

3. Before attaching the brake chamber, **grease** the ball cup in the brake lever (Figure 44).

NOTICE: Damage to the brake lines can occur if installed incorrectly or becomes bent or rubs up against other parts.

Installed brake lines should be free of twists and chaffing or rubbing against any other components.



Figure 45: Brake chamber piston-rod seal

4. **Inspect** the brake chamber for damage, particularly at the inner area of the piston-rod seal (Figure 45).

⚠WARNING: a damaged brake chamber can result in serious or fatal injury during handling and use.

⚠WARNING: A damaged brake chamber can cause the brake system to not operate properly.

5. **If damaged, replace** the brake chamber.

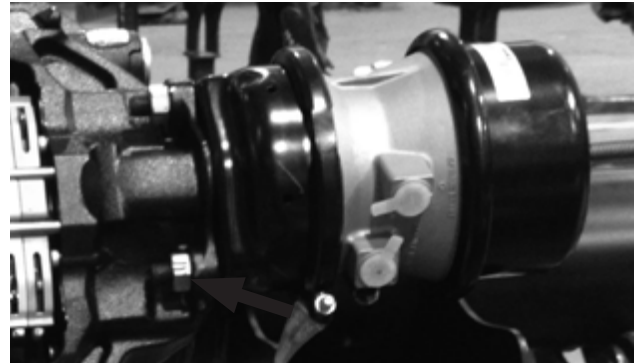
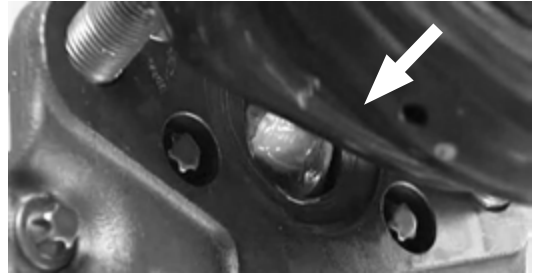

Figure 46: Installing brake chamber

6. **Place** the brake chamber onto the brake caliper (Figure 46).
7. Use a wrench to **screw** new fastening nuts onto the brake chamber until the brake chamber fully rests on the brake caliper. Refer to APPENDIX A: WRENCH SIZE AND TIGHTENING TORQUES on page 36, item V.
8. **Torque** nuts to specifications. **It is essential to observe the instructions.**
9. **Attach** the brake hose to the brake chamber according to the chamber manufacturer's specifications.
10. **Ensure** enough slack is added to the brake hose to prevent stress. Also, secure brake hoses to avoid obstruction of brake caliper movement over its entire stroke.
11. **Check** the air connection for tightness according to the chamber manufacturer's specifications.
12. **Follow** brake chamber manufacturer's procedures to manually uncage the brake chamber.



REPLACING PROTECTION BOOTS

Procedures in this section define how to service the brake caliper and its components.

⚠CAUTION: Observe all safety instructions. Refer to **IMPORTANT SAFETY NOTICES** on page 3. These instructions must be observed to avoid personal injury and/or material damage.

NOTE: If all protection boots are to be replaced, the work sequences for replacing the guide pin boots and bushings, as well as the adjuster piston boot can be performed together.

Illustrations are for example only and may deviate from the actual design.

IMPORTANT: If only replacing the adjuster piston boot or adjuster boot, brake caliper and brake chamber need not be separated.

SUMMARY OF PROCEDURES

Procedures for removing and installing brake prior to servicing the caliper are defined prior to this section as indicated below:

REMOVING THE BRAKE PADS on page 14

REMOVING THE BRAKE CHAMBER on page 22

REMOVING THE BRAKE on page 20

REMOVING BRAKE CALIPER FROM BRAKE CARRIER on page 24

REPLACING GUIDE PIN BOOTS AND BUSHINGS on page 25, if required

REPLACING ADJUSTER PISTON BOOT on page 30, if required

REPLACING ADJUSTER BOOT on page 32, if required

MOUNTING BRAKE CALIPER TO BRAKE CARRIER on page 28

INSTALLING THE BRAKE on page 21

INSTALLING BRAKE PADS on page 18

INSTALLING THE BRAKE CHAMBER on page 22

REMOVING BRAKE CALIPER FROM BRAKE CARRIER

1. **Remove** the brake. Refer to REMOVING THE BRAKE on page 20.

⚠CAUTION: Once you have released the brake caliper, there is a risk of pinching your fingers. Make sure your hands & fingers are not in the way.

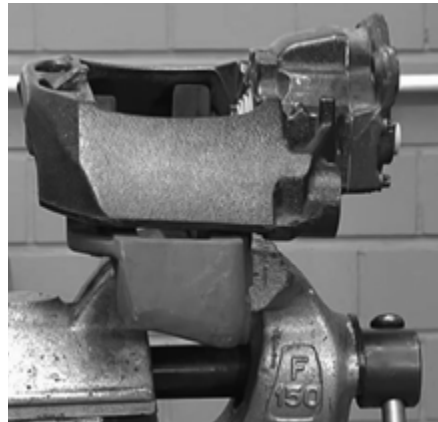

Figure 47: Brake mounted in vice

2. **Use** a suitable device to hold brake while servicing the brake assembly (Figure 47).

NOTE: Refer to APPENDIX B: ADB TOOLS on page 37 for tool information.

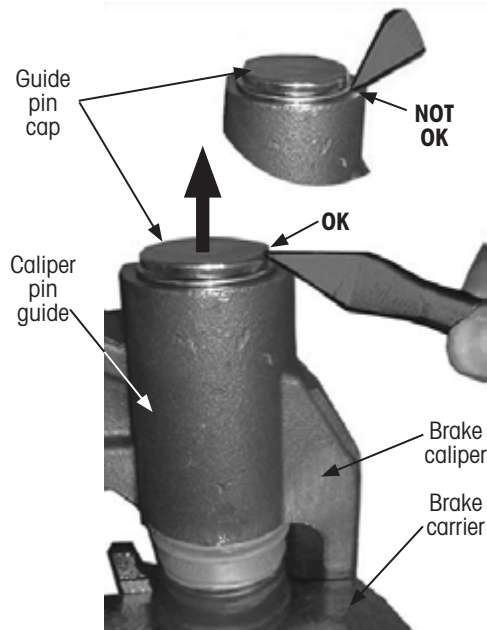

Figure 48: Removing guide pin caps



NOTICE: Damage to the bores may occur if tools are used incorrectly (Figure 48). Do not place tool (e.g. chisel or screwdriver) on caliper face. Only position the tool on the guide pin cap.

3. **Remove** the guide pin caps (Figure 48).

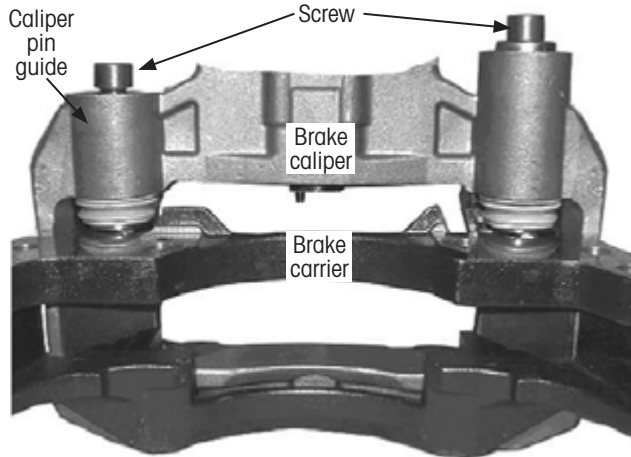

Figure 49: Removing guide pin screws

4. **Remove** guide pin screws (Figure 49). Refer to APPENDIX A: WRENCH SIZE AND TIGHTENING TORQUES on page 36, item IV.



Figure 50: Supporting caliper while removing screws

CAUTION: Properly support the caliper while removing guide pin screws. Once the screws are removed, the caliper is loose from the carrier and may fall if not supported.

5. **Separate** the brake caliper from the brake carrier.

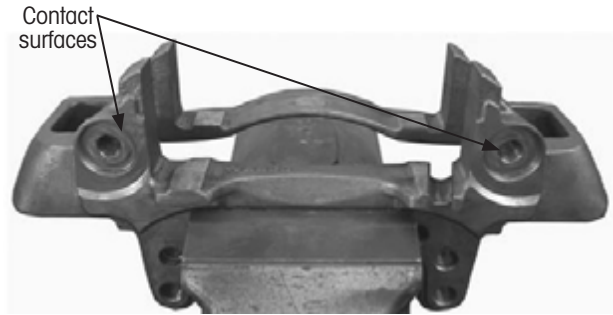

Figure 51: Guide pin contact surfaces

6. **Clean** guide pin contact surfaces on the brake carrier.

REPLACING GUIDE PIN BOOTS AND BUSHINGS

If not required, skip to REPLACING ADJUSTER PISTON BOOT on page 30.

IMPORTANT: Only use the correct tools for these procedures. Refer to the tables in APPENDIX B: ADB TOOLS on page 37.

Guide Pin Disassembly

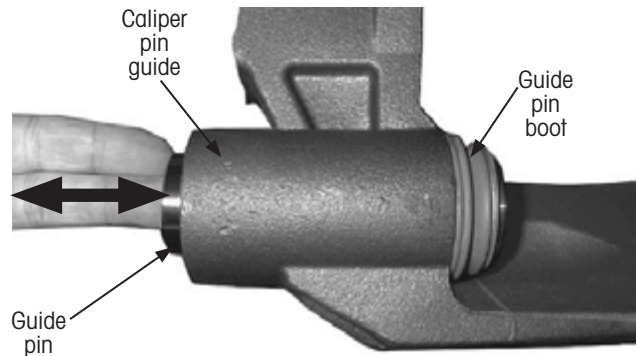

Figure 52: Removing guide pins

1. **Remove** the guide pins from the brake caliper (Figure 52).
2. **Pull** the guide pin boot out of the boot seat of the brake caliper.

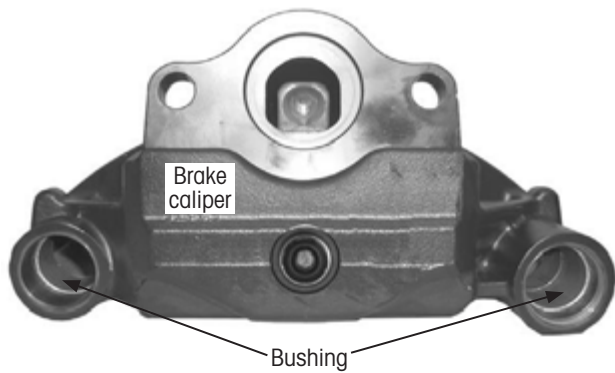

Figure 53: Caliper rear view

3. **Place** the brake caliper on a firm base for pressing out the bushings (Figure 53). The back of the brake caliper must face upwards.

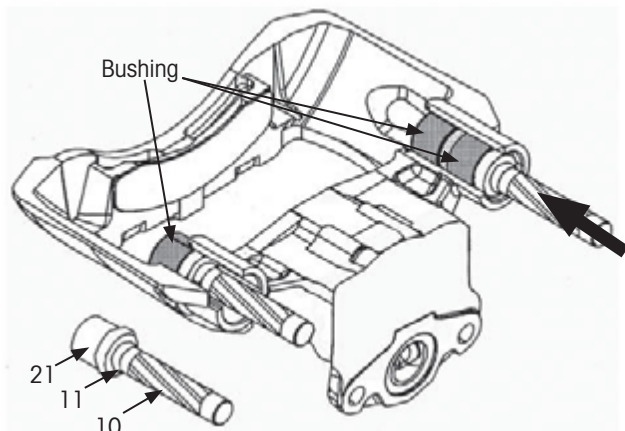

Figure 54: Removing caliper guide pin bushings

4. Assemble and use 10, 11 and 21 to press the bushings out of the brake caliper (Figure 54).
5. **Thoroughly clean** the bores in the caliper.

Guide Pin Assembly

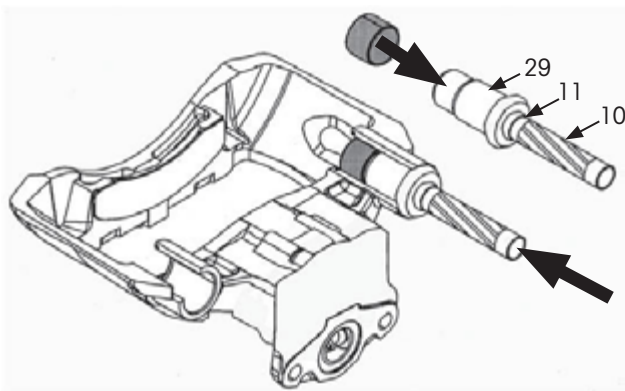

Figure 55: Inserting long guide inner bushing

1. **Press** in two new bushings for the long guide pin:

- A. Assemble and use 10, 11 and 29 to press the inner bushing into the bore of the brake caliper until the tool stops (Figure 55).

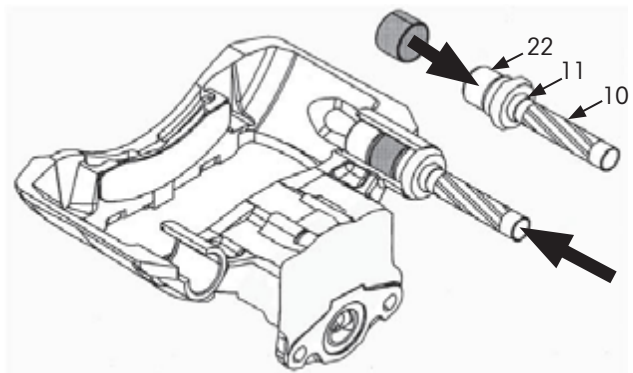

Figure 56: Inserting long guide outer bushing

- B. Assemble and use 10, 11 and 22 to press the outer bushing into the same bore until the tool stops (Figure 56).

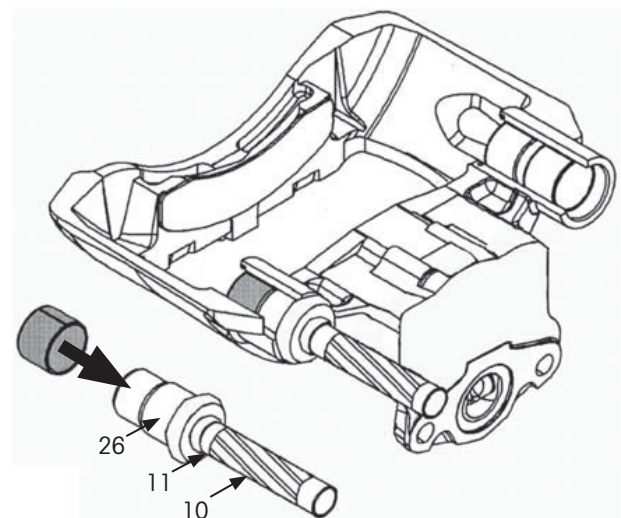

Figure 57: Inserting short guide bushing

2. Assemble and use 10, 11 and 26 to press a new bushing for the short guide pin into the bore of the brake caliper until the tool stops (Figure 57).

NOTE: Grease should be included in parts kit.

3. **Grease** inside sliding surfaces of all bushings and the space between the long guide pin bushings.

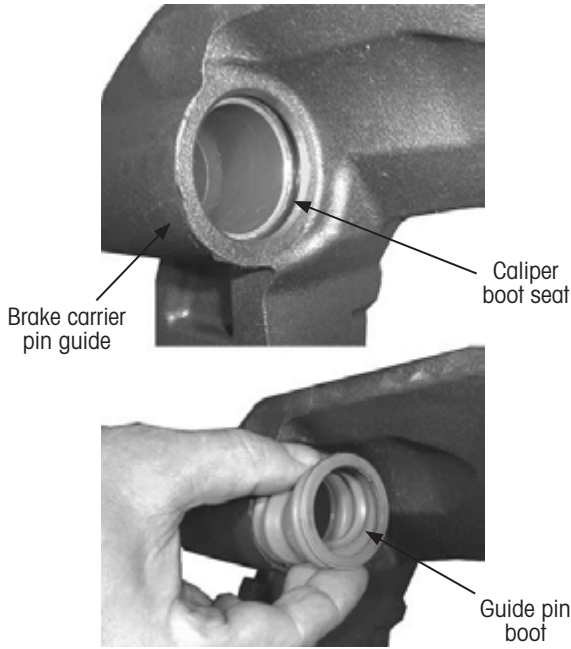

Figure 58: Guide pin boot

IMPORTANT: The guide pin boot seats must be clean and free from grease.

4. **Clean** the guide pin and boot seats of the brake caliper (Figure 58).
5. **Manually push** two new guide pin boots into the brake caliper boot seats (Figure 58).

IMPORTANT: Make sure the guide pin boots are seated and wrinkle-free (Figure 25 on page 17).

6. **Grease** the bearing surfaces of the guide pins and the exposed edge of the guide pin boots.



Figure 59: Inserting guide pin

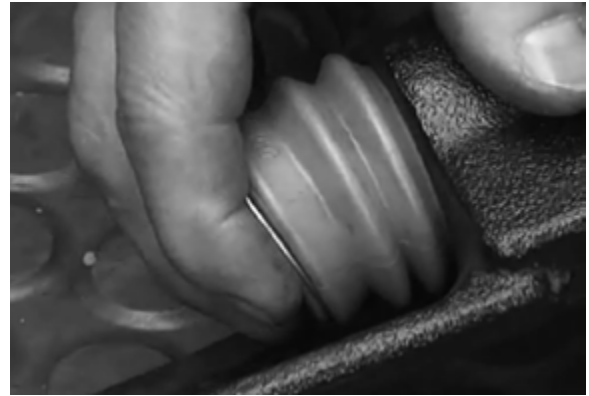

Figure 60: Seating of guide pin boot on guide pin

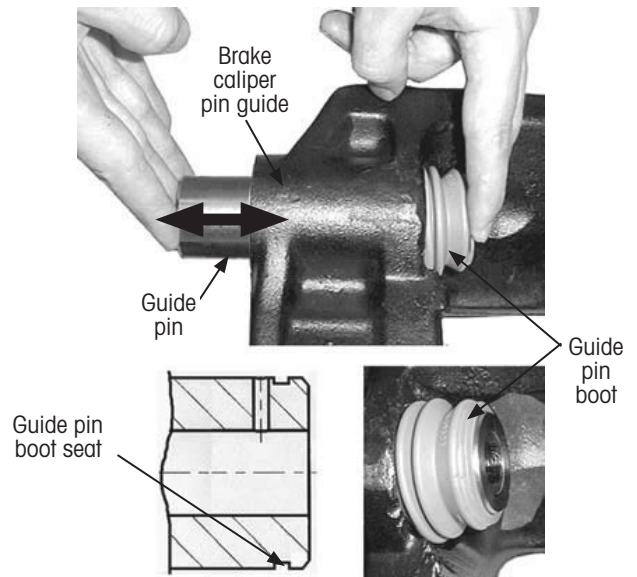

Figure 61: Inserting guide pin

7. **Insert** the two new guide pins into the brake caliper from the inboard side (Figure 59, Figure 60 and Figure 61).
8. **Slide** the guide pin boots over the guide pins (Figure 60).

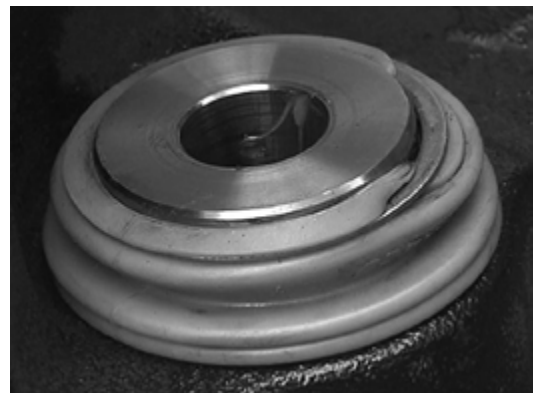

Figure 62: Improper seating of guide pin boot on guide pin

IMPORTANT: Make sure the metal ring does not come off the guide pin boot in the process (Figure 62).

9. **Position** the exposed edge of the guide pin boots into the boot seats of the guide pins (Figure 61).
10. **Ensure** the exposed edge of the guide pin boots have an even and wrinkle-free seat in the boot seat of the guide pin and brake caliper (Figure 62 and Figure 25 on page 17).



Figure 63: Excessive grease on guide pin and boot

IMPORTANT: The face of the guide pins and the contact areas of the brake carrier must be clean and free of grease (Figure 63).

11. **Remove** any excess grease from guide pin surfaces indicated in Figure 63.

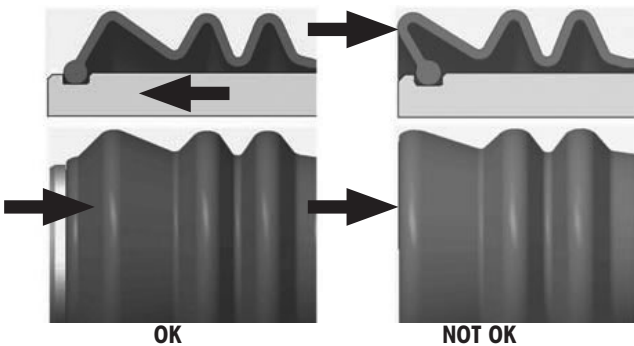

Figure 64: Guide pin boot installation

NOTICE: Damage to guide pin boots may occur if, as shown in Figure 64 (NOT OK), the guide pin boots are allowed to extend past the guide pin face. This can result in unwanted pinching and/or wear of the boot as it contacts the brake carrier.

12. **Manually push** the guide pins out of the brake caliper towards the brake carrier until the leading fold (Figure 64, NOT OK) of the guide pin boot pulls away from the collar (Figure 64, OK).
13. **Manually move** the guide pins in the bushings lightly back and forth and check for ease of movement to ensure guide pins slide freely within the caliper pin guides.

MOUNTING BRAKE CALIPER TO BRAKE CARRIER

NOTE: The carrier should be in the holding device for reassembly (Figure 47 on page 24).

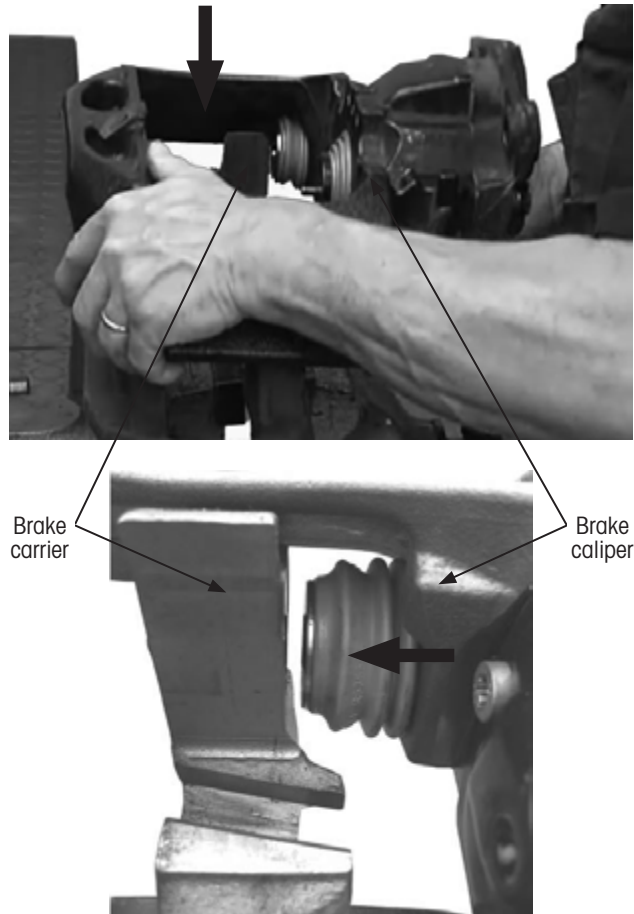

Figure 65: Installing caliper onto brake carrier

1. **Place** the brake caliper on the brake carrier with guide pins aligned to contact surfaces (Figure 65 and Figure 51 on page 25).



Figure 66: Long and short guide pin screws

IMPORTANT: DO NOT add lubricants to screws.

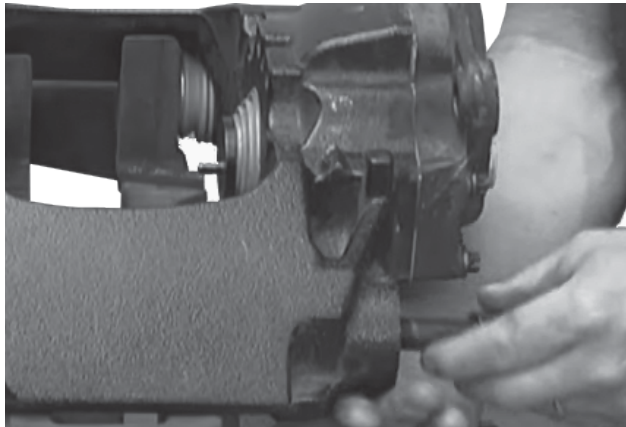

Figure 67: Installing guide pin screws

Always tighten the longer guide pin first, then the shorter guide pin (Figure 67). If the guide pins are removed from the brake carrier during maintenance work, new screws must be used.

NOTICE: During assembly, ensure the guide pin boots are not pinched, damaged or twisted while tightening the screws.

2. **Insert** a new long guide pin screw (Figure 67) through the long guide pin and thread into the brake carrier (Figure 67). **Snug** screw with wrench. Refer to APPENDIX A: WRENCH SIZE AND TIGHTENING TORQUES on page 36, item IV.
3. Repeat Step 2 for the short guide pin screw.
4. **Torque** the screws into the brake carrier (Figure 67); long screw first. Refer to APPENDIX A: WRENCH SIZE AND TIGHTENING TORQUES on page 36, item IV.

5. **Manually slide** the brake caliper across the entire stroke of the guide pins several times and check for ease of movement (Figure 23 on page 16). If movement is rough or strained, review installation procedure and correct the problem.



Figure 68: Greasing bore of guide pin cap

6. **Grease** the bores for the guide pin caps in the brake caliper (Figure 68).

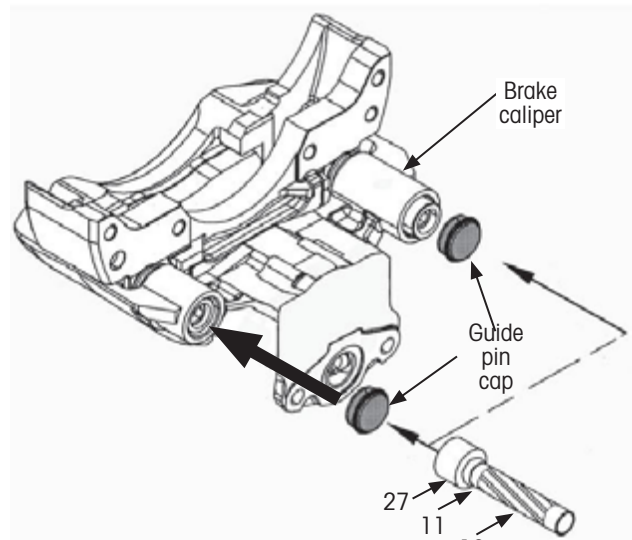

Figure 69: Guide pin cap installation

7. **Manually push** the brake caliper against the brake carrier.
8. **Insert** two new guide pin caps into the bores of the brake caliper (Figure 69).

NOTICE: Damage may occur if improper tools are used (Figure 4 on page 9).



Figure 70: Using tool to install guide pin cap

- Assemble and use tool numbers 10, 11 and 27 (Appendix B) to **press** the guide pin cap down to the stop position (Figure 69 and Figure 70).

REPLACING ADJUSTER PISTON BOOT

If not required, skip to REPLACING ADJUSTER BOOT on page 32.

NOTE: If only replacing the adjuster piston boot or adjuster boot, brake caliper and brake chamber need not be separated.

Removing Adjuster Piston Boot

If not already done so, complete the following procedures:

REMOVING THE BRAKE CHAMBER on page 22

REMOVING THE BRAKE PADS on page 14

REMOVING THE BRAKE on page 20

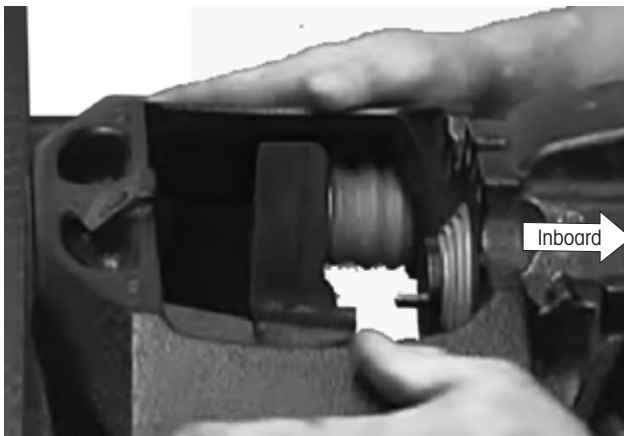

Figure 71: Pushing caliper to inboard side

- Manually push** the caliper completely inboard (Figure 71).

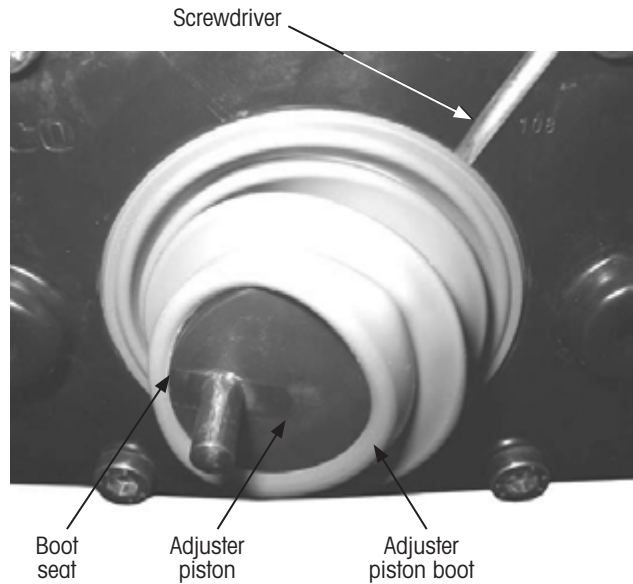

Figure 72: Removing adjuster piston boot

- Pull** the adjuster piston boot from the boot seat of the adjuster piston (Figure 72).

NOTICE: The adjuster piston boot seat may be damaged from incorrect use of the screwdriver or other removal tool.

- Position** the screwdriver between the adjuster piston boot and cover (Figure 72).
- Remove** the adjuster piston boot from the seat of the brake caliper with a screwdriver.
- Check** the thread of the adjuster piston.
- Check** the brake caliper. If dirt or moisture has entered the brake or if the boot seat in the brake caliper is worn or damaged, replace the brake. Refer to REPLACING THE BRAKE on page 20.
- Mark** the position of the pin on the adjuster piston on the brake caliper. The pin must be located in the same position after checking the adjuster piston.

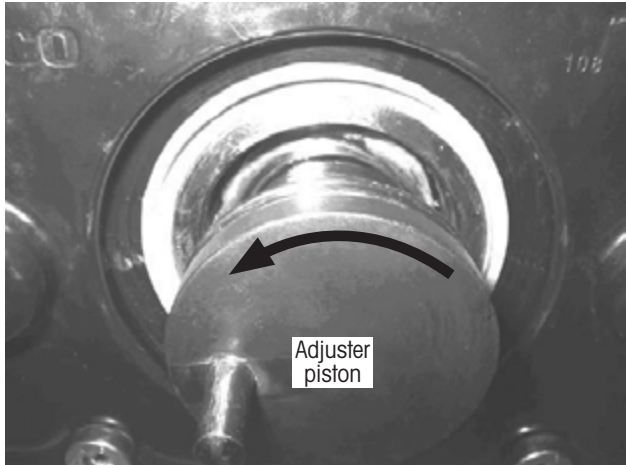

Figure 73: *Rotating adjuster*

8. **Manually turn** adjuster piston counterclockwise about 1.18" (30 mm) out of the brake caliper (Figure 73).



Figure 74: *Corroded adjuster piston*

9. **Check** the thread of the adjuster piston for corrosion, wear and damage (Figure 74).
If the thread and/or visible internal brake parts are worn, damaged or corroded, replace the brake. Refer to REPLACING THE BRAKE on page 20.
10. **Replace** the adjuster piston boot if dirt or water has penetrated into the brake caliper through the boot seat or if the adjuster piston boot has been worn or damaged.
11. **Ensure** the seal is correctly seated in the boot seat of the brake caliper. If necessary, **press** the seal back into the boot seat by hand.

NOTICE: Do not use any sharp edged tools or metal brushes for cleaning. Ensure no dirt or moisture enters the brake when cleaning. The boot seats must be clean and free from grease (Figure 75).

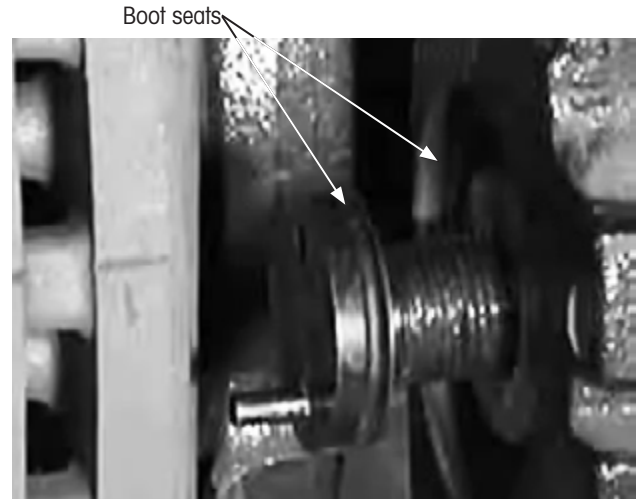

Figure 75: *Clean adjuster piston boot seats*

12. **Clean** the adjuster piston boot seats (Figure 75).

NOTE: Grease should be included in parts kit.

13. **Grease** the thread of the adjuster piston (Figure 75).
14. **Manually turn** the adjuster piston (Figure 75) clockwise back into the brake caliper again. The adjuster piston pin must be in the same position as it was before it was screwed out, refer to Step 7.

Installing Adjuster Piston Boot

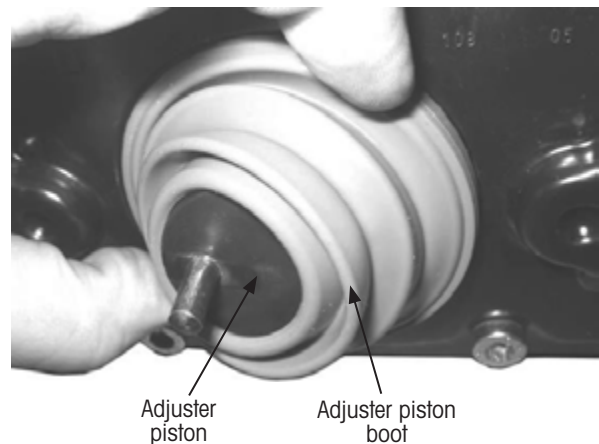

Figure 76: *Installing adjuster piston boot*

1. **Slide** a new and grease-free adjuster piston boot (Figure 76) over the adjuster piston.



2. **Center** the adjuster piston boot and **manually push** it into the boot seat of the brake caliper.

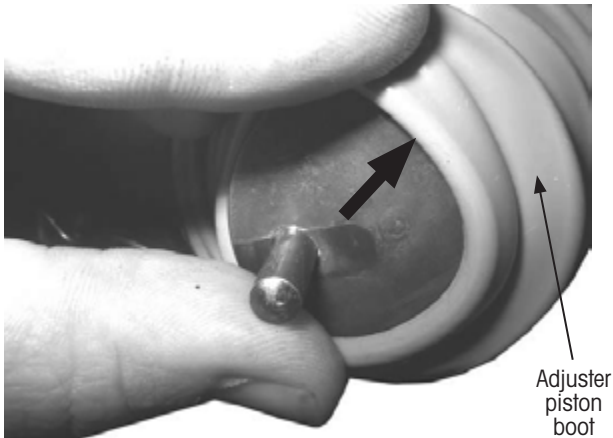

Figure 77: Seating adjuster piston boot edge

3. **Lightly grease** the inner exposed edge of the adjuster piston boot (Figure 77).
4. **Insert** the edge of the adjuster piston boot into the adjuster piston seat (Figure 75 and Figure 77).

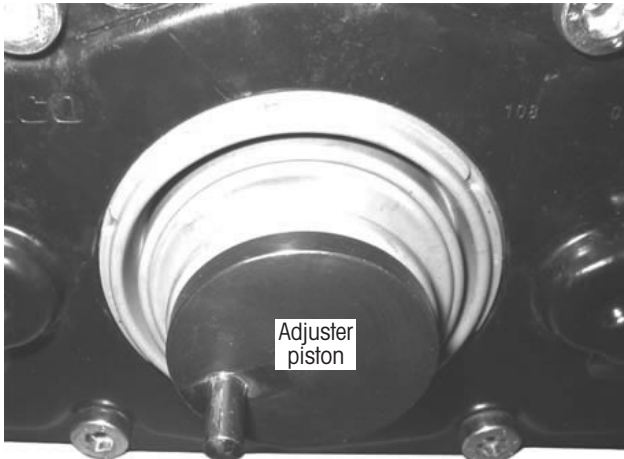

Figure 78: Properly installed adjuster piston boot

5. **Ensure** the adjuster piston boot is correctly seated in the brake caliper and the exposed edge of the adjuster piston boot (Figure 78) is wrinkle-free (Figure 28 on page 17).
6. **Install** the brake pads. Refer to INSTALLING BRAKE PADS on page 18.

If no other brake caliper services is required, perform as needed:

MOUNTING BRAKE CALIPER TO BRAKE CARRIER on page 28

INSTALLING THE BRAKE on page 21

INSTALLING BRAKE PADS on page 18

INSTALLING THE BRAKE CHAMBER on page 22

REPLACING ADJUSTER BOOT

NOTE: If only replacing the adjuster boot, brake caliper and brake chamber need not be removed or separated from the suspension.

Removing Adjuster Boot

If not already done so, perform REMOVING THE BRAKE CHAMBER on page 22.

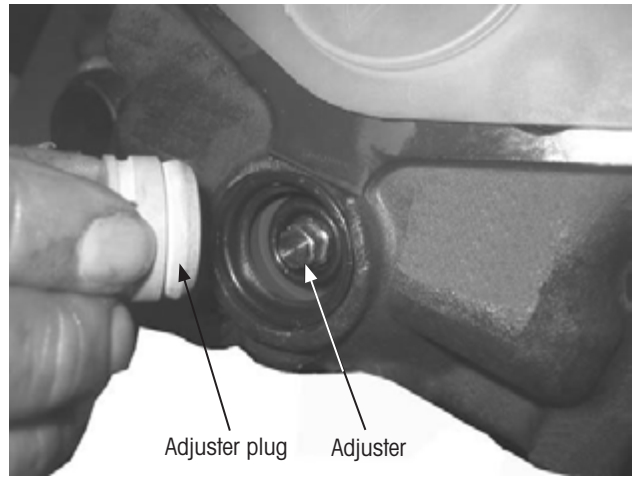

Figure 79: Removing adjuster plug

1. **Remove** the adjuster plug (Figure 79).

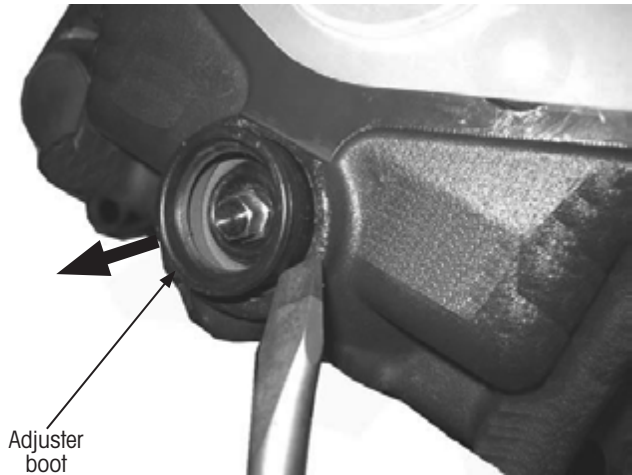

Figure 80: Removing adjuster boot

2. **Use** a suitable tool (e.g. screwdriver) to remove the adjuster boot (Figure 80) out of the brake caliper seat.
3. **Remove** the adjuster boot from the adjuster.

IMPORTANT: Ensure no dirt or moisture enters the brake when cleaning.



Replace the adjuster boot if dirt or water has entered into the brake caliper through the boot seat or if the adjuster boot has been damaged.

If the thread and/or visible internal brake parts are damaged or corroded, replace the brake. Refer to REPLACING THE BRAKE on page 20.

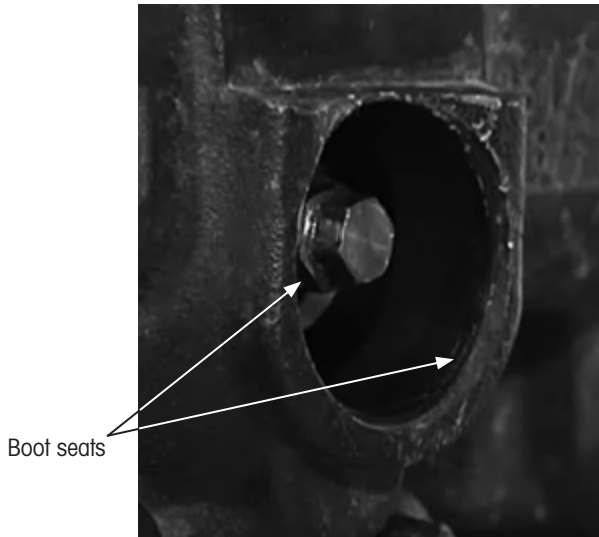
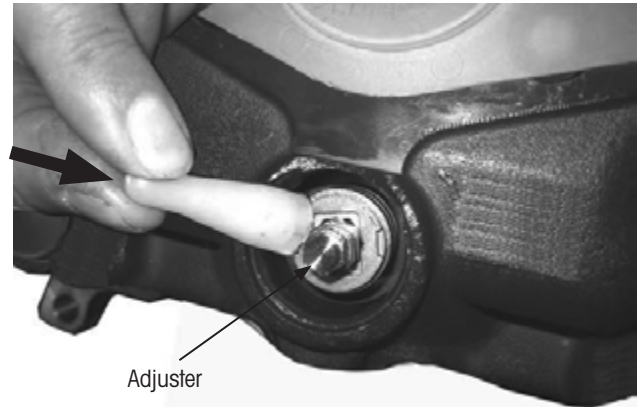

Figure 81: *Inspecting adjuster*

4. **Clean** the brake caliper adjuster boot seat. (Figure 81).

Installing Adjuster Boot

This procedure explains how to install a replacement adjuster boot using tools provided with the new boot. Use of these tools is required to prevent damage to the boot during installation.



A. Positioning mounting cap



B. Placing mounting cap over adjuster

Figure 82: *Installing mounting cap*

5. **Push** the mounting cap (Figure 82) onto the adjuster until it stops.

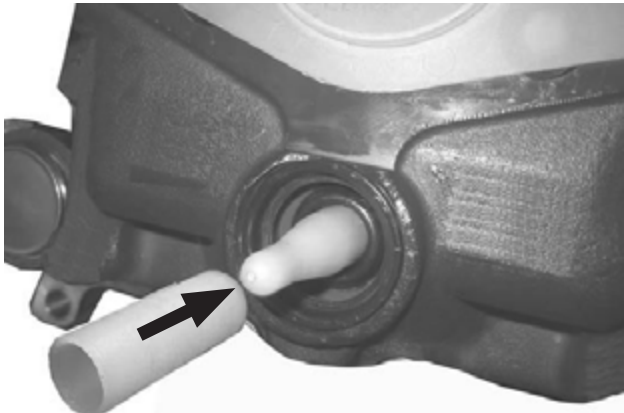

Figure 83: *Installing adjuster boot*

NOTE: Grease should be included with parts kit.



6. **Lightly grease** the new adjuster boot only at the inner boot bead as indicated in [Figure 83](#).
7. **Install** the adjuster boot onto the mounting cap.



A. **Positioning** mounting bushing above mounting cap (adjuster boot shown pressed in place)

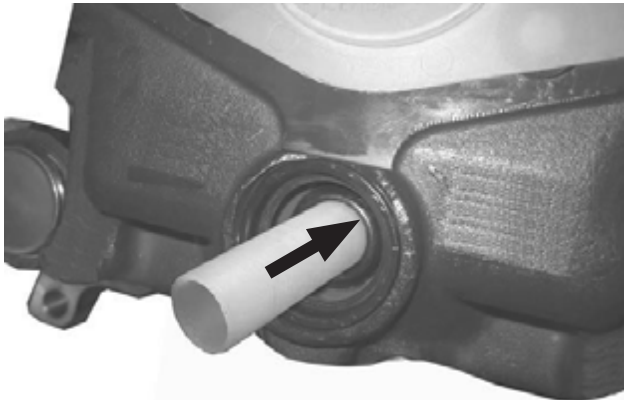

B. **Mounting** bushing over mounting cap

Figure 84: *Positing mount bushing to mounting cap*

8. **Manually press** the adjuster boot ([Figure 84](#)) fully into the brake caliper boot seat.
9. **Install** the mounting bushing ([Figure 84, A](#)) onto the mounting cap.
10. **Press** the mounting bushing ([Figure 84, B](#)) against the inner boot bead until the boot bead lies in the boot seat of the adjuster.

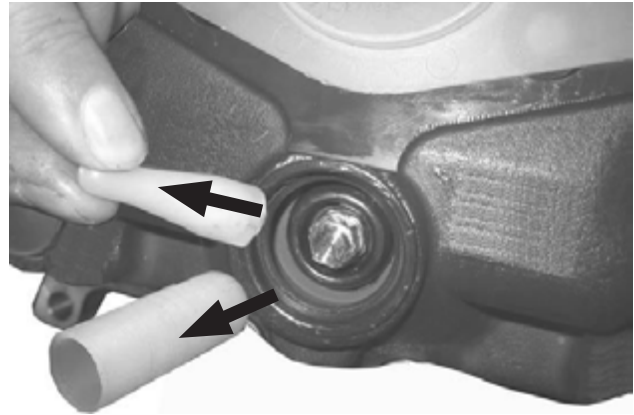

Figure 85: *Removing mounting bushing and cap*

11. **Remove** the mounting bushing and the mounting cap ([Figure 85](#)).



Boot seat on adjuster

Figure 86: *Checking adjuster boot seat*

12. **Check** correct seat of the adjuster boot ([Figure 86](#)) in the brake caliper and the boot seat.

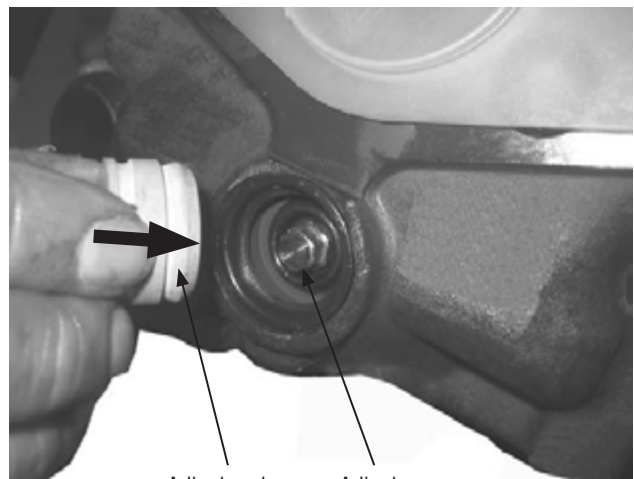

Adjuster plug Adjuster

Figure 87: *Inserting adjuster plug*

13. **Push** a new adjuster plug into the opening of the brake caliper.



Figure 88: Adjuster plug properly inserted

14. **Ensure** a tight fit.

If all applicable protection boots and/or bushings have been replaced and no other brake caliper services is required, perform as needed:

MOUNTING BRAKE CALIPER TO BRAKE CARRIER on page 28

INSTALLING THE BRAKE on page 21

INSTALLING BRAKE PADS on page 18

INSTALLING THE BRAKE CHAMBER on page 22

REPLACING DUST SHIELD



Figure 89: Dust shield

The dust shield is bolted to the torque plate with four M8 x 1.25 bolts and lock washers (Figure 89).

NOTE: The following applies to dust shield removal and installation:

- Dust shields have no left/right orientation and can be installed on either side of the axle.
- The dust shield must be mounted and fastened as shown in [Figure 89](#).
- Nuts are welded to the inside of the dust shield and cannot be accessed while the dust shield is in position.
- Replacement bolts are not provided with a new dust shield.
- It is not necessary to remove the dust shield prior to removing or servicing the brake.

To replace the dust shield:

1. Using a 13 mm socket or wrench, remove the four bolts and lock washers.
2. After the last bolt is removed, the dust shield can be separated from the torque plate.
3. Position new dust shield as shown in [Figure 89](#).
4. Reinstall fasteners and torque to 15 ft. lbs. (20 N•m).



APPENDIX A: WRENCH SIZE AND TIGHTENING TORQUES

For maintenance work on disc brakes, the following tools are required. For special Hendrickson ADB tool kits, refer to APPENDIX B: ADB TOOLS on page 37.

ITEMS	TOOL / APPLICATION	WRENCH SIZE		TIGHTENING TORQUE REMARKS
		External	Internal	
I	Adjuster Brake adjustment (Table 4 on page 37)	8 mm socket	-	Direction of rotation on the adjuster: <ul style="list-style-type: none"> Adjusting, counterclockwise (left) maximum 2.2 ft. lbs. (3 N•m), clearance decreases. Replacing pads, clockwise (right), maximum 11 ft. lbs. (15 N•m), clearance increases.
II	Screw, pad retainer bar	-	8 mm allen	22+11 ft. lbs. (30+15 N•m)
III	Screw, brake fastening	27 mm socket	-	280±11 ft. lbs. (380±14 N•m), in sequence shown below.  Always observe the installation specifications of the axle or vehicle manufacturer. Refer to Hendrickson literature no. T71004 for more details.
IV	Screw, guide pins	-	14 mm allen	Angle controlled tightening 96 ft. lbs. (130 N•m) +90° (one quarter turn). Tightening sequence for guide pins: 1. Long guide pin screw 2. Short guide pin screw
V	Nut, brake chamber	24 mm socket	-	NOTE: The brake chamber must be caged during installation. Fastening the brake chamber to the disc brake is recommended as follows: <ul style="list-style-type: none"> Thread on the fastening nuts by hand until the brake chamber makes full contact. Tighten the fastening nuts with approximately 90 ft. lbs. (122 N•m). Tighten the fastening torques with 150±25 ft. lbs. (204±34 N•m) using a torque wrench. Use fastening nuts only once.
VI	Bolt, dust shield	13 mm socket	-	15 ft. lbs. (20 N•m)

Table 3: Tool application and fastener torque values



APPENDIX B: ADB TOOLS

Unless otherwise specified, specialty tools listed in [Table 4](#) and [Table 5](#) are included in the kits.

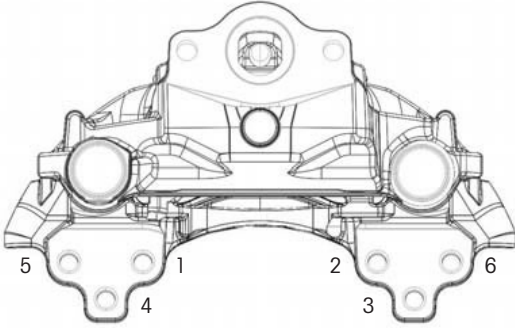
BASIC TOOLS

Required for all Hendrickson ADB brakes





TOOL #	NAME	IMAGE
10	Handle, driver (Used with tool 11 and tools listed in Table 5)	
11	Adapter, driver (Used with tool 10 and tools listed in Table 5)	
12	Gear wrench 12 mm (Used with adapter 13)	
13	8 mm adapter (Typically used with tool 12)	
	8 mm deep offset box end wrench (not included with kit, but can be used as an alternate tool for 12 & 13)	

Table 4: Basic tool kit S-32676-5



TOOLS FOR MAXX22T™

Combined with tools 10 & 11 (Table 3), these tools are used to remove or install brake components as described in this document.

NOTE: Tool numbers are stamped on the tool as shown in Figure 90.



Figure 90: Sample tool number

TOOL #	NAME	IMAGE
19, 20	(Tool included in tool kit, but not required for MAXX22T.)	
21	Bushing drive-out	
22	Bushing drive-in, long 1	
23, 24 & 25	Tools included in tool kit, but not required for MAXX22T.	
26	Bushing drive-in, short	
27	Bushing drive-in, long 1	
29	Bushing drive-in, long 2	

Table 5: MAXX22T tool set S-35303-6



APPENDIX C: EXPLODED VIEW OF REPLACEMENT PARTS

Repair kits for MAXX22T™ air disc brakes can be found at www.hendrickson-intl.com in Hendrickson literature no. L1063 *ADB parts list*.

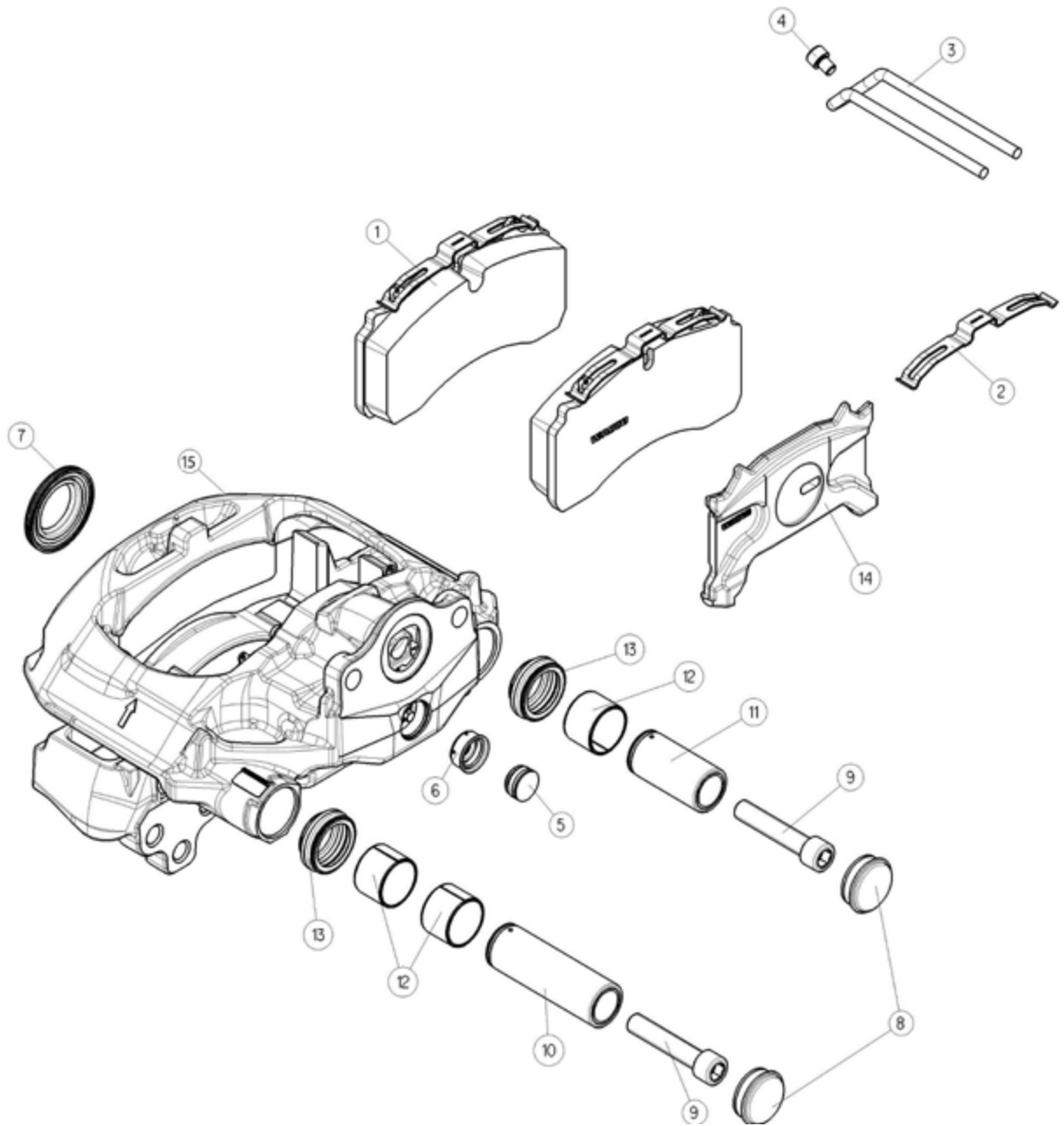

Figure91: MAXX22T exploded view

ITEM #	DESCRIPTION	ITEM #	DESCRIPTION	ITEM #	DESCRIPTION
1	Brake pad, inboard & outboard	6	Boot, adjuster	11	Guide pin (short)
2	Spring, pressure plate retainer	7	Boot, adjuster piston	12	Bushing, guide pin
3	Pad retainer bar	8	Cap, guide pin	13	Boots, guide pin
4	Screw, pad retainer	9	Screw, guide pin	14	Pressure plate
5	Plug, adjuster	10	Guide pin (long)	15	Brake caliper assembly

Call your trailer dealer or Hendrickson at **866.RIDEAIR (743.3247)** for additional information.



www.hendrickson-intl.com

TRAILER COMMERCIAL VEHICLE SYSTEMS

2070 Industrial Place SE
Canton, OH 44707-2641 USA
866.RIDEAIR (743.3247)
330.489.0045 • Fax 800.696.4416

Hendrickson Canada

250 Chrysler Drive, Unit #3
Brampton, ON Canada L6S 6B6
800.668.5360
905.789.1030 • Fax 905.789.1033

Hendrickson Mexicana

Circuito El Marqués Sur #29
Parque Industrial El Marqués
Pob. El Colorado, Municipio El Marqués,
Querétaro, México C.P. 76246
+52 (442) 296.3600 • Fax +52 (442) 296.3601