

H SALES ENGINEERING UPDATE

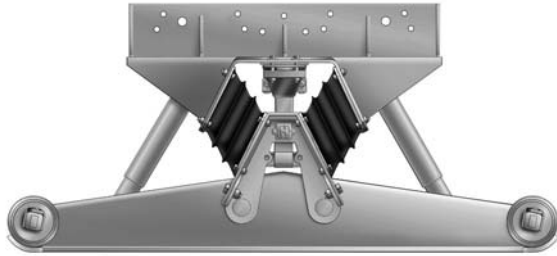

HN-402/462

NO: SEU-9802

SUBJECT: HN-402/462 Auxiliary Spring Assembly

EFFECTIVE DATE: August 1998 REVISION: A

DISCONTINUED Auxiliary Spring Assembly 58189-000

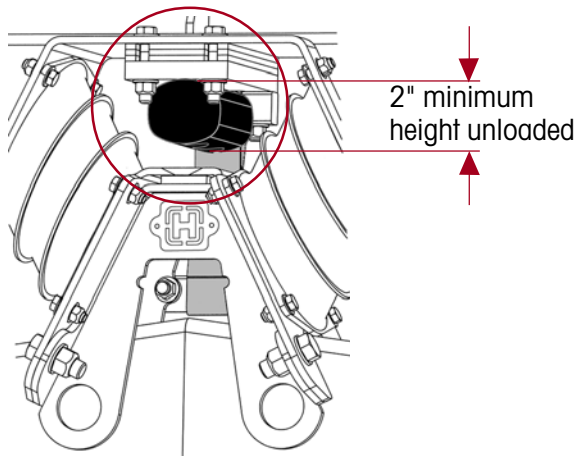

NEW Auxiliary Spring Assembly 58947-000

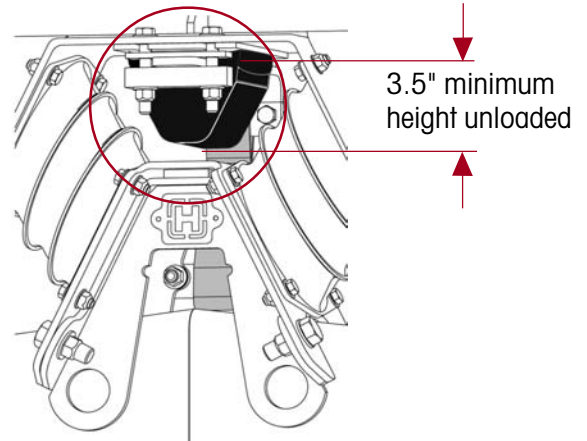

Effective August 1998, Hendrickson replaced the auxiliary spring assembly in production for the HN-402/462. The new auxiliary spring maintains a higher level of performance and durability in severe applications and is completely interchangeable with the discontinued auxiliary spring assembly. The discontinued auxiliary spring assemblies are obsolete and no longer available, see list below for the new auxiliary spring assembly kits.

Periodic inspection of the auxiliary spring is required. Replacement is needed if the unloaded height of the auxiliary spring is less than the minimum as shown in the views above. It is recommended that both sides of the tandem are replaced with the new auxiliary spring to operate properly. For HN-402/462 auxiliary spring replacement instructions, see Technical Publication 17730-227.

For more information contact your local Hendrickson parts supplier, truck dealer or call Hendrickson Tech Services at 630-910-2800.

New Service Assembly Kit

Service Kit to replace discontinued auxiliary spring:	(part no. 58189-000)	57974-011
Service Kit to replace new auxiliary spring:	(part no. 58947-000)	57974-012

H HENDRICKSON
Truck Suspension Systems
A Boler Company