

# **H** TECHNICAL PROCEDURE

## PARASTEER HD™ Single Steer and Twin Steer

**SUBJECT:** Service Instructions

**LIT NO:** 17730-267

**DATE:** October 2009

**REVISION:** A

### TABLE OF CONTENTS

<b>Section 1</b>	<b>Introduction</b> . . . . .	2	<b>Section 9</b>	<b>Component Replacement</b>	
<b>Section 2</b>	<b>Product Description</b> . . . . .	2		Fasteners . . . . .	25
<b>Section 3</b>	<b>Important Safety Notice</b> . . . . .	4		Air Spring . . . . .	25
<b>Section 4</b>	<b>Parts List</b>			Air Spring Frame Hanger and Reinforcement Bracket . . . . .	26
	• Twin Steer Forward Front and Single Steer . . . . .	8		Height Control Valve . . . . .	28
	• Twin Steer Forward Rear . . . . .	10		Shock Absorber . . . . .	29
<b>Section 5</b>	<b>Special Tools</b> . . . . .	12		Transverse Torque Rod . . . . .	30
<b>Section 6</b>	<b>Recommended Towing Procedure</b> . . . . .	13		Transverse Torque Rod Bushings . . . . .	31
<b>Section 7</b>	<b>Preventive Maintenance</b>			Beam Assembly and Thrust Washers . . . . .	33
	Component Inspection . . . . .	15		Beam Assembly Rubber Bushings . . . . .	35
	Beam Assembly Bushings and Thrust Washers . . . . .	16		Cross Member . . . . .	35
	Transverse Torque Rod . . . . .	16		Cross Channel Plate . . . . .	37
	Height Control Valve Inspection . . . . .	17		Cross Tube Assembly . . . . .	39
	Air Fitting Inspection . . . . .	18		Axle Seat . . . . .	41
	Shock Absorber Inspection . . . . .	19		Frame Hanger . . . . .	43
<b>Section 8</b>	<b>Alignment &amp; Adjustments</b>		<b>Section 10</b>	<b>Troubleshooting Guide</b> . . . . .	45
	Toe Setting . . . . .	21	<b>Section 11</b>	<b>Plumbing Diagram</b>	
	Camber . . . . .	21		• Single Steer . . . . .	46
	Caster . . . . .	21		• Twin Steer . . . . .	47
	Lateral Alignment . . . . .	21	<b>Section 12</b>	<b>Torque Specifications</b>	
	Ride Height . . . . .	22		• Twin Steer Forward Front and Single Steer . . . . .	48
				• Twin Steer Forward Rear . . . . .	50

## SECTION 1

# Introduction

This publication is intended to acquaint and assist maintenance personnel in the preventive maintenance, service, repair, and rebuild of the PARASTEER HD™ Single Steer and Twin Steer suspension system.

### NOTE

Use only  Hendrickson Genuine Parts for servicing this suspension system.

It is important to read and understand the entire Technical Procedure publication prior to performing any maintenance, service, repair, or rebuild of this product. The information in this publication contains parts lists, safety information, product specifications, features, proper maintenance, service and rebuild instructions for the PARASTEER HD suspension.

Hendrickson reserves the right to make changes and improvements to its products and publications at any time. Contact Hendrickson Tech Services at 630.910.2800 or email [tech-services@hendrickson-intl.com](mailto:tech-services@hendrickson-intl.com) for information on the latest version of this manual.

**The latest revision of this publication is also available online at [www.hendrickson-intl.com](http://www.hendrickson-intl.com).**

## SECTION 2

# Product Description

Designed for single, dual and tri-steer applications, the Hendrickson PARASTEER HD front air system is built to meet the demands of a variety of vocational and construction applications including concrete, crane, oil field, tank and other specialty trucks. PARASTEER HD is a uniquely designed suspension with no fixed maximum steer axle spacing constraints (minimum axle space of 57 inches), providing excellent axle spacing flexibility. This allows the end user, chassis manufacturer, body manufacturer and Hendrickson to work together to obtain the optimum weight distribution for the application. In addition the system weight remains constant as steer axle spacing increases, offering an increasing weight advantage over competitive systems that require longer or larger components at higher axle spacings. Available in configurations up to 20,000 lbs. per steer axle, PARASTEER HD provides outstanding performance, ride quality and handling for tough specialty applications.

- **Air springs** — equally support one hundred percent of the vertical load, cushioning the driver by isolating impacts from the road and offering more protection to the chassis and equipment
- **Four-bar linkage design** — maintains correct steering geometry under all conditions, minimizing steering error caused by rough road, hard cornering and braking
- **Dual height control valves** — adjust to the load, resulting in a constant ride height and comfortable ride
- **Heavy-duty rubber bushings** — require no lubrication

## PARASTEER HD SPECIFICATIONS

<b>Model</b>	PS 200HD
<b>Capacity</b>	Up to 20,000 lbs. per Axle
<b>Axle Travel<sup>1</sup></b>	4.7"
<b>Off-road Approval</b>	Up to 100 percent
<b>Installed Weight<sup>2</sup></b>	1,220 lbs. per dual-steer system

- <sup>1</sup> Travel may be limited by vehicle manufacturer; axle stop settings and shock stroke may restrict suspension's articulation. Varying ride heights and configurations may restrict travel.
- <sup>2</sup> Installed weight includes complete suspension, as shown above with transverse torque rods, front and rear cross members, axle seats and all suspension hardware.

**FIGURE 2-1 Single Steer**

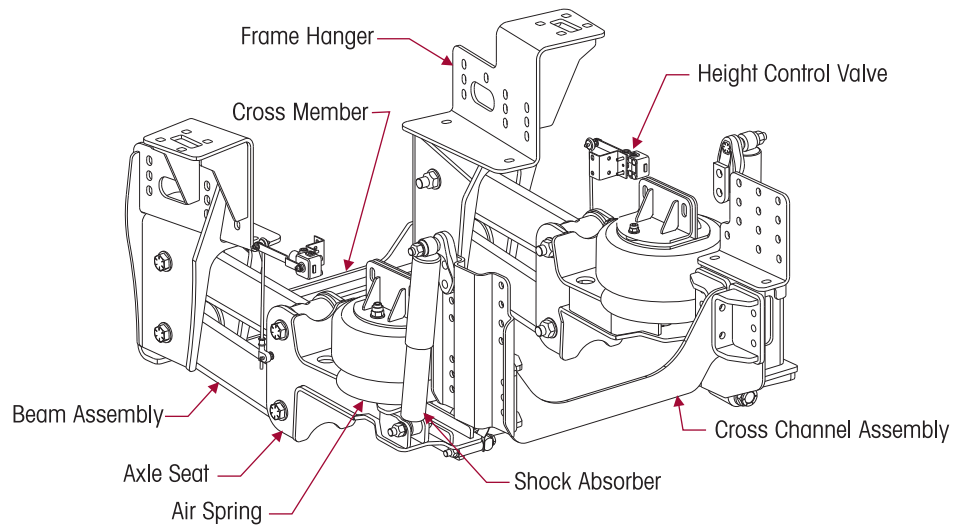

**FIGURE 2-2 Twin Steer**

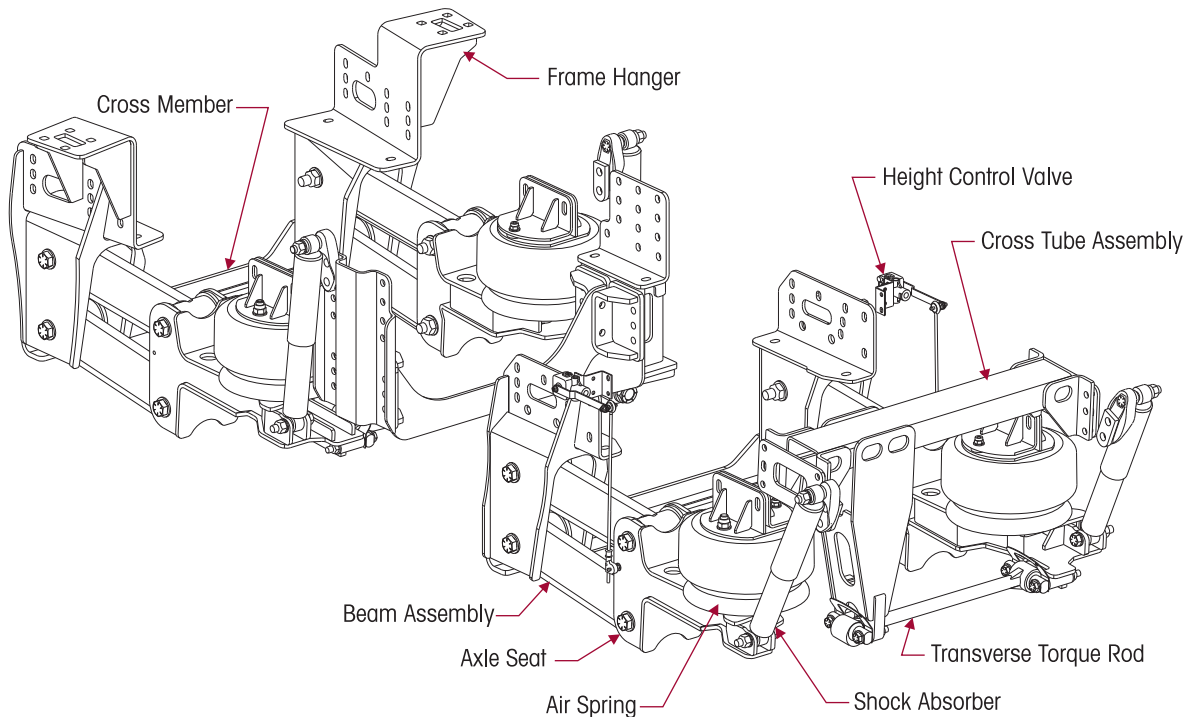

## SECTION 3

# Important Safety Notice

Proper maintenance, service and repair are important to the reliable operation of the suspension. The procedures recommended by Hendrickson and described in this technical publication are methods of performing such maintenance, service and repair.

The warnings and cautions should be read carefully to help prevent personal injury and to assure that proper methods are used. Improper maintenance, service or repair may damage the vehicle, cause personal injury, render the vehicle unsafe in operation, or void the manufacturer's warranty.

Failure to follow the safety precautions in this manual can result in personal injury and/or property damage. Carefully read and understand all safety related information within this publication, on all decals and in all such materials provided by the vehicle manufacturer before conducting any maintenance, service or repair.

## EXPLANATION OF SIGNAL WORDS

Hazard "Signal Words" (Danger-Warning-Caution) appear in various locations throughout this publication. Information accented by one of these signal words must be observed to help minimize the risk of personal injury to service personnel, or possibility of improper service methods which may damage the vehicle or render it unsafe.



This is the safety alert symbol. It is used to alert you to potential personal injury hazards. Obey all safety messages that follow this symbol to avoid possible injury or death.

Additional 'Notes' or 'Service Hints' are utilized to emphasize areas of procedural importance and provide suggestions for ease of repair. The following definitions indicate the use of these signal words as they appear throughout the publication.



INDICATES AN IMMINENTLY HAZARDOUS SITUATION WHICH, IF NOT AVOIDED, WILL RESULT IN SERIOUS INJURY OR DEATH.



INDICATES A POTENTIAL HAZARDOUS SITUATION WHICH, IF NOT AVOIDED, CAN RESULT IN SERIOUS INJURY OR DEATH.



INDICATES A POTENTIAL HAZARDOUS SITUATION WHICH, IF NOT AVOIDED, MAY RESULT IN MINOR OR MODERATE INJURY, OR PROPERTY DAMAGE.

**NOTE**

An operating procedure, practice condition, etc. which is essential to emphasize.

**SERVICE HINT**

A helpful suggestion, which will make the servicing being performed a little easier and/or faster.

Also note that particular service operations may require the use of special tools designed for specific purposes. These special tools can be found in the Special Tools Section of this publication.

## SAFETY PRECAUTIONS

 **DANGER**

### AIR SPRINGS

UNRESTRICTED AIR SPRING ASSEMBLIES CAN VIOLENTLY SHIFT. DO NOT INFLATE AIR SPRING ASSEMBLIES WHEN THEY ARE UNRESTRICTED. AIR SPRING ASSEMBLIES MUST BE RESTRICTED BY SUSPENSION OR OTHER ADEQUATE STRUCTURE. DO NOT INFLATE BEYOND PRESSURES RECOMMENDED BY AIR SPRING MANUFACTURER, CONTACT HENDRICKSON TECHNICAL SERVICES FOR DETAILS. IMPROPER USE OR OVER INFLATION MAY CAUSE AIR SPRING ASSEMBLIES TO BURST, CAUSING PROPERTY DAMAGE AND/OR SEVERE PERSONAL INJURY.

 **WARNING**

PRIOR TO AND DURING DEFLATION AND INFLATION OF THE FRONT AIR SUSPENSION SYSTEM, ENSURE THAT ALL PERSONNEL AND EQUIPMENT ARE CLEAR FROM UNDER THE VEHICLE AND AROUND THE SERVICE AREA, FAILURE TO DO SO CAN CAUSE SERIOUS PERSONAL INJURY, DEATH, OR PROPERTY DAMAGE.

 **WARNING**

### AIR SPRING PRESSURE RETENTION

SOME VEHICLE APPLICATIONS, SUCH AS VEHICLES EQUIPPED WITH OUTRIGGERS, RETAIN SOME AIR PRESSURE IN THE AIR SPRINGS AT ALL TIMES. PRIOR TO PERFORMING ANY MAINTENANCE, SERVICE, OR REPAIR OF THE SUSPENSION, VERIFY EACH AIR SPRING IS COMPLETELY DEFLATED. FAILURE TO DO SO COULD RESULT IN SERIOUS PROPERTY DAMAGE AND/OR SEVERE PERSONAL INJURY.

 **WARNING**

### FASTENERS

DISCARD USED FASTENERS. ALWAYS USE NEW FASTENERS TO COMPLETE A REPAIR. FAILURE TO DO SO COULD RESULT IN FAILURE OF THE PART OR MATING PARTS, LOSS OF VEHICLE CONTROL, PERSONAL INJURY, OR PROPERTY DAMAGE.

LOOSE OR OVER TORQUED FASTENERS CAN CAUSE COMPONENT DAMAGE, LOSS OF VEHICLE CONTROL, PROPERTY DAMAGE, OR SEVERE PERSONAL INJURY. MAINTAIN CORRECT TORQUE VALUE AT ALL TIMES. CHECK TORQUE VALUES ON A REGULAR BASIS AS SPECIFIED, USING A TORQUE WRENCH THAT IS REGULARLY CALIBRATED. TORQUE VALUES SPECIFIED IN THIS TECHNICAL PUBLICATION ARE FOR HENDRICKSON SUPPLIED FASTENERS ONLY. IF NON HENDRICKSON FASTENERS ARE USED, FOLLOW TORQUE SPECIFICATION LISTED IN THE VEHICLE MANUFACTURER'S SERVICE MANUAL.

 **WARNING**

### LOAD CAPACITY

ADHERE TO THE PUBLISHED CAPACITY RATINGS FOR THE SUSPENSIONS. ADD-ON AXLE ATTACHMENTS AND OTHER LOAD TRANSFERRING DEVICES (I.E. SLIDING FIFTH WHEELS) CAN INCREASE THE SUSPENSION LOAD ABOVE THE RATED AND APPROVED CAPACITIES WHICH COULD RESULT IN FAILURE AND LOSS OF VEHICLE CONTROL, POSSIBLY CAUSING PERSONAL INJURY OR PROPERTY DAMAGE.

 **WARNING**

### MODIFYING COMPONENTS

DO NOT MODIFY OR REWORK PARTS WITHOUT AUTHORIZATION FROM HENDRICKSON. DO NOT SUBSTITUTE OR USE REPLACEMENT COMPONENTS NOT AUTHORIZED BY HENDRICKSON. USE OF MODIFIED, REWORKED, SUBSTITUTE OR REPLACEMENT PARTS NOT AUTHORIZED BY HENDRICKSON MAY NOT MEET HENDRICKSON'S SPECIFICATIONS, AND CAN RESULT IN FAILURE OF THE PART, LOSS OF VEHICLE CONTROL, AND POSSIBLE PERSONAL INJURY OR PROPERTY DAMAGE. USE ONLY HENDRICKSON AUTHORIZED REPLACEMENT PARTS.

 **WARNING**

### TORCH/WELDING

DO NOT USE A CUTTING TORCH TO REMOVE ANY FASTENERS. THE USE OF HEAT ON SUSPENSION COMPONENTS WILL ADVERSELY AFFECT THE STRENGTH OF THESE PARTS. A COMPONENT DAMAGED IN THIS MANNER CAN RESULT IN THE LOSS OF VEHICLE CONTROL AND POSSIBLE PERSONAL INJURY OR PROPERTY DAMAGE.

 **CAUTION****PROCEDURES AND TOOLS**

A TECHNICIAN USING A SERVICE PROCEDURE OR TOOL WHICH HAS NOT BEEN RECOMMENDED BY HENDRICKSON MUST FIRST SATISFY HIMSELF THAT NEITHER HIS SAFETY NOR THE VEHICLE'S SAFETY WILL BE JEOPARDIZED BY THE METHOD OR TOOL SELECTED. INDIVIDUALS DEVIATING IN ANY MANNER FROM THE INSTRUCTIONS PROVIDED WILL ASSUME ALL RISKS OF CONSEQUENTIAL PERSONAL INJURY OR DAMAGE TO EQUIPMENT INVOLVED.

 **WARNING****SUPPORT THE VEHICLE PRIOR TO SERVICING**

PLACE THE VEHICLE ON A LEVEL FLOOR AND CHOCK THE WHEELS TO HELP PREVENT THE VEHICLE FROM MOVING. NEVER WORK UNDER A RAISED VEHICLE SUPPORTED BY ONLY A FLOOR JACK. ALWAYS SUPPORT A RAISED VEHICLE WITH SAFETY STANDS. BLOCK THE WHEELS AND MAKE SURE THE UNIT WILL NOT ROLL BEFORE RELEASING BRAKES. A JACK CAN SLIP OR FALL OVER. SERIOUS PERSONAL INJURY CAN RESULT.

 **WARNING****PERSONAL PROTECTIVE EQUIPMENT**

ALWAYS WEAR PROPER EYE PROTECTION AND OTHER REQUIRED PERSONAL PROTECTIVE EQUIPMENT TO HELP PREVENT PERSONAL INJURY WHEN PERFORMING VEHICLE MAINTENANCE, REPAIR OR SERVICE.

 **WARNING****SHOCK ABSORBERS**

THE SHOCK ABSORBERS ARE THE REBOUND TRAVEL STOPS FOR THE AIR SUSPENSIONS. ANYTIME THE FRONT AXLE ON AN PARASTEER HD SUSPENSION IS SUSPENDED IT IS MANDATORY THAT THE SHOCK ABSORBERS REMAIN CONNECTED. FAILURE TO DO SO COULD CAUSE THE AIR SPRINGS TO EXCEED THEIR MAXIMUM LENGTH, POSSIBLY CAUSING THE AIR SPRINGS TO SEPARATE FROM THE PISTON, RESULTING IN PERSONAL INJURY OR PROPERTY DAMAGE.

 **WARNING****TRANSVERSE RODS**

THE PARASTEER HD SUSPENSION INCORPORATES TRANSVERSE RODS FOR VEHICLE STABILITY. IF THESE COMPONENTS ARE DISCONNECTED OR ARE NON-FUNCTIONAL THE VEHICLE SHOULD NOT BE OPERATED. FAILURE TO DO SO CAN RESULT IN ADVERSE VEHICLE HANDLING AND POSSIBLE TIRE CONTACT WITH THE FRAME.

 **WARNING****PARTS CLEANING**

SOLVENT CLEANERS CAN BE FLAMMABLE, POISONOUS AND CAUSE BURNS. TO HELP AVOID SERIOUS PERSONAL INJURY, CAREFULLY FOLLOW THE MANUFACTURER'S PRODUCT INSTRUCTIONS AND GUIDELINES AND THE FOLLOWING PROCEDURES:

1. WEAR PROPER EYE PROTECTION.
2. WEAR CLOTHING THAT PROTECTS YOUR SKIN.
3. WORK IN A WELL-VENTILATED AREA.
4. DO NOT USE GASOLINE, OR SOLVENTS THAT CONTAIN GASOLINE. GASOLINE CAN EXPLODE.
5. HOT SOLUTION TANKS OR ALKALINE SOLUTIONS MUST BE USED CORRECTLY. FOLLOW THE MANUFACTURER'S RECOMMENDED INSTRUCTIONS AND GUIDELINES CAREFULLY TO HELP PREVENT Personal ACCIDENT OR INJURY.

DO NOT USE HOT SOLUTION TANKS OR WATER AND ALKALINE SOLUTIONS TO CLEAN GROUND OR POLISHED PARTS. DOING SO WILL CAUSE DAMAGE TO THE PARTS AND VOID WARRANTY.

**⚠ WARNING****JACKING THE VEHICLE FOR SERVICE**

DO NOT USE THE FOLLOWING COMPONENTS FOR JACKING OR AS A SUPPORT POINT FOR SERVICING THE VEHICLE, SEE FIGURE 3-1:

- CROSS MEMBER
- CROSS CHANNEL PLATE
- CROSS TUBE ASSEMBLY
- BEAM ASSEMBLY

IMPROPER JACKING AND SUPPORT METHODS WILL VOID HENDRICKSON'S WARRANTY AND CAN CAUSE STRUCTURAL DAMAGE THAT RESULT IN LOSS OF VEHICLE CONTROL, SEVERE PERSONAL INJURY OR DEATH. REFER TO THE VEHICLE MANUFACTURER FOR PROPER JACKING AND SUPPORT METHODS.

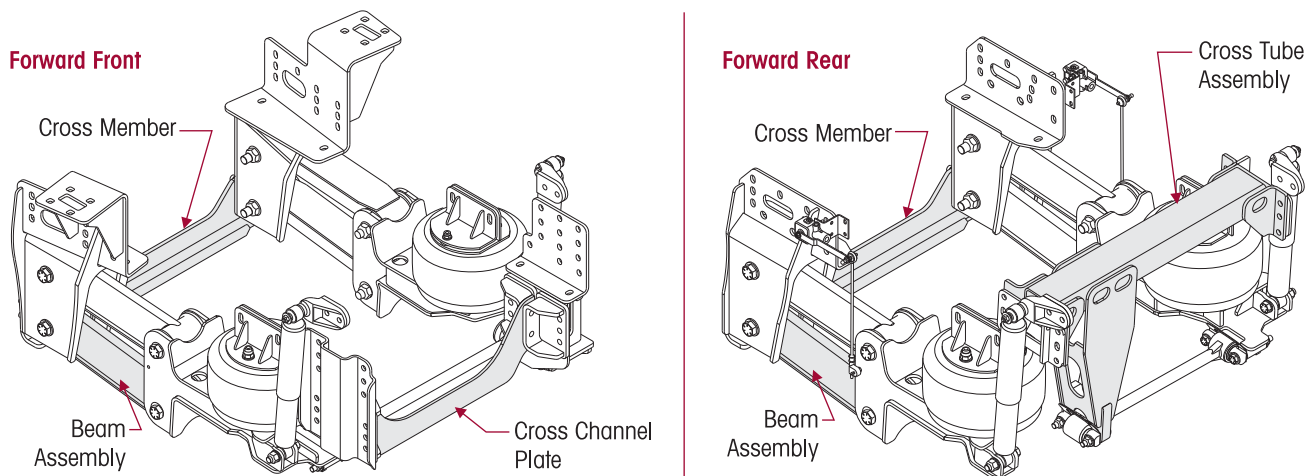
**FIGURE 3-1 Shown Twin Steer**

# SECTION 4 Parts Lists

## Twin Steer Forward Front and Single Steer

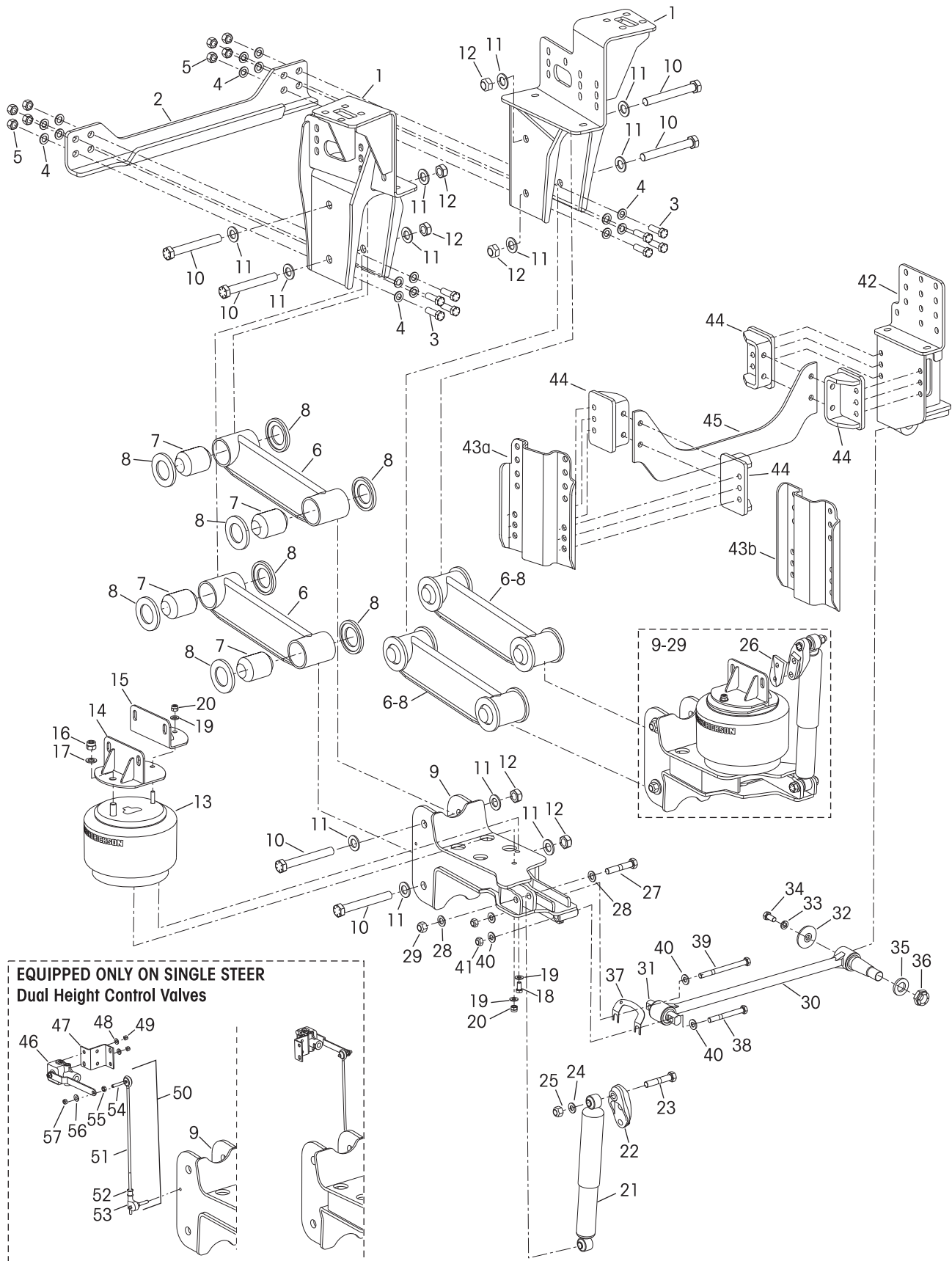





## Twin Steer Forward Front and Single Steer

KEY NO.	PART NO.	DESCRIPTION	NO.REQ.	KEY NO.	PART NO.	DESCRIPTION	NO.REQ.
1		Frame Hanger		30	62350-760	Torque Rod Assembly, Includes Key Nos. 31-36	1
	68048-001	LHF	1	31		*Torque Rod Bushings	
	68048-002	RHF	1	32		*End Washer	
2	68050-000	Cross Member	1	33		*5/8" Lockwasher	
	50763-013	<b>Cross Member Fastener Service Kit, One Side</b> Includes Key Nos. 3-5		34		*5/8"-11 UNC 1.25" Bolt	
3	50764-007	3/4"-10 UNC 2.5" Bolt	8	35		*1 1/4" Washer	
4	22962-001	3/4" Washer	16	36		*1 1/4"-12 UNF Locknut	
5	49842-000	3/4"-10 UNC Locknut	8	37	68387-000	Torque Rod Shim	As Req.
6	59536-000	Beam Assembly, Includes Key No. 7	4		49176-034	<b>Transverse Torque Rod Fastener Service Kit, One Side,</b> Includes Key Nos. 38-41	
7	59528-001	Beam Bushing	8	38	32043-019	5/8"-11 UNC 5.5" Hex Bolt	1
8	59803-000	Thrust Washer	16	39	32043-026	5/8"-11 UNC 7.5" Hex Bolt	1
9		Axle Seat		40	22962-004	5/8"-Hardened Washer	4
	68036-000	LHF	1	41	47764-000	5/8"-11 UNC Locknut	2
	68038-002	RHF	1	42		Transverse Torque Rod Bracket	1
	59568-003	<b>Pivot Bolt Kit, Axle Set,</b> Includes Key Nos. 10-12			68667-000	<i>For vehicles built after 4/2009</i>	
10	48941-002	1"-8 UNC 8.0" Bolt	8		68156-000	<i>For vehicles built prior to 4/2009</i>	
11	22962-008	1" Hardened Flat Washer	16			Cross Channel Frame Mounting Bracket	1
12	48942-000	1"-8 UNC Locknut	8	43a	68639-000	<i>For vehicles built after 4/2009</i>	
13	67793-002	Air Spring	2	43b	68117-000	<i>For vehicles built prior to 4/2009</i>	
14	67751-000	Outer Air Spring Mounting Bracket	2	44	68118-000	Cross Channel Bracket	4
15	67752-000	Inner Air Spring Mounting Bracket	2	45	68119-000	Cross Channel Plate	1
16	17700-015	3/4"-16 UNF Locknut	2		49176-036	<b>HCV Assembly Service Kit, One Side,</b> Includes Key Nos. 46, 50 • Equipped <b>ONLY</b> Single Steer Axle	
17	22962-001	3/4" Washer	2	46	57977-000	Height Control Valve Assembly	2
18	24531-011	1/2"-13 UNC 1.0" Bolt	2			Includes Key Nos. 47-49	
19	22962-011	1/2"-Hardened Flat Washer	6	47		*HCV Mounting Bracket	
20	17700-010	1/2"-13 UNC Nylocknut	4	48		*1/4"-Hardened Washer	
21	60665-005	Shock Absorber	2	49		*1/4"-20 UNC Locknut	
22	67463-001	Upper Shock Bracket	2	50	58994-010	Height Control Valve Linkage Assembly, Includes Key Nos. 51-57	2
23	50764-010	3/4"-10 UNC 4.25" Bolt	2	51		*Extension Rod	
24	22963-001	3/4" Hardened Washer	2	52		*Adjustment Valve Arm Joint	
25	49842-000	3/4"-10 UNC Locknut	2	53		*Valve Arm Clamp	
26	68623-000	Shock Bracket Spacer	1	54		*5/16"-18 UNC Valve Arm Stud	
27	50764-010	3/4"-10 UNC 4.25" Bolt	2	55		*5/16"-18 UNC Nut	
28	22962-001	3/4"- Hardened Flat Washer	4	56		*5/16"-Hardened Washer	
29	49842-000	3/4"-10 UNC Locknut	2	57		*5/16"-18 UNC Locknut	

**NOTE:** \* Item included in assembly only, part not sold separately.

# Twin Steer Forward Rear

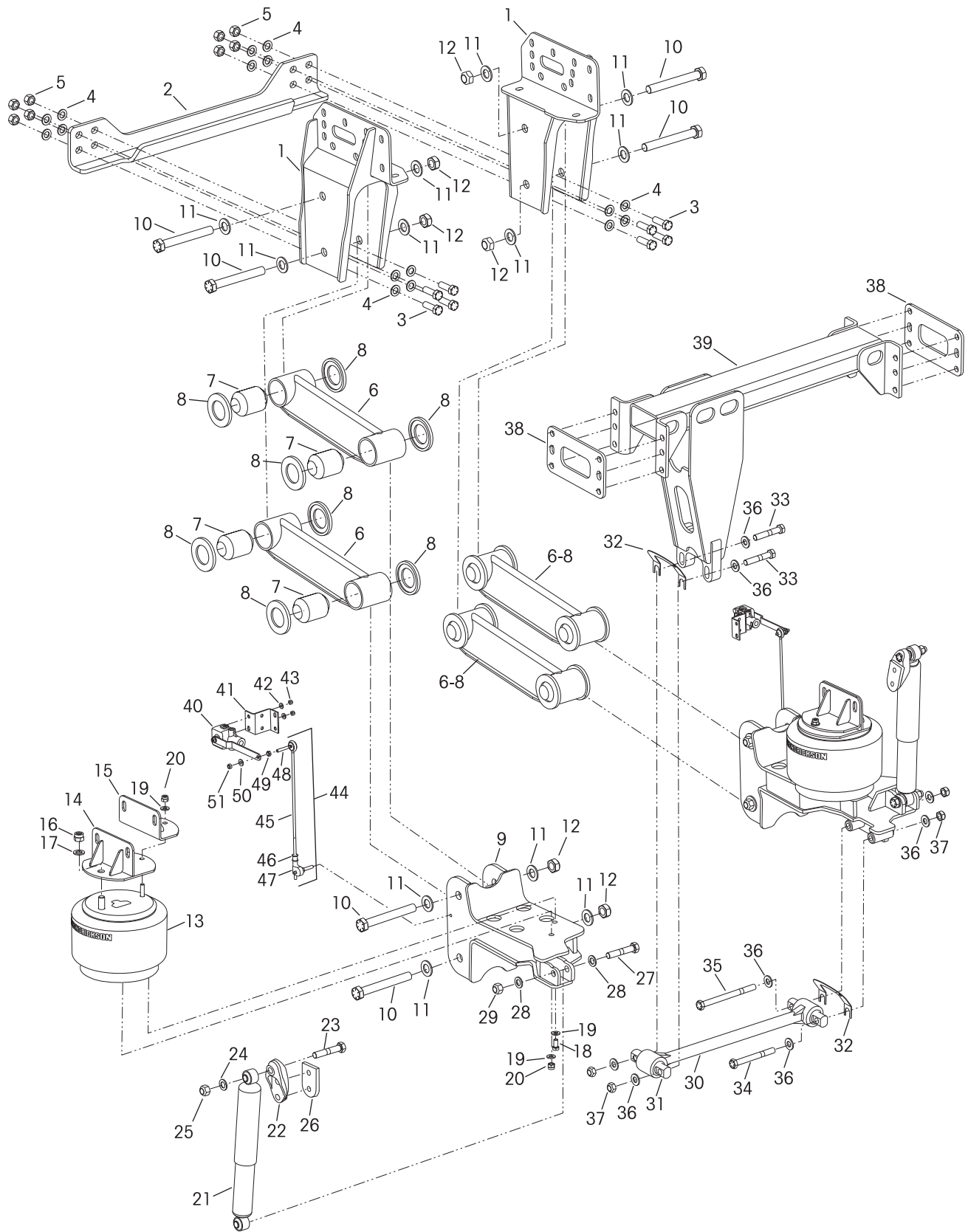



KEY NO.	PART NO.	DESCRIPTION	NO.REQ.	KEY NO.	PART NO.	DESCRIPTION	NO.REQ.
1		Frame Hanger		30	62000-565	Torque Rod Assembly, Includes Key Nos. 31	1
	68047-001	LHR	1				
	68047-002	RHR	1	31		*Torque Rod Bushing	
2	68051-000	Cross Member	2	32	68387-000	Torque Rod Shim	As Req.
	50763-013	<b>Cross Member Fastener Service Kit, One Side</b> Includes Key Nos. 3-5			49176-035	<b>Transverse Torque Rod Fastener Service Kit, One Side,</b> Includes Key Nos. 33-37	
3	50764-007	3/4"-10 UNC 2.5" Bolt	8	33	32043-009	5/8"-11 UNC 3.5" Hex Bolt	2
4	22962-001	3/4" Washer	16	34	32043-019	5/8"-11 UNC 5.5" Hex Bolt	1
5	49842-000	3/4"-10 UNC Locknut	8	35	32043-026	5/8"-11 UNC 7.5" Hex Bolt	1
6	59536-000	Beam Assembly, Includes Key No. 7	4	36	22962-004	5/8"-Hardened Washer	8
7	59528-001	Beam Bushing	8	37	47764-000	5/8"-11 UNC Locknut	4
8	59803-000	Thrust Washer	16	38	68120-000	Cross Tube Frame Bracket	2
9		Axle Seat		39	68184-000	Cross Tube Assembly	1
	68038-001	LHR	1		58525-039	<b>HCV Assembly Service Kit, One Side,</b> Includes Key Nos. 40,44	
	68037-000	RHR	1	40	57977-000	Height Control Valve Assembly Includes Key Nos. 41-43	2
	59568-003	<b>Pivot Bolt Kit, Axle Set,</b> Includes Key Nos. 10-12		41		*HCV Mounting Bracket	
10	48941-002	1"-8 UNC 8.0" Bolt	8	42		*1/4"-Hardened Washer	
11	22962-008	1" Hardened Flat Washer	16	43		*1/4"-20 UNC Locknut	
12	48942-000	1"-8 UNC Locknut	8	44	58994-002	Height Control Valve Linkage Assembly, Includes Key Nos. 45-51	2
13	67793-002	Air Spring	2			*Extension Rod	
14	67751-000	Outer Air Spring Mounting Bracket	2	45		*Adjustment Valve Arm Joint	
15	67752-000	Inner Air Spring Mounting Bracket	2	46		*Valve Arm Clamp	
16	17700-015	3/4"-16 UNF Locknut	2	47		*5/16"-18 UNC Valve Arm Stud	
17	22962-001	3/4" Washer	2	48		*5/16"-18 UNC Nut	
18	24531-011	1/2"-13 UNC 1.0" Bolt	2	49		*5/16"-Hardened Washer	
19	22962-011	1/2"-Hardened Flat Washer	6	50		*5/16"-18 UNC Locknut	
20	17700-010	1/2"-13 UNC Nylocknut	4	51			
21	60665-005	Shock Absorber	2				
22	67463-001	Upper Shock Bracket Assembly	2				
23	50764-010	3/4"-10 UNC 4.25" Bolt	2				
24	22962-001	3/4"-Hardened Flat Washer	2				
25	49842-000	3/4"-10 UNC Locknut	2				
26	68623-000	Shock Bracket Spacer	2				
27	50764-010	3/4"-10 UNC 4.25" Bolt	2				
28	22962-001	3/4"-Hardened Flat Washer	4				
29	49842-000	3/4"-10 UNC Locknut	2				

NOTE: \* Item included in assembly only, part not sold separately.

## SECTION 5 Special Tools

These shop made tools are designed to install and remove bushings. Bushing tools are made from cold rolled steel or equivalent. Drawings are for reference only. Hendrickson does not supply these tools.

### BUSHING TOOLS

**Rubber Bushing  
Receiving Tool**

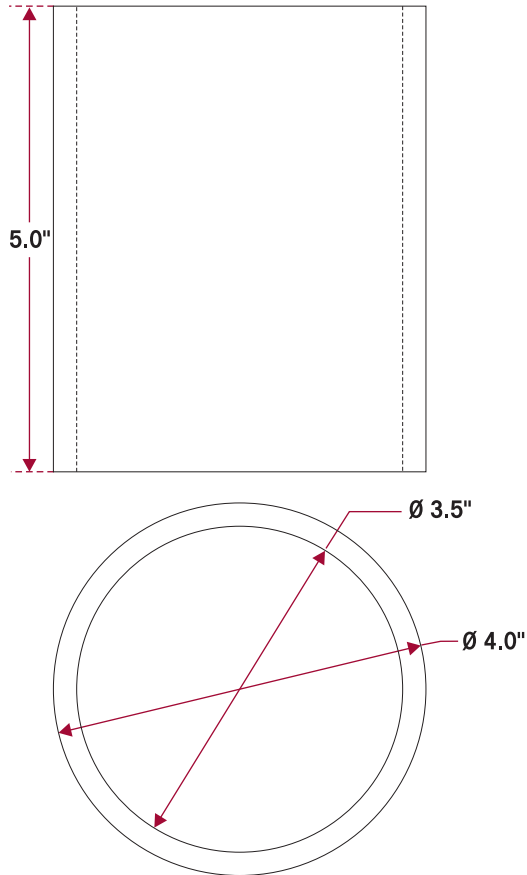

**Torque Rod Bushing  
Receiving Tool**

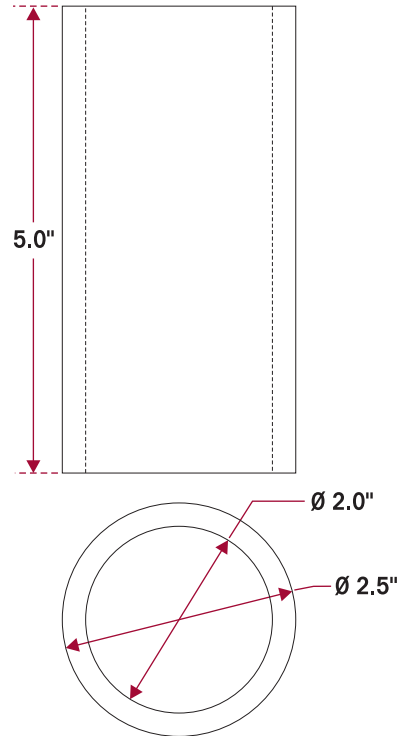

## SECTION 6

# Recommended Towing Procedure

### ON HIGHWAY AND ON ROADWAY

Hendrickson recommends that a vehicle equipped with a PARASTEER HD suspension be towed by the following methods (listed in order of preference) for ON HIGHWAY or ON ROADWAY towing.

1. Wheel lift method, the ideal towing procedure
2. Towing the vehicle from the rear method
3. Conventional axle fork method

Please read, understand and comply with any additional towing instructions and safety precautions that may be provided by the vehicle manufacturer.

Hendrickson will not be responsible for any damage to the axle, suspension or other vehicle components resulting from any towing method or fixture not authorized by Hendrickson.

Please contact Hendrickson Tech Services for any questions regarding proper towing procedures for vehicles equipped with the PARASTEER HD suspension at 630.910.2800 or send email to: [techservices@hendrickson-intl.com](mailto:techservices@hendrickson-intl.com)

### WHEEL LIFT METHOD — IDEAL

#### NOTE

When using the wheel lift method for towing a vehicle equipped with the twin steer version of the PARASTEER HD, the suspension must be deflated and the forward-rear axle must be secured to the frame in the collapsed position. Failure to do so can result in damage to the suspension, axle or tires.

This method provides the greatest ease for towing the vehicle. Lifting at the tires helps reduce the risk of possible damage to the axle, suspension, and engine components during towing operations, see Figure 6-1.

**FIGURE 6-1 WHEEL LIFT METHOD**



### TOWING VEHICLE FROM THE REAR METHOD

This method is preferred when the proper equipment is not available to perform the wheel lift method and is necessary for wreckers not equipped with an under lift system.

### AXLE FORK LIFT METHOD

This is an alternative method for towing the vehicle. Consult the vehicle manufacturer or the axle manufacturer for specific vehicle towing instructions with this method.

---

#### NOTE

When lifting a vehicle with an under lift boom, care must be taken not to damage the engine's oil pan. Vehicles equipped with a front fairing may require removal of the front fairing prior to towing to prevent component damage.

---

### OFF ROADWAY TOWING METHOD



#### WARNING

WHEN A VEHICLE IS DISABLED AND EQUIPPED WITH A PARASTEER HD SUSPENSION, CARE MUST BE TAKEN TO ENSURE THERE IS NO DAMAGE TO THE SUSPENSION OR AXLE WHEN TOWING THE VEHICLE. WHEN THE USE OF A TOW STRAP IS NECESSARY TO MOVE A DISABLED TRUCK OFF ROADWAY, SUCH AS FROM A REPAIR FACILITY'S YARD INTO THE REPAIR FACILITY'S SHOP, THE TOW STRAPS SHOULD BE CONNECTED TO THE TOW HOOKS PROVIDED BY THE VEHICLE MANUFACTURER AT THE FRONT OF THE BUMPER. IF THE USE OF TOW HOOKS IS NOT AN OPTION, CONSULT THE VEHICLE MANUFACTURER OR THE AXLE MANUFACTURER FOR SPECIFIC INSTRUCTIONS FOR OFF ROADWAY TOWING.

## SECTION 7

# Preventive Maintenance

Hendrickson recommends that preventive maintenance be performed on a regular basis to ensure all components function to their highest efficiency. Proper preventive maintenance programs will help control repair costs, eliminate downtime, and provide safe and reliable operation. All new equipment should be given an initial pre-service inspection.

### HENDRICKSON RECOMMENDED PREVENTIVE MAINTENANCE INTERVALS

- **After the first 1,000 miles**
- **Every 25,000 miles or every 6 months**, whichever comes first

### COMPONENT INSPECTION

- **Air spring** — Look for chaffing or any signs of spring or component damage.
- **Air supply (Pneumatic components)** — The air supply to the system plays a large role in the air springs' performance. Inspect, clean and replace, if necessary, any support products to the air springs, valves, regulators and air lines.
- **Axle seat** — Check for cracks. Replace if necessary, see the Component Replacement Section of this publication for replacement procedure.
- **Beam assembly** — Check for cracks. Replace if cracked or broken. Check the front and rear bushings for any wear or deterioration. Replace beam assembly if any of the previous conditions are observed, see the Component Replacement Section in this publication for replacement procedure.
- **Cross member / Cross channel / Cross tube** — Inspect the cross member / cross channel / cross tube for any signs of cracks, damage, metal shavings or looseness. Visually inspect the overall condition for dents, dings or other damage. Check all fasteners for proper torque. Replace all worn or damaged parts.
- **Fasteners** — Look for any loose or damaged fasteners on the entire suspension. Make sure all fasteners are tightened to the specified torque. Refer to  Torque Specifications Section of this publication. Use a calibrated torque wrench to check torque in a tightening direction. As soon as the fastener starts to move, record the torque. Correct the torque if necessary. Replace any worn or damaged fasteners.

#### NOTE

Hendrickson recommends the use of Grade 8 bolts and Grade C locknuts for all suspension component attachments.

- **Frame hangers** — Check for cracks or loose mounting hardware. Replace if necessary, see the Component Replacement Section of this publication for replacement procedure.
- **Height control valve and Air lines** — Check the suspension air system for air leaks. Check all air lines for proper routing. Check for chafing or pinched air lines. Check the height control valve linkage for damage or interference with peripheral components.
- **Shock absorber** — Look for any signs of dents or leakage, misting is not considered a leak, see Shock Absorber Inspection in this section.
- **Thrust washers** — Look for any signs of excessive wear to the thrust washers, see Beam Assembly Bushings and Thrust Washers in this section.
- **Tire wear** — Inspect tires for wear patterns that may indicate suspension damage or misalignment.
- **Transverse torque rods** — All torque rods must be inspected for looseness, torn or shredded rubber, bushing walk-out, and for proper fastener torque. If there is metal-to-metal contact in the bushing joint, this is a sign of excessive bushing wear and the bushing needs to be replaced.

- **Wear and damage** — Inspect all parts of suspension for wear and damage. Look for bent or cracked parts. Replace all worn or damaged parts.

See vehicle manufacturer's applicable publications for other preventative maintenance requirements.

## BEAM ASSEMBLY BUSHINGS AND THRUST WASHERS

### NOTE

If one bushing or thrust washer in a beam assembly requires replacement, Hendrickson recommends all bushings and all thrust washers be replaced.

For beam bushing and thrust washer replacement, see Component Replacement Section of this publication.

An indication that the rubber bushing and thrust washers may be worn and require replacement is when the suspension exhibits one or more of the following conditions:

- Excessive lateral movement of the axle (axle movement evaluation).
- Thrust washers show successive grooves as shown in Figure 7-1.
- Suspension noise during operation. Contact Hendrickson Tech Services for more information at 630-910-2800 or email [techservices@hendrickson-intl.com](mailto:techservices@hendrickson-intl.com).

FIGURE 7-1



## TRANSVERSE TORQUE RODS

### WARNING

THE PARASTEER HD SUSPENSION INCORPORATES TRANSVERSE RODS FOR VEHICLE STABILITY. IF THESE COMPONENTS ARE DISCONNECTED OR ARE NON-FUNCTIONAL THE VEHICLE SHOULD NOT BE OPERATED. FAILURE TO DO SO CAN RESULT IN ADVERSE VEHICLE HANDLING AND POSSIBLE TIRE CONTACT WITH THE FRAME.

All torque rods and mounting hardware need to be inspected for damage and proper fastener torque at recommended preventative maintenance intervals. It is important that the tightening torque of the locknuts be checked during preventative maintenance. Follow the torque recommendations found in the Torque Specification section of this publication. The torque rod can be visually inspected for damage by the following method.

- **Method** — With the vehicle shut down, a lever check can be made with a long pry bar placed under each rod end and pressure applied.

Visually inspect torque rod bushings for torn or shredded rubber, inspect for bent, cracked, or broken torque rods and also for end hubs that have an elongated "oval" shape. Any of these conditions require component replacement.

The transverse torque rods center the axles under the frame. If the lateral alignment of the axles is incorrect, it may be necessary to shim the transverse torque rod at the straddle mount end of the torque rod. Shims can be installed between the transverse torque rod and the transverse torque rod frame bracket or between the transverse torque rod and axle seat. Refer to vehicle manufacturer for proper shim location; also see Lateral Alignment in the Alignment & Adjustments Section of this publication.



**FIGURE 7-2**

Torque rods may have attaching ends designated "straddle mount," or "tapered stud," as shown in Figure 7-2. Whether the rod ends are straddle mount, or tapered stud, torque rod bushings can be replaced by pressing out the worn end, and installing a replacement bushing. See Component Replacement Section of this publication.

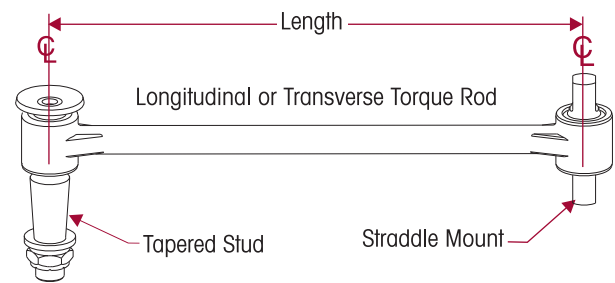

A two-piece **transverse torque rod** is available to cut and weld to the desired length, see Hendrickson Literature No. 45745-148.

**NOTE**

Hendrickson recommends the use of Grade 8 bolts and Grade C locknuts for all straddle mount torque rod attachments.

### HEIGHT CONTROL VALVE INSPECTION

The height control valve test can be done with Barksdale Test Kit (KD 2230). To order contact Barksdale at 1.800.835.1060 or visit [www.barksdale.com](http://www.barksdale.com). If the Barksdale Inc. kit is used, follow their instructions.

If using shop tools, you will need the following for proper testing:

- 160 pound minimum gauge that has a five (5) pound graduation marks with a 1/4" male brass connection
- 2" long 1/4" Tubing inserted into brass connection of gauge
- 1/4" Female straight adapter that mates to 1/4" air hose
- 1/4" NPT-1/4" PTC Fitting
- 1/4" NPT Plug
- Centering Pin (1/8" wooden dowel rod)
- Tool for air line removal

### INSTRUCTIONS

1. Disconnect the height control linkage from the height control valve arm.
2. Lower height control valve linkage arm down to exhaust air from the suspension system.
3. Clean area around air fittings.
4. Disconnect the air lines from the air springs to the valve, at C1 and C2.
5. Plug C2 port.
6. Attach gauge tubing on C1 port, see Figure 7-3.
7. Apply lubricant on tubing end to facilitate installation.
8. Move handle up to **FILL** mode. This pressurizes the test valve/gauge.
9. Move valve arm towards center and install centering pin in holes on the valve arm and the valve housing, as shown in Figure 7-4. Care must be exercised so as not to overshoot the center (blocked) mode of the valve, as this will cause the test volume to be exhausted.

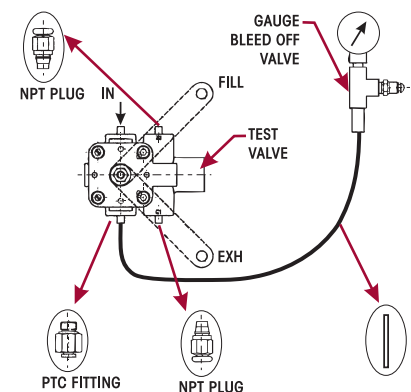
**FIGURE 7-3**

10. Observe the pressure reading on gauge.
11. Observe pressure reading for a period of 30 seconds.
12. Refer to Figure 7-5 for maximum allowable pressure drop vs. inlet pressure in 30 seconds. Valve is good if pressure drop does not exceed maximum allowable.

FIGURE 7-4

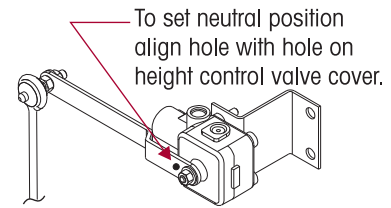

13. Replace the height control valve if maximum allowable increase is exceeded.
14. Reconnect linkage and air spring lines to valve cylinder ports.
15. If valve meets all the above characteristics, the valve is operating properly. Do not attempt to disassemble or repair valve, as this will void warranty.

FIGURE 7-5

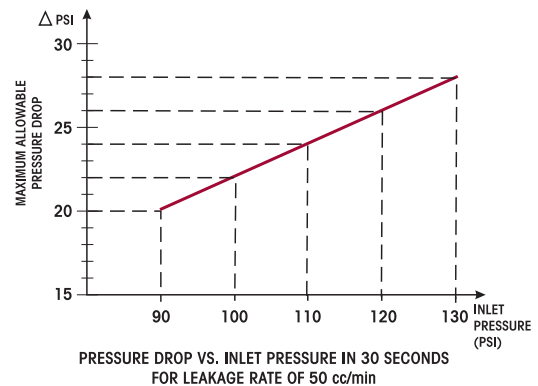

## AIR FITTING INSPECTION

1. If an air leak is suspected, begin by building up the air system to normal operating pressure.
2. Spray all nylon tube air fittings with a soapy water solution to detect the leak location.

### NOTE

Air lines and fittings may be inspected for leaks using a soapy water solution. The height control valve, however, cannot be inspected using this method. All height control valves have an allowable leakage rate. The only acceptable method for inspection of the height control valves is the height control valve test found in this section.

3. If an air leak is located, ensure the tubing end is clean and in good condition and the end is cut square. Check to see if the tubing is binding, bent or being pulled upon.
4. Visually inspect the air fitting for signs of damage or contamination.

## SHOCK ABSORBER INSPECTION

Hendrickson uses a long service life, premium shock absorber on all PARASTEER HD suspensions. When the shock absorber replacement is necessary, Hendrickson recommends that the shock absorbers be replaced with identical Hendrickson Genuine parts for servicing. Failure to do so will affect the suspension performance, durability, and will void the warranty.

Inspection of the shock absorber can be performed by doing a heat test, and a visual inspection. For instructions on shock absorber replacement see Component Replacement Section of this publication. It is not necessary to replace shock absorbers in pairs if one shock absorber requires replacement.

### HEAT TEST

1. Drive the vehicle at moderate speeds on rough road for minimum of fifteen minutes.

**WARNING**

**DO NOT GRAB THE SHOCK AS IT COULD POSSIBLY CAUSE PERSONAL INJURY.**

2. Lightly touch the shock body carefully below the dust cover.
3. Touch the frame to get an ambient reference. A warm shock absorber is acceptable, a cold shock absorber should be replaced.
4. To inspect for an internal failure, remove and shake the suspected shock. Listen for the sound of metal parts rattling inside. Rattling of metal parts can indicate that the shock has an internal failure.

**FIGURE 7-6**



### VISUAL INSPECTION

Look for these potential problems when doing a visual inspection. Inspect the shock absorbers fully extended. Replace as necessary.

**FIGURE 7-7**



### LEAKING VS. MISTING SHOCK VISUAL INSPECTION

The inspection must not be conducted after driving in wet weather or a vehicle wash; shocks need to be free from water. Many shocks are often mis-diagnosed as failures. Misting is the process whereby very small amounts of shock fluid evaporate at a high operating temperature through the upper seal of the shock. When the "mist" reaches the cooler outside air, it condenses and forms a film on the outside of the shock body. Misting is perfectly normal and necessary function of the shock. The fluid which evaporates through the seal area helps to lubricate and prolong the life of the seal.

A shock that is truly leaking and needs to be replaced will show signs of fluid leaking in streams from the upper seal. These streams can easily be seen when the shock is fully extended, underneath the main body (dust cover) of the shock. Look for these potential problems when doing a visual inspection. Inspect the shock absorbers fully extended. Replace as necessary.

**NOTE**

The PARASTEER HD suspension is equipped with a premium seal on the shock, however this seal will allow for misting to appear on the shock body (misting is not a leak and is considered acceptable).

If the shock is damaged, install a new shock absorber as detailed in the Component Replacement Section of this publication.

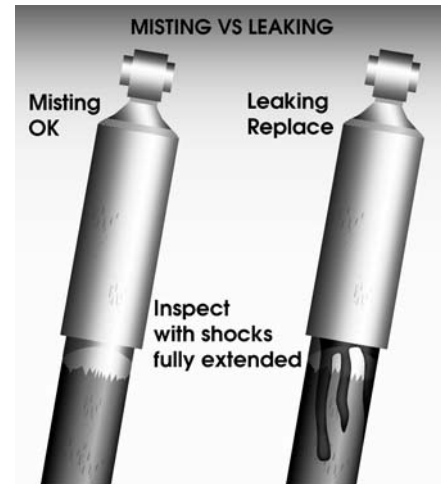
**FIGURE 7-8**

## SECTION 8

# Alignment & Adjustments

### TOE SETTING

**NOTE** Toe settings on the PARASTEER HD are adjustable. Contact the vehicle manufacturer or axle manufacturer regarding toe setting adjustment and specifications.

### CAMBER

**NOTE** Camber on the PARASTEER HD is not adjustable. The camber is built into the axle and steering knuckle assembly. Contact the vehicle manufacturer or axle manufacturer regarding camber settings.

### CASTER

**NOTE** Caster and cross caster on the PARASTEER HD are not adjustable. The caster angle is built into the axle seat. If caster or cross caster measurements are outside of manufacturer's specifications, verify vehicle ride height is correct and inspect suspension for bent, cracked, or damaged suspension components. **CASTER WEDGES ARE NOT ALLOWED.**

CASTER <sup>1,2</sup>	DESIGN SPECIFICATION	RANGE	
		MINIMUM	MAXIMUM
LEFT	3.65° ± 1.0°	+2.65°	+4.65°
RIGHT	3.65° ± 1.0°	+2.65°	+4.65°

#### CASTER NOTES:

- 1 Caster is determined with the vehicle at specified ride height for air suspension or at rated load for mechanical suspension systems. It is critical that the vehicle front and rear ride height is within specifications prior to performing a caster measurement or adjustment. See Hendrickson ride height specifications and procedure in this publication.
- 2 In most cases actual vehicle caster is defined with the frame rails at zero slope. Refer to the vehicle manufacturer's specifications for correct frame rail slope. (Both the alignment surface and the vehicle's frame rails should be level during execution of alignment procedures). For vehicles with a positive frame rake (higher in rear) add the frame slope (in degrees) to the caster reading to determine true vehicle caster.

### LATERAL ALIGNMENT

Lateral alignment or centering of the axle under the frame rail can be adjusted by adding or removing shims between the torque rod straddle mount and the cross tube assembly and/or axle seat as necessary. Contact the vehicle manufacturer for lateral alignment inspection procedures and specifications.

**FIGURE 8-1**

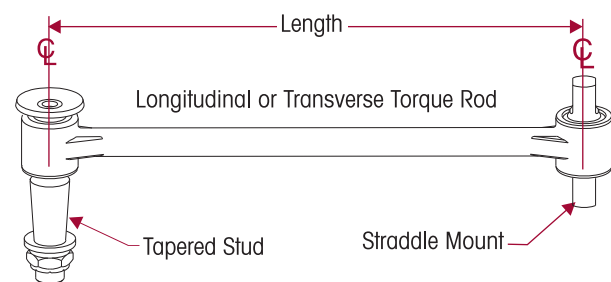

**NOTE** Torque rods with both taper pin mount and straddle mount can only be adjusted at the straddle mount end.

## RIDE HEIGHT

The PARASTEER HD is equipped with dual height control valves. The height control valves are located on opposite sides of the vehicle. On the PARASTEER HD Twin Steer, the height control valves are located on the forward rear axle. Refer to the Plumbing Diagram Section of this publication.

FIGURE 8-2



### RIDE HEIGHT INSPECTION

1. Drive the vehicle onto a level surface.
2. Free and center all suspension joints by slowly moving vehicle back and forth several times without using the brakes. **When coming to a complete stop, make sure the brakes are released.** End with all wheels positioned straight ahead. Try to roll to a stop without the brakes being used. **DO NOT** set the parking brake.
3. Chock front wheels of the vehicle.
4. When checking or adjusting ride height, verify and maintain the vehicle's air system at full operating pressure.

### SERVICE HINT

It is very important that the leveling valves be cycled completely before and after any ride height adjustments. The cycling of the leveling valve will help to make the adjustment more accurate.



### WARNING

PRIOR TO AND DURING DEFLATION AND INFLATION OF THE AIR SUSPENSION SYSTEM, ENSURE THAT ALL PERSONNEL AND EQUIPMENT ARE CLEAR FROM UNDER THE VEHICLE AND AROUND THE SERVICE AREA, FAILURE TO DO SO CAN CAUSE SERIOUS PERSONAL INJURY, DEATH, OR PROPERTY DAMAGE.

5. See additional Air Spring Cautions and Warnings in the Important Safety Notice Section of this publication prior to deflating or inflating the air system.



### WARNING

SOME VEHICLE APPLICATIONS, SUCH AS VEHICLES EQUIPPED WITH OUTRIGGERS, RETAIN SOME AIR PRESSURE IN THE AIR SPRINGS AT ALL TIMES. PRIOR TO PERFORMING ANY MAINTENANCE, SERVICE, OR REPAIR OF THE SUSPENSION, VERIFY EACH AIR SPRING IS COMPLETELY DEFLATED. FAILURE TO DO SO COULD RESULT IN SERIOUS PROPERTY DAMAGE AND/OR SEVERE PERSONAL INJURY.

6. Deflate the suspension by using one of the following appropriate methods:

- a. If vehicle is equipped with a suspension dump system in the cab, deflate the suspension air system by using the cab dump valve control.
- b. If not equipped with a suspension dump system, detach the upper rubber grommets of the height control valve linkages from the leveling valve arms and exhaust the suspension system air by lowering the leveling valve arms, see Figure 8-3.

FIGURE 8-3

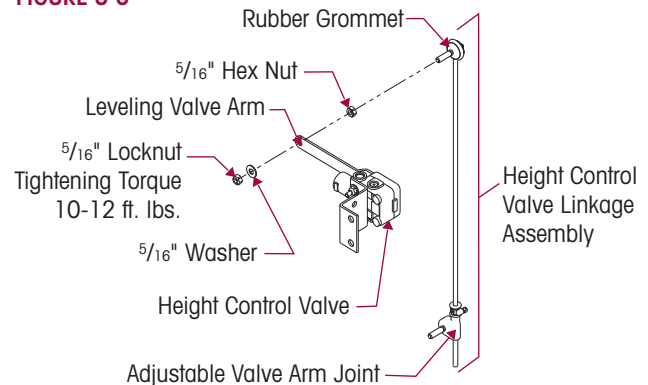

### WARNING

PRIOR TO AND DURING DEFLATION AND INFLATION OF THE AIR SUSPENSION SYSTEM, ENSURE THAT ALL PERSONNEL AND EQUIPMENT ARE CLEAR FROM UNDER THE VEHICLE AND AROUND THE SERVICE AREA, FAILURE TO DO SO CAN CAUSE SERIOUS PERSONAL INJURY, DEATH, OR PROPERTY DAMAGE.

7. Inflate the suspension by using one of the following methods:
  - a. If the vehicle is equipped with a suspension dump system in the cab, inflate the suspension air system by using the cab dump valve control. Allow the suspension system to inflate.
  - b. If the vehicle is not equipped with a suspension dump system, raise the leveling valve arms and attach the upper rubber grommets of the height control valve linkage to the leveling valve arms. Allow the suspension system to inflate.
8. Measure the suspension reference ride height using Method **A** or **B**. Ride height must be measured at each height control valve location.
 

**Method A** — Design ride height

  - a. Measure from the bottom of the frame rail to the axle centerline.
  - b. The ride height dimension should be  $7.5" \pm 1/8"$ , see dimension "A" in Figure 8-4.

**Method B** — Reference ride height measuring shock absorber length.

  - a. Using a tape measure, measure the distance between centerline of the upper and lower shock absorber mounting bolt.
  - b. The referenced ride height measurement should be  $19.47" \pm 1/8"$ , see dimension "B" in Figure 8-4.
9. Compare the measured ride height dimensions to the specified dimension ( $\pm 1/8"$ ) for your suspension in Figure 8-4.
  - a. If ride height at each height control valve location is correct then height control valve adjustment is not required.
  - b. If ride height at either height control valve location **IS NOT** correct then height control valve adjustment is required, refer to the Ride Height Adjustment in this section.

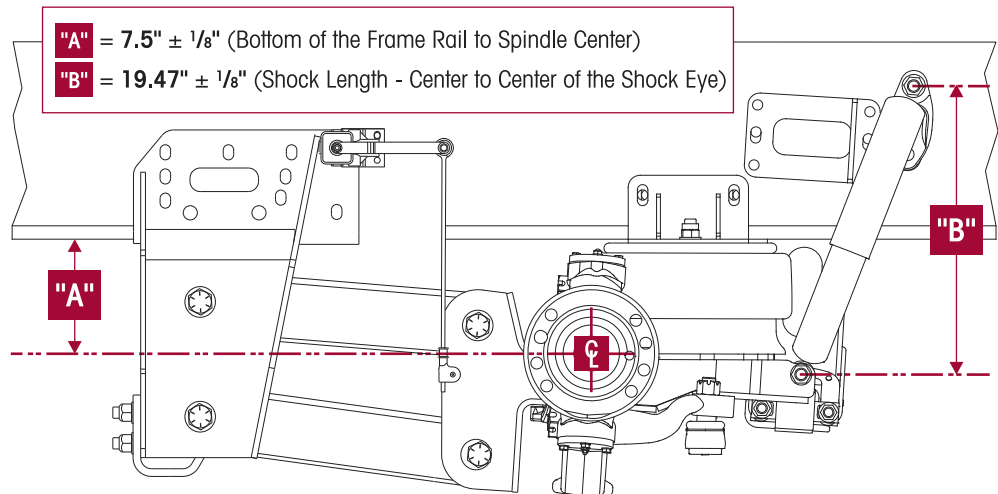
**FIGURE 8-4**

### RIDE HEIGHT ADJUSTMENT

1. Drive the vehicle onto a level surface.
2. Free and center all suspension joints by slowly moving vehicle back and forth several times without using the brakes. **When coming to a complete stop, make sure the brakes are released.** End with all wheels positioned straight ahead. Try to roll to a stop without the brakes being used. **DO NOT** set the parking brake.
3. Chock front wheels of the vehicle.
4. When checking or adjusting ride height, verify and maintain the vehicle's air system at full operating pressure.

**SERVICE HINT**

It is very important that the leveling valves be cycled completely before and after any ride height adjustments. The cycling of the leveling valves will help to make the adjustment more accurate.

**WARNING**

PRIOR TO AND DURING DEFLATION AND INFLATION OF THE AIR SUSPENSION SYSTEM, ENSURE THAT ALL PERSONNEL AND EQUIPMENT ARE CLEAR FROM UNDER THE VEHICLE AND AROUND THE SERVICE AREA, FAILURE TO DO SO CAN CAUSE SERIOUS PERSONAL INJURY, DEATH, OR PROPERTY DAMAGE.

5. See additional Air Spring Cautions and Warnings in the Important Safety Notice Section of this publication prior to deflating or inflating the air system.

**WARNING**

SOME VEHICLE APPLICATIONS, SUCH AS VEHICLES EQUIPPED WITH OUTRIGGERS, RETAIN SOME AIR PRESSURE IN THE AIR SPRINGS AT ALL TIMES. PRIOR TO PERFORMING ANY MAINTENANCE, SERVICE, OR REPAIR OF THE SUSPENSION, VERIFY EACH AIR SPRING IS COMPLETELY DEFLATED. FAILURE TO DO SO COULD RESULT IN SERIOUS PROPERTY DAMAGE AND/OR SEVERE PERSONAL INJURY.

6. Detach the upper rubber grommets of the height control valve linkages from the leveling valve arms and exhaust the suspension system air by lowering the leveling valve arms.
7. Refill the suspension by raising the height control valve arms by hand, so that the air springs are above the proper ride height.
8. Lower the leveling valve arms to exhaust the suspension air system until the suspension is at proper ride height.

**NOTE**

Adjustments to one height control valve may affect ride height setting on the other height control valve. Verify ride height is correct at both height control valves whenever an adjustment is made.

9. Use a 1/8" wooden dowel rod (golf tee) to set the neutral position for each height control valve by aligning the hole in the leveling arm with the hole in the height control valve cover, as shown in Figure 8-5. **DO NOT** use a metal rod or nail as this may cause damage to the height control valve.

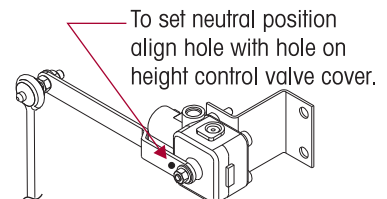
**FIGURE 8-5**

10. Correct the adjustable valve arm joints so the rubber grommets can be reconnected to the leveling valve arms at the proper height. Check the rubber components for any tearing or damage, replace as necessary.
11. Connect the rubber grommets to the leveling valve arms.
12. Tighten the clamps on the adjustable valve arm joints with a screwdriver until securely fastened, see Figure 8-3. Remove the dowel from the height control valves.
13. Verify the ride height is correct by performing the Ride Height Inspection as detailed in this section.



## SECTION 9

## Component Replacement

**FASTENERS**

When servicing a vehicle Hendrickson recommends replacing all removed fasteners with new equivalent fasteners. Maintain correct torque values at all times. Check torque values as specified. See Hendrickson's Torque Specifications Section of this publication. If non-Hendrickson fasteners are used follow torque specifications listed in the vehicle manufacturer's service manual.

**AIR SPRING****DISASSEMBLY**

1. Chock the wheels.
2. Support the frame.
3. Disconnect the height control valve's leveling valve arm(s) from the rubber grommet.

**WARNING**

PRIOR TO AND DURING DEFLATION AND INFLATION OF THE AIR SUSPENSION SYSTEM, ENSURE THAT ALL PERSONNEL AND EQUIPMENT ARE CLEAR FROM UNDER THE VEHICLE AND AROUND THE SERVICE AREA, FAILURE TO DO SO CAN CAUSE SERIOUS PERSONAL INJURY, DEATH, OR PROPERTY DAMAGE.

4. See additional Air Spring Cautions and Warnings in the Important Safety Notice Section of this publication prior to deflating or inflating the air system.
5. Lower the height control valve arm(s) to exhaust the air in the air springs and deflate the suspension.

**WARNING**

SOME VEHICLE APPLICATIONS, SUCH AS VEHICLES EQUIPPED WITH OUTRIGGERS, RETAIN SOME AIR PRESSURE IN THE AIR SPRINGS AT ALL TIMES. PRIOR TO PERFORMING ANY MAINTENANCE, SERVICE, OR REPAIR OF THE SUSPENSION, VERIFY EACH AIR SPRING IS COMPLETELY DEFLATED. FAILURE TO DO SO COULD RESULT IN SERIOUS PROPERTY DAMAGE AND/OR SEVERE PERSONAL INJURY.

6. Verify that the air springs are deflated.
7. Remove the lower fasteners that connect the air spring to the axle seat.
8. Remove the air line from the air spring.
9. Remove the brass fittings from the air spring.
10. Remove the upper air spring fasteners that connect the air spring to the inner and outer air spring mounting brackets, see Figure 9-1.
11. Remove the air spring.

**ASSEMBLY**

1. Install the air spring in the upper air spring hanger and reinforcement bracket by inserting air spring studs into the appropriate holes. Attach the fasteners.
2. Install the air spring in the axle seat by inserting the lower air spring stud into the appropriate hole.
3. Install the 1/2" washer and bolt into the axle seat and the locating hole in the bottom of the air spring, see Figure 9-1.
4. Attach the lower 1/2" washer and locknut onto the stud.
5. Tighten the lower 1/2" fasteners to  20-30 foot pounds torque.

7. Install the brass fitting in the air spring using a Teflon thread seal.
8. Connect the air line to the air spring.

**WARNING**

PRIOR TO AND DURING DEFLATION AND INFLATION OF THE AIR SUSPENSION SYSTEM, ENSURE THAT ALL PERSONNEL AND EQUIPMENT ARE CLEAR FROM UNDER THE VEHICLE AND AROUND THE SERVICE AREA, FAILURE TO DO SO CAN CAUSE SERIOUS PERSONAL INJURY, DEATH, OR PROPERTY DAMAGE.

9. See additional Air Spring Cautions and Warnings in the Important Safety Notice Section of this publication prior to deflating or inflating the air system.
10. Inflate the suspension slowly and verify that the air spring bladder inflates uniformly without binding.
11. Reconnect the height control linkage assembly to the height control valve arm.
12. Remove the frame supports.
13. Remove the wheel chocks.
14. Verify the ride height is correct by performing the Ride Height Inspection, see Ride Height in the Alignment & Adjustments Section of this publication.

**FIGURE 9-1**

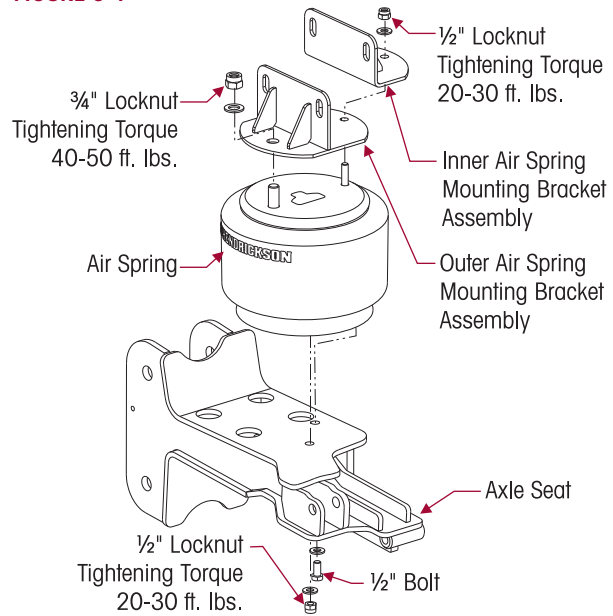

## AIR SPRING FRAME HANGER AND REINFORCEMENT BRACKET

### DISASSEMBLY

1. Chock the wheels.
2. Support the frame.
3. Disconnect the height control valve's leveling valve arm(s) from the rubber grommet.

**WARNING**

PRIOR TO AND DURING DEFLATION AND INFLATION OF THE AIR SUSPENSION SYSTEM, ENSURE THAT ALL PERSONNEL AND EQUIPMENT ARE CLEAR FROM UNDER THE VEHICLE AND AROUND THE SERVICE AREA, FAILURE TO DO SO CAN CAUSE SERIOUS PERSONAL INJURY, DEATH, OR PROPERTY DAMAGE.

4. See additional Air Spring Cautions and Warnings in the Important Safety Notice Section of this publication prior to deflating or inflating the air system.
5. Lower the height control valve arm(s) to exhaust the air in the air springs and deflate the suspension.

**WARNING**

SOME VEHICLE APPLICATIONS, SUCH AS VEHICLES EQUIPPED WITH OUTRIGGERS, RETAIN SOME AIR PRESSURE IN THE AIR SPRINGS AT ALL TIMES. PRIOR TO PERFORMING ANY MAINTENANCE, SERVICE, OR REPAIR OF THE SUSPENSION, VERIFY EACH AIR SPRING IS COMPLETELY DEFLATED. FAILURE TO DO SO COULD RESULT IN SERIOUS PROPERTY DAMAGE AND/OR SEVERE PERSONAL INJURY.



6. Verify that the air springs are deflated.
7. Remove the air line from the air spring.

8. Remove the brass fittings from the air spring.
9. Remove the fasteners that connect the air spring to the inner and outer air spring mounting brackets, see Figure 9-1.
10. Lower the air spring out of the inner and outer air spring mounting brackets.
11. Remove the fasteners that attach the inner and outer air spring mounting brackets to the vehicle.
12. Remove the inner and outer air spring mounting brackets.

### ASSEMBLY

 **WARNING**

FAILURE TO PRESS THE AIR SPRING AGAINST THE UNDERSIDE OF THE FRAME WHILE TIGHTENING THE UPPER AIR SPRING BRACKET CAN RESULT IN COMPONENT DAMAGE AND PERSONAL INJURY OR PROPERTY DAMAGE.

1. Hold the outer air spring mounting bracket tight against the bottom of the frame flange. Install the inner air spring mounting bracket and fasteners. Tighten the fasteners per original equipment manufacturer's specifications.
2. Install the air spring in the inner and outer air spring mounting brackets by inserting the studs into the appropriate holes and attach the fasteners. Tighten the 1/2" fasteners to  20-30 foot pounds torque. Tighten the 3/4" fasteners to  40-50 foot pounds torque, see Figure 9-1.
3. Install the brass fitting in the air spring using a Teflon thread seal.
4. Connect the air line to the air spring.

 **WARNING**

PRIOR TO AND DURING DEFLATION AND INFLATION OF THE AIR SUSPENSION SYSTEM, ENSURE THAT ALL PERSONNEL AND EQUIPMENT ARE CLEAR FROM UNDER THE VEHICLE AND AROUND THE SERVICE AREA, FAILURE TO DO SO CAN CAUSE SERIOUS PERSONAL INJURY, DEATH, OR PROPERTY DAMAGE.

5. See additional Air Spring Cautions and Warnings in the Important Safety Notice Section of this publication prior to deflating or inflating the air system.
6. Inflate the suspension slowly and verify that the air spring bladder inflates uniformly without binding.
7. Reconnect the height control linkage assembly to the height control valve arm.
8. Remove the frame supports.
9. Remove the wheel chocks.
10. Verify the ride height is correct by performing a ride height inspection, refer to the Alignment & Adjustments Section of this publication.

## HEIGHT CONTROL VALVE

### DISASSEMBLY

1. Chock the wheels.
2. Support the frame.
3. Disconnect the height control valve's leveling valve arm(s) from the rubber grommet.

**WARNING**

PRIOR TO AND DURING DEFLATION AND INFLATION OF THE AIR SUSPENSION SYSTEM, ENSURE THAT ALL PERSONNEL AND EQUIPMENT ARE CLEAR FROM UNDER THE VEHICLE AND AROUND THE SERVICE AREA, FAILURE TO DO SO CAN CAUSE SERIOUS PERSONAL INJURY, DEATH, OR PROPERTY DAMAGE.

4. See additional Air Spring Cautions and Warnings in the Important Safety Notice Section of this publication prior to deflating or inflating the air system.
5. Lower the height control valve arm(s) to exhaust the air in the air springs and deflate the suspension.

**WARNING**

SOME VEHICLE APPLICATIONS, SUCH AS VEHICLES EQUIPPED WITH OUTRIGGERS, RETAIN SOME AIR PRESSURE IN THE AIR SPRINGS AT ALL TIMES. PRIOR TO PERFORMING ANY MAINTENANCE, SERVICE, OR REPAIR OF THE SUSPENSION, VERIFY EACH AIR SPRING IS COMPLETELY DEFLATED. FAILURE TO DO SO COULD RESULT IN SERIOUS PROPERTY DAMAGE AND/OR SEVERE PERSONAL INJURY.

6. Verify that the air springs are deflated.
7. Remove the  $\frac{5}{16}$ " fasteners that attach the linkage assembly to the height control valve arm, see Figure 9-2.
8. Remove the air lines from the height control valve.
9. Remove the brass fittings from the height control valve.
10. Remove the  $\frac{1}{4}$ " fasteners that attach the height control valve mounting bracket to the frame rail.
11. Remove the height control valve and mounting bracket.

**FIGURE 9-2**

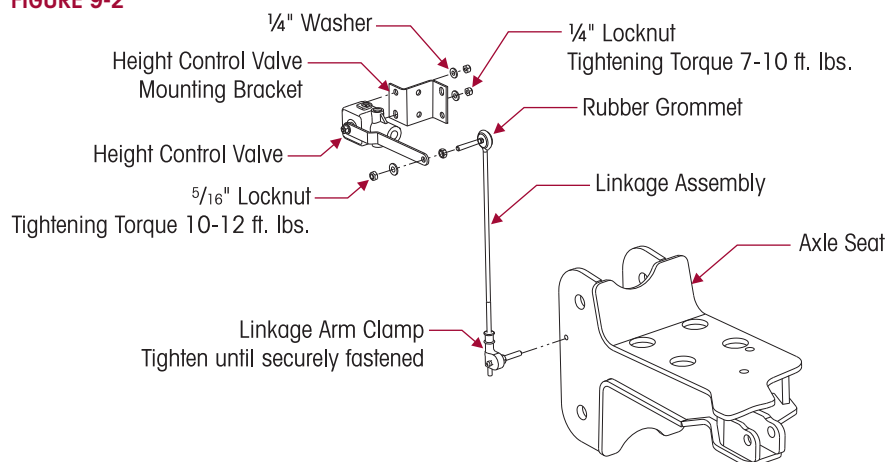

### ASSEMBLY

1. Install the height control valve to the frame rail. Attach the 1/4" fasteners and tighten to 7-10 foot pounds torque, see Figure 9-2.
2. Install brass fittings into height control valve using Teflon thread seal.
3. Install air lines to height control valve.
4. Install the linkage assembly to the height control valve arm. Attach the 5/16" fasteners and tighten to 10-12 foot pounds torque.

### WARNING

PRIOR TO AND DURING DEFLATION AND INFLATION OF THE AIR SUSPENSION SYSTEM, ENSURE THAT ALL PERSONNEL AND EQUIPMENT ARE CLEAR FROM UNDER THE VEHICLE AND AROUND THE SERVICE AREA, FAILURE TO DO SO CAN CAUSE SERIOUS PERSONAL INJURY, DEATH, OR PROPERTY DAMAGE.

5. See additional Air Spring Cautions and Warnings in the Important Safety Notice Section of this publication prior to deflating or inflating the air system.
6. Inflate the suspension slowly and verify that the air spring bladder inflates uniformly without binding.
7. Reconnect the height control linkage assembly to the height control valve arm.
8. Remove the frame supports.
9. Remove the wheel chocks.
10. Verify the ride height is correct by performing a ride height inspection, refer to the Alignment & Adjustments Section of this publication.

### SHOCK ABSORBER

#### DISASSEMBLY

1. Remove the fasteners that connect the shock absorber to the upper shock mount.
2. Remove the fasteners that connect the shock absorber to the axle seat.
3. Remove the shock absorber.

#### ASSEMBLY

1. Install the shock absorber to the upper shock mount stud. Attach the 3/4" upper shock fasteners (only one washer needed on the upper shock mount, located on the outboard side of the upper shock absorber), tighten to 175-200 foot pounds torque.
2. Install the lower shock absorber to the axle seat. Attach the 3/4" lower shock fasteners and tighten to 225-255 foot pounds torque, see Figure 9-3.

**FIGURE 9-3**

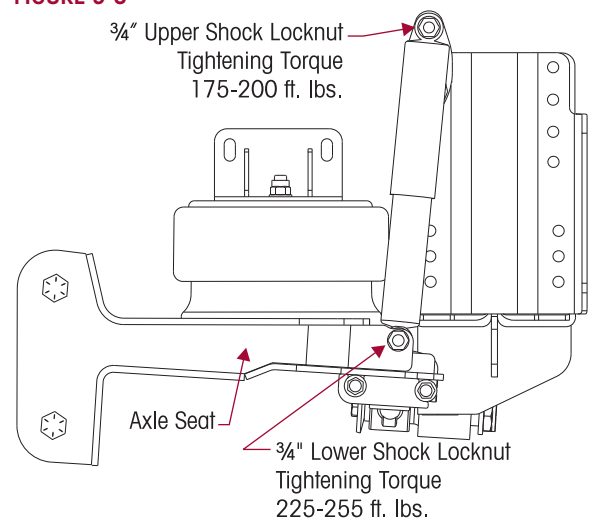

## TRANSVERSE TORQUE ROD

### DISASSEMBLY

1. Chock the wheels.
2. Support the frame.
3. Disconnect the height control valve's leveling valve arm(s) from the rubber grommet.

**WARNING**

PRIOR TO AND DURING DEFLATION AND INFLATION OF THE AIR SUSPENSION SYSTEM, ENSURE THAT ALL PERSONNEL AND EQUIPMENT ARE CLEAR FROM UNDER THE VEHICLE AND AROUND THE SERVICE AREA, FAILURE TO DO SO CAN CAUSE SERIOUS PERSONAL INJURY, DEATH, OR PROPERTY DAMAGE.

4. See additional Air Spring Cautions and Warnings in the Important Safety Notice Section of this publication prior to deflating or inflating the air system.
5. Lower the height control valve arm(s) to exhaust the air in the air springs and deflate the suspension.

**FIGURE 9-4 Twin Steer Forward Front and Single Steer**

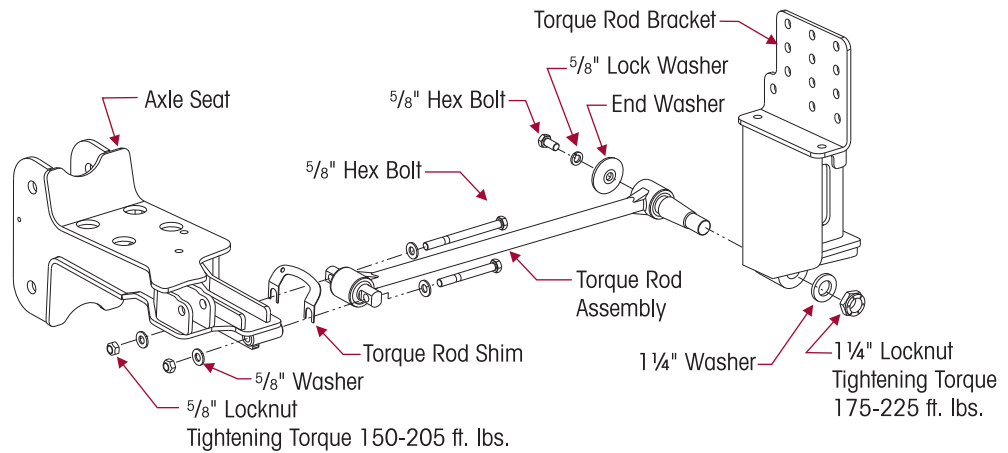

**FIGURE 9-5 Twin Steer Forward Rear**

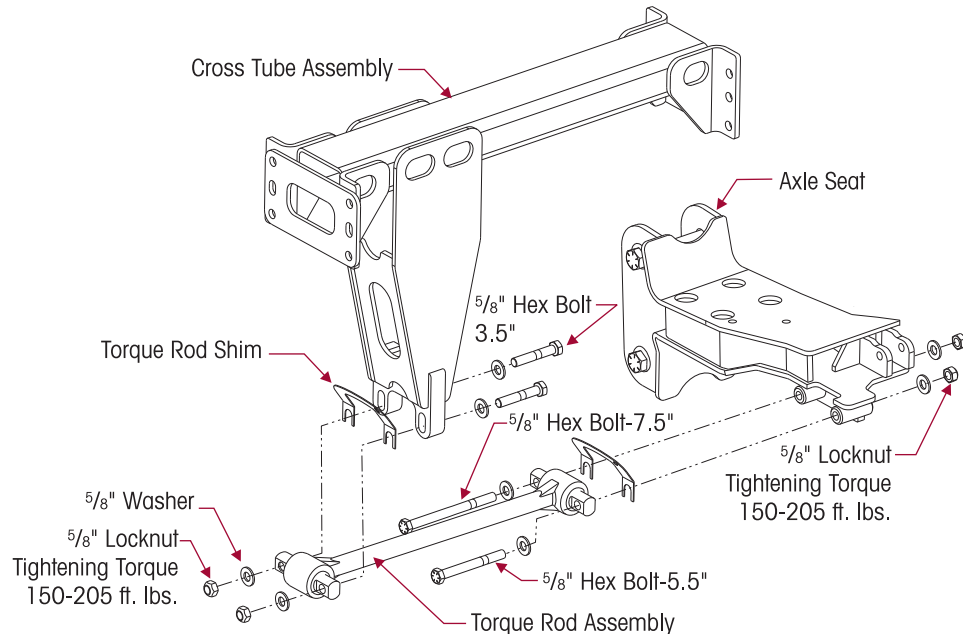

**WARNING**

SOME VEHICLE APPLICATIONS, SUCH AS VEHICLES EQUIPPED WITH OUTRIGGERS, RETAIN SOME AIR PRESSURE IN THE AIR SPRINGS AT ALL TIMES. PRIOR TO PERFORMING ANY MAINTENANCE, SERVICE, OR REPAIR OF THE SUSPENSION, VERIFY EACH AIR SPRING IS COMPLETELY DEFLATED. FAILURE TO DO SO COULD RESULT IN SERIOUS PROPERTY DAMAGE AND/OR SEVERE PERSONAL INJURY.

6. Verify that the air springs are deflated.

**SERVICE HINT**

Note the quantity and location of shims removed to maintain the lateral alignment of the axle during the assembly. See Alignment & Adjustments Section of this publication.

7. Remove the torque rod attaching fasteners, see Figures 9-4 and 9-5.

**ASSEMBLY**

1. Install the transverse torque rod, any shims that were removed during disassembly and attaching fasteners. Tighten torque rod attaching fasteners, see Figures 9-4 and 9-5.
  - 5/8" locknuts to 150-205 foot pounds torque
  - 1 1/4" locknuts to 175-225 foot pounds torque

**WARNING**

PRIOR TO AND DURING DEFLATION AND INFLATION OF THE AIR SUSPENSION SYSTEM, ENSURE THAT ALL PERSONNEL AND EQUIPMENT ARE CLEAR FROM UNDER THE VEHICLE AND AROUND THE SERVICE AREA, FAILURE TO DO SO CAN CAUSE SERIOUS PERSONAL INJURY, DEATH, OR PROPERTY DAMAGE.

2. See additional Air Spring Cautions and Warnings in the Important Safety Notice Section of this publication prior to deflating or inflating the air system.
3. Inflate the suspension slowly and verify that the air spring bladder inflates uniformly without binding.
4. Reconnect the height control linkage assembly to the height control valve arm.
5. Remove the frame supports.
6. Remove the wheel chocks.
7. Verify the ride height is correct by performing a ride height inspection, refer to the Alignment & Adjustments Section of this publication.

**TRANSVERSE TORQUE ROD BUSHING****DISASSEMBLY****CAUTION**

DO NOT USE HEAT OR USE A CUTTING TORCH TO REMOVE THE BUSHINGS FROM THE TORQUE ROD. THE USE OF HEAT WILL ADVERSELY AFFECT THE STRENGTH OF THE TORQUE ROD.

You will need:

- A vertical shop press with a capacity of at least 10 tons
  - A receiving tool (5" long, 2" I.D. by 1/4" wall steel tubing), see Special Tools Section of this publication for shop made tool specifications.
1. Remove torque rods from suspension as detailed in the Component Replacement Section of this publication.
  2. Support the torque rod end on the receiving tool with the end tube of the torque rod centered on the tool. Be sure the torque rod is squarely supported on the press bed for safety.
  3. Push directly on the bushing straddle mount bar pin until the top of the bushing is level with the top of torque rod end tube. Press until the bushing clears the torque rod end tube.
  4. Clean and inspect the inner diameter of the torque rod ends, removing any nicks with an emery cloth or a rotary sander, see Figure 9-6.

FIGURE 9-6



FIGURE 9-7



**ASSEMBLY**

**NOTE**

**DO NOT** use a petroleum or soap base lubricant. Such lubricants can cause adverse reactions with the bushing, such as deterioration of the rubber, causing premature failure.

1. Lubricate the inner diameter of the torque rod ends and the new rubber bushings with a vegetable base oil (cooking oil), see Figure 9-7.
2. Press in the new bushings. Support the torque rod end on the receiving tool with the end tube of torque rod centered on the receiving tool. The straddle mount bar pin bushings must have the mounting flats positioned at 90° degrees to shank of the torque rod, see Figure 9-8.

FIGURE 9-8

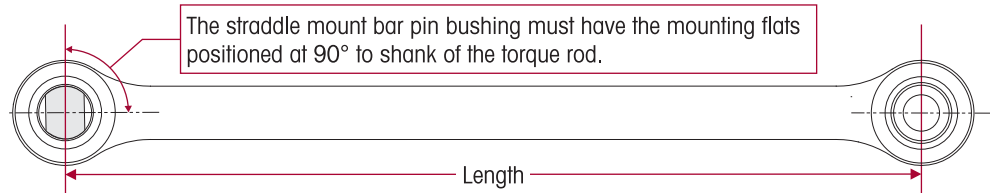

3. Press directly on the straddle mount bar pin of bushing. The rubber bushings of the bar pin must be centered within the torque rod end tubes.
4. When pressing in the new bushings, overshoot the desired final position by approximately  $\frac{3}{16}$ " , see Figure 9-9.
5. Press the bushing again from opposite side to center the bar pin within the torque rod end, see Figure 9-10.

FIGURE 9-9



FIGURE 9-10



6. Wipe off excess lubricant. Allow the lubricant four (4) hours to dissipate before operating the vehicle.

**CAUTION**

IF THE TORQUE ROD ASSEMBLY IS NOT ALLOWED THE ALLOTTED TIME FOR THE LUBRICANT TO DISSIPATE, THE BUSHING MAY SLIDE FROM THE TORQUE ROD END TUBE. THE BUSHING WILL THEN NEED TO BE REMOVED AND A NEW BUSHING RE-INSTALLED.

7. Install the transverse torque rod assembly as detailed in the Component Replacement Section of this publication.



## BEAM ASSEMBLY AND THRUST WASHERS

### SERVICE HINT

Remove and replace the beams on one side of the suspension at a time. The other beams that are still connected will maintain control of the axle during service. If all four beams are removed at the same time, provisions for axle control, such as jack stands or floor jacks, must be used.

### HENDRICKSON RECOMMENDS THE FOLLOWING WHEN SERVICING:

### NOTE

If one bushing or thrust washer in a beam assembly requires replacement, Hendrickson recommends all bushings and all thrust washers be replaced.

### DISASSEMBLY

1. Chock the wheels.
2. Support the frame at ride height.
3. Disconnect the height control valve's leveling valve arm(s) from the rubber grommet.



### WARNING

PRIOR TO AND DURING DEFLATION AND INFLATION OF THE AIR SUSPENSION SYSTEM, ENSURE THAT ALL PERSONNEL AND EQUIPMENT ARE CLEAR FROM UNDER THE VEHICLE AND AROUND THE SERVICE AREA, FAILURE TO DO SO CAN CAUSE SERIOUS PERSONAL INJURY, DEATH, OR PROPERTY DAMAGE.

4. See additional Air Spring Cautions and Warnings in the Important Safety Notice Section of this publication prior to deflating or inflating the air system.
5. Lower the height control valve arm(s) to exhaust the air in the air springs and deflate the suspension.



### WARNING

SOME VEHICLE APPLICATIONS, SUCH AS VEHICLES EQUIPPED WITH OUTRIGGERS, RETAIN SOME AIR PRESSURE IN THE AIR SPRINGS AT ALL TIMES. PRIOR TO PERFORMING ANY MAINTENANCE, SERVICE, OR REPAIR OF THE SUSPENSION, VERIFY EACH AIR SPRING IS COMPLETELY DEFLATED. FAILURE TO DO SO COULD RESULT IN SERIOUS PROPERTY DAMAGE AND/OR SEVERE PERSONAL INJURY.

6. Verify that the air springs are deflated.
7. Loosen all pivot bolt fasteners on the axle being serviced. **DO NOT** remove at this time.

### SERVICE HINT

Remove and replace the beams on one side of the suspension at a time. The other beams that are still connected will maintain control of the axle during service. If all four beams are removed at the same time provisions for axle control, such as jack stands or floor jacks, must be used.

8. Remove the pivot bolt fasteners on one of the lower beam assemblies.
9. Remove the beam assembly from the axle seat and then from the frame hanger.
10. Remove the pivot bolt fasteners from the mating upper beam assembly.
11. Remove the beam assembly from the axle seat and then from the frame hanger.
12. Service the removed beams and re-assemble to the suspension before removing the beams on the opposite side of the suspension.

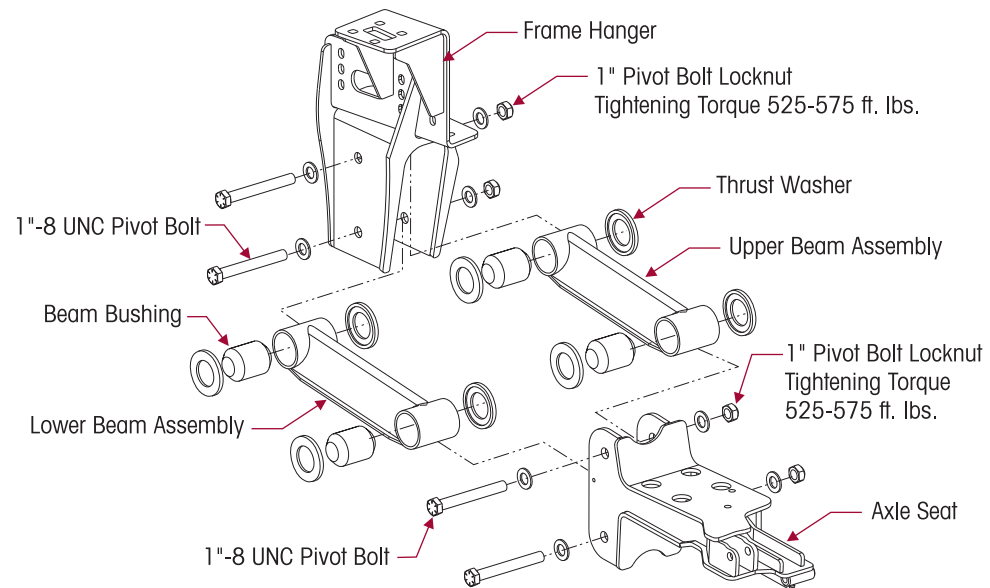
**FIGURE 9-11 Upper and Lower Beam Assembly****ASSEMBLY**

1. Attach thrust washers to beam assemblies.
2. Install upper beam assembly and pivot bolt fasteners. Verify the beam assembly is installed with the narrow end of the beam facing up, refer to Figure 9-11. Snug, **DO NOT** tighten pivot bolt fasteners at this time.
3. Install lower beam assembly and pivot bolt fasteners. Verify the beam assembly is installed with the narrow end of the beam facing up, refer to Figure 9-11. Snug, **DO NOT** tighten pivot bolt fasteners at this time.
4. Repeat steps 8 through 12 of the beam disassembly procedure for the remaining beams assemblies.
5. After all beam assemblies are installed, tighten the pivot fasteners to 525-575 foot pounds.

**WARNING**

PRIOR TO AND DURING DEFLATION AND INFLATION OF THE AIR SUSPENSION SYSTEM, ENSURE THAT ALL PERSONNEL AND EQUIPMENT ARE CLEAR FROM UNDER THE VEHICLE AND AROUND THE SERVICE AREA, FAILURE TO DO SO CAN CAUSE SERIOUS PERSONAL INJURY, DEATH, OR PROPERTY DAMAGE.

6. See additional Air Spring Cautions and Warnings in the Important Safety Notice Section of this publication prior to deflating or inflating the air system.
7. Inflate the suspension slowly and verify that the air spring bladder inflates uniformly without binding.
8. Reconnect the height control linkage assembly to the height control valve arm.
9. Remove the frame supports.
10. Remove the wheel chocks.
11. Verify the ride height is correct by performing a ride height inspection, refer to the Alignment & Adjustments Section of this publication.

## BEAM ASSEMBLY RUBBER BUSHINGS

### DISASSEMBLY

You will need:

- A vertical shop press with a capacity of at least 10 tons
- A receiving tool (5" long, 3.5" I.D. by ¼" wall steel tubing), see the Special Tools Section of this publication for shop made tool specifications.

**FIGURE 9-12**

1. Remove the beam assembly and thrust washers as detailed in the Beam Assembly and Thrust Washer in this section.
2. Support the beam assembly end hub centered on the receiving tool.
2. Press out the old bushing. Press directly on the bushing inner metal until the bushing clears the beam end hub, (these bushings are not cartridge type bushings and do not have outer metals), see Figure 9-12.
3. Clean and inspect the I.D. of beam end hub removing any nicks with emery cloth or rotary sander.

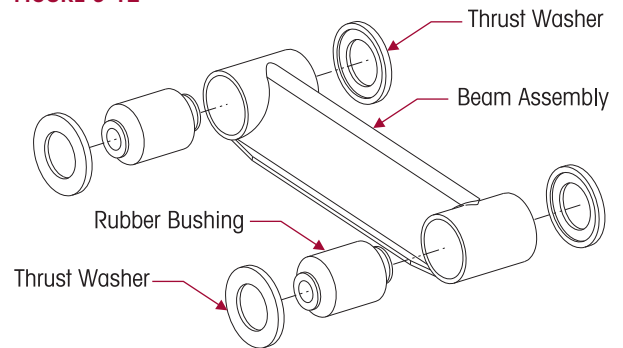

### ASSEMBLY

#### NOTE

**DO NOT** use a petroleum or soap base lubricant. Such lubricants can cause adverse reactions with the bushing, such as deterioration of the rubber, causing premature failure.

1. Lubricate the I.D. of beam end hub and the new rubber bushings with vegetable base oil (cooking oil). **DO NOT** use petroleum or soap base lubricant.
2. Support the beam end hub centered on the receiving tool.
3. Press in the new bushings. Press directly on the inner metal of bushing. Bushings must be centered within the beam end hub. When pressing in the new bushings, overshoot desired final position by ⅜" and press the bushing again from opposite side to center the bushing within beam end hub.
4. Install the beam assemblies; see Beam Assembly in this section.

### CROSS MEMBER

#### WARNING

DO NOT USE THE CROSS MEMBER FOR JACKING OR AS A SUPPORT POINT FOR SERVICING THE VEHICLE.

IMPROPER JACKING AND SUPPORT METHODS WILL VOID HENDRICKSON'S WARRANTY AND CAN CAUSE STRUCTURAL DAMAGE THAT RESULT IN LOSS OF VEHICLE CONTROL, SEVERE PERSONAL INJURY OR DEATH. REFER TO THE VEHICLE MANUFACTURER FOR PROPER JACKING AND SUPPORT METHODS.

### DISASSEMBLY

1. Chock the wheels.
2. Support the frame.
3. Disconnect the height control valve's leveling valve arm(s) from the rubber grommet.

**WARNING**

PRIOR TO AND DURING DEFLATION AND INFLATION OF THE AIR SUSPENSION SYSTEM, ENSURE THAT ALL PERSONNEL AND EQUIPMENT ARE CLEAR FROM UNDER THE VEHICLE AND AROUND THE SERVICE AREA, FAILURE TO DO SO CAN CAUSE SERIOUS PERSONAL INJURY, DEATH, OR PROPERTY DAMAGE.

- See additional Air Spring Cautions and Warnings in the Important Safety Notice Section of this publication prior to deflating or inflating the air system.
- Lower the height control valve arm(s) to exhaust the air in the air springs and deflate the suspension.

**WARNING**

SOME VEHICLE APPLICATIONS, SUCH AS VEHICLES EQUIPPED WITH OUTRIGGERS, RETAIN SOME AIR PRESSURE IN THE AIR SPRINGS AT ALL TIMES. PRIOR TO PERFORMING ANY MAINTENANCE, SERVICE, OR REPAIR OF THE SUSPENSION, VERIFY EACH AIR SPRING IS COMPLETELY DEFLATED. FAILURE TO DO SO COULD RESULT IN SERIOUS PROPERTY DAMAGE AND/OR SEVERE PERSONAL INJURY.

- Verify that the air springs are deflated.
- Remove the beam assemblies, see Beam Assembly in this section.
- Remove the fasteners that connect the cross member to frame hangers, see Figure 9-13.

**FIGURE 9-13**

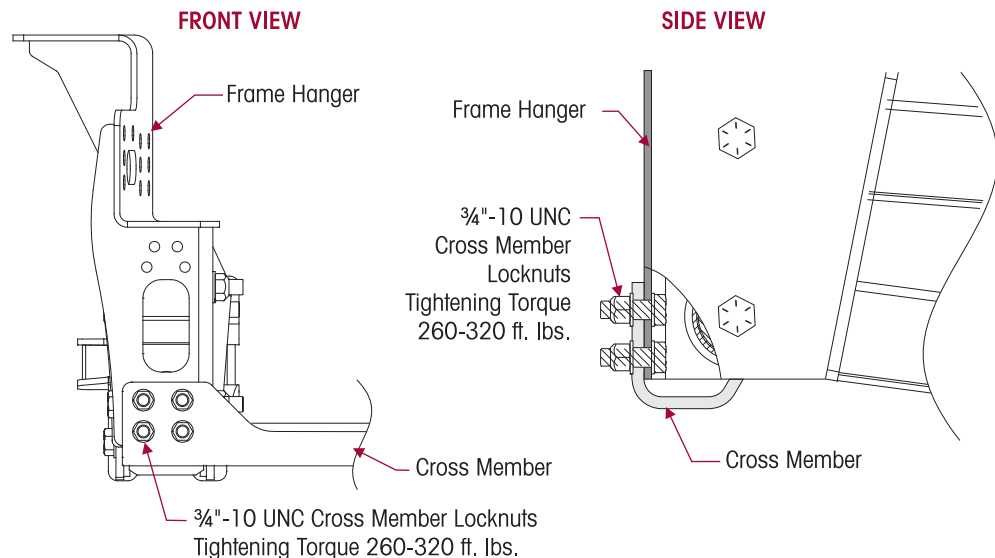

**ASSEMBLY**

- Position the cross member against the frame hanger, see Figure 9-13.
- Install the cross member fasteners through the frame hanger, then through the cross member. Verify the fastener heads are on the inside of the frame hanger.
- Tighten the cross member fasteners to 260-320 foot pounds.
- Attach beam assemblies, refer to Beam Assembly in this section.

**WARNING**

PRIOR TO AND DURING DEFLATION AND INFLATION OF THE AIR SUSPENSION SYSTEM, ENSURE THAT ALL PERSONNEL AND EQUIPMENT ARE CLEAR FROM UNDER THE VEHICLE AND AROUND THE SERVICE AREA, FAILURE TO DO SO CAN CAUSE SERIOUS PERSONAL INJURY, DEATH, OR PROPERTY DAMAGE.

- See additional Air Spring Cautions and Warnings in the Important Safety Notice Section of this publication prior to deflating or inflating the air system.
- Inflate the suspension slowly and verify that the air spring bladder inflates uniformly without binding.
- Reconnect the height control linkage assembly to the height control valve arm.

8. Remove the frame supports.
9. Remove the wheel chocks.
10. Verify the ride height is correct by performing a ride height inspection, refer to the Alignment & Adjustments Section of this publication.

## CROSS CHANNEL PLATE

**WARNING**

DO NOT USE THE CROSS CHANNEL PLATE FOR JACKING OR AS A SUPPORT POINT FOR SERVICING THE VEHICLE.

IMPROPER JACKING AND SUPPORT METHODS WILL VOID HENDRICKSON'S WARRANTY AND CAN CAUSE STRUCTURAL DAMAGE THAT RESULT IN LOSS OF VEHICLE CONTROL, SEVERE PERSONAL INJURY OR DEATH. REFER TO THE VEHICLE MANUFACTURER FOR PROPER JACKING AND SUPPORT METHODS.

**FIGURE 9-14**

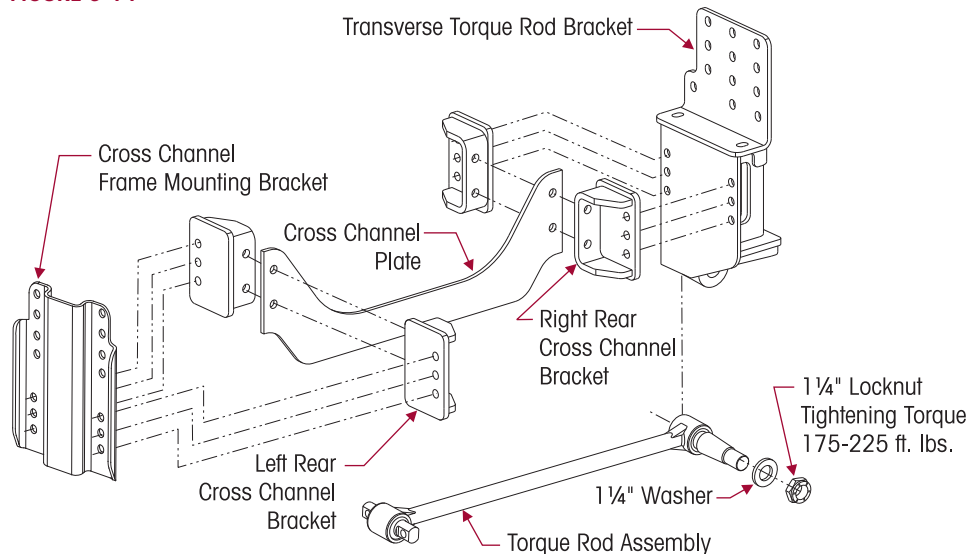

### DISASSEMBLY

1. Chock the wheels.
2. Support the frame.
3. Disconnect the height control valve's leveling valve arm(s) from the rubber grommet.

**WARNING**

PRIOR TO AND DURING DEFLATION AND INFLATION OF THE AIR SUSPENSION SYSTEM, ENSURE THAT ALL PERSONNEL AND EQUIPMENT ARE CLEAR FROM UNDER THE VEHICLE AND AROUND THE SERVICE AREA, FAILURE TO DO SO CAN CAUSE SERIOUS PERSONAL INJURY, DEATH, OR PROPERTY DAMAGE.

4. See additional Air Spring Cautions and Warnings in the Important Safety Notice Section of this publication prior to deflating or inflating the air system.
5. Lower the height control valve arm(s) to exhaust the air in the air springs and deflate the suspension.

**WARNING**

SOME VEHICLE APPLICATIONS, SUCH AS VEHICLES EQUIPPED WITH OUTRIGGERS, RETAIN SOME AIR PRESSURE IN THE AIR SPRINGS AT ALL TIMES. PRIOR TO PERFORMING ANY MAINTENANCE, SERVICE, OR REPAIR OF THE SUSPENSION, VERIFY EACH AIR SPRING IS COMPLETELY DEFLATED. FAILURE TO DO SO COULD RESULT IN SERIOUS PROPERTY DAMAGE AND/OR SEVERE PERSONAL INJURY.

6. Verify that the air springs are deflated.
7. Remove the fasteners that attach the cross channel brackets and cross channel plate per vehicle manufacturer's specifications.

8. Remove the fasteners that attach the left-rear cross channel bracket to the cross channel frame mounting bracket per vehicle manufacturer's specifications.
9. Remove the fasteners attach the right-rear cross channel bracket to the transverse torque rod bracket per vehicle manufacturer's specifications.
10. Remove the cross channel plate.

### ASSEMBLY

1. Install the left-rear cross channel bracket and fasteners to the cross channel frame mounting bracket. Snug, **DO NOT** tighten fasteners at this time.
2. Install the right-rear cross channel bracket and fasteners to the transverse torque rod bracket. Snug, **DO NOT** tighten fasteners at this time.
3. Install the cross channel plate between the cross channel brackets on both sides of the vehicle.
4. Install the cross channel plate fasteners through the cross channel brackets and cross channel plate on both sides of the vehicle.
5. Tighten the cross channel plate fasteners to vehicle manufacturer's specifications.
6. Tighten the cross channel bracket fasteners to vehicle manufacturer's specifications.
7. Remove the frame supports and lower the vehicle.



### WARNING

PRIOR TO AND DURING DEFLATION AND INFLATION OF THE AIR SUSPENSION SYSTEM, ENSURE THAT ALL PERSONNEL AND EQUIPMENT ARE CLEAR FROM UNDER THE VEHICLE AND AROUND THE SERVICE AREA, FAILURE TO DO SO CAN CAUSE SERIOUS PERSONAL INJURY, DEATH, OR PROPERTY DAMAGE.

8. See additional Air Spring Cautions and Warnings in the Important Safety Notice Section of this publication prior to deflating or inflating the air system.
9. Inflate the suspension slowly and verify that the air spring bladder inflates uniformly without binding.
10. Reconnect the height control linkage assembly to the height control valve arm.
11. Remove the frame supports.
12. Remove the wheel chocks.
13. Verify the ride height is correct by performing a ride height inspection, refer to the Alignment & Adjustments Section of this publication.

## CROSS TUBE ASSEMBLY

 **WARNING**

DO NOT USE THE CROSS TUBE ASSEMBLY FOR JACKING OR AS A SUPPORT POINT FOR SERVICING THE VEHICLE.

IMPROPER JACKING AND SUPPORT METHODS WILL VOID HENDRICKSON'S WARRANTY AND CAN CAUSE STRUCTURAL DAMAGE THAT RESULT IN LOSS OF VEHICLE CONTROL, SEVERE PERSONAL INJURY OR DEATH. REFER TO THE VEHICLE MANUFACTURER FOR PROPER JACKING AND SUPPORT METHODS.

### DISASSEMBLY

**NOTE**

The cross tube assembly is a one piece fabricated assembly. Removal or installation requires spreading the frame rails apart so the cross tube assembly can pass by the lower frame flange. Refer to the vehicle manufacturer for instructions on spreading the frame rails.

1. Chock the wheels.
2. Support the frame.
3. Disconnect the height control valve's leveling valve arm(s) from the rubber grommet.

 **WARNING**

PRIOR TO AND DURING DEFLATION AND INFLATION OF THE AIR SUSPENSION SYSTEM, ENSURE THAT ALL PERSONNEL AND EQUIPMENT ARE CLEAR FROM UNDER THE VEHICLE AND AROUND THE SERVICE AREA, FAILURE TO DO SO CAN CAUSE SERIOUS PERSONAL INJURY, DEATH, OR PROPERTY DAMAGE.

4. See additional Air Spring Cautions and Warnings in the Important Safety Notice Section of this publication prior to deflating or inflating the air system.
5. Lower the height control valve arm(s) to exhaust the air in the air springs and deflate the suspension.

 **WARNING**

SOME VEHICLE APPLICATIONS, SUCH AS VEHICLES EQUIPPED WITH OUTRIGGERS, RETAIN SOME AIR PRESSURE IN THE AIR SPRINGS AT ALL TIMES. PRIOR TO PERFORMING ANY MAINTENANCE, SERVICE, OR REPAIR OF THE SUSPENSION, VERIFY EACH AIR SPRING IS COMPLETELY DEFLATED. FAILURE TO DO SO COULD RESULT IN SERIOUS PROPERTY DAMAGE AND/OR SEVERE PERSONAL INJURY.

6. Verify that the air springs are deflated.

**SERVICE HINT**

Note the quantity and location of shims removed to maintain the lateral alignment of the axle during assembly. See the Alignment & Adjustments Section of this publication.

7. Remove the fasteners that attach the transverse torque rod to the cross tube assembly and to the axle seat. Note the quantity and location of shims removed.
8. Remove the transverse torque rod, see Figure 9-15.
9. Remove the fasteners that attach the cross tube assembly to frame rail.

**NOTE**

The cross tube assembly is a one piece fabricated assembly. Removal or installation requires spreading the frame rails apart so the cross tube assembly can pass by the lower frame flange. Refer to the vehicle manufacturer for instructions on spreading the frame rails.

10. Remove the cross tube assembly and cross tube frame brackets.

### ASSEMBLY

**NOTE**

The cross tube assembly is a one piece fabricated assembly. Removal or installation requires spreading the frame rails apart so the cross tube assembly can pass by the lower frame flange. Refer to the vehicle manufacturer for instructions on spreading the frame rails.

1. Position the cross tube assembly between the frame rails.
2. Position the cross tube frame brackets on the outboard side of the frame rails

**FIGURE 9-15** Twin Steer Forward Rear

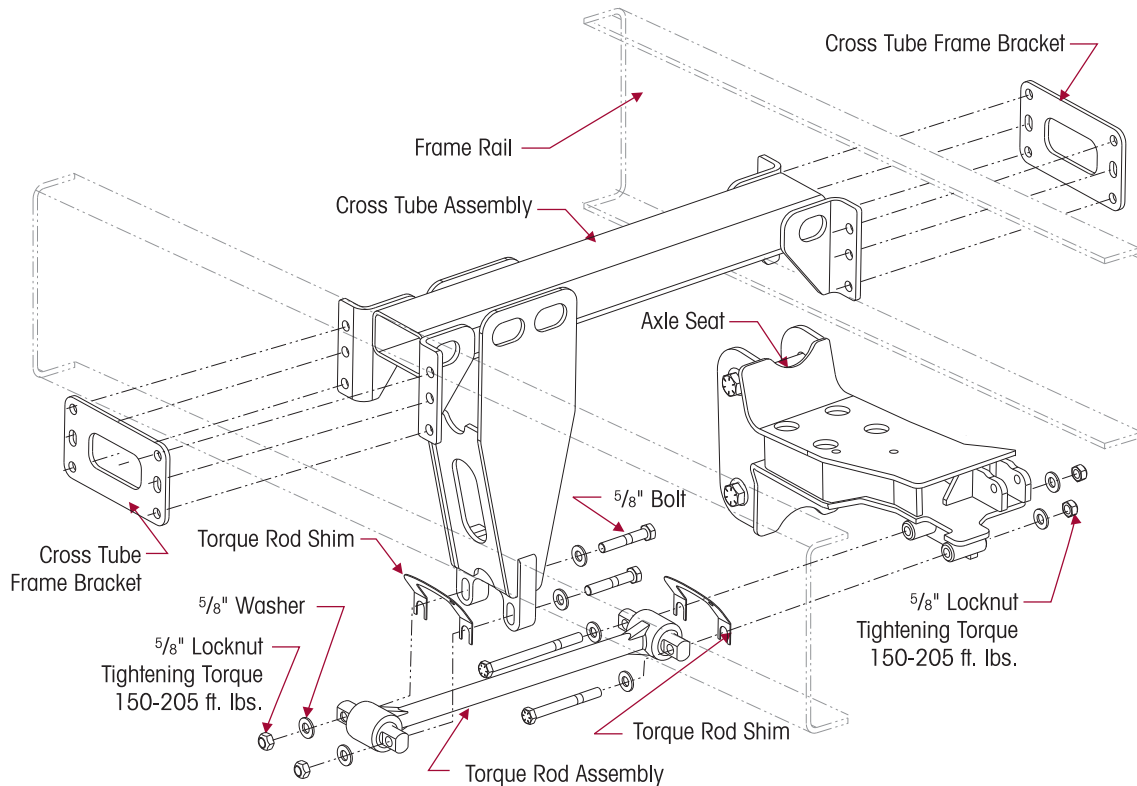

3. Install fasteners through the cross tube frame brackets, frame rail, and cross tube assembly on each side of the vehicle, see Figure 9-15.
4. Tighten frame fasteners per the vehicle manufacturer's specifications.

**NOTE**

Hendrickson recommends using Grade 8 bolts, Grade C locknuts and hardened washers for all torque rod attachments.

5. Install the transverse torque rod, torque rod fasteners, and any shims that were removed.

**SERVICE HINT**

Note the quantity and location of shims removed to maintain the lateral alignment of the axle during assembly. See Alignment & Adjustments Section of this publication.

6. Tighten the torque rod fasteners to 150-205 foot pounds.



**WARNING**

PRIOR TO AND DURING DEFLATION AND INFLATION OF THE AIR SUSPENSION SYSTEM, ENSURE THAT ALL PERSONNEL AND EQUIPMENT ARE CLEAR FROM UNDER THE VEHICLE AND AROUND THE SERVICE AREA, FAILURE TO DO SO CAN CAUSE SERIOUS PERSONAL INJURY, DEATH, OR PROPERTY DAMAGE.

7. See additional Air Spring Cautions and Warnings in the Important Safety Notice Section of this publication prior to deflating or inflating the air system.
8. Inflate the suspension slowly and verify that the air spring bladder inflates uniformly without binding.
9. Reconnect the height control linkage assembly to the height control valve arm.
10. Remove the frame supports.
11. Remove the wheel chocks.
12. Verify the ride height is correct by performing a ride height inspection, refer to the Alignment & Adjustments section of this publication.
13. Verify lateral alignment is within the vehicle manufacturer's specifications.



## AXLE SEAT

### DISASSEMBLY

1. Chock the wheels.
2. Support the frame.
3. Disconnect the height control valve's leveling valve arm(s) from the rubber grommet.

 **WARNING**

PRIOR TO AND DURING DEFLATION AND INFLATION OF THE AIR SUSPENSION SYSTEM, ENSURE THAT ALL PERSONNEL AND EQUIPMENT ARE CLEAR FROM UNDER THE VEHICLE AND AROUND THE SERVICE AREA, FAILURE TO DO SO CAN CAUSE SERIOUS PERSONAL INJURY, DEATH, OR PROPERTY DAMAGE.



4. See additional Air Spring Cautions and Warnings in the Important Safety Notice Section of this publication prior to deflating or inflating the air system.
5. Lower the height control valve arm(s) to exhaust the air in the air springs and deflate the suspension.

 **WARNING**

SOME VEHICLE APPLICATIONS, SUCH AS VEHICLES EQUIPPED WITH OUTRIGGERS, RETAIN SOME AIR PRESSURE IN THE AIR SPRINGS AT ALL TIMES. PRIOR TO PERFORMING ANY MAINTENANCE, SERVICE, OR REPAIR OF THE SUSPENSION, VERIFY EACH AIR SPRING IS COMPLETELY DEFLATED. FAILURE TO DO SO COULD RESULT IN SERIOUS PROPERTY DAMAGE AND/OR SEVERE PERSONAL INJURY.

6. Verify that the air springs are deflated.
7. Remove the beam assemblies, see Beam Assembly and Thrust Washers, Disassembly in this section.
8. Remove the  $\frac{5}{16}$ " fasteners that attach the height control valve extension rod to the axle seat, see Figure 9-16.
9. Remove the  $\frac{1}{2}$ " fasteners that attach the air spring to the axle seat, and raise the air spring out of the axle seat.
10. Remove the  $\frac{3}{4}$ " lower shock fasteners that attach to the axle seat, and raise the shock absorber out of the axle seat.
11. Remove the transverse torque rod if transverse torque rod is attached to axle seat being serviced. See transverse torque rod disassembly in this section.
12. Remove the fasteners that attach the axle seat to the axle.
13. Remove the axle seat.

### ASSEMBLY

1. Install the axle seat to the axle. Install the axle seat fasteners through the axle seat and axle. Tighten the axle seat fasteners per the vehicle manufacturer's specifications.
2. Install the beam assemblies, see Beam Assembly and Thrust Washers, Assembly in this section.
3. Install the air spring in axle seat. Attach  $\frac{1}{2}$ " fasteners to stud and tighten to  20-30 foot pounds torque.
4. Install the shock absorber to axle seat. Attach  $\frac{3}{4}$ " lower shock fasteners and tighten to  225-255 foot pounds torque, see Figures 9-16 and 9-17.
5. Install the transverse torque rod and any shims that were removed, see transverse torque rod assembly in this section.
6. Install the height control valve extension rod to axle seat, see Figures 9-16 and 9-17. Attach  $\frac{5}{16}$ " fasteners and tighten to  10-12 foot pounds torque.

**FIGURE 9-16 Twin Steer Forward Front and Single Steer**

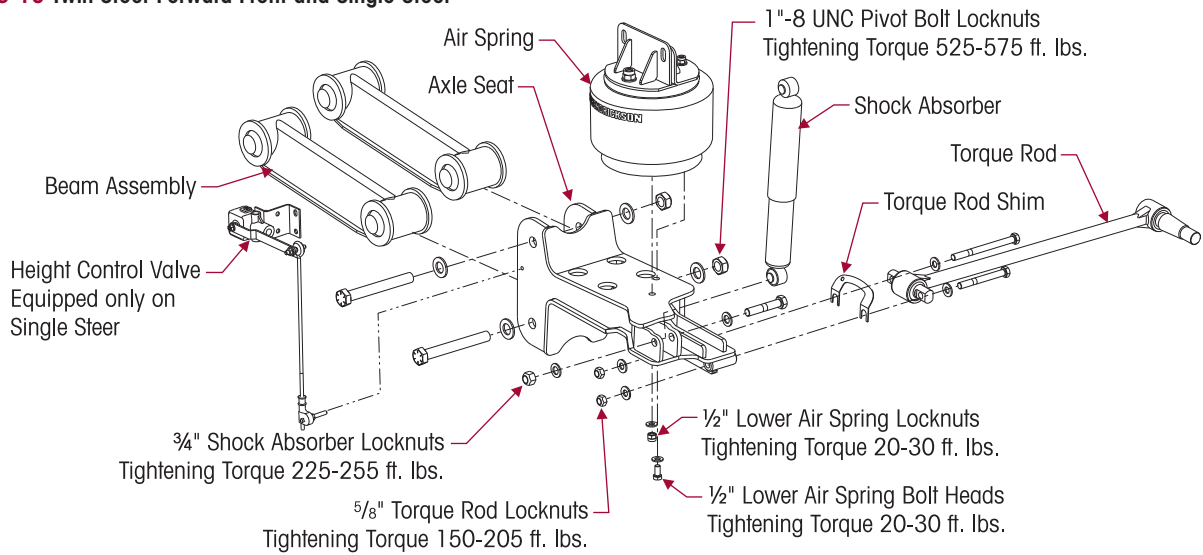

**FIGURE 9-17 Twin Steer Forward Rear**

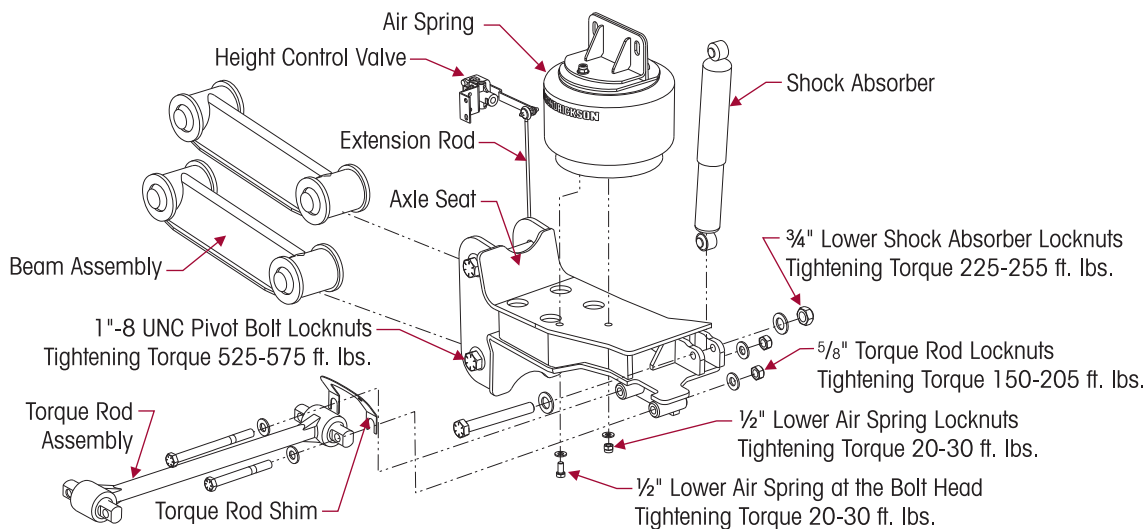

**WARNING**

PRIOR TO AND DURING DEFLATION AND INFLATION OF THE AIR SUSPENSION SYSTEM, ENSURE THAT ALL PERSONNEL AND EQUIPMENT ARE CLEAR FROM UNDER THE VEHICLE AND AROUND THE SERVICE AREA, FAILURE TO DO SO CAN CAUSE SERIOUS PERSONAL INJURY, DEATH, OR PROPERTY DAMAGE.

7. See additional Air Spring Cautions and Warnings in the Important Safety Notice Section of this publication prior to deflating or inflating the air system.
8. Inflate the suspension slowly and verify that the air spring bladder inflates uniformly without binding.
9. Reconnect the height control linkage assembly to the height control valve arm.
10. Remove the frame supports.
11. Remove the wheel chocks.
12. Verify the ride height is correct by performing a ride height inspection, refer to the Alignment & Adjustments Section of this publication.
13. Verify lateral alignment is within the vehicle manufacturers specifications.

## FRAME HANGER

### DISASSEMBLY

1. Chock the wheels.
2. Support the frame.
3. Disconnect the height control valve's leveling valve arm(s) from the rubber grommet.

**WARNING**

PRIOR TO AND DURING DEFLATION AND INFLATION OF THE AIR SUSPENSION SYSTEM, ENSURE THAT ALL PERSONNEL AND EQUIPMENT ARE CLEAR FROM UNDER THE VEHICLE AND AROUND THE SERVICE AREA, FAILURE TO DO SO CAN CAUSE SERIOUS PERSONAL INJURY, DEATH, OR PROPERTY DAMAGE.

4. See additional Air Spring Cautions and Warnings in the Important Safety Notice Section of this publication prior to deflating or inflating the air system.
5. Lower the height control valve arm(s) to exhaust the air in the air springs and deflate the suspension.

**FIGURE 9-18**

**Twin Steer Forward Front and Single Steer**

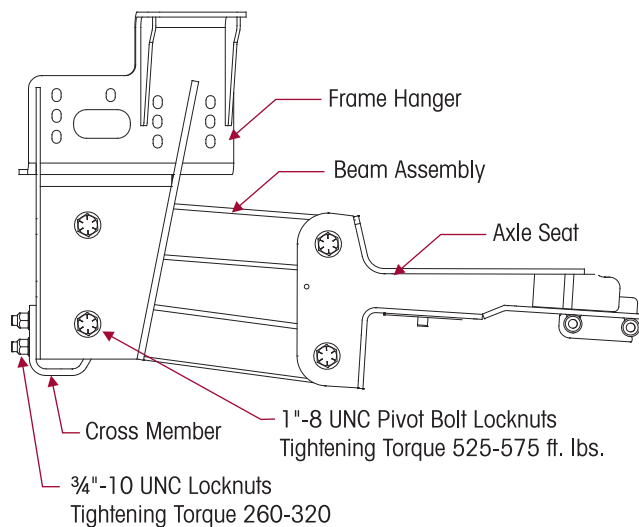

**Twin Steer Forward Rear**

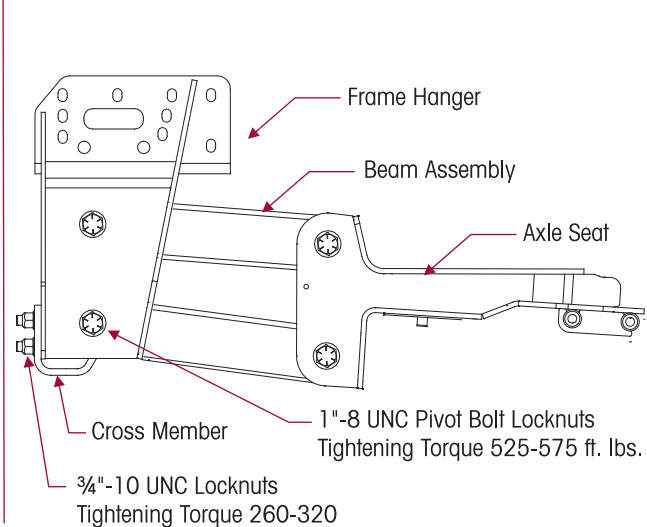

**WARNING**

SOME VEHICLE APPLICATIONS, SUCH AS VEHICLES EQUIPPED WITH OUTRIGGERS, RETAIN SOME AIR PRESSURE IN THE AIR SPRINGS AT ALL TIMES. PRIOR TO PERFORMING ANY MAINTENANCE, SERVICE, OR REPAIR OF THE SUSPENSION, VERIFY EACH AIR SPRING IS COMPLETELY DEFLATED. FAILURE TO DO SO COULD RESULT IN SERIOUS PROPERTY DAMAGE AND/OR SEVERE PERSONAL INJURY.

6. Verify that the air springs are deflated.
7. Remove beam assemblies, see Beam Assembly in this section.
8. Remove the 3/4" fasteners that attach cross member to frame hanger and remove the cross member.
9. Remove the fasteners that attach the frame hanger to the vehicle per vehicle manufacturer's specifications.
10. Remove frame hanger.

### ASSEMBLY

1. Install the new fasteners that attach the frame hanger to the vehicle. Snug but **DO NOT** tighten at this time.
2. Position the cross member against the frame hanger.
3. Install the cross member fasteners through the frame hanger, then through the cross member. Verify the fastener heads are on the inside of the frame hanger.
4. Tighten the cross member fasteners to  260-320 foot pounds.
5. Tighten frame hanger to frame fasteners per vehicle manufacturer's specifications.
6. Attach the beam assemblies, see Beam Assembly in this section.



### WARNING

PRIOR TO AND DURING DEFLATION AND INFLATION OF THE AIR SUSPENSION SYSTEM, ENSURE THAT ALL PERSONNEL AND EQUIPMENT ARE CLEAR FROM UNDER THE VEHICLE AND AROUND THE SERVICE AREA, FAILURE TO DO SO CAN CAUSE SERIOUS PERSONAL INJURY, DEATH, OR PROPERTY DAMAGE.

7. See additional Air Spring Cautions and Warnings in the Important Safety Notice Section of this publication prior to deflating or inflating the air system.
8. Inflate the suspension slowly and verify that the air spring bladder inflates uniformly without binding.
9. Reconnect the height control linkage assembly to the height control valve arm.
10. Remove the frame supports.
11. Remove the wheel chocks.
12. Verify the ride height is correct by performing a ride height inspection, refer to the Alignment & Adjustments Section of this publication.



## SECTION 10

# Troubleshooting Guide

PARASTEER HD TROUBLESHOOTING GUIDE		
CONDITION	POSSIBLE CAUSE	CORRECTION
Suspension has harsh or bumpy ride	Air spring not inflated to specification or damaged	Repair air system and check ride height. See Ride Height Adjustment in the Alignment & Adjustments Section.
	Ride height set incorrectly	Adjust ride height to proper setting. See Ride Height Adjustment in the Alignment & Adjustments Section.
	Suspension is overloaded	Redistribute load to correct weight.
Irregular tire wear	Incorrect tire inflation pressure	Correct tire pressure per vehicle manufacturer and tire manufacturer's specifications.
	Worn transverse torque rod bushings	Replace torque rod bushings as necessary.
	Incorrect alignment	Inspect suspension and steering components for worn, bent, damaged components. Replace as necessary. Verify and correct rear tandem axle alignment as necessary.
Suspension is noisy	Loose fastener(s)	Tighten fastener(s) to specifications, see Preventive Maintenance and Torque Specifications Sections.
	Worn steering components	Refer to vehicle manufacturer for proper steering component diagnosis.
	Worn bushings and/or thrust washers	Replace bushings and/or thrust washers as necessary.
Vehicle bouncing excessively	Damaged or leaking shock absorber	Replace shock absorber.
	Ride height set incorrectly	Adjust ride height to proper setting, see Ride Height Adjustment in the Alignment & Adjustments Section.
Vehicle leaning	Air Spring leaking or damaged	Replace Air Spring.
	Load not centered	Redistribute the load.
	Frame twisted	Straighten the frame per vehicle manufacturer's guidelines.
	Ride height set incorrectly	Adjust ride height to proper setting, see Ride Height Adjustment in the Alignment & Adjustments Section.
	Worn bushings and/or thrust washers	Replace bushings and/or thrust washers as necessary.
Suspension will not reach ride height	Suspension is overloaded	Redistribute load and/ or correct weight.
	Air Spring leaking or damaged	Replace Air Spring.
	Leak in air system	Check with soapy water, also refer to the Air Fitting Inspection in the Preventive Maintenance Section. Repair air system and check ride height. See Ride Height Adjustment in the Alignment & Adjustments Section.
	Air line obstructed or improperly connected	Repair air system and check ride height. See Ride Height Inspection in the Alignment & Adjustments Section.
Air springs deflate when parked	Leak in air system	Check with soapy water, also refer to the Air Fitting Inspection in the Preventive Maintenance Section. Repair air system and check ride height. See Ride Height Adjustment in the Alignment & Adjustments Section.
	Inproper function in the height control valve	See height control valve test procedure in the Preventive Maintenance Section of this publication. Replace height control valve if necessary.

# SECTION 11 Plumbing Diagram

## SINGLE STEER

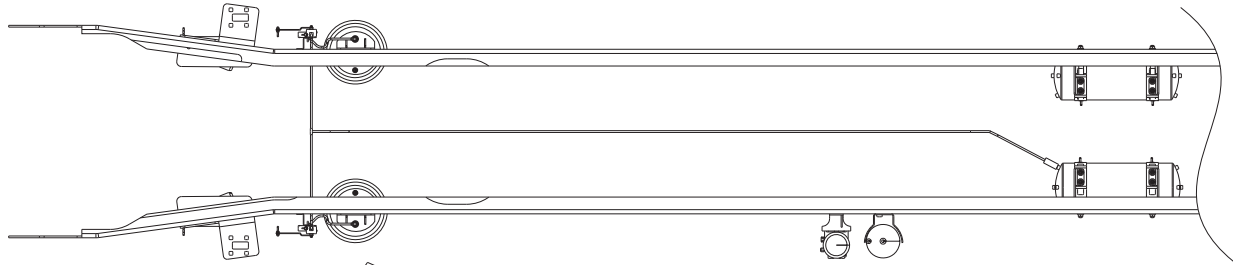

**NOTE:**  
For Pressure Protection Valve,  
if equipped, refer to the vehicle manufacturer.

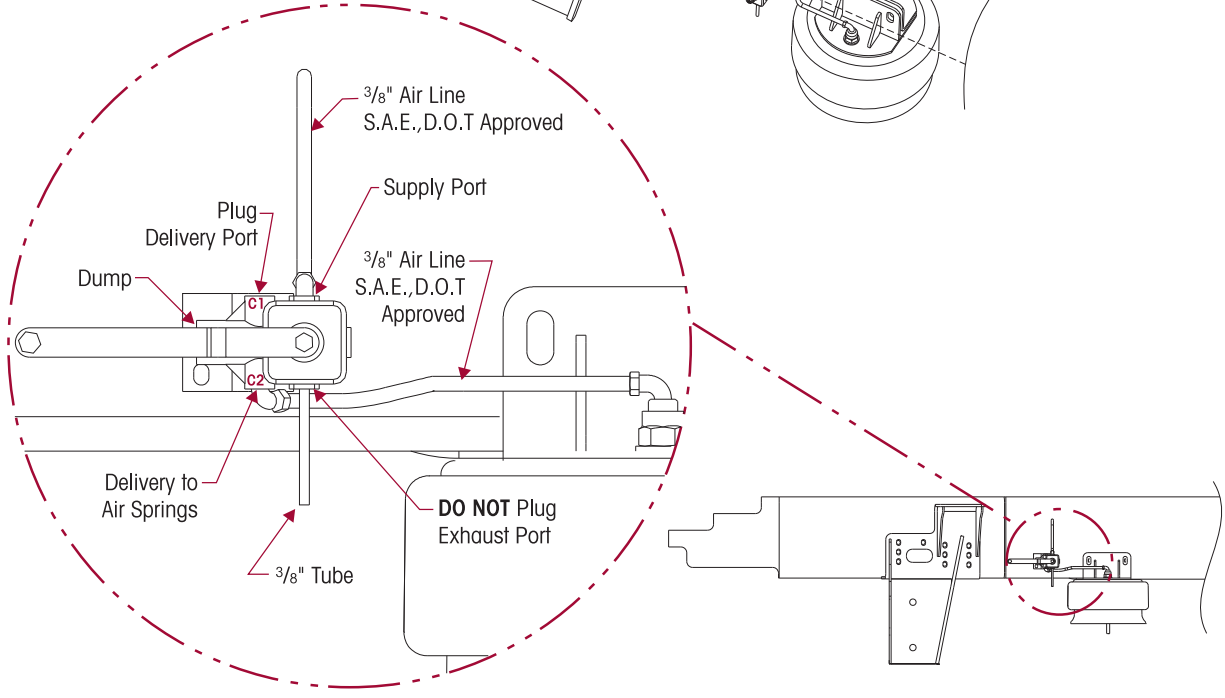
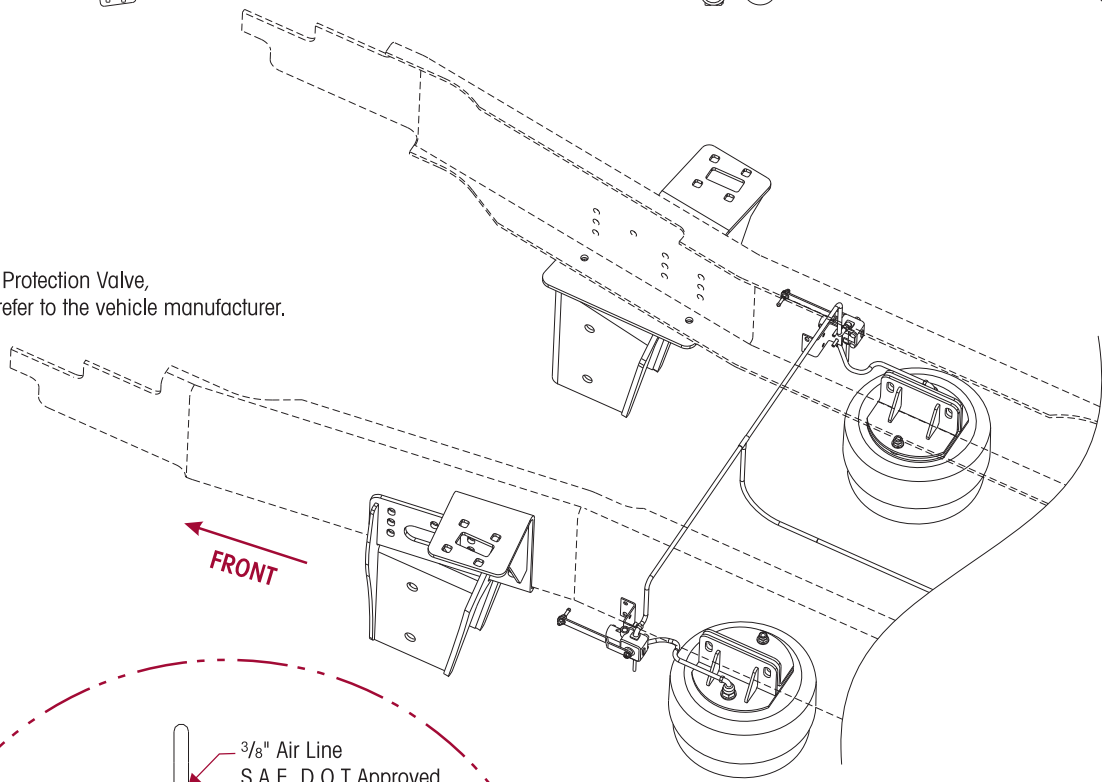



TWIN STEER

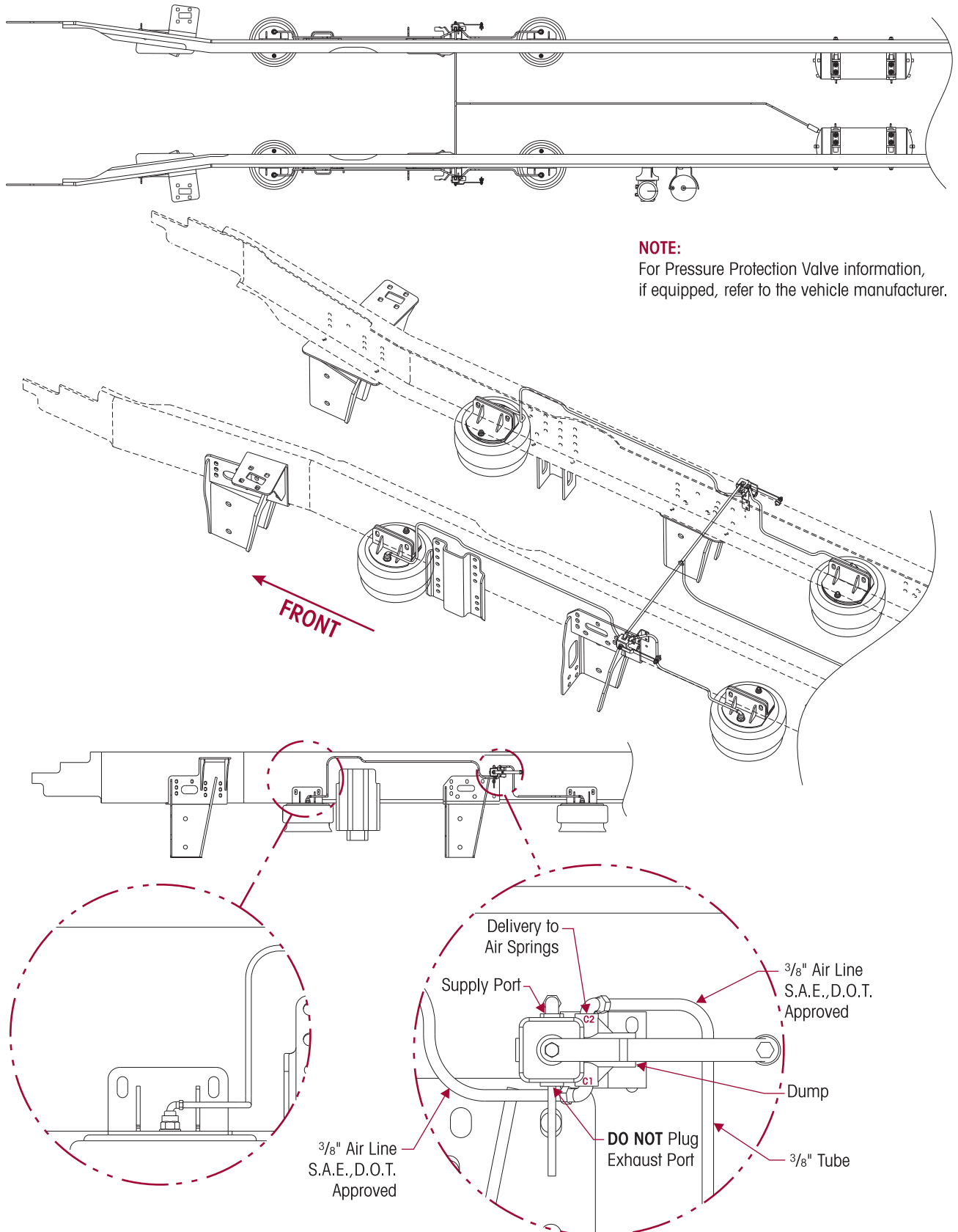

# SECTION 12 Torque Specifications

## Twin Steer Forward Front and Single Steer

Recommended torque values  
provided in foot pounds

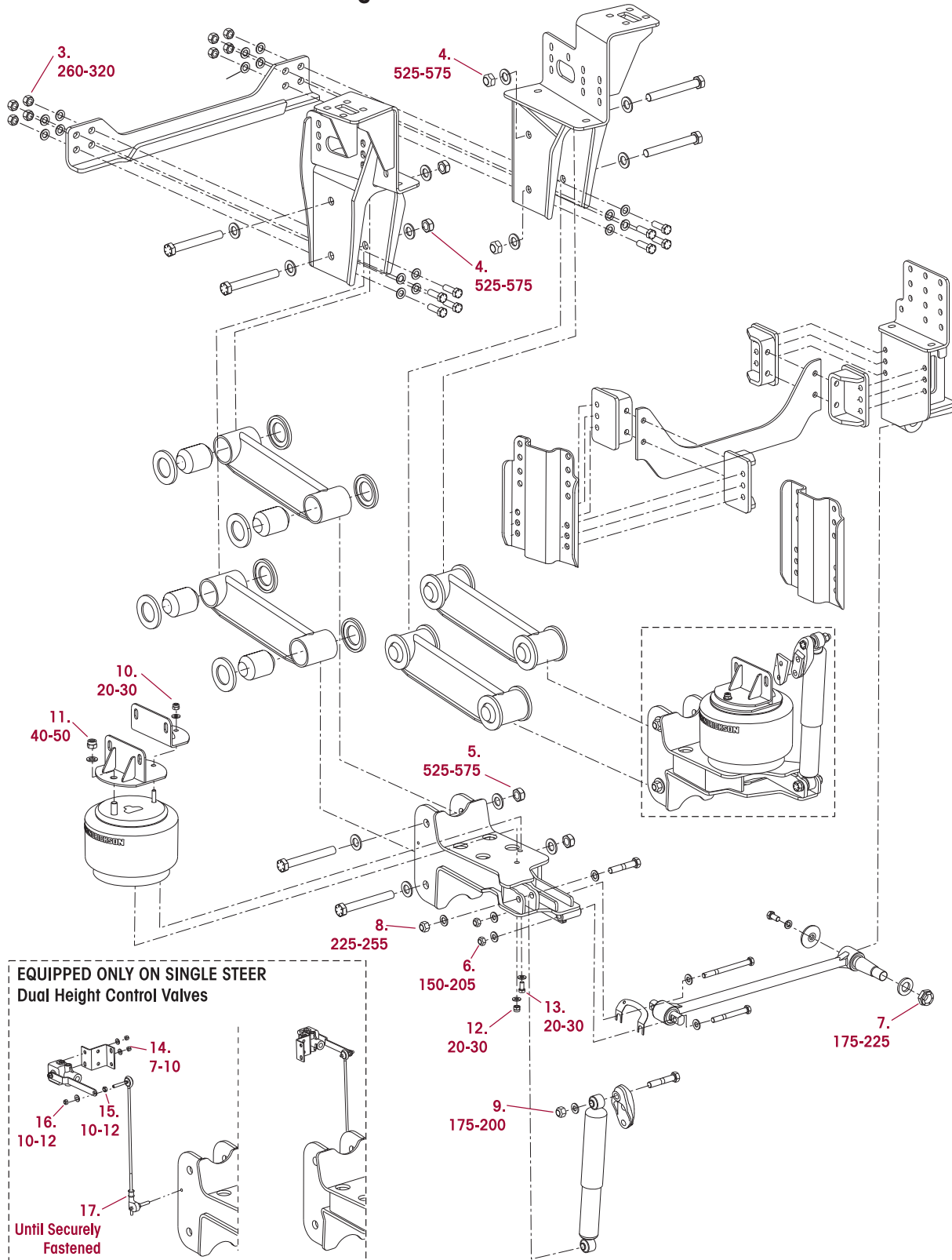





## PARASTEER HD™ TWIN STEER FORWARD FRONT AND SINGLE STEER

### HENDRICKSON RECOMMENDED TORQUE SPECIFICATIONS

NO.	DESCRIPTION	QUANTITY	SIZE	*TORQUE VALUE (in foot pounds)
1.	Frame Hanger to Frame	**Furnished and installed by vehicle manufacturer		
2.	Air Spring Mounting Bracket to Frame	**Furnished and installed by vehicle manufacturer		
3.	Cross Member to Frame Hanger	8	¾"-10 UNC	260-320
4.	Frame Hanger to Beam Assembly	4	1"-8 UNC	525-575
5.	Beam Assembly to Axle Seat	4	1"-8 UNC	525-575
6.	Axle Seat to Torque Rod Assembly	4	⅝"-11 UNC	150-205
7.	Torque Rod Assembly to Torque Rod Bracket	1	1¼"-12 UNF	175-225
8.	Shock Absorber to Axle Seat	2	¾"-10 UNC	225-255
9.	Shock Absorber to Upper Shock Bracket Assembly	2	¾"-10 UNC	175-200
10.	Air Spring to Inner Mounting Bracket	2	½"-13 UNC	20-30
11.	Air Spring to Outer Mounting Bracket	2	¾"-16 UNF	40-50
12.	Air Spring to Axle Seat	2	½"-13 UNC	20-30
13.	Axle Seat to Air Spring at the Bolt Head	2	½"-13 UNC	20-30
14.	Height Control Valve to HCV Frame Bracket	4	¼"-20 UNC	7-10
15.	HCV Linkage Jam Nut	2	⅝"-18 UNC	10-12
16.	HCV Linkage to HCV	2	⅝"-18 UNC	10-12
17.	HCV Linkage Clamp	1		Securely Fastened

**NOTE:** \* Torque values listed apply only if Hendrickson supplied fasteners are used. If non Hendrickson fasteners are used, follow torque specification listed in vehicle manufacturer's service manual.

\*\* All hardware grayed out in the matrix denotes items not shown on illustration. For torque requirements see the vehicle manufacturer.

Twin Steer Forward Rear

Recommended torque values provided in foot pounds

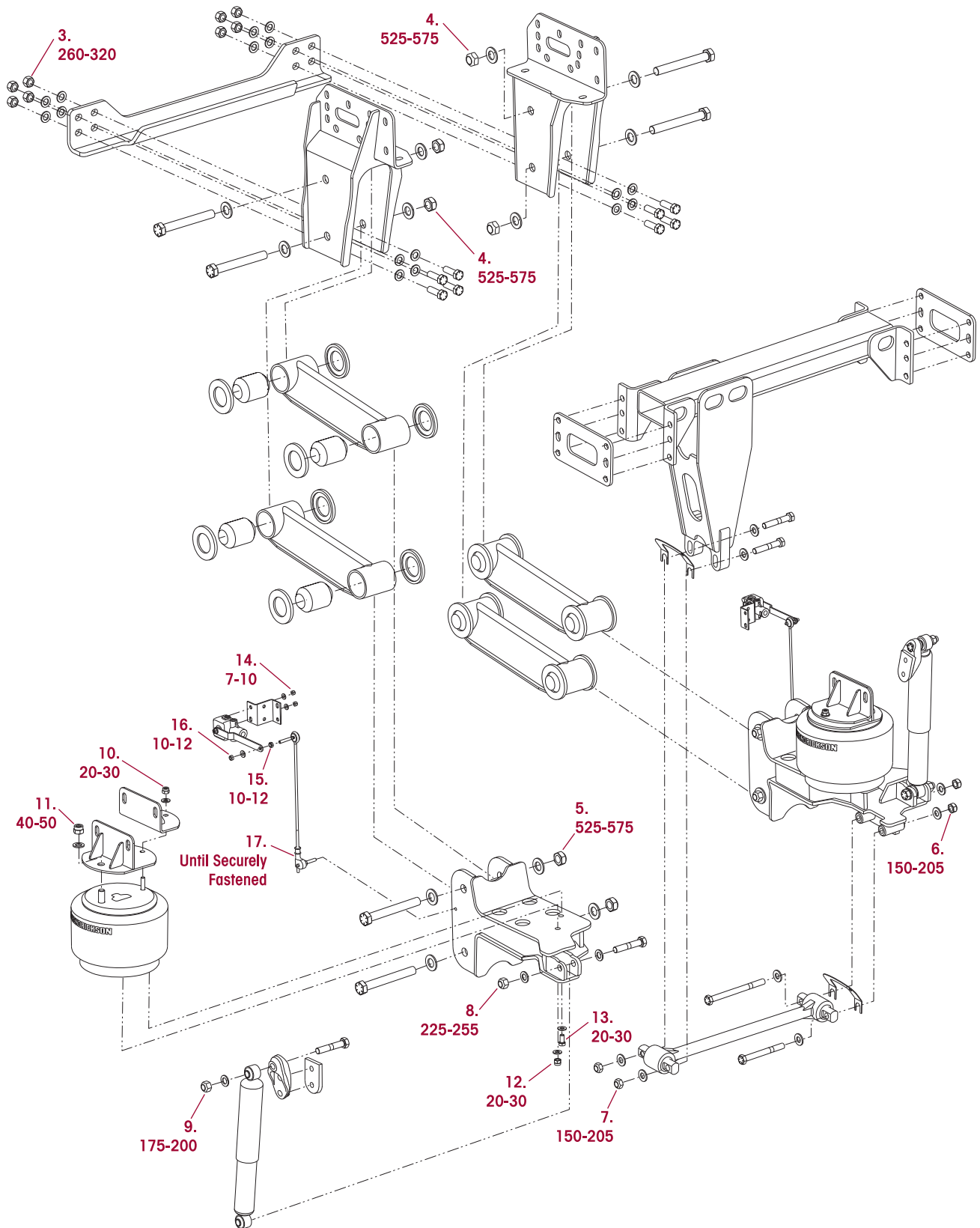



## PARASTEER HD™ TWIN STEER FORWARD REAR

## HENDRICKSON RECOMMENDED TORQUE SPECIFICATIONS

NO.	DESCRIPTION	QUANTITY	SIZE	*TORQUE VALUE (in foot pounds)
1.	Frame Hanger to Frame	**Furnished and installed by vehicle manufacturer		
2.	Air Spring Mounting Bracket to Frame	**Furnished and installed by vehicle manufacturer		
3.	Cross Member to Frame Hanger	8	¾"-10 UNC	260-320
4.	Frame Hanger to Beam Assembly	4	1"-8 UNC	525-575
5.	Beam Assembly to Axle Seat	4	1"-8 UNC	525-575
6.	Axle Seat to Torque Rod Assembly	4	⅝"-11 UNC	150-205
7.	Torque Rod Assembly to Cross Tube Assembly	1	⅝"-11 UNC	150-205
8.	Shock Absorber to Axle Seat	2	¾"-10 UNC	225-255
9.	Shock Absorber to Upper Shock Bracket Assembly	2	¾"-10 UNC	175-200
10.	Air Spring to Inner Mounting Bracket	2	½"-13 UNC	20-30
11.	Air Spring to Outer Mounting Bracket	2	¾"-16 UNF	40-50
12.	Air Spring to Axle Seat	2	½"-13 UNC	20-30
13.	Axle Seat to Air Spring at the Bolt Head	2	½"-13 UNC	20-30
14.	Height Control Valve to HCV Frame Bracket	4	¼"-20 UNC	7-10
15.	HCV Linkage Jam Nut	2	⅝"-18 UNC	10-12
16.	HCV Linkage to HCV	2	⅝"-18 UNC	10-12
17.	HCV Linkage Clamp	1		Securely Fastened

**NOTE:** \* Torque values listed apply only if Hendrickson supplied fasteners are used. If non Hendrickson fasteners are used, follow torque specification listed in vehicle manufacturer's service manual.

\*\* All hardware grayed out in the matrix denotes items not shown on illustration. For torque requirements see the vehicle manufacturer.

---

[www.hendrickson-intl.com](http://www.hendrickson-intl.com)



Truck Suspension Systems  
800 South Frontage Road  
Woodridge, IL 60517-4904 USA

630.910.2800  
Fax 630.910.2899