

# **H** TECHNICAL BULLETIN

## HAULMAAX® Rebound Strap Enhancement Kits for Outrigger Applications

**SUBJECT:** Kit Nos. 64179-045 and 64179-046

**LIT NO:** SEU-0232

**DATE:** October 2010

**REVISION:** A

### IMPORTANT NOTICE

Hendrickson has recently made available two new enhanced rebound strap kits for vehicles equipped with HAULMAAX®, to be used on as needed basis in applications that utilize outriggers in severe environments with uneven terrain. Typical applications benefiting from this kit may include but are not limited to; concrete pumpers, digger derricks, and well diggers.

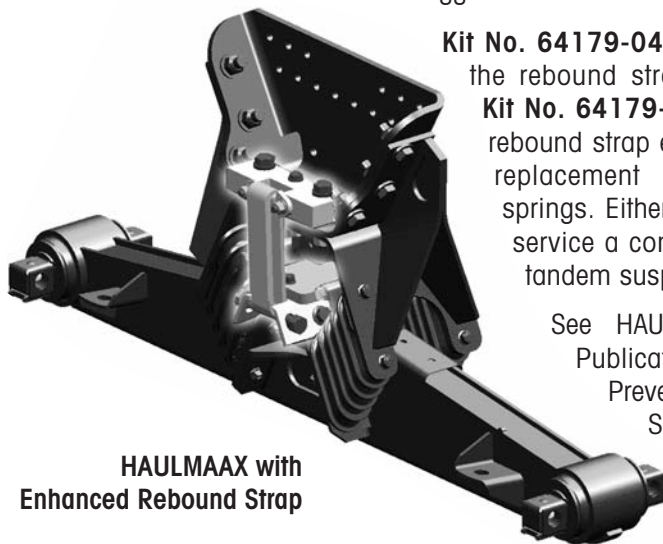

**HAULMAAX with Enhanced Rebound Strap**

**Kit No. 64179-045** contains only the rebound strap enhancement.

**Kit No. 64179-046** contains the rebound strap enhancement plus replacement \*tie-bar bolsters springs. Either kit is intended to service a complete HAULMAAX tandem suspension.

See HAULMAAX Technical Publication 17730-244 Preventive Maintenance Section for bolster springs replacement criteria.

### THE NEW ENHANCED DESIGN

- Enhanced rebound straps further protect the bolsters from overextension during outrigger use in severe environments with uneven terrain
- Easy installation upgrade from current production rebound strap

\* Since June 2006, new HAULMAAX 460 suspension systems have been equipped with tie-bar bolsters springs. Replacement tie-bar bolsters springs may be used in HAULMAAX 400 and 460 applications. However, replacement non-tie-bar bolsters are also available separately for your HAULMAAX 400. See Hendrickson Literature No. SEU-0225 or contact Hendrickson for further details.

#### Outrigger Applications – Rebound Strap Enhancement Kit No. 64179-045

**NOTE:** Kit contents will service complete tandem suspension

DESCRIPTION	Qty.
¾"-16 UNF 6.0" Bolt	4
¾"-16 UNF Locknut	4
¾" Hardened Washer	4
¾"-10 UNC 4.0" Bolt	4
¾"-10 UNC Flange Locknut	4
½"-13 UNC 1.5" Bolt	4
½"-13 UNC 4.0" Bolt	12
½"-13 UNC 5.0" Bolt	2
½"-13 UNC Flange Nut	18
½" Hardened Washer	14
⅝"-11 UNC 1.5" Flange Bolt	8
⅝"-11 UNC Flange Nut	8
Rebound Strap	4
Auxiliary Spring Contact Plate	2
Rebound Clip	2
Auxiliary Spring Spacer	2
Inboard Rebound Support Block	2
Outboard Rebound Support Block	2

#### Outrigger Applications – Rebound Strap Enhancement and Tie-bar Kit No. 64179-046

**NOTE:** Kit contents will service complete tandem suspension

DESCRIPTION	Qty.
Rebound Strap Enhancement Kit No. 64179-045	1
Tie-bar Bolster Spring Kit No. 64179-037	4

## INSTALLATION

**Kit No. 64179-045** contains Hendrickson Assembly Instructions (Lit No. 59310-048) for installation of the rebound strap enhancement kit. **Kit No. 64179-046** contains installation instructions for both the rebound strap enhancement kit (Lit No. 59310-048) and the tie-bar bolsters (Lit No. 59310-029).

See Hendrickson Technical Publication 17730-244 for complete maintenance, service and safety instructions regarding the HAULMAAX suspension, available online at [www.hendrickson-intl.com](http://www.hendrickson-intl.com).

### NOTE

Installation of the rebound strap enhancement will involve replacement of the standard inboard mounted rebound strap and standard auxiliary spring contact plate with a special auxiliary spring contact plate, inboard and outboard rebound support blocks and enhanced rebound straps on both sides of the suspension, see Figures 1 and 2.

FIGURE 1

### INBOARD SIDE

#### STANDARD REBOUND STRAP

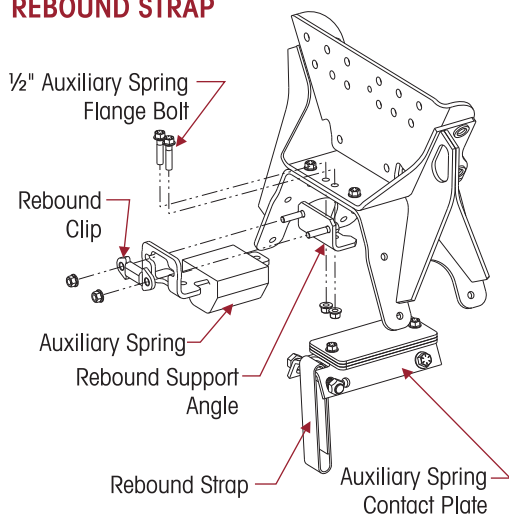

#### REBOUND STRAP ENHANCEMENT

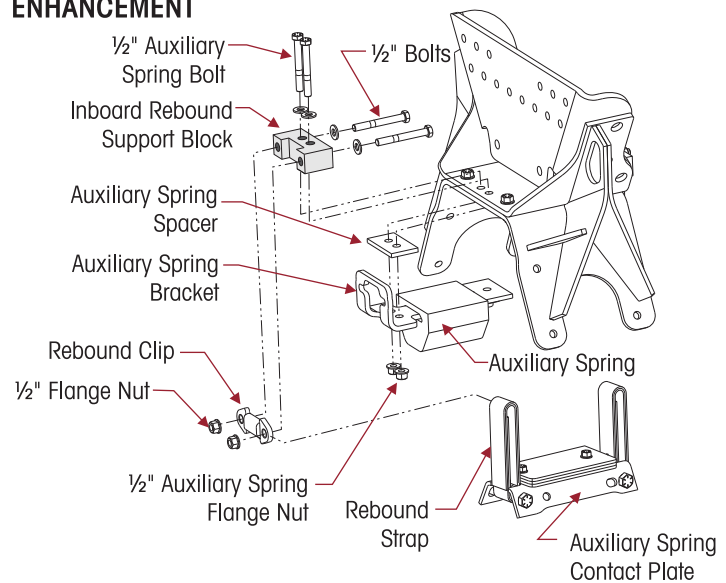
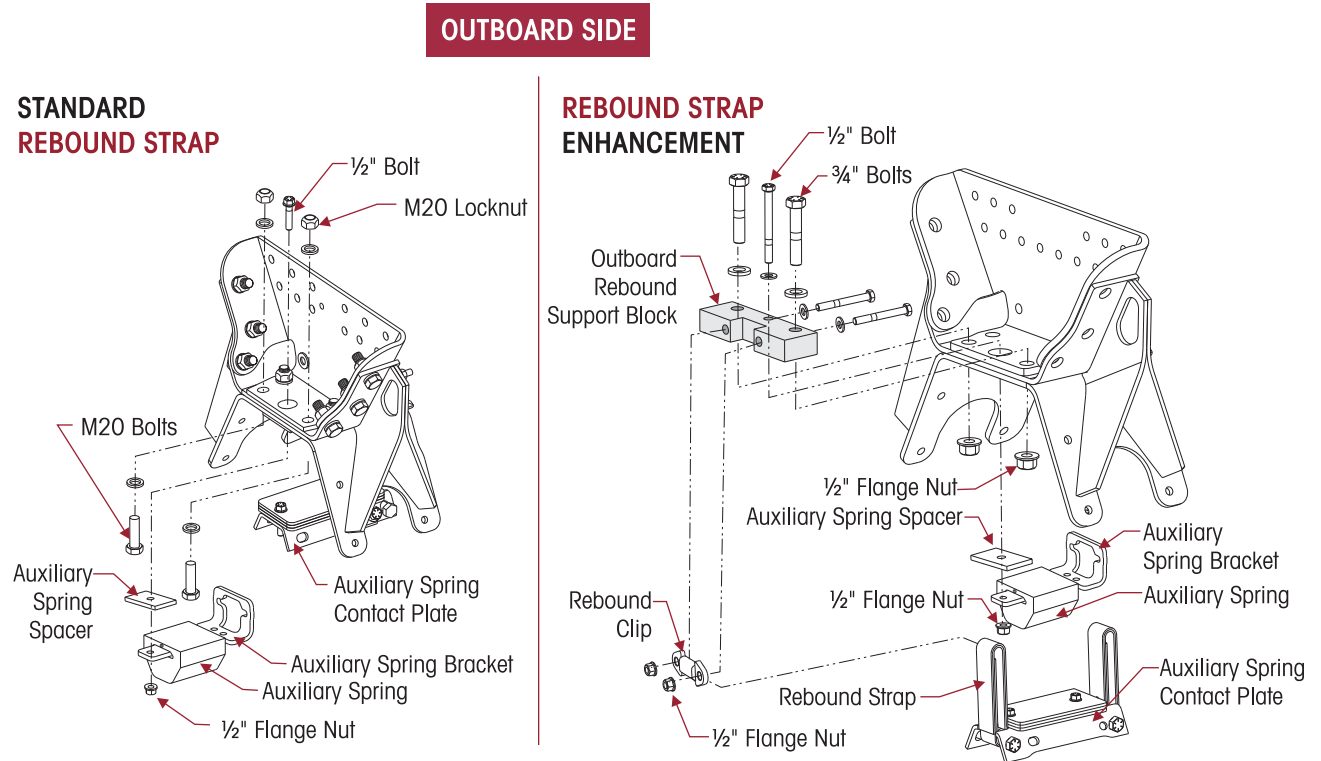



FIGURE 2



Refer any questions regarding this publication to Hendrickson Tech Services toll-free at 866-755-5968, or email: [techservices@hendrickson-intl.com](mailto:techservices@hendrickson-intl.com). For more information on Hendrickson products go to [www.hendrickson-intl.com](http://www.hendrickson-intl.com).

---

[www.hendrickson-intl.com](http://www.hendrickson-intl.com)



Truck Suspension Systems  
800 South Frontage Road  
Woodridge, IL 60517-4904 USA

630.910.2800  
Fax 630.910.2899