

**⚠ CAUTION: DO NOT ADJUST THE MINIMUM AIR SPRING  
AIR PRESSURE HIGHER THAN 10 PSI!**

PRESSURE REGULATOR

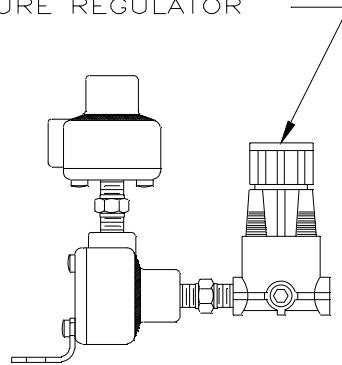

The air suspension system for this vehicle has an adjustable pressure retaining kit. The kit maintains minimum air pressure in the air springs when they are exhausted.

Minimum air spring pressures higher than 10 psi may cause the following problems:

- override the vehicle's height control valve or suspension regulator
- raise the vehicle
- result in possible suspension damage

COPYRIGHT © 1995 THE BOLER COMPANY.  
ALL RIGHTS RESERVED  
L470 DECEMBER 1995

**H HENDRICKSON**<sup>®</sup>