

# **H** TECHNICAL BULLETIN

## AIRTEK RIDE HEIGHT ADJUSTMENT PROCEDURE

SUBJECT: AIRTEK™ for Freightliner Vehicles

LIT NO: SEU-0211

DATE: January 2002 REVISION: A

### IMPORTANT NOTICE

#### AIRTEK™ REVISED RIDE HEIGHT ADJUSTMENT PROCEDURE

Hendrickson has learned of a potential service issue regarding the height control valve on vehicles equipped with the AIRTEK suspension. After performing a ride height adjustment procedure, the bottom socket head cap screws may loosen up if the 1/4" height control valve mounting locknuts are not properly re-tightened. Loose cap screws may cause an air leak between the two halves of the height control valve body. Such an air leak may affect suspension performance and proper operation of air system components in the suspension.

Hendrickson recommends the following be performed during any type of ride height adjustment to help prevent socket head cap screws from loosening from the height control valve housing, and any subsequent air leaks from the height control valve.

1. Prior to adjusting the height control valve, clean the threads of the 1/4" fasteners of any debris and corrosion.
2. After the adjustment is made, install a 3/16" allen wrench in the bottom socket head cap screws to prevent the screws from turning while re-tightening the 1/4" locknuts. See Figure 1.
3. Re-tighten the locknuts to 7-10 foot pounds torque. See Figure 2.

The above procedure should also be performed in the event an air leak is detected in the height control valve. If air continues to leak after the socket head cap screws have been properly re-tightened, the height control valve should be replaced.

For further information regarding this matter, please contact Hendrickson's Field Service Department at 630.910.2800. Also, please reference Hendrickson Technical Publication Number 17730-243 for additional detailed service instructions for the AIRTEK suspension.

Figure 1

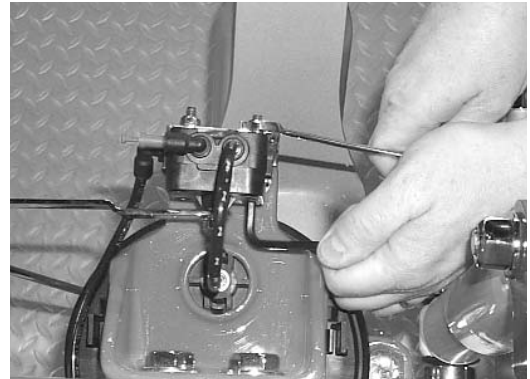
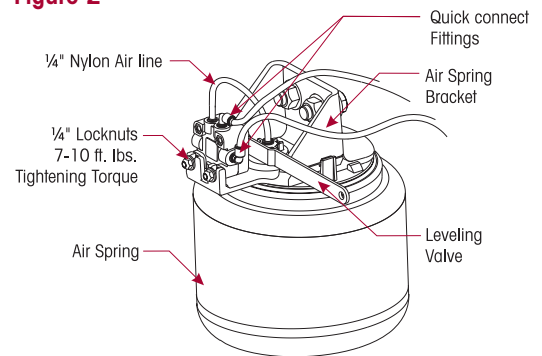

Figure 2





Information contained in this literature was accurate at the time of publication. Product changes may have been made after the copyright date that are not reflected.

SEU-0211A 1M 1-Q2 Printed in United States of America.

Truck Suspension Systems  
800 S. Frontage Road  
Woodridge, IL 60517-4904

630.910.2800  
FAX 630.910.2899  
[www.hendrickson-intl.com](http://www.hendrickson-intl.com)

The Boler Company  
Copyright © 2002  
All Rights Reserved