

- Stronger
- Lighter
- Less maintenance

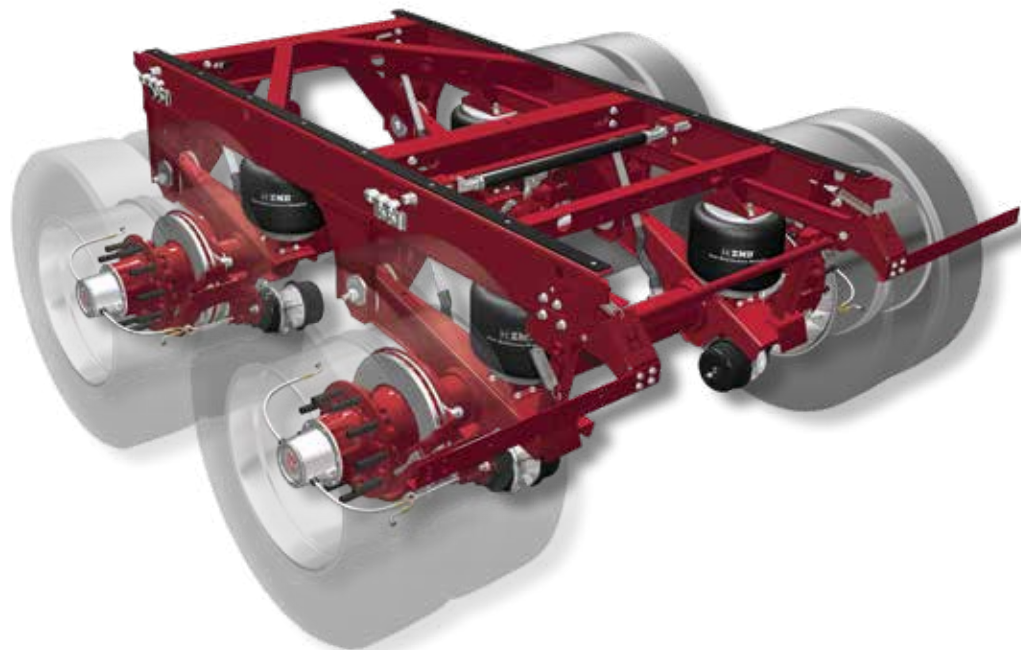

#### **Engineered for Toughness**

Hendrickson introduces the latest in air slider technology with the ULTRAA-K® axle suspension system – the next generation VANTRAAX® air slider system for the van and refrigerated trailer markets.

Hendrickson engineered the ULTRAA-K slider box for toughness with several advancements including:

- Reinforced slider main rail
- Overlapping frame brackets
- Optimized cross members, gussets and diagonal “K” braces

#### **Lightweight Design**

Building on proven VANTRAAX air slider design expertise, the ULTRAA-K system is engineered with an optimized strength-to-weight ratio making it stronger than comparable standard and heavy duty 40K slider models in the market today.

Hendrickson’s ULTRAA-K system is lighter than typical tandem air slider systems by nearly 100 pounds.

#### **Elite System Featuring Exclusive Technology**

The ULTRAA-K system is standard with industry exclusive and patented<sup>▲</sup> features that further elevate its elite status including:

- ZMD® ZERO MAINTENANCE DAMPING® ride technology
- Pivoting mud flap brackets
- Protected height control valve mounting

Hendrickson backs the ULTRAA-K system with a limited ten-year structural corrosion warranty.\*

\* Contact your local Hendrickson representative for complete warranty terms, conditions and limitations.

▲ This product is covered by at least one or more U.S. and/or foreign patents and/or pending U.S. and/or foreign patent applications. See Hendrickson for details.



To learn more about the ULTRAA-K system, call 866.743.3247 or visit [www.hendrickson-intl.com](http://www.hendrickson-intl.com)

# ULTRAA-K® Features and Benefits

## Improved Air Spring Supports

- Increases strength and durability
- Easier access to air spring mounting studs

## Diagonal "K" Bracing

- Prevents racking
- Increases strength and slider life

## Overlapping Frame Brackets

- Stronger attachment
- Improves durability and hanger life

## Optimized Slider Rail

- Optimized structural geometry
- Stronger than VANTRAAAX® 40K HD model
- Reduces weight

## Height Control Valve Mounting

- Ensures more accurate ride height settings
- More secure location protects against road debris

## Hat-Section Cross Members and Gussets

- More rigid design
- Longer slider life

## Exclusive ZMD® Shockless Ride Technology

- Uniform damping levels over life of the trailer
- Reduces overall suspension maintenance
- Superior ride quality and driver comfort
- Enhances cargo protection
- Reduces risk of roadside tickets and CSA violations

## Pivoting Mud Flap Brackets

- Helps prevent mud flap damage
- Reduces component maintenance

## New SURELOK® System Design

- Eliminates stop bolt
- Less component wear

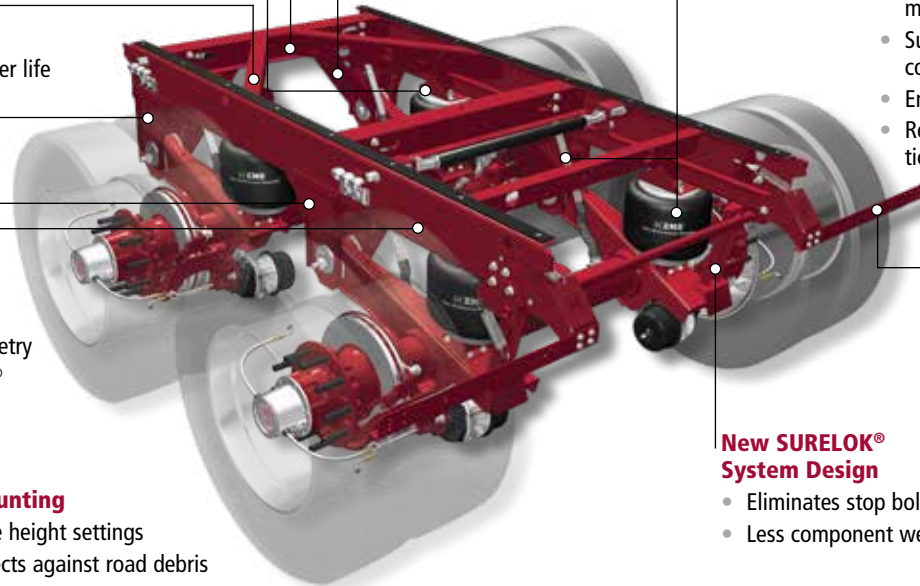

## Value-Added Options

- RTR® READY-TO-ROLL® wheel-end options reduce weight, enhance durability and lower maintenance
  - **HXL3® Hendrickson Extended-Life 3-year System™** features a three-year limited on-highway warranty\*
  - **HXL5® Hendrickson Extended-Life 5-year System™** features a five-year limited on-highway warranty\*
  - **HXL7® Hendrickson Extended-Life 7-year System™** features a seven-year limited on-highway warranty\*
- TIREMAAX® PRO tire inflation system helps maximize tire life and maintain peak fuel mileage
- Hendrickson MAXX22T™ optimized trailer air disc brakes available
  - See *TIREMAAX PRO Brochure - Literature No. L1199*
  - See *MAXX22T Flyer - Literature No. L1239*

See *RTR READY-TO-ROLL Wheel-End flyer - L1200*

\*Contact your local Hendrickson representative for complete warranty terms, conditions and limitations.

## Specifications

MODEL	AXLE ARRANGEMENT	AXLE SPACING (Inches)	SYSTEM CAPACITY (lbs.)	AXLE RATING (lbs.)	AXLE DIAMETER (Inches)	BOX WIDTH (Inches)	RISE HEIGHTS (Inches)	BASE MODEL WEIGHT* (lbs.)
UTKNT 40K	Tandem	49	40,000	20,000	LDA™	48	16	1,322**
HKANT 40K with Options								1,426**

\* Weight includes slider, suspension, HN spindle and foundation brakes for 48-inch wide slider box.

\*\* Includes the following options: mud flap mounting, height control valve components and the air reservoir mounting brackets.

Actual product performance may vary depending upon vehicle configuration, operation, service and other factors.

All applications must comply with applicable Hendrickson specifications and must be approved by the respective vehicle manufacturer with the vehicle in its original, as-built configuration. Contact Hendrickson for additional details regarding specifications, applications, capacities, and operation, service and maintenance instructions.

Call Hendrickson at **330.489.0045** or **866.RIDEAIR (743.3247)** for additional information.



www.hendrickson-intl.com

### TRAILER COMMERCIAL VEHICLE SYSTEMS

2070 Industrial Place SE  
Canton, OH 44707-2641 USA  
866.RIDEAIR (743.3247)  
330.489.0045 • Fax 800.696.4416

### Hendrickson Canada

250 Chrysler Drive, Unit #3  
Brampton, ON Canada L6S 6B6  
800.668.5360  
905.789.1030 • Fax 905.789.1033

### Hendrickson Mexicana

Circuito El Marqués Sur #29  
Parque Industrial El Marqués  
Pob. El Colorado, Municipio El Marqués,  
Querétaro, México C.P. 76246  
+52 (442) 296.3600 • Fax +52 (442) 296.3601

L1222 Rev E 01-20

© 2014 - 2020 Hendrickson USA, L.L.C. All Rights Reserved. All trademarks shown are owned by Hendrickson USA, L.L.C., or one of its affiliates, in one or more countries, except for MAXX22T, which is owned by WABCO. Information contained in this literature was accurate at the time of publication. Product changes may have been made after the copyright date that are not reflected.

Printed in United States of America