

# TECHNICAL PROCEDURE

## TRAILER SUSPENSION SYSTEMS HENDRICKSON WHEEL-ENDS

**SUBJECT:** Recommended Stud  
Replacement Procedures

**LIT NO:** T82006  
**DATE:** January 2020

**REVISION:** B

### TABLE OF CONTENTS

<b>Introduction</b>	<b>1</b>
Safety and Precautionary Statements	1
Relative Literature	1
<b>Wheel Stud Removal / Installation Procedure</b>	<b>2</b>
Preparation	2
Stud Removal	3
Stud Installation	3
Stud Mounted U-Shaped Rotor to Hub Assembly	4
Hub And Rotor Disassembly	4
Assembling Hub and Rotor	5
<b>Wheel to Hub Assembly</b>	<b>7</b>
Hub Piloting	7
Wheel Assembly	7
Wheel Assembly Procedures	7

### INTRODUCTION

This document includes Hendrickson recommended procedures for removing and installing studs on Hendrickson RTR® READY-TO-ROLL® wheel-end packages. The procedures are the same for both drum and air disc brake (ADB) applications, including the Hendrickson stud mounted rotor.

When a stud is damaged, broken or otherwise no longer contributing to the clamping of the wheel to the hub, the two adjacent studs assume additional stress to compensate. As a result, the clamping ability of adjacent studs may also be compromised. For this reason, Hendrickson recommends replacing the damaged or missing stud(s) and each adjacent stud.

**NOTE:** Hendrickson does not stock, distribute or offer studs for vendor supplied hubs included within various Hendrickson wheel-end assemblies, except for Hendrickson's stud mounted rotor applications.

### SAFETY AND PRECAUTIONARY STATEMENTS

**⚠ WARNING** Always wear proper eye protection and other required personal protective equipment (PPE) when performing vehicle maintenance, service or repairs. Follow federal, state, local and shop safety regulations as appropriate.

**⚠ WARNING** Chock or block the wheels on the trailer to prevent movement while working on the suspension components and systems. Failure to block the trailer may lead to serious injury or death.

**⚠ CAUTION** Failure to follow these instructions could result in damage to the suspension, its components and/or individuals.

**⚠ CAUTION** Major wheel-end components are heavy and difficult to lift by hand. Use appropriate hoist and support slings to lift into position.

For more safety and precautionary statements, refer to Hendrickson literature number [T12007](#), available at [www.Hendrickson-intl.com/TrailerLit](http://www.Hendrickson-intl.com/TrailerLit).

### RELATIVE LITERATURE

If you suspect your version of this or any other Hendrickson manual is not "Up-to-Date", the most current version is available for free at:

[www.Hendrickson-intl.com/TrailerLit](http://www.Hendrickson-intl.com/TrailerLit)

Available Hendrickson documentation can be viewed or downloaded from this site.

All Hendrickson online documentation are PDF files that require Adobe Acrobat Reader or equivalent to open and view. This free downloadable application from Adobe's home page (<http://get.adobe.com/reader/>).



Other relative literature may include:

LIT NO.	DESCRIPTION
L583	Comprehensive Warranty Statement
L974	Drum Brake Maintenance Procedures
T12007	General Safety Precautions and Information for Technical Procedures
T71004	Hub and Rotor Assembly, and Caliper Mounting Procedures
T72002	HXL7® Wheel-end Maintenance Procedures
T72004	HLS® Wheel-end Maintenance Procedures
T72005	HVS® Wheel-end Maintenance Procedures
T72006	HXL3® Wheel-end Maintenance Procedures
T72007	HXL5® Wheel-end Maintenance Procedures
ConMet PreSet®	Refer to Vendor Links available at <a href="http://www.hendrickson-intl.com/TrailerLit">www.hendrickson-intl.com/TrailerLit</a>

Table 1: Relative wheel-end literature

## WHEEL STUD REMOVAL / INSTALLATION PROCEDURE

For a list of literature relative to wheel-end maintenance, refer to RELATIVE LITERATURE and Table 1.

**NOTE:** This procedure also applies to changing damaged studs on wheel-ends with the Hendrickson stud mounted rotor ADB system. Refer to Hendrickson STUD MOUNTED U-SHAPED ROTOR TO HUB ASSEMBLY on page 4 for instructions on disassembly and assembly.

**IMPORTANT:** To maintain wheel-end integrity, Hendrickson recommends replacing the damaged stud(s) and the adjacent stud on each side.

### PREPARATION

1. Follow shop recommended procedures to **secure the trailer** before continuing to next step.
2. **Raise axle** of the wheel requiring service off the ground.
3. **Remove tire** and wheel assembly.

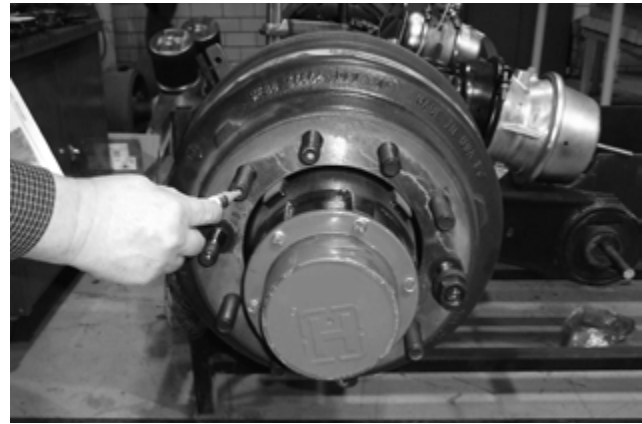

Figure 1: Identifying "old" studs

4. Using a paint stick or some other suitable marker, **mark studs to be replaced** so they do not get mixed up with new replacement studs (Figure 1).

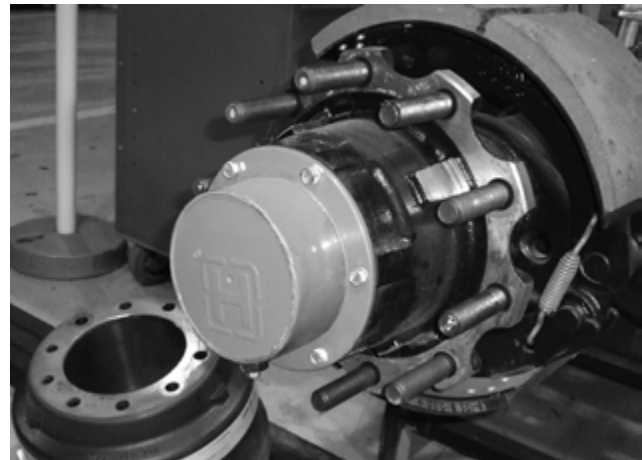

Figure 2: Brake drum removed

5. Remove brake components:
  - A. **If drum brake, remove brake drum** (Figure 2).



Figure 3: Retracting brake shoes



**NOTE:** In some instances, it may be necessary to slightly retract the brake shoes so the drum can clear the brake shoe / lining assembly (Figure 3).

For detailed slack adjuster instructions, refer to "RETRACTING BRAKE SHOES OR SLACK ADJUSTER CONTROL ARM(S)" in Hendrickson literature number L974 *Drum Brake Maintenance Procedures*.

- B. **If disc brakes with long studs and U-shaped rotor:** the rotor may interfere with stud removal and insertion. **It may be necessary to remove the caliper and separate the rotor from the hub.** Refer to Hendrickson literature number T71004 *ADB Hub / Rotor Assembly and Caliper Mounting Procedures*.

## STUD REMOVAL

This procedure shows removal of one stud. If more studs are to be removed, repeat as needed.

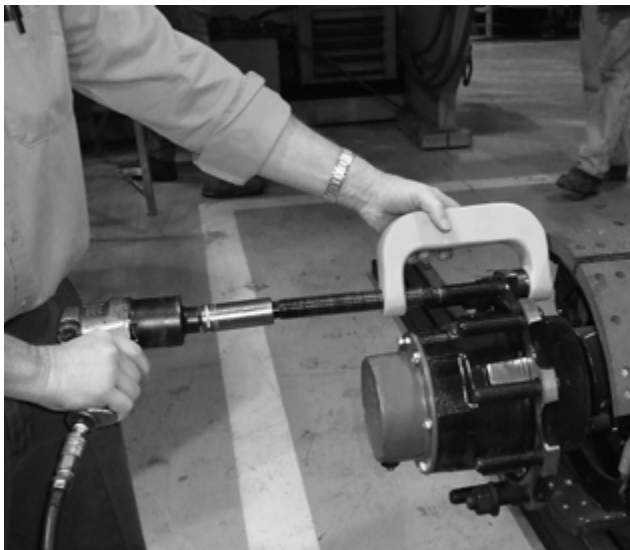

Figure 4: Extracting studs

**NOTICE** DO NOT use hammers, sledge or other tools to pound out studs. This can damage the hub or cause impact damage to the bearing raceway, reducing bearing life.

1. Use a stud remover (Figure 4) to **extract** all marked stud(s).
2. **Discard** all removed studs.
3. **Record** serial number of hub for future reference and service records.

## STUD INSTALLATION

This procedure shows installation of one stud. If more studs are to be installed, repeat as needed.

1. **Clean** all related flat surfaces on hub with buffer or crocus cloth.



Figure 5: Installing new studs

2. **Install** new stud into hub (Figure 5). If possible, line up knurls on the replacement stud with impressions (grooves) in the hub stud hole made by the removed stud.
3. **Obtain** a good condition matching nut and hardened washer(s) for the stud.

**NOTE:** Some studs have threads that do not go the full length of the stud. For these studs, the nut will not contact with hub outer surface and provide the clamp load necessary to pull-in the stud. Either install stud with drum in place or use hardened washers as temporary spacers.

A two-piece flange wheel nut or standard nut and hardened washer can be used for this purpose. The nut must be discarded at the end of this procedure. If using a two-piece flange wheel nut, the hardened washer is not required; however, the flange must rotate freely.

**IMPORTANT:** **DO NOT** lubricate threads. Doing so will reduce the friction between fastener components which can lead to overtightening, unpredictable clamp loads and an unreliable fastener connection.

4. **Place** washer(s) and nut on the newly installed stud.



- Use a ½ inch drive impact wrench to **tighten** nut and **draw replacement studs tight** to hub inner surface.

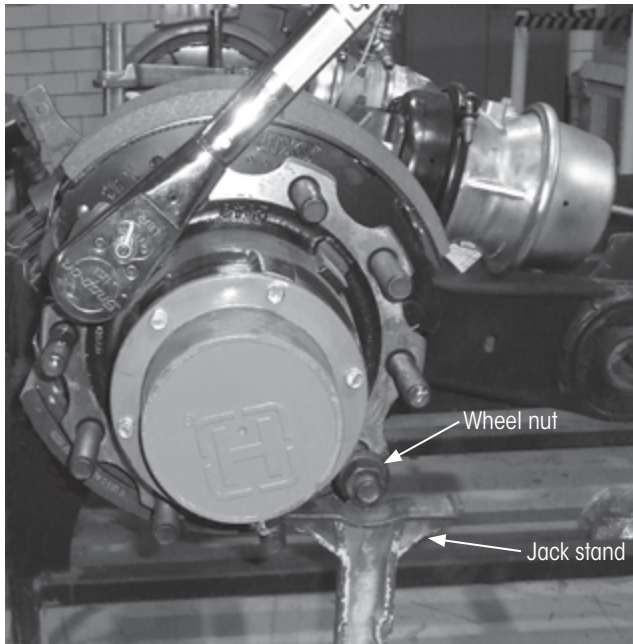

Figure 6: Stud draw-in process

- Complete stud draw-in process using a **torque wrench** set to 300 ft. lbs. (407 Nm) (Figure 6). With threads protected by a nut, a jack stand can be used to prevent the hub from turning, as shown in Figure 6.

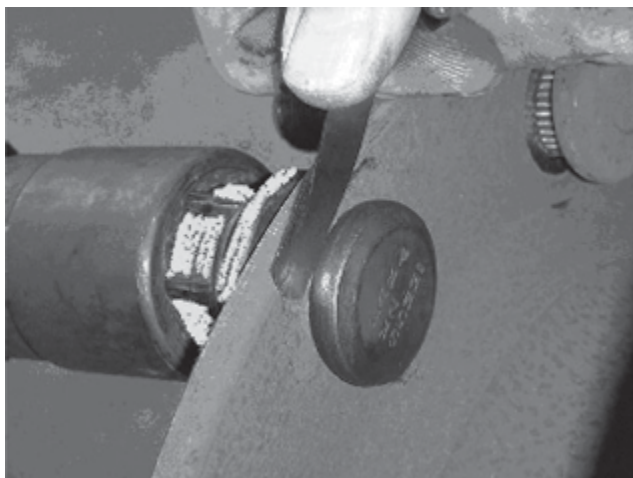

Figure 7: Checking stud installation

- Check** stud installation with a 0.0015 inch feeler gauge (Figure 7) to make sure the bolt is seated.
- Remove and discard** nut when done. **DO NOT reuse** this nut in new assembly.

## STUD MOUNTED U-SHAPED ROTOR TO HUB ASSEMBLY

Refer to Hendrickson literature number T71004 for procedures to remove and install the caliper.

**IMPORTANT:** DO NOT reuse torqued fasteners.

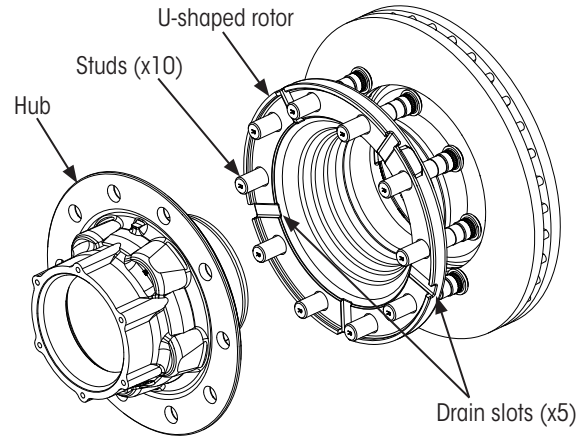

Figure 8: Hendrickson stud mounted hub & U-shaped rotor assembly

This rotor to hub assembly is clamped together using studs which are press fit into the U-shaped rotor and hub (Figure 8 and Figure 11). These procedures apply to complete disassembly and reassembly when removed from the spindle.

## HUB AND ROTOR DISASSEMBLY

To disassemble, all studs must be removed as follows:

**NOTE:** For replacing broken or damaged studs, the procedures starting on page 3 can also be applied.

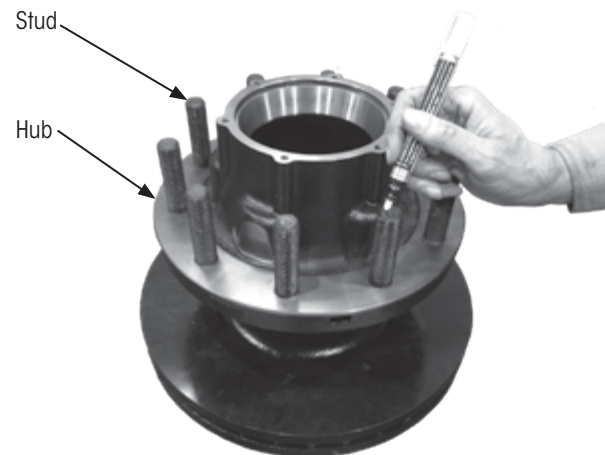

Figure 9: Identifying old studs

- Place** the hub and rotor assembly on a sturdy surface with the studs facing up (Figure 9).





2. **Mark** each of the old studs with a paint stick or other suitable marker. This will prevent old studs from getting mixed up with new studs.

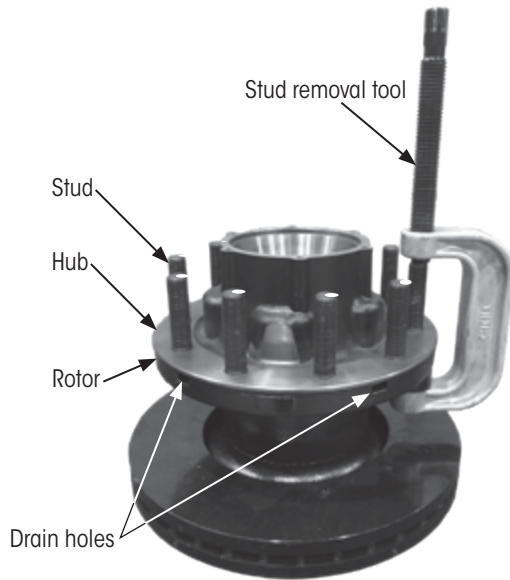

Figure 10: Pressing out old studs

3. Using a hydraulic press or stud removal tool (Figure 10), **press out** each stud. Once all the studs have been removed, the hub and rotor can be separated.

**IMPORTANT:** If replacing damaged or broken studs, to maintain wheel-end integrity, Hendrickson recommends replacing the adjacent stud on each side of the removed stud(s).

### ASSEMBLING HUB AND ROTOR

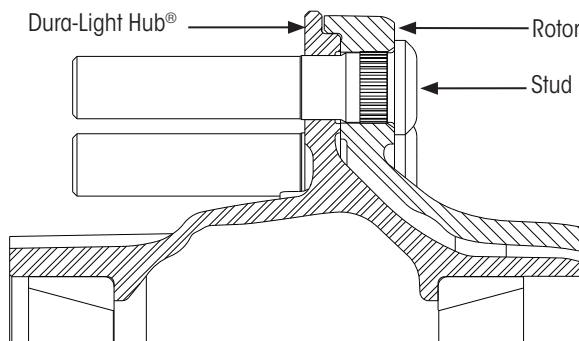

Figure 11: Hub and rotor assembly

As shown in Figure 11, the hub and rotor are held together by the studs. The knurled base of the stud is press fit into the rotor, while the non-knurled portion is press fit into the Dura-Light Hub®.

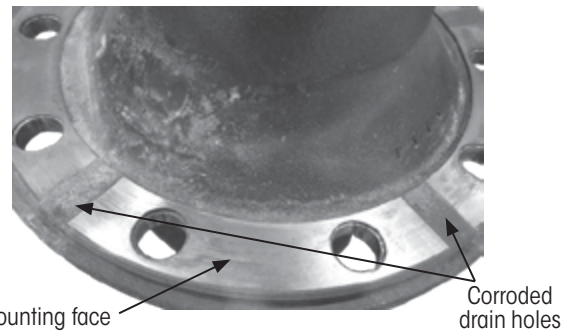

Figure 12: Drain hole corrosion on a used hub

### NOTICE

If installing a used hub onto a new rotor, corrosion may exist on the used hub pilots and where the drain holes were located (Figure 8, Figure 10 and Figure 12). This corrosion needs to be thoroughly cleaned off with a wire brush or emery cloth before assembling the hub and rotor. It is also recommended to align the hub and rotor such that the drain slots on the rotor mounting face are located in the same position to the hub mounting face as in the original assembly (Figure 10).

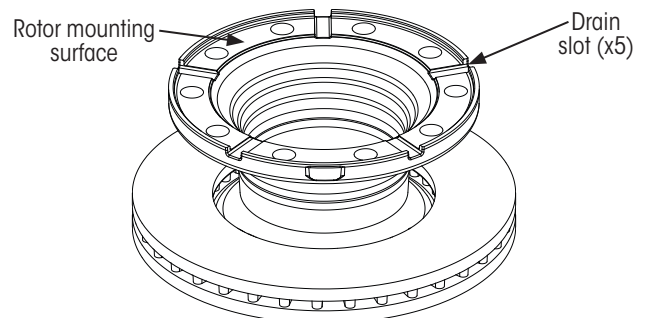

Figure 13: Stud mounted rotor

1. **Place** the rotor on a sturdy surface with the hub mounting surface facing up.

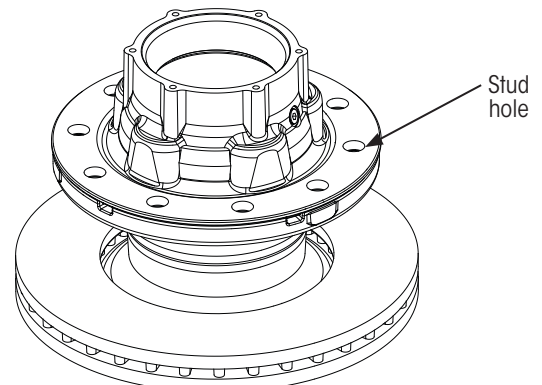

Figure 14: Aligning hub and rotor

2. **Gently place** the hub on the rotor mounting face and carefully align the stud holes (Figure 14).

**NOTICE** Ensure the hub seats flush to the rotor mounting face and pilots (Figure 11). If not correctly seated, the hub and rotor connection may loosen and cause damage to one or more wheel-end components.

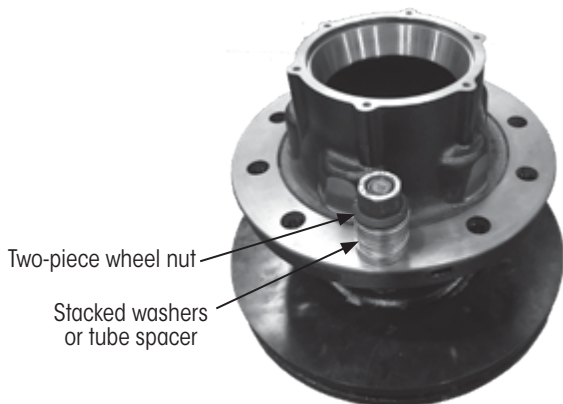

Figure 15: Stacked hardened washers and wheel nut

3. **Install** each stud into the assembly using a wheel nut and either a stack of hardened washers or a tube spacer (Figure 15).
4. **Obtain** a good condition matching nut or two-piece flange nut and **place** on the newly installed stud.

**NOTE:** A two-piece flange wheel nut or standard nut and hardened washer can be used for this purpose. The nut must be discarded at the end of this procedure. If using a two-piece flange wheel nut, the flange must rotate freely.

**IMPORTANT:** **DO NOT** lubricate threads. Doing so will reduce the friction between fastener components which can lead to overtightening, unpredictable clamp loads and an unreliable fastener connection.



Figure 16: Stud draw-in process

5. **Draw** studs tight by tightening the wheel nut with a ½ inch drive impact wrench (Figure 16).

**NOTICE** Use a different wheel nut to install each stud. Heat distortion from using a common wheel nut can damage the stud and nut threads after repeated use.

6. Using a torque wrench, **tighten** the wheel nut to 300 ft. lb. (405 Nm) of torque.
7. **Check** stud installation with a 0.0015 inch feeler gauge (Figure 7) to ensure the stud is fully seated.

If the feeler gauge indicates the stud has not fully seated, repeat steps 5 and 6.

**IMPORTANT:** Do not apply more than 500 ft. lbs. (678 Nm) of torque.

**NOTICE** Replacement of the hub is recommended if the any of the stud holes are worn or cracked, or if the hub face or pilots are worn or damaged.

8. **Remove and discard** nut when done. **Do not reuse** this nut for wheel assembly.



## WHEEL TO HUB ASSEMBLY

Axle track is the measurement from center of wheel(s) to center of wheel(s) on an axle. Drum and ADB hubs are designed to produce the same axle track when assembled to an axle.

## HUB PILOTING

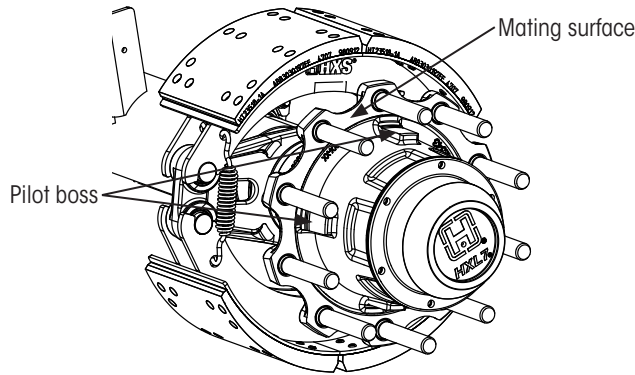

Figure 17: Sample hub piloted wheel-end (Drum brake hub shown)

All Hendrickson hubs are hub piloted (Figure 17). With the hub pilot system, pilot bosses (which are machined into the hub) center the brake drum and wheel around the hub.

## WHEEL ASSEMBLY

The entire wheel assembly is fastened together by a single two-piece flange nut on each wheel stud for both single and dual wheel applications. Figure 18 and Figure 19 show the difference between drum and ADB hub pilots.

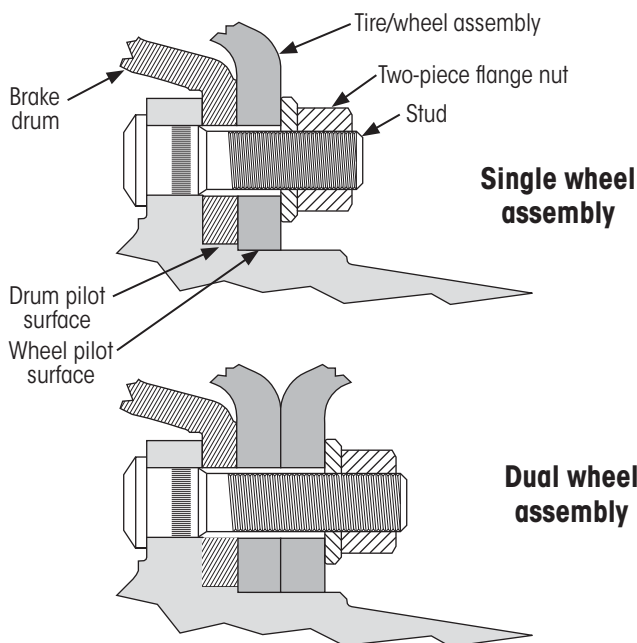

Figure 18: Drum hub piloted wheel mounting system

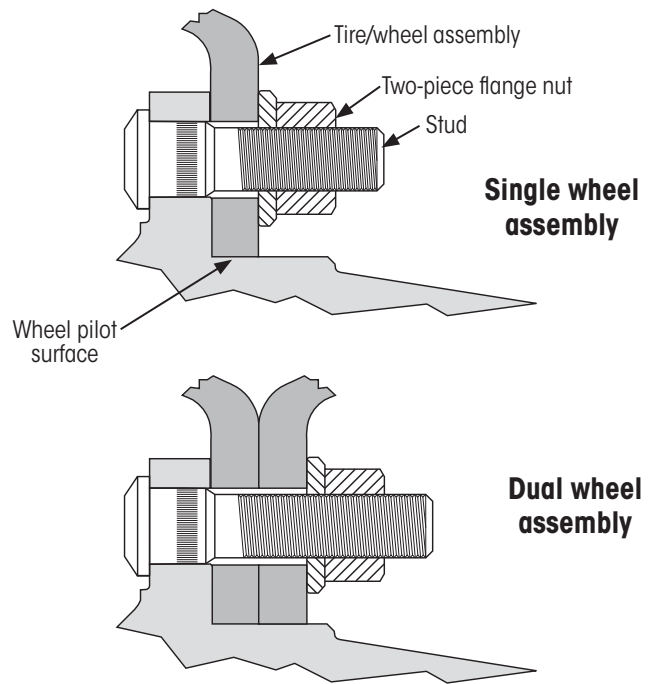

Figure 19: ADB hub piloted wheel mounting system

## WHEEL ASSEMBLY PROCEDURES

The following information is intended to provide basic brake drum and wheel installation instructions. Finer details such as whether or not to use a corrosion inhibitor, whether or not to lubricate the hub pilots, use a wheel dolly or sling, etc., are left to the reader's discretion. Refer to hub or wheel manufacturer's installation instructions and your company's maintenance, service and installation practices for complete installation details.

**WARNING** Read and follow the outlined instructions when installing or servicing the hub. Improper installation could result in property damage, injury, or death.

1. **Clean** all mating surfaces on hub, drum, wheels and nuts.
2. **Rotate** hub so a pilot boss (Figure 17) is at the top (12 o'clock) position.
3. **Mount** brake drum on hub so it fully seats on drum pilot and against hub face (Figure 18).

If reusing two-piece flange nuts, apply one drop of SAE 30W motor oil on the beginning two or three threads of the stud and apply two drops at the point between the flange and hex of the nut.

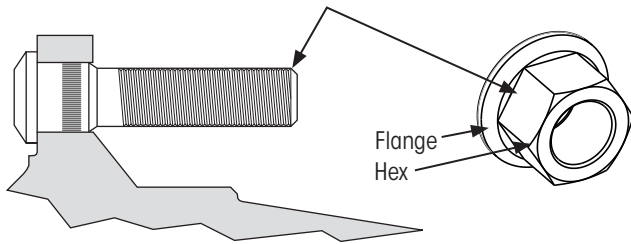

Figure 20: Lubricating stud and two-piece flange nut

4. Before reusing two-piece flange nuts that have already been used in service:
  - A. **Inspect** the nut to ensure it is in good condition and the flange continues to rotate freely. If not, discard and replace with new.
  - B. **Apply** one drop of SAE 30W motor oil on the beginning two or three threads of the stud.
  - C. **Apply** two drops at the point between the flange and hex of the nut (Figure 20).
5. **Mount** wheel(s) on hub. Wheel nuts can be started in order to hold wheel and drum into position.
6. **Snug** top (12 o'clock) and bottom (6 o'clock) wheel nuts and apply 50 ft. lbs. (68 Nm) of torque to draw wheel and brake drum fully against the hub.
7. **Inspect** to ensure proper assembly with wheel and brake drum positioned on pilot bosses before installing remaining wheel nuts.
8. Using sequence shown in Figure 21 and Figure 22, **tighten** all wheel nuts to 50 ft. lbs. (68 Nm) of torque.
9. Repeating sequence shown, **retighten** all wheel nuts to a **final torque of 475±25 ft. lbs. (645±30 Nm)**.
10. **Check** seating of wheel and brake drum at the pilot bosses. Rotate wheel and check for any rotational irregularity.

**CAUTION**

Any time a wheel nut is removed, it should be re-torqued after 50 to 100 miles of service.

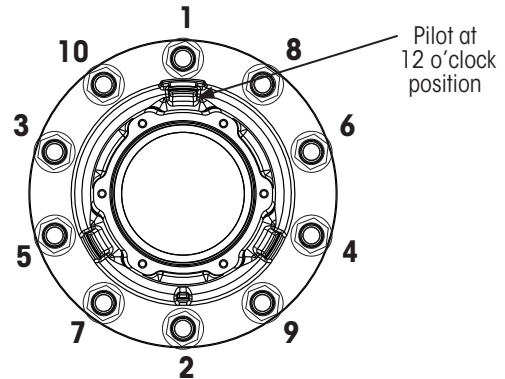

Figure 21: 10 stud tightening sequence

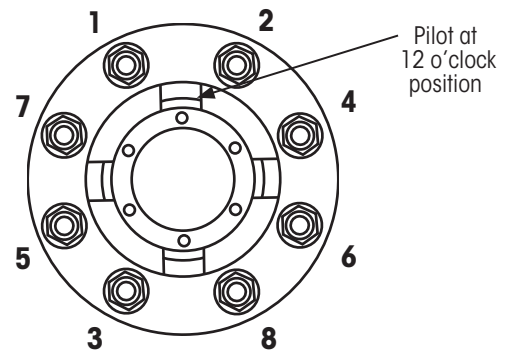

Figure 22: 8 stud tightening sequence

Actual product performance may vary depending upon vehicle configuration, operation, service and other factors.

Call Hendrickson at **866.RIDEAIR (743.3247)** for additional information.



www.hendrickson-intl.com

**TRAILER COMMERCIAL VEHICLE SYSTEMS**  
 2070 Industrial Place SE  
 Canton, OH 44707-2641 USA  
 866.RIDEAIR (743.3247)  
 330.489.0045 • Fax 800.696.4416

**Hendrickson Canada**  
 250 Chrysler Drive, Unit #3  
 Brampton, ON Canada L6S 6B6  
 800.668.5360  
 905.789.1030 • Fax 905.789.1033

**Hendrickson Mexicana**  
 Circuito El Marqués Sur #29  
 Parque Industrial El Marqués  
 Pob. El Colorado, Municipio El Marqués,  
 Querétaro, México C.P. 76246  
 +52 (442) 296.3600 • Fax +52 (442) 296.3601