

TECHNICAL PROCEDURE

TRAILER SUSPENSION SYSTEMS

SUBJECT: RS AdVANtage® and SmartRide
Service Manual

LIT NO: L1030

DATE: January 2009

TABLE OF CONTENTS

General Information	2
Model Identification	3
Part Identification	5
Proper Suspension Operation	6
Inspection Procedure	6
Slider Maintenance	9
Suspension Maintenance	10
Dock Height Support (DHS) Actuator	11
Pressure Regulator Valve	12
Pressure Protection Valve	12
Automatic Dump Valve	13
Height Control Valve (Hadley or Haldex Versions)	13
Height Control Valve replacement procedure	14
Ride Height Adjustment	15
Air Spring Removal	16
Air Spring Replacement and Installation	18
Shock Absorber Replacement and Installation	19
Pivot Connection	20
Pivot Bushing Removal and Installation	21
Suspension Axle	25
Alignment Method for AdVANtage	26
Check Body Rail Specifications	28
Torque Specifications	32
Appendix	33

INTRODUCTION

Hendrickson presents this publication to aid in maintenance and overhaul of the RS AdVANtage and SmartRide trailer suspension systems.

For any questions call Hendrickson Technical Service Department at 800-455-0043 in the United States or 800-668-5360 in Canada.

GENERAL INFORMATION

The description and specifications contained in this service publication are current at the time of printing.

Hendrickson reserves the right to discontinue or modify its models and / or procedures and to change specifications at any time without notice.

IMPORTANT NOTICE

Any reference to brand names in this publication are made as an example of the types of tools and materials recommended for use and should not be considered an endorsement. Equivalents may be used.

 This symbol is used throughout this manual to call attention to procedures where carelessness or failure to follow specific instructions may result in personal injury and / or component damage.

Departure from the instructions, choice of tools, materials and recommended parts mentioned in this publication may jeopardize the personal safety of the service technician or vehicle operator.

 **WARNING: FAILURE TO FOLLOW INDICATED PROCEDURES CREATES A HIGH RISK OF PERSONAL INJURY TO THE SERVICING TECHNICIAN.**

 **CAUTION: Failure to follow indicated procedures may cause component damage or malfunction.**

 **IMPORTANT:** Highly recommended procedures for proper service of this unit.

NOTE: Additional service information not covered in the service procedures.

ALWAYS USE GENUINE HENDRICKSON PARTS

Hendrickson recommends following all manufacturers' recommendations for the proper handling and disposal of lubricants and solvents. For further information contact the supplier of lubricants and solvents.

 **CAUTION: Welding or machining on any axle component is prohibited unless noted otherwise in this document.**



TRAILER SUSPENSION IDENTIFICATION

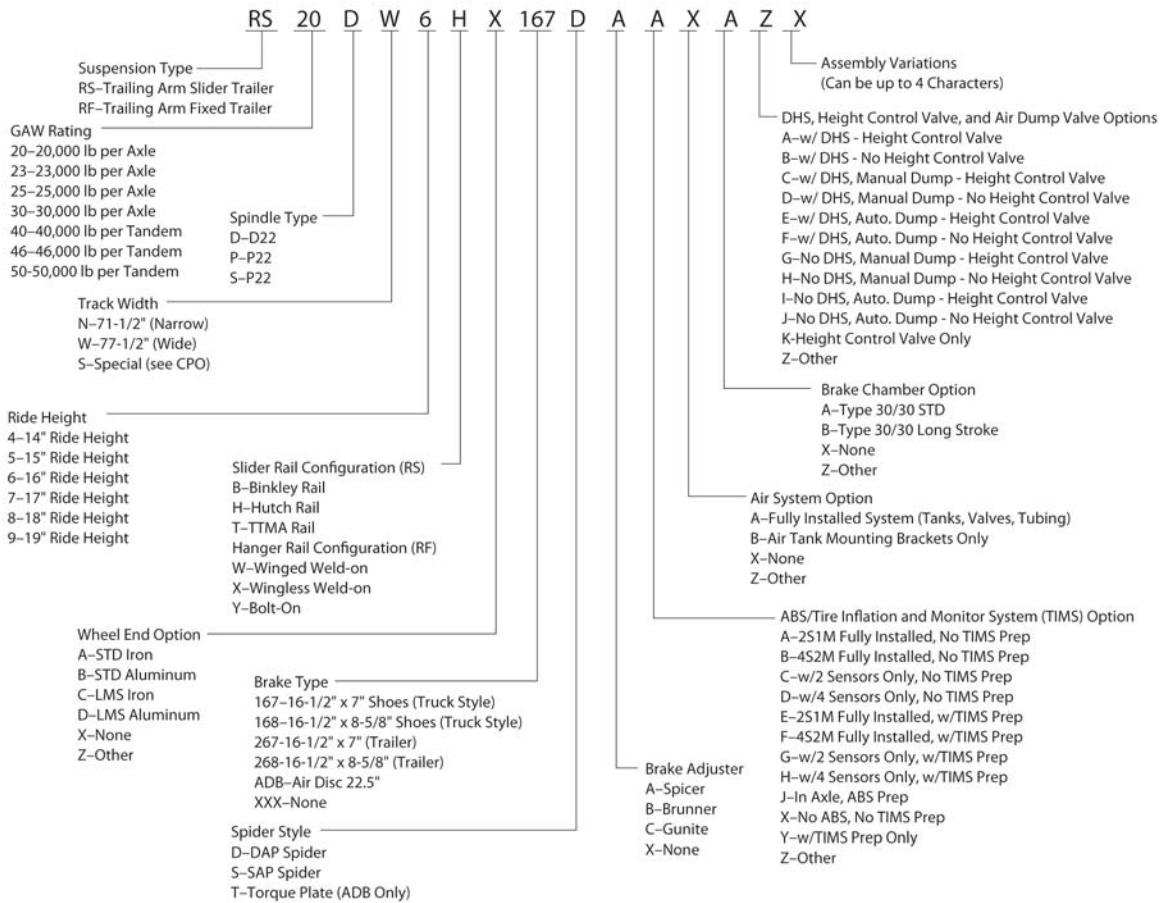

TRAILER AXLES PART NUMBER

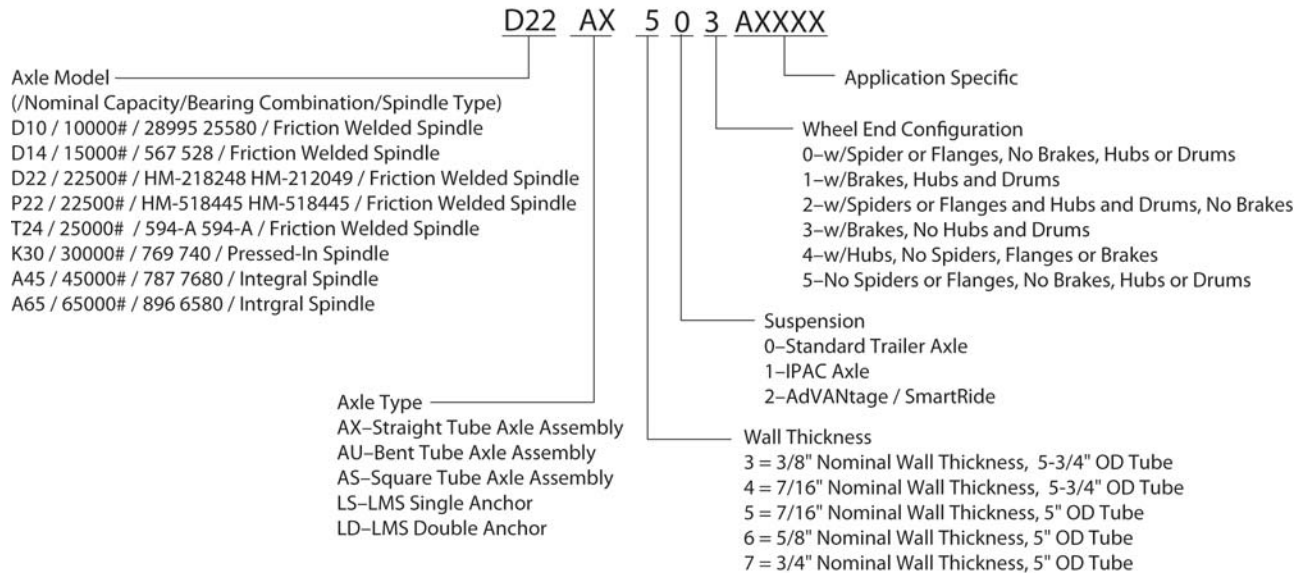



PART IDENTIFICATION

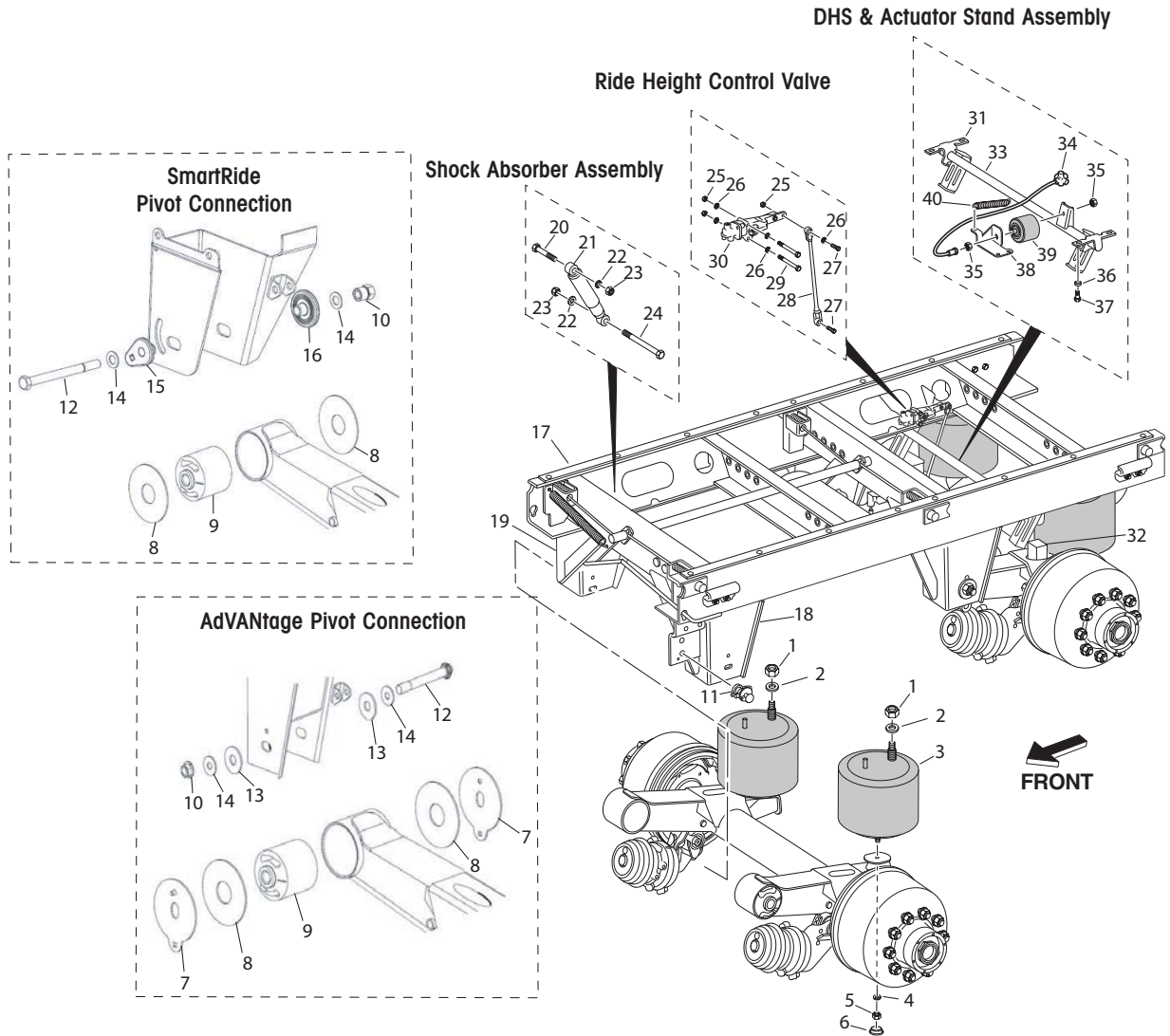

- 1 - Air bag lock nut
- 2 - Lock washer
- 3 - Air bag, suspension
- 4 - Air bag lock washer
- 5 - Chart-nut, hex jam
- 6 - Cap plug
- 7 - Washer, cam alignment
- 8 - Wear washer
- 9 - Bushing, pivot
- 10 - Lock nut, pivot
- 11 - Valve, air dump
- 12 - Bolt, pivot bolt
- 13 - Washer flat, pivot bolt
- 14 - Hardened washer
- 15 - Alignment cam
- 16 - Alignment washer

- 17 - Slider, box assembly
- 18 - Left hand hanger bracket
- 19 - Right hand hanger bracket
- 20 - Bolt shock, upper shock
- 21 - Shock absorber
- 22 - Washer flat, upper and lower shock
- 23 - Upper and lower shock nut
- 24 - Lower shock bolt
- 25 - Ride height valve nut
- 26 - Ride height valve washer
- 27 - Bolt, ride height pivot
- 28 - Linkage, ride height valve
- 29 - Bolt, ride height valve

- 30 - Valve, ride height control
- 31 - Bracket, pivot dock lock
- 31 - DHS base
- 33 - DHS stand assembly
- 34 - Valve, pressure regulator
- 35 - Lock nut, DHS actuator
- 36 - Flat washer, DHS kick stand
- 37 - Bolt, DHS kick stand
- 38 - Bracket, DHS actuator
- 39 - DHS actuator
- 40 - Return spring, DHS



PROPER SUSPENSION OPERATION

Hendrickson air suspensions covered in this manual are controlled by a single height control valve.

When properly adjusted, the height control valve will maintain a constant ride height by controlling the air pressure in the air springs to support the load being carried.

The trailer air pressure must be maintained in excess of 75 psig (5.2 bar) before operation. The 75 psig (5.2 bar) is required to open the air pressure protection valve, which maintains safe air brake pressure in the event of air loss in the suspension system.

NOTE: If equipped with a DHS system, the kickstand assembly will need to be manually disengaged before the suspension can be lowered onto the air springs internal bumpers.

⚠ CAUTION: Be sure tires are not rubbing the underside of the trailer or any other components.

⚠ WARNING: TO PREVENT SERIOUS EYE INJURY, ALWAYS WEAR PROTECTION WHEN PERFORMING VEHICLE MAINTENANCE OR SERVICE.

It is important to schedule physical and visual inspections based on severity of operation.

During each pre-trip and safety inspection of the vehicle, perform a visual inspection of the suspension.

Listen for air leaks and visually check for:

- Bolt movement - loose dirt, rust or metal wear around bolt head and nut
- Air springs - wear damage and proper inflation
- Shock absorbers - leaking or damaged
- Cracked parts or welds

⚠ CAUTION: Always block wheels to prevent roll away when working under the vehicle.

INSPECTION PROCEDURE

Prior to placing unit in service, check the following items:

1. Build air pressure above 75 psig (5.2 bar). With the vehicle shut off, check for air leaks.
2. With vehicle on level surface and air supply pressure in excess of 75 psig (5.2 bar), check air springs for equal firmness.
3. Check shock absorbers for proper installation. Torque bolts to 210-235 ft. lbs. (285-319 N•m).
4. Check for 1³/₄" (44 mm) minimum clearance around air springs with vehicle loaded.
5. Ride height should be within 1/₈" (3 mm) of recommended height measured from bottom of frame to centerline of axle. Refer to your specific model for proper ride height measurement.
6. Verify torque on pivot nuts to 700-800 ft. lbs. (950-1085 N•m) on AdvANTage 1¹/₈" bolt. Verify torque pivot bolts to 500-600 ft. lbs. (678-813 N•m) on SmartRide 7/₈" bolt.

Refer to the chart on the next page for inspection intervals.

**SUSPENSION INSPECTION CHART**

When (Frequency)	What (Activity)
Initial inspection	<ul style="list-style-type: none"> • Check and re-torque all bolts and nuts at the suspension and axle connections (See Note 1)
After first 5,000 miles (8,047 km)	<ul style="list-style-type: none"> • Check and re-torque other suspension related hardware (See Note 1)
Every 25,000 to 30,000 miles (43,233 to 48,279 km)	<ul style="list-style-type: none"> • Check brake lining wear and estimate required replacement date <ul style="list-style-type: none"> - Replace brake shoes and lining assembly when lining thickness is 1/4" (6mm) or less at thinnest point • Check brake shoes and lining assembly for damage <ul style="list-style-type: none"> - Replace immediately if lining is cracked, broken, or oil soaked • Check brake camshaft, spider bushing, and support bracket bushing for damage or wear <ul style="list-style-type: none"> - Replace or repair if any signs of damage or wear are discovered
Annually (from in-service date)	<ul style="list-style-type: none"> • Inspect all suspension components for wear or damage • Re-torque the pivot bolt connection [AdVANTage 700-800 ft. lbs. (950-1085 N•m)] [SmartRide 500-600 ft. lbs. (678-813- N•m)]
Every 100,000 miles (160,930 km) or whenever brake reline service is performed	<ul style="list-style-type: none"> • Check and re-torque all bolts and nuts at the suspension and axle connections (See Note 1) • Check and re-torque all other suspension related hardware (See Note 1) • Perform a thorough and complete inspection of the entire suspension assembly (See Note 2) <ul style="list-style-type: none"> - To prevent failure, tighten, repair, or replace any parts or components found to be loose, damaged, or worn • Replace wheel bearing lubricant (if specified) <ul style="list-style-type: none"> - NOTE: LMS wheel ends have a five year lubricant change requirement • Check spring brake chambers and slack adjusters • Inspect brake rollers, anchor pins, and bushings (Replace as required). • Check brake shoes for bent shoe ribs, cracks in shoe table welds or ribs and elongated rivet holes. Replace if any of the conditions described are found

NOTE 1: See "Torque Specifications" on page 32.

NOTE 2: See "Inspection Procedure" on page 6.

TRAILER SUSPENSION INSPECTION INTERVALS AND SUGGESTIONS

1. Inspections of trailer components should be performed routinely to locate problems early and prevent possible damage.
2. Normal inspection should be performed as a pre-trip and a post-trip inspection per Federal Driver Regulations for daily trip inspections. During each trip, drivers are required to inspect vehicle at every rest stop or every four hours.
 - Good inspection habits include observing the vehicle upon initial walk-up. A trained eye can catch a small problem before it turns into a big one
 - Every inspection should include a visual inspection of all components related to the trailer suspension
 - Visually check for leaks at the wheel ends or seal ends, loose or rusted fasteners, broken or cracked supports, frame and mounting hardware. Check hoses and wire for cracks, leaks or chafing
 - Visually confirm the proper engagement of all four slider pins from the slider box through the holes in the slider rails

 **CAUTION: Verification of pin engagement is critical after sliding the suspension for any reason.**

Failure to ensure proper slider pin engagement of the four pins can lead to severe damage to the slider box.

- Slide assemblies should be checked for missing hold down clips and any loose or missing bolts, pins or retainers
 - Axle oil levels should be checked for proper fill if equipped with a sight glass
 - Air tanks should be drained daily to eliminate water contamination that may affect the air or brake system
3. Routine service should be performed at regular oil change intervals, biannually and annually
 4. Other inspections should be performed at the OEM's recommended service cycle.

SLIDER MAINTENANCE

⚠ WARNING: ALWAYS CHECK FASTENER TORQUES, TIGHTEN LOOSE FASTENERS, OR REPLACE DAMAGED FASTENERS. LOOSE, DAMAGED, OR MISSING FASTENERS CAN CAUSE LOSS OF VEHICLE CONTROL, DAMAGE TO COMPONENTS, SERIOUS PERSONAL INJURY, OR DEATH.

1. Inspect the slider for loose, broken or missing fasteners. Repair or replace as needed. See torque specifications section.
2. Check the slider locking pins, slider pull-bar mechanism, and slider wear pads for signs of excessive wear or binding and proper engagement. Repair or replace as necessary.
3. Inspect the structure of the slider box and cross members for damage. Repair as needed.
4. Inspect the front and rear slider hold down clips to ensure that they are secured correctly around the body rails.

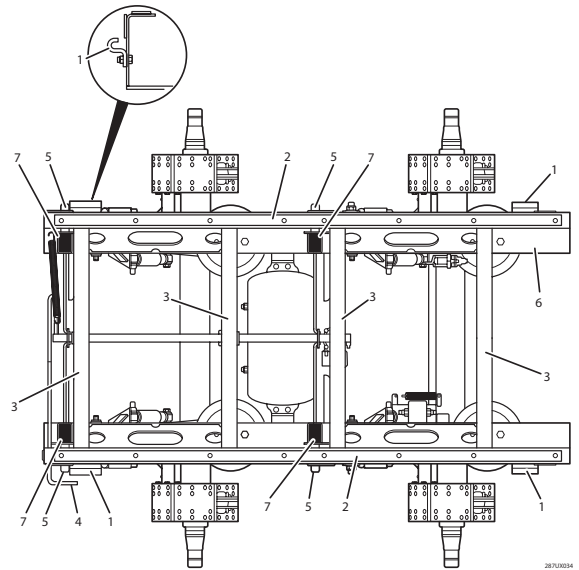

- 1 - Slider hold down clips (4)
- 2 - Slider wear pads (2)
- 3 - Cross members (4)
- 4 - Slider pull-bar handle
- 5 - Slider locking pins (4)
- 6 - Slider box
- 7 - Springs (4)

SUSPENSION MAINTENANCE

⚠ WARNING: CHECK FASTENER TORQUE VALUES, TIGHTEN LOOSE FASTENERS AND REPLACE DAMAGED FASTENERS. LOOSE, DAMAGED, OR MISSING FASTENERS CAN CAUSE LOSS OF VEHICLE CONTROL, DEATH, SERIOUS PERSONAL INJURY AND DAMAGE TO COMPONENTS.

1. Inspect for loose, broken or missing fasteners. Repair or replace as needed. See torque specifications section.
2. Inspect welds for cracks at the axle, frame bracket, pivot, gussets and hanger attachment.
3. Inspect bushings and bushing tube spacer for ragged or loose pieces that can protrude from the connection area. Refer to Hendrickson publications B106, *Pivot Bushing Inspection Procedure* and L750, *Bushing Tube Spacer Inspection / Replacement Procedure* for more information.
4. Inspect the rubber part of the air spring for cuts and abrasions. Replace the air spring if it is cut or damaged.
 - Inspect pivot bolt connections for movement. See "Pivot Connection"
 - If equipped, inspect for proper operation of the DHS. See "Dock Lock" information on pages 11 and 12
5. Check for obstructions or interference to the air spring surface that can damage the air spring. Relocate and secure items, such as air hoses, that can contact the air spring.

⚠ CAUTION: The air spring surface must be free of interference or obstructions by items such as tires, loose steel, etc. Damage to components can result from abrasion.

6. Check for leaks in the air lines, at the air spring bead plate, piston, and mounting studs. Replace air lines, fittings or air springs that leak. See height control valve section.

7. Inspect shock absorbers for worn bushings, oil leaks and dents. Check that mounting holes have not enlarged.
8. After normal operation, check shocks for heat as follows:
 - Warm shocks most likely indicate the shocks are operating correctly
 - Cold shocks can indicate that the shocks are not operating correctly and must be replaced. Replace shocks and bushings as necessary
9. Inspect the structure of the suspension for possible road damage including:
 - Axle welds
 - Frame bracket to frame welds or frame bracket to mounting plate welds
 - Brake interference (cam or chamber)
 - Frame brackets
 - Shock brackets
 - Frame bracket support gusset connections

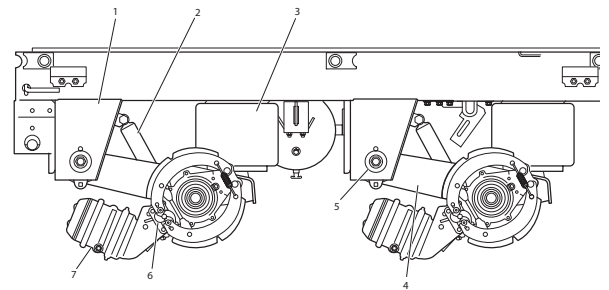

- 1 - Frame bracket
- 2 - Shock absorbers
- 3 - Air springs
- 4 - Trailing arm axle and arm weldment
- 5 - Pivot bolt
- 6 - Brake cam
- 7 - Brake chamber

DOCK HEIGHT SUPPORT (DHS) ACTUATOR

REMOVAL AND REPLACEMENT

Before removing or replacing DHS you must park unloaded vehicle on a leveled surface and block wheels. Be sure that you drain air tanks before you begin.

1. Lift and support trailer by sub frame, allowing suspension to hang off the ground.
2. Locate the DHS actuator and verify the actuator and trailer air system tanks are drained.
3. With the DHS actuator deflated, the DHS kick stand should be in the engaged position (vertical).
4. Remove air supply line to the actuator and remove attaching nut and bolt from each end.
5. Note the actuator orientation and remove.
6. Install replacement actuator in the same orientation as noted in step 5.
7. Remove jack stand. Recharge air system.
8. Apply and release spring brakes. Observe DHS actuator operation. Make sure actuator movement is not restricted.
9. Check for leaks and repair as required.

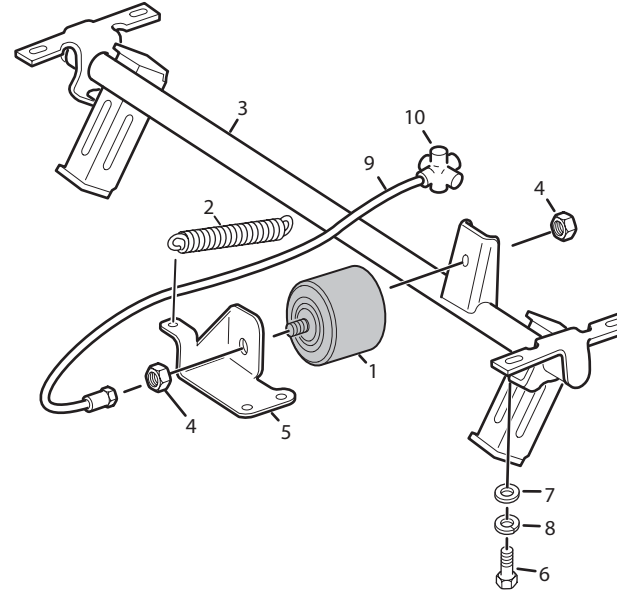

NOTE: Operating pressure for the DHS actuator is 25psi +/- 5 psi

- 1 - DHS actuator
- 2 - Spring
- 3 - DHS kick stand
- 4 - Retainer nut
- 5 - Bracket
- 6 - Bolt (4)
- 7 - Washer (4)
- 8 - Lock washer (4)
- 9 - Air line
- 10 - Pressure regulator valve

DHS KICK STAND

Before removing or replacing DHS you must park unloaded vehicle on a leveled surface and block wheels. Be sure that you drain air tanks before you begin.

1. Lift and support trailer by sub frame, allowing suspension to hang off the ground.
2. Remove the spring (2) from the frame bracket (5).
3. Remove nut (4) that attaches the actuator to the DHS kick stand.
4. Remove the fasteners holding the cross shaft mounting bracket on one side.
5. Remove the kick stand by sliding it out of the bracket on opposite side.
6. Replace the kick stand in reverse order.
7. Recharge the air system and cycle trailer emergency (red) air line.
8. Observe the kick stand for proper operation.

⚠ WARNING: TO CHECK OPERATION, ENSURE ENGAGEMENT WITH TRAILER PARKING BRAKES AND THEN RELEASE ONLY THE TRAILER PARKING BRAKE. OBSERVE OPERATION AND VERIFY DISENGAGEMENT.

Use caution while inspecting the DHS. Stay clear of suspension pinch points and moving parts on the DHS system.

PRESSURE REGULATOR VALVE

Before removing or replacing DHS you must park unloaded vehicle on level surface. Be sure that you drain air tanks before you begin.

1. Locate the DHS actuator and follow air line from bag to regulator valve (regulator valve mounted to sub frame of axle assembly).
2. Remove the air lines from the valve.

3. Remove the two attaching bolts from the valve. Remove the valve (valve is non-serviceable).
4. Replace valve and reassemble in reverse order.
5. Supply trailer with air. Check for leaks. Repair as required.

NOTE: This valve limits the operating pressure supplied to the actuator to 25 psi +/- 5 psi.

PRESSURE PROTECTION VALVE

The pressure protection valve (PPV) is located at the air reservoir. It supplies the ride height valve with air pressure and protects the system reservoir from being completely drained, in the event of a failure in the air ride suspension, allowing the brake system to remain operational.

To test, remove outlet line to the ride height valve. With system pressure above 75 PSI air should flow through the PPV, at system pressure below 75 PSI the PPV will automatically close and stop air flow from the supply tank.

If air continues to flow and drain the air supply tank or does not function properly, replace the PPV.

⚠ WARNING: NEVER REMOVE THE PPV FROM THE SYSTEM OR SUPPLY AIR DIRECTLY TO THE HEIGHT CONTROL VALVE FROM THE RESERVOIR BY BYPASSING THE PPV.

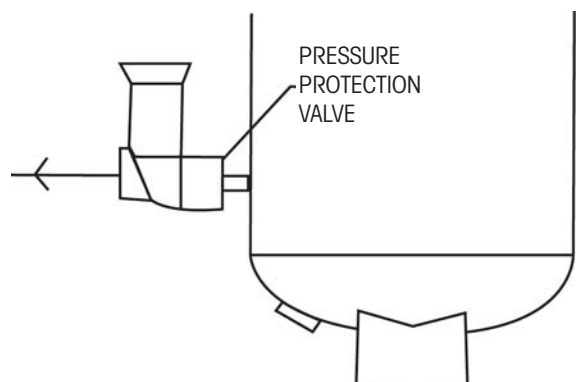

AUTOMATIC DUMP VALVE

The valve maintains solid vertical trailer floor height during loading and unloading. When the parking brake is engaged, the valve exhausts air from the air springs and lowers the suspension to the bump stops, which are three inches lower than the design height or to the DHS support stands when used in combination with the DHS Automatic Dump.

⚠ CAUTION: When the combination of a DHS and Automatic Dump Valve are used, operators should make note of increased inflation time for the suspension and verify disengagement before operating.

HEIGHT CONTROL VALVE (HADLEY OR HALDEX VERSIONS)

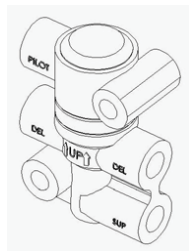

TEST PROCEDURE

1. Park the unloaded vehicle on a level surface.
 2. Secure the vehicle and block the wheels.
 3. Verify that the pivot point on both ends of the linkage rotates freely (does not bind).
- ⚠ CAUTION:** Failure of the pivot points to rotate freely about the fastener will result in damage to the linkage, brackets, or suspension and can prevent proper operation of the ride height valve to maintain the correct ride height of the suspension.
4. Verify the ends are secure. Loose ends will slip allowing the suspension to raise or lower beyond the ride height settings.
 5. If pivot point binding or loose ends are found, correct the problem. If the height control valve still does not operate properly, go to step 6.

6. Disconnect the height control linkage.

Haldex Style Valve

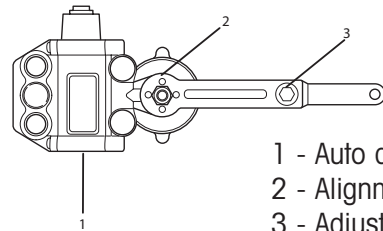

- 1 - Auto dump (integral)
- 2 - Alignment indicator
- 3 - Adjustment bolt

Hadley Style Valve

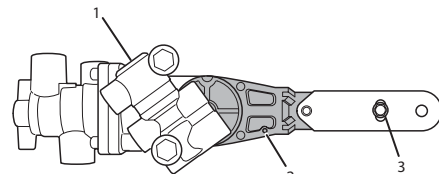

- 1 - Auto dump
- 2 - Locating pin hole
- 3 - Adjustment bolt

⚠ WARNING: VERIFY THAT PEOPLE ARE CLEAR OF THE TRAILER BEFORE INFLATING OR DEFLATING THE AIR SPRINGS. THE AIR SUSPENSION HAS VARIOUS PINCH POINTS THAT CAN CAUSE SERIOUS PERSONAL INJURY.

7. Check the air supply to the height control valve. A minimum of 75 psig (5.2 bar) is typically required to correctly test the height control valve.
8. Rotate the lever up 30- to 45-degrees. With a delay style valve, air should begin to flow into the air springs between two and six seconds. Non delay height control valves begin airflow in less than one second.
9. Rotate the lever to the neutral position. Airflow should stop.
10. Rotate the lever down 30- to 45-degrees. Air should begin to flow out of the air springs exhausting at the height control valve in two to six seconds for a delay style valve. Non-delay height control valves begin to exhaust in less than one second.
11. Rotate the lever to the neutral position. Airflow should stop.

⚠ CAUTION: Do not add lubrication or cleaning solvents to the air system. These additives can contaminate the air system.

12. If the air does not flow to and from the air springs, drain the air from the system. Disconnect air lines to the height control valve. Use compressed air to clean the screens in the supply and delivery ports of the height control valve.
13. Connect the air lines to the height control valve and repeat steps 4-11. If air still does not flow to and from the air springs, or if the airflow cannot be stopped in the neutral position, replace the height control valve.
14. Inspect the height control valve for air leaks or damage. If air leaks or damages are detected, replace the height control valve.

HEIGHT CONTROL VALVE REPLACEMENT PROCEDURE

⚠ WARNING: TO PREVENT SERIOUS EYE INJURY, ALWAYS WEAR EYE PROTECTION WHEN PERFORMING VEHICLE MAINTENANCE OR SERVICE.

Replace worn or damaged components with genuine replacement parts. Installation of non-genuine parts can cause serious personal injury and damage to components.

Verify that people are clear of the trailer before inflating or deflating the air springs. The air suspension has various pinch points that can cause serious personal injury.

1. Park the unloaded vehicle on a level surface.
2. Secure and block the wheels.
3. Drain all air from the supply tank and air springs. Exhaust air from the system by opening the drain valve at the bottom of the supply air tank to remove supply air pressure.
4. Remove air supply and delivery lines from the height control valve to be replaced.
5. Disconnect the linkage. Inspect for damage and replace bent or damaged linkage.

6. Detach the height control valve from the bracket.
7. Attach the new height control valve to the mounting bracket. Tighten the mounting bolts (5 ft. lbs. [7 N•m]).
8. Insert the locating pin in the lever arm of the height control valve (See "Locating Pin Hole" in step 5 on page 15). On the Haldex style valve, verify the alignment indicator is at the 12 o'clock position.
9. Reconnect the linkage. Tighten the upper and lower linkage bolt (5 ft. lbs. [7 N•m]).
10. Apply a thread sealant to the pipe threads and install in the valve. Reattach the air supply and delivery lines.
11. All connections must be free of leaks. Avoid sharp bends in airlines. Recharge air system to a minimum of 75 psig (5.2 bar).
12. Using a soapy spray solution, check the entire system for air leaks.
13. Remove the locating pin at the lever arm of the height control valve. (Hadley style valve)
14. Check ride height and adjust as described in "Ride Height Adjustment."

Early AdvANTage

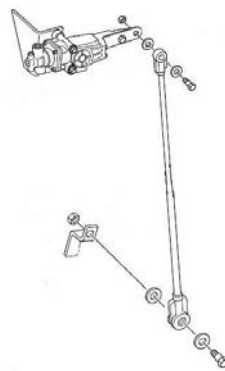

Later AdvANTage and SmartRide

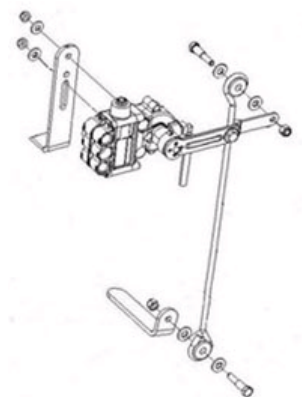

RIDE HEIGHT ADJUSTMENT

⚠ WARNING: OVERALL TRAILER HEIGHT OR CARGO HEIGHT MUST NOT EXCEED 13.50 FT. (4114 MM). IF VEHICLE CANNOT CLEAR BRIDGE UNDER PASSES DURING OPERATION, SERIOUS PERSONAL INJURY AND DAMAGE TO COMPONENTS WILL RESULT.

Ride height adjustment must be done on level ground.

1. Unload the trailer before adjusting the height control valve. Support the trailer king pin at the normal operating height.
2. Determine the correct ride height. As specified by the 7th digit of the suspension part number, see Introduction section of this manual, measure ride height from the centerline of the axle to the bottom of the slider frame (14-19" [355-483 mm]).

⚠ WARNING: VERIFY ALL PERSONNEL ARE CLEAR OF THE TRAILER BEFORE INFLATING OR DEFLATING THE AIR SPRINGS. THE AIR SUSPENSION HAS VARIOUS PINCH POINTS THAT CAN CAUSE SERIOUS PERSONAL INJURY.

3. Inflate or deflate the air springs by raising or lowering the height control lever arm 30- to 40-degrees.
4. Check the ride height (per drawing below).

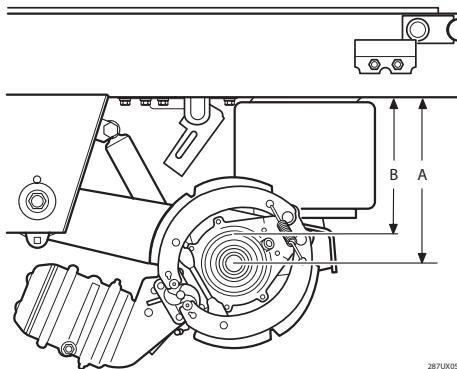

A- Ride height measurement
B- Ride height - 1/2 diameter of axle

HADLEY RIDE HEIGHT VALVE

5. Insert the locating pin or a 1/8" (3.2 mm) drill bit at the level arm of the height control valve.

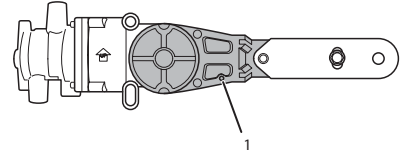

287U0052

1 - Locating Pin Hole

6. Loosen the 1/4" (6.4 mm) adjusting bolt located on the lever arm body. Allow the lever arm to swing free.

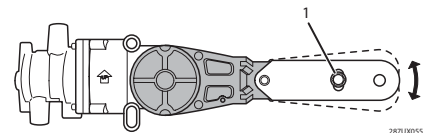

287U0055

1 - Adjusting Bolt

7. Align the end of the lever arm to the top opening of the linkage. Loosely insert the upper linkage bolt.

HALDEX RIDE HEIGHT VALVE

8. Position the alignment indicator at the 12 o'clock position as shown in the diagram.

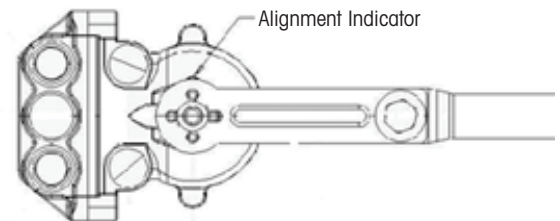

9. Loosen the 1/4" adjusting bolt located on the lever arm.
10. Align the center of the linkage bolt hole on the end of the lever arm with the center of the upper linkage bolt hole.

HALDEX AND HADLEY RIDE HEIGHT VALVES

11. Tighten the 1/4" (6.35 mm) adjusting bolt.
12. Remove the locating pin or 1/8" (3.2 mm) drill bit.

⚠ WARNING: VERIFY ALL PERSONNEL ARE CLEAR OF THE TRAILER BEFORE INFLATING OR DEFLATING THE AIR SPRINGS. THE AIR SUSPENSION HAS VARIOUS PINCH POINTS THAT CAN CAUSE SERIOUS PERSONAL INJURY.

If equipped with a DHS system, verify proper engagement and disengagement after setting the ride height.

13. Connect the upper linkage bolt. Tighten the bolt to 5 ft. lbs. (7 N•m).

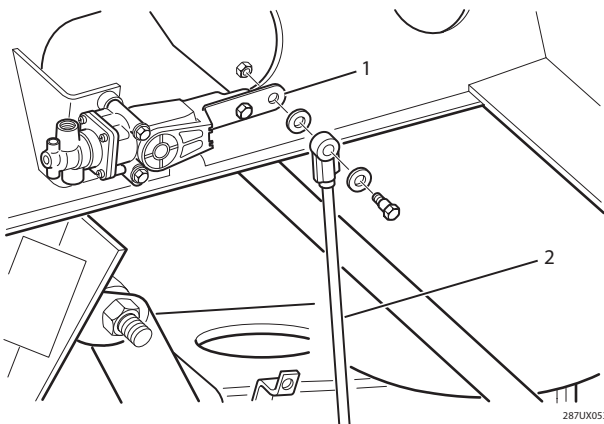

- 1 - Ride Height Arm
- 2 - Valve Linkage

14. Check to verify that trailer height or cargo height does not exceed 13.50 ft. (4114 mm). If ride height is not within specification, repeat steps 1-10 to adjust ride height. Verify that ride height is correct.

NOTE: If ride height is correct, then an over-height trailer is not the problem of the suspension. Gross over-height should not be corrected by lowering the ride height. At the normal position, there is only 2 1/2" (63.5 mm) of up travel.

AIR SPRING REMOVAL

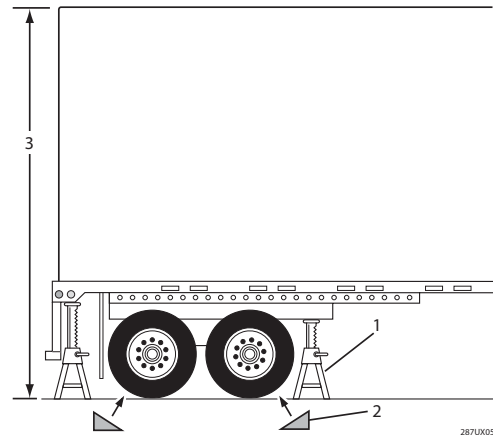

- 1 - Support Trailer
- 2 - Block Tires
- 3 - Trailer Height

⚠ WARNING: BLOCK THE WHEELS TO PREVENT THE VEHICLE FROM MOVING. SUPPORT THE VEHICLE WITH SAFETY STANDS. DO NOT WORK UNDER A VEHICLE SUPPORTED ONLY BY JACKS. JACKS CAN SLIP OR FALL OVER. SERIOUS PERSONAL INJURY CAN RESULT.

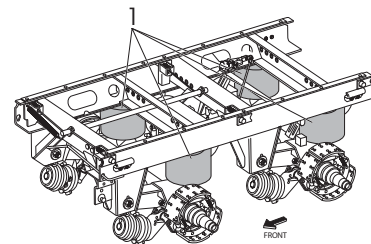

- 1 - Air spring (4)

1. Identify the specific air spring that is damaged or leaking air.
2. Block the tires to prevent forward and backward movement of the trailer.
3. Raise and securely support the rear of the trailer with safety stands.

⚠ WARNING: VERIFY ALL PERSONNEL ARE CLEAR OF THE TRAILER BEFORE INFLATING OR DEFLATING THE AIR SPRINGS. THE AIR SUSPENSION HAS VARIOUS PINCH POINTS THAT CAN CAUSE SERIOUS PERSONAL INJURY.

4. With the trailer raised and securely supported, exhaust all air from the system by opening the valve at the bottom of the supply air tank to remove supply air pressure.

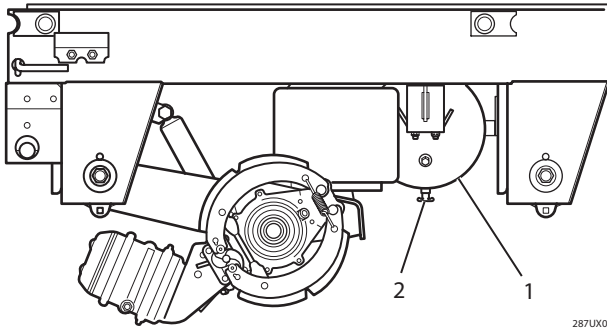

287UX066

- 1 - Air tank
- 2 - Drain valve

5. Remove the valve linkage and exhaust all air from the air springs by moving the valve arm down.

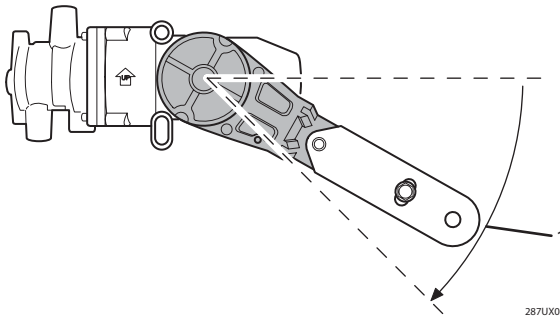

287UX049

- 1 - Air out rotate down 30- to 40-degrees

6. Remove the air inlet line and fitting from the damaged air spring (See Appendix for plumbing diagram).
7. Remove the nut from the stud that secures the top of the air spring.

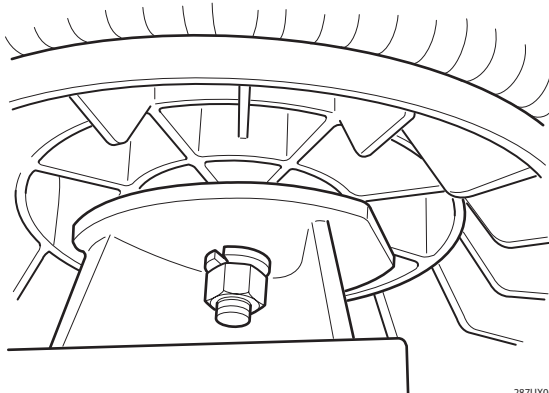

287UX007

8. Remove the nut from the bottom of the air spring. The nut can be reached from inside the upper axle seat or by removing the access plug and using an extension and socket.

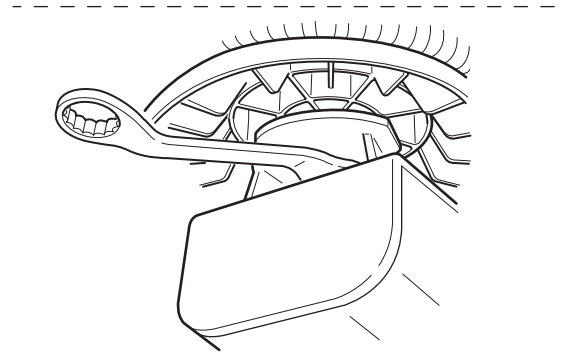
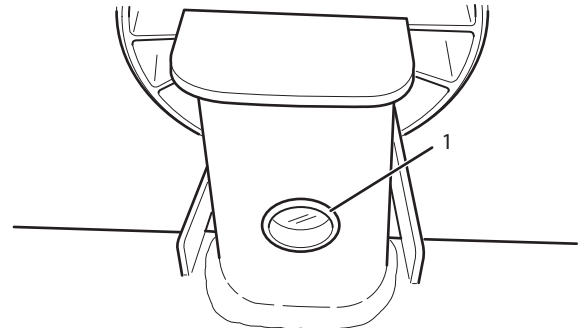

287UX008

- 1 - Access plug

9. Compress the air spring. Remove the spring from the suspension.

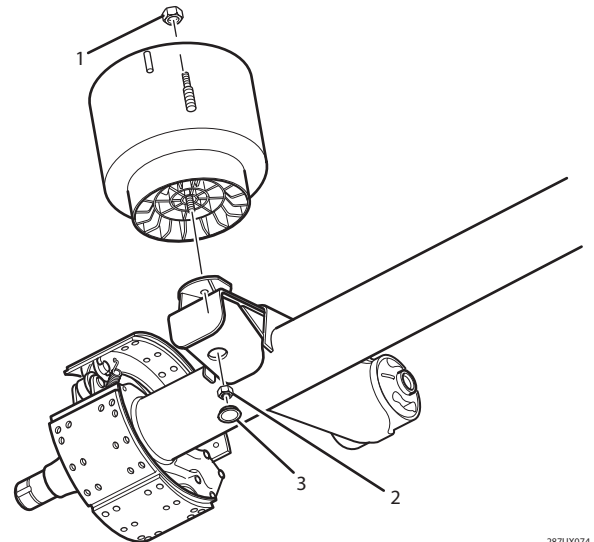

287UX074

- 1 - Upper air spring nut
- 2 - Lower air spring nut
- 3 - Access plug

AIR SPRING REPLACEMENT AND INSTALLATION

⚠ CAUTION: The air spring surface must be free of interference or obstructions by items such as tires, loose steel, etc. Damage to components caused by abrasion can result.

1. Compress the new air spring. Slide the spring into the space between the axle seat and slider frame.
2. Align the air inlet and mounting stud. Insert them into the holes in the slider frame.

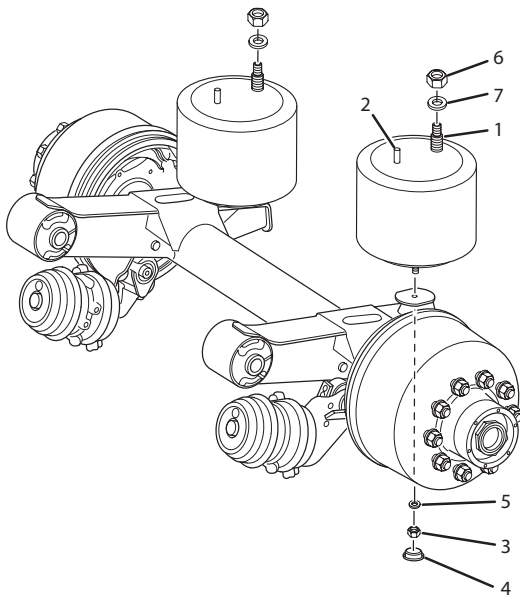

- 1 - Air inlet
- 2 - Mounting stud
- 3 - Lower nut
- 4 - Access plug
- 5 - Lock washer
- 6 - Upper nut
- 7 - Lock washer

3. Install the lower nut. Tighten the lower nut to 25-30 ft. lbs. (35-40 N•m).
4. Install the nut on the air inlet and tighten. Tighten the nut to 45 ft. lbs. (60 N•m).
5. Install the fitting and inlet air line to the top of the air spring using a thread sealant.
6. Close the valve at the bottom of the air tank. Pressurize the air system.

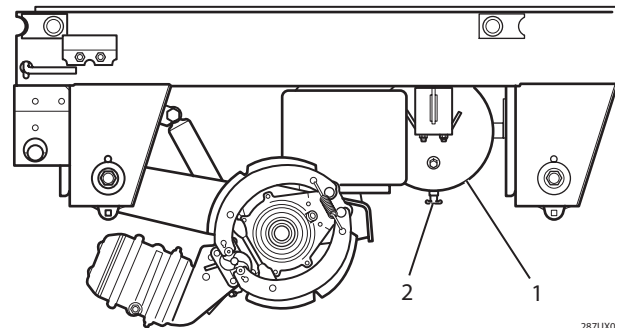

- 1 - Air tank
- 2 - Drain valve

7. Check the tires, loose steel, etc. do not interfere with the rubber part of the air spring.
8. Use a soap solution to check the entire system for air leaks. Check all the air lines and the components as illustrated in the air system diagram in the Appendix. Pay particular attention to the air line connections at each component.
9. Raise the trailer. Remove the safety stands.
10. Verify that the ride height of the trailer is correct. If the ride height is incorrect, adjust the height control lever arm to obtain the correct ride height. Refer to the trailer OEM's specifications for the correct ride height and the previous section, "Ride Height Adjustment".

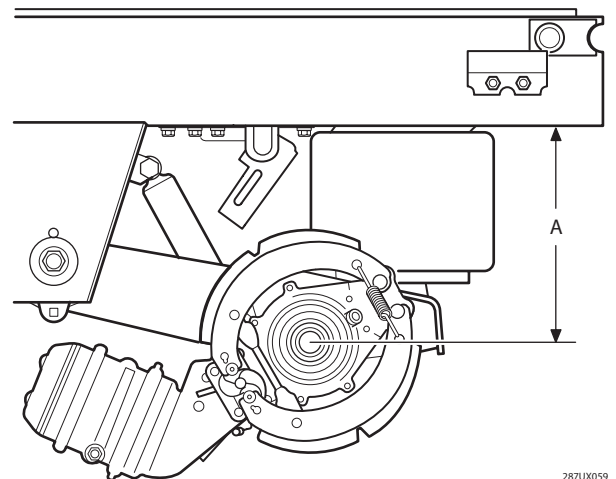

A - Ride height measurement

⚠ CAUTION: The tire clearance must be 1" from any suspension member when all air springs are deflated.

SHOCK ABSORBER REPLACEMENT AND INSTALLATION

Shock absorbers do not absorb shock, they absorb energy to prevent suspension oscillation. Shock absorbers are also used as rebound stops in most air suspensions. The shock absorber limits the stroke of an air spring, which prevents the air spring from being pulled apart. In some severe-service applications, an optional limiting strap kit is added to additionally aid in limiting over extension of an air spring.

1. Remove the upper shock mount bolt. Discard the fasteners.
2. Remove the lower shock bolt. Discard the fasteners.
3. Remove the shock absorber.

TO INSTALL A SHOCK ABSORBER:

1. Install shock with the dust cover / bell down.
2. For top mount:
 - a. Place the shock in the upper bracket.
 - b. Insert the bolt through the bracket and upper shock mount.
 - c. Install the washer and lock nut.
3. For bottom mount, place a washer on each side of the shock before inserting bolt. Insert bolt from inside of slider body with nut next to the frame.
4. Torque top and bottom bolt to 210-235 ft. lbs. (285-319 N•m) from inside.

⚠ CAUTION: Do not lift the trailer without the shock absorbers in place. If shock absorbers are not in place, over extension of the air springs will occur. Damage may occur to the over extended air springs.

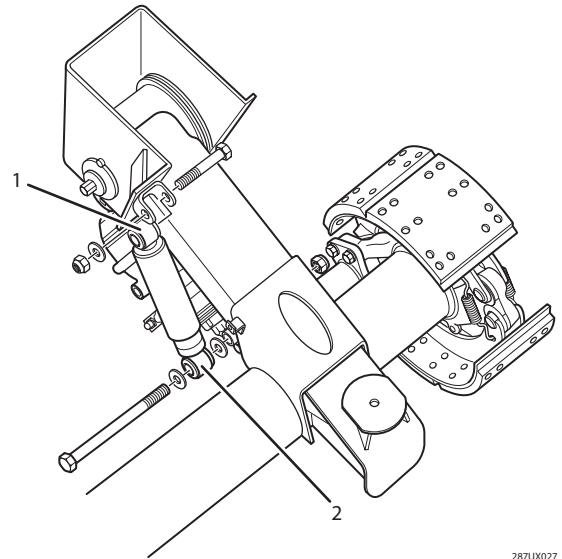

1 - Top mount
2 - Bottom mount

287UX027

PIVOT CONNECTION

A correct pivot connection is crucial to the life of the suspension. The pivot fastener must continually provide a sufficient clamp load through the bushing to prevent premature suspension failure.

ADVANTAGE

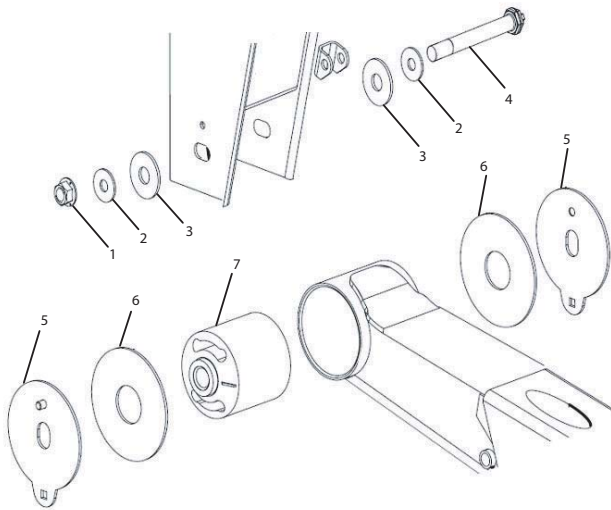

- 1 - Lock nut (pivot)
- 2 - Hardened washer
- 3 - Pivot washer
- 4 - Pivot bolt
- 5 - Alignment cam washer
- 6 - Wear washer
- 7 - Pivot bushing

SMARTRIDE

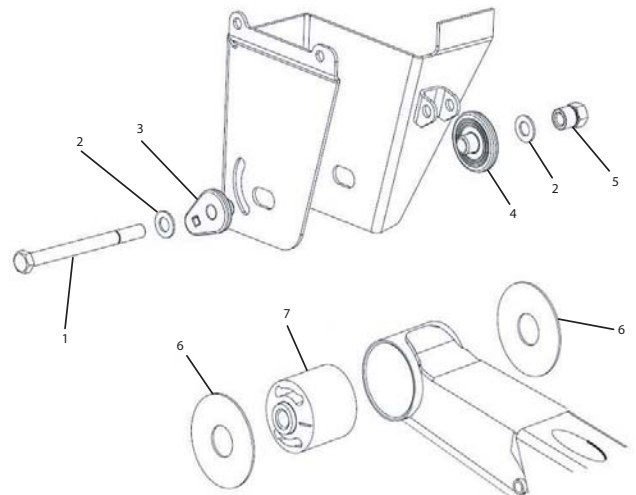

- 1 - Pivot bolt
- 2 - Hardened washer
- 3 - Alignment cam
- 4 - Alignment washer
- 5 - Shear nut
- 6 - Wear washer
- 7 - Pivot bushing

PIVOT BOLT

ADVANTAGE

Uses a 1 1/8" diameter bolt employing a shear head feature with an E-22 torx head socket to achieve the proper 700-800 ft. lbs. (950-1085 N•m) torque when assembling.

NOTE: Maintaining proper socket engagement during the shearing process is critical in achieving proper torque in the pivot bolt. See illustrations.



The following illustrations show the proper engagement of the socket, which must be maintained as the bolt is torqued and the head is sheared off (a 1" impact should deliver enough torque to shear the head).

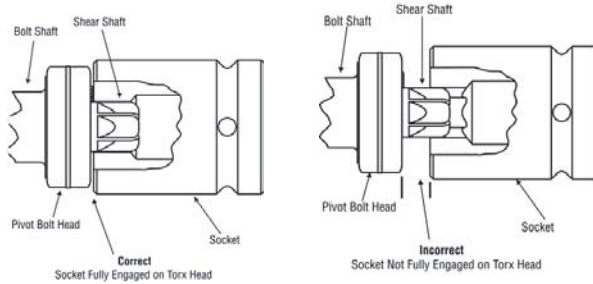

The following illustrations show the results that will be visible to verify that the connection has been secured properly.

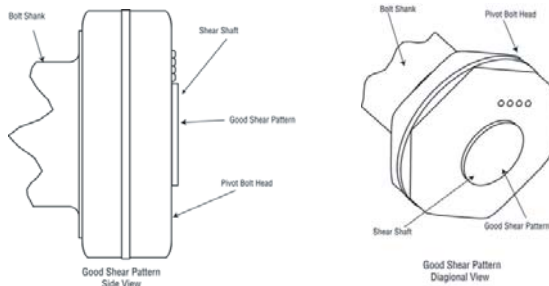

The following illustrations show the results that will be visible if the shear off procedure has taken place incorrectly. If this condition is found, even during routine inspections, contact the Hendrickson technical service department at 800-455-0043 in the United States or 800-668-5360 in Canada.

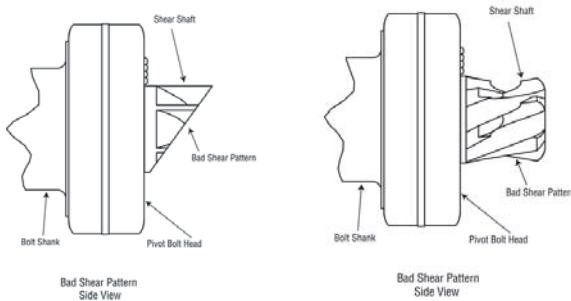

SMARTRIDE

Uses a 7/8" diameter bolt and a shear nut feature with a standard hex head which shears off during the torque procedure after achieving the proper torque. 500-600 ft. lbs.

NOTE: For both AdvANTage and SmartRide suspension models, it is recommended that a new bolt and nut are used when completing an axle alignment on the suspension systems.

PIVOT BUSHING

The pivot bushing has unique properties that will provide years of maintenance-free service. The bushing provides a resilient connection that allows an axle to walk without excessive flexing. The bushing, in conjunction with the rigid axle connection, results in a roll stable suspension design that resists trailer lean independent of the air spring loading.

There are times when a problem, seemingly in the area of the suspension, is diagnosed as a failed bushing. Closer inspection typically reveals another component or a faulty installation is the problem. If a problem is in the area of the suspension, see Diagnostics, or contact the Hendrickson technical service department. Refer to Hendrickson publications B106, *Pivot Bushing Inspection Procedure* and L750, *Bushing Tube Spacer Inspection / Replacement Procedure* for more information.

Re-bushing of a suspension requires the use of a bushing removal / installation tool and bushing kit, containing the required components for re-bushing. Contact Hendrickson technical service for assistance. When re-bushing the suspension, see the pivot bushing section below and also reference Hendrickson publication L427, *Bushing Replacement Procedure*.

BUSHING REMOVAL

1. Support the trailer and exhaust the air from the air springs.
2. Remove the nut from the pivot bolt. Remove the pivot bolt from the suspension and the suspension bracket. Lower the suspension trailing beam down and out of the suspension frame bracket. Carefully remove the inner alignment cam and the outer alignment cam. Discard the nut, bolt and wear spacer.
3. Before any bushing removal is attempted, chalk or scribe the bushing orientation on the beam tube to ensure proper positioning of the bushing for installation.

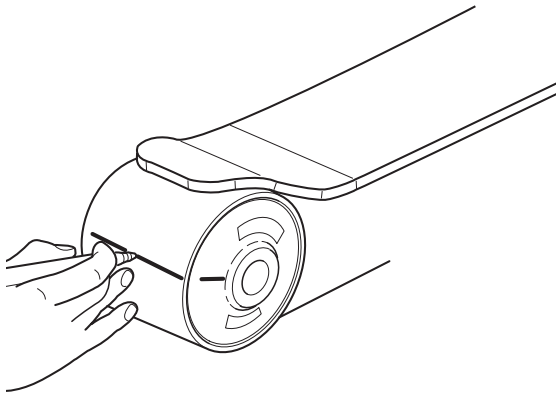

NOTE: Bushing voids must be located in the correct position. Voids must be on a vertical centerline when suspension is at ride height. Align indexing mark on the suspension beam with an indicator mark on the bushing. If the mark is not visible on the beam, be sure to install the voids in the same location as voids of the removed bushing.

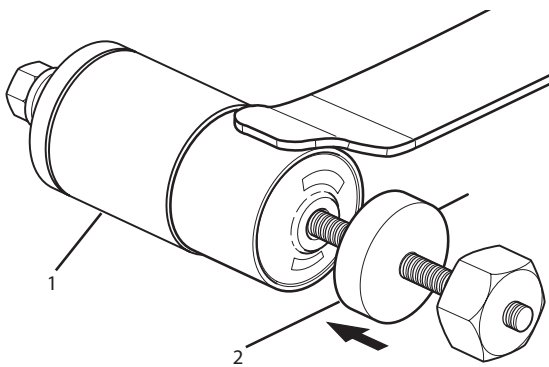

4. Install a bushing removal tool on the bushing tube at the pivot bushing. The tool must consist of a transition tube to receive the bushing as it is removed, and a remover that fits over the metal bushing bore to press the bushing out.

The end of the transition tube which receives the removed bushing will always be positioned against the suspension beam during bushing removal and installation. This will cause the bushing to elongate during either operation.

- 1 - Transition tube
- 2 - Remover

5. Apply high pressure lube to the threads of the bushing removal tool hex bolt.

⚠ CAUTION: Do not use pressure lube on the bushing. It is only to be used on the threads of the hex head bolt.

6. Insert the hex head bolt of the assembled tool through the bushing until the transition tube rests squarely on the bushing tube. Slide the remover over the exposed threads on the hex head bolt. Snug the hex head bolt while ensuring the transition tube rests squarely on the bushing tube.

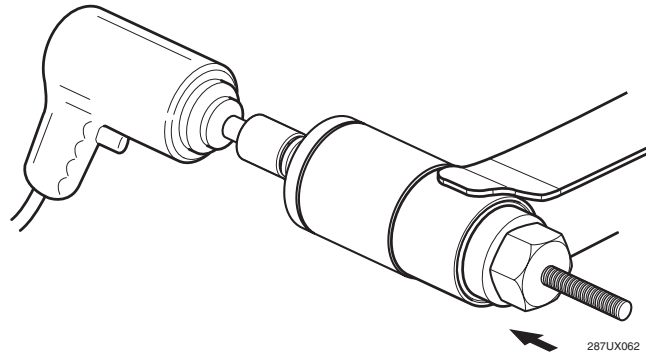

7. Turn the hex head bolt clockwise using a $\frac{3}{4}$ " impact wrench and a heavy-duty (6-point) impact socket. If the bolt stops turning during the removal process, reverse the impact wrench and loosen the tool assembly. Check parts for damage. Reset the remover and try again.

NOTE: Use of a 1" impact wrench is not recommended. Damage to the threads of the hex head bolt could result.

NOTE: Ensure the transition tube remains properly seated against the bushing during bushing removal.

NOTE: As a last resort, a small amount of heat may be required to break the bushing loose. Do not over heat the bushing tube. Allow the bushing tube to cool before installing the new bushing.

8. Typical removal time should be four minutes or less.
9. After bushing removal, reverse the impact wrench to disassemble the tool.

BUSHING INSTALLATION

1. Clean the bushing tube on the trailer suspension beam. All rust, rubber, and any other buildup must be removed before a new bushing can be installed. The bushing tube must be cool.
2. Check the edges of the bushing tube for burrs or sharp edges. Remove any burrs by grinding. If the edge of the tube is sharp, grind a small chamfer on the inside of the leading edge. This will aid wear pad life.

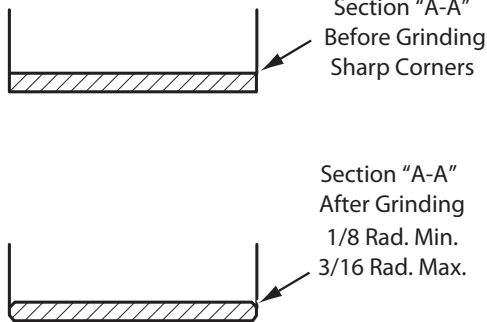
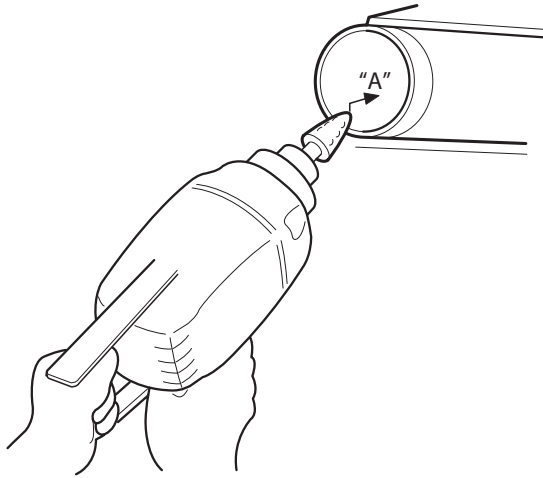

3. Lube the inside of the beam bushing tube, the outside diameter of the bushing and the inside of the transition tube of the bushing tool with Seagull type M, Cyclo-lube or an equivalent rubber assembly lube. Do not apply this lubricant to the threads of the bushing tool hex head bolt.

⚠ CAUTION: Do not use Petroleum based lubricant on the pivot bushing, Petroleum based lubricant will damage the bushing rubber.

4. Push the bushing into the transition tube and assemble the bushing tool.

NOTE: Ensure that the indicator mark on the bushing is aligned with the scribe mark on the transition tube. Ensure the thrust bearing is greased and the threads of the hex head bolt are well lubricated with high-pressure lube.

5. Push the bushing and transition tube assembly over the threads of the hex head bolt until they contact the beam bushing tube. The lips of the transition tube and front plate should rest on the lip of the beam bushing tube.

NOTE: The bearing cup end of the transition tube should be resting against the beam bushing tube so the bushing will elongate during the installation process.

NOTE: The transition tube should be oriented with the chalk mark or scribe mark made during disassembly.

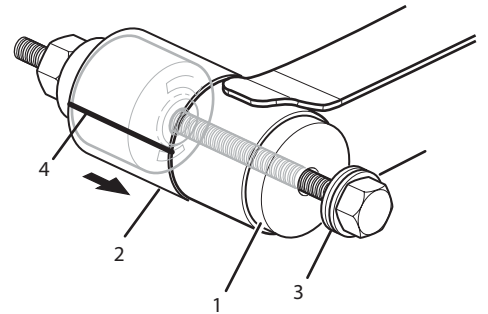

6. Hold the installer against the bushing and turn the hex head bolt to engage the threads of the nut.
7. Snug the hex head bolt and recheck the alignment of the beam bushing tube and the bushing tool.

- 1 - Installer
- 2 - Transition tube
- 3 - Thrust bearing
- 4 - Indicator mark

8. Use a $\frac{3}{4}$ " impact wrench and an impact socket to turn the hex head bolt. When the bushing is approximately halfway in the beam bushing tube, the impact wrench may slow down. After a very short time, the wrench will pick up speed again.

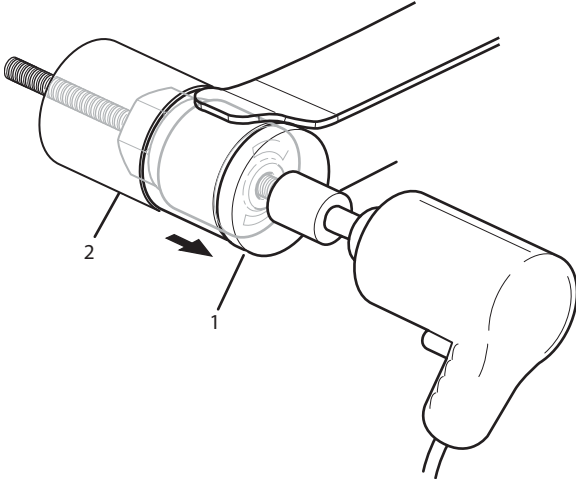

- 1 - Installer
2 - Transition tube

NOTE: If the installer is not sitting squarely on the bushing, rubber will work its way around the sides of the installer and stop any movement of the bushing. If the impact wrench stops, reverse the impact wrench and reset the installer on the bushing squarely.

9. The transition tube will fall away before the bushing is seated totally in the beam bushing tube. Continue to tighten until the bolt stops turning.

⚠ CAUTION: Do not allow the transition tube to fall or the tool could be damaged and personal injury could result.

NOTE: Do not over torque the hex head bolt or the bolt could be damaged.

10. Verify that the bushing is aligned with the scribe marks on the suspension beam tube.

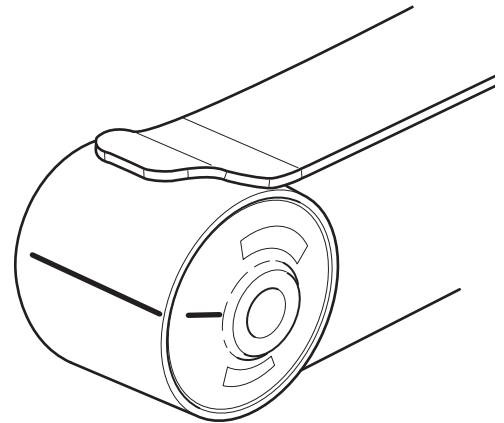

11. Disassemble and clean the tool. Store the tool in a clean dry area.

12. Reassemble the pivot connection. With fastener, snug only. Do not torque at this time.

13. Check alignment. Adjust if necessary.

⚠ CAUTION: Do not tack weld the bolt to the collar.

14. Use the shear feature on the bolt head for the AdvANTage suspension or manually torque to 700-800 ft. lbs. (949-1085 N•m). On the SmartRide suspension use the shear feature or manually torque to 500-600 ft. lbs. (678-813 N•m).

15. Verify alignment is correct after the torque process.

⚠ CAUTION: Failure to follow these procedures and / or to properly torque the pivot fasteners could result in a failed pivot connection and damage to the axle, suspension or trailer.

SUSPENSION AXLE

Alignment should always be done while the trailer is empty.

Proper preparation is a must for effective axle alignment. The vehicle, tools and equipment, and work site must all be appropriate for axle alignment. The process also requires a trained technician who knows the specifications.

Axle alignment specifications may be stated in inches, degrees, minutes of angle (MOA or 1/60th of a degree), or mm/M. Each format can produce equivalent results. Hendrickson Trailer Axles are built to less than +/- 2.5 MOA run out at each spindle.

ADJUSTMENTS

TMC RP 708, Trailer Axle alignment, addresses all the steps needed to make the trailer ready for alignment.

To review these:

- Inspect the suspension and the axles for any obvious damage
- Tighten, repair, or replace any parts that do not meet suspension or axle manufacturer criteria for serviceability
- Check tires for proper inflation and matching diameters
- Park the trailer on a smooth and level pad with the parking brakes released

NOTE: After backing the trailer in, pull it forward in a straight line to a gentle stop. This will allow suspension parts to settle in a "forward running" position. Use wheel chocks to prevent injury due to accidental movement of the trailer.

- With the brakes still released, adjust the height control valve for the proper setting and the upper coupler (bolster plate) to the proper height by raising or lower the landing gear legs
- Do not proceed unless the wheel bearing end play is known to be in adjustment per TMC's recommended procedure or the bearing manufacturer

Measure the distance from the trailer king pin to the centerline of the spindles on the first axles. It is recommended that a spindle extension be utilized. Dimensions A and B must be equal within 1/8" (3.2 mm). Dimension E is equal to the distance between the trailer centerline and the axle centerline.

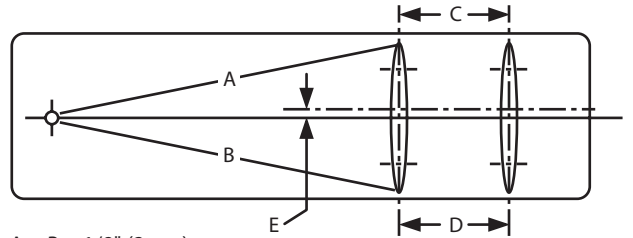

$$A = B \pm 1/8" (3\text{mm})$$

$$C = D \pm 1/16" (1.5\text{mm})$$

$$E < 1/16" (1.5\text{mm})$$

287UX071

Repeated difficulty in adjusting the axle to the desired reading is most often due to a loose wheel bearing, badly worn suspension component, or a combination.

⚠ WARNING: NEVER BEND THE AXLE IN ORDER TO CORRECT ANY ALIGNMENT CONDITION. THIS COULD WEAKEN THE AXLE AND CAUSE AXLE FAILURE RESULTING IN SERIOUS INJURY OR DEATH.

1. The trailer must be on a level surface.
2. Adjust the trailer landing gear. The height of the king pin should be the same as when the trailer is connected.
3. Release the parking brakes. Secure and block the wheels of the axle not being aligned to keep the locking pins tight against the same side of the body rail holes (front and rear).

ADVANTAGE

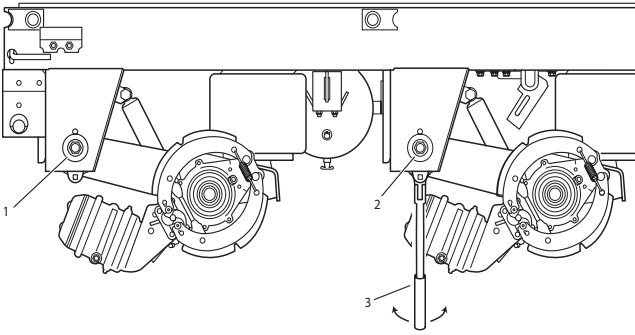

- 1 - Front pivot bolt head
- 2 - Rear pivot bolt head
- 3 - 1/2" drive pull handle

FIRST AXLE

1. Check to verify the suspension is at the correct ride height. Refer to the trailer OEM's specifications. Ride height information is also found in the 7th digit of the model number.
2. Measure from the king pin to each end of the first axle (measurements A and B). To obtain correct alignment, the dimensions must be with $\pm 1/8$ " (3.2mm) at both ends of the axle.
 - If adjustment is required, proceed to "Alignment Method"
 - If adjustment is not required, proceed to "Rear Axle"

REAR AXLE

1. Check the dimension from the centerline of the first axle to the centerline of the rear axle (measurements C and D).
2. The dimensions must be within $\pm 1/16$ " (1.5mm) at both ends of the axle.
 - If adjustment is required, proceed to "Alignment Method"

ALIGNMENT METHOD FOR ADVANTAGE

1. Start with the pivot connection nut snug torqued at this point.
2. Using a 1/2" drive pull handle to rotate the alignment washers to make necessary alignment adjustments.
3. Use the shear head feature on the bolt head or manually torque to 700-800 ft. lbs. (950 - 1085 N•m) on either side of the axle.
4. Verify alignment and repeat step 3 on opposite side of the axle.

The use of a new pivot bolt and lock nut is recommended when completing axle alignment.

NOTE: Hendrickson does not recommend the reuse of the pivot bolt, washers, or nut. The pivot bolt and nut are not reusable.

⚠ CAUTION: DO NOT apply an anti-seize compound to the pivot connection hardware or allow undercoating, paint, or any other commonly used compounds to contact the threads of the pivot connection fastener. These compounds can act like a lubricant, reducing the friction between the threads of the nut and bolt. This can lead to over-tightened fastener, unpredictable pivot connection clamp loads and unreliable axle alignments.

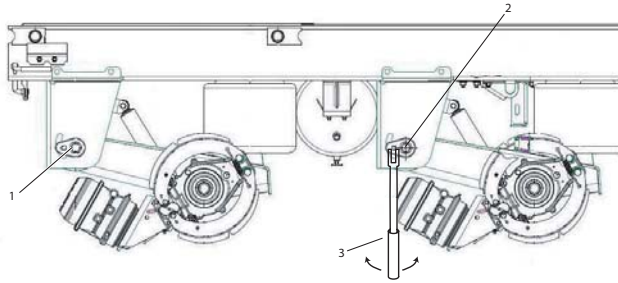
SMARTRIDE

- 1 - Front pivot bolt head
- 2 - Rear pivot bolt head
- 3 - 1/2" Drive pull handle

FIRST AXLE

1. Check to verify the suspension is at the correct ride height. Refer to the trailer OEM's specifications.
2. Measure from the king pin to each end of the first axle (measurements A and B). To obtain correct alignment, the dimensions must be within $\pm 1/8"$ (3.2 mm) at both ends of the axle.
 - If adjustment is required, proceed to "Alignment Method"
 - If adjustment is not required, proceed to "Rear Axle"

REAR AXLE

1. Check the dimension from the centerline of the first axle to the centerline of the rear axle (measurements C and D).
2. The dimensions must be within $\pm 1/16"$ (1.5 mm) at both ends of the axle.
 - If adjustment is required, proceed to "Alignment Method."

NOTE: Hendrickson does not recommend the reuse of the pivot bolt, washers, or nut. The pivot bolt and nut are not reusable.

ALIGNMENT METHOD FOR SMARTRIDE

1. Start with the pivot connection nut snug torqued at this point.
2. Using a 1/2" drive pull handle to rotate the alignment cam, make necessary alignment adjustments.
3. Use the shear nut feature or manually torque to 500-600 ft. lbs. (677-813 N•m) on either side of the axle.
4. Verify alignment and repeat step 3 on the opposite side of the axle.

⚠ CAUTION: DO NOT apply an anti-seize compound to the pivot connection hardware or allow undercoating, paint, or any other commonly used compounds to contact the threads of the pivot connection fastener. These compounds can act like a lubricant, reducing the friction between the threads of the nut and bolt. This can lead to over-tightened fastener, unpredictable pivot connection clamp loads and unreliable axle alignments.

CHECK BODY RAIL SPECIFICATIONS

⚠ WARNING: TO PREVENT SERIOUS EYE INJURY, ALWAYS WEAR EYE PROTECTION WHEN YOU PERFORM VEHICLE MAINTENANCE OR SERVICE.

Check the following dimensions on the trailer to ensure the trailer air suspension system correctly fits the trailer.

1. The distance between the trailer body rails must be $\frac{1}{8}$ " (3.2 mm) wider than the slider bearing surface to allow the slider to be placed securely between the body rails.

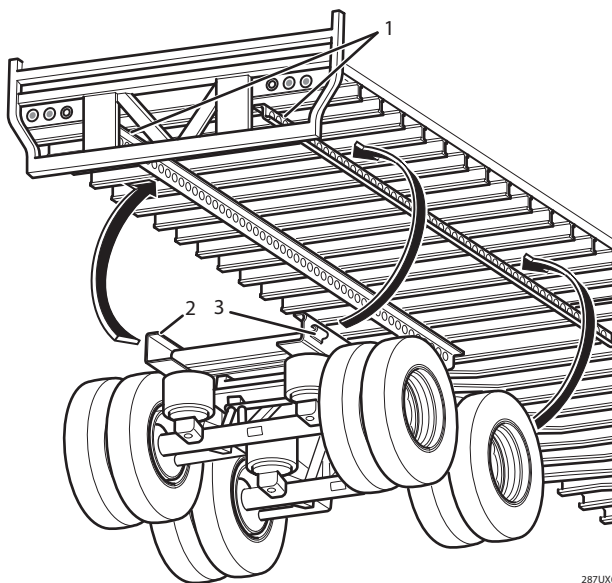

- 1 - Trailer body rails
- 2 - Slider bearing surface
- 3 - Slider hold down clips

2. The trailer body rail hole diameter must be $\frac{3}{16}$ " (4.8 mm) larger in diameter than the pin size to allow the slider pins to enter or retract from the body rail.
3. Verify the measurement from the centerline of the holes in the trailer body rail to the slider contact surface of the body rail is the same as the measurement from the centerline of the pins on the slider to the top of the wear strip.

4. To ensure the slider locking pins will slide through the body rails on both sides of the trailer:
 - The stationary stop bar at the rear of the trailer must be perpendicular to the body rails
 - The measurement from the rear of the slider to the center of the locking pins matches the hole spacing in the body rails when the slider is against the rear stationary stop bar
 - The stop bar notches at the front of the slider align with the holes in the body rails

RETROFIT INSTALLATION PROCEDURE

⚠ WARNING: REMOVE ALL AIR FROM THE SYSTEM BEFORE YOU SERVICE ANY AIR SYSTEM COMPONENT. PRESSURIZED AIR CAN CAUSE SERIOUS PERSONAL INJURY. VERIFY ALL PERSONNEL ARE CLEAR OF THE TRAILER BEFORE INFLATING OR DEFLATING THE AIR SPRINGS. THE AIR SUSPENSION HAS VARIOUS PINCH POINTS THAT CAN CAUSE SERIOUS PERSONAL INJURY.

1. Release the air from the currently installed suspension and disconnect the air lines.
2. Disconnect electrical and air lines between the slider and the trailer body.
3. Remove the hold down clips.
4. Pull out the slider pin release lever on the currently installed suspension.
5. Use the appropriate lifting device to lift the trailer from the currently installed suspension.
6. Pull the currently installed suspension out from under the trailer.
7. Using the appropriate lifting device, position the new suspension with the tires installed, under the trailer.
8. Pull the slider pin release lever out to lock the pins in the retracted position.
9. Lower the trailer onto the new suspension.
10. Check that the suspension fits securely inside of the trailer body rails.
11. Pull and release the slider pin release lever.
12. Install the hold down clips. Tighten to 80 ft. lbs. (110 N•m).
13. Reconnect air and electrical connections. Pressurize the system.
14. If the slider pins do not extend through the rail holes, apply the brakes and slide the trailer until the pins align with the rail holes and extend through the rail holes.
15. Check the trailer ride height. Adjust as necessary. See ride height adjustment.
16. Align the axles, tighten pivot connection. See suspension axle.

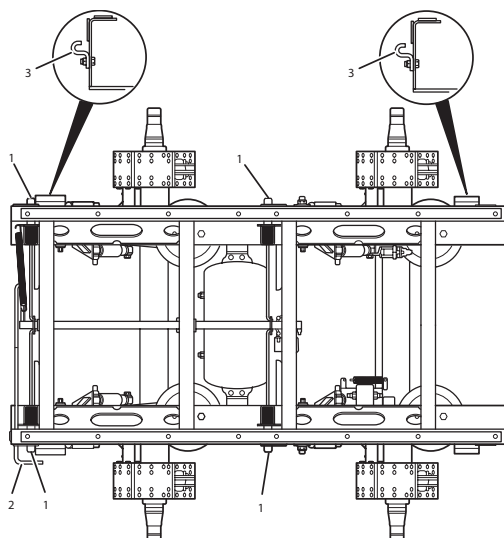

- 1 - Slider pins
- 2 - Slider pin release lever
- 3 - Slider hold down clips

DIAGNOSTICS

The following tables provide information to aid in determining the root cause of a trailer suspension system problem.

Condition	Possible Cause	Recommended Action
All air springs flat	Insufficient air pressure in reservoir to allow the PPV to supply the RH valve	Build air pressure to 75 psig (5.2 bar) or more. Check compressor for correct function. Check all air lines and fittings for leaks
	Defective pressure protection valve	Check and replace valve if necessary
	Height control valve supply or delivery	Inspect height control valve supply and fitting clogged delivery fittings for restrictions
	Air leak in system	Inspect entire system for leaks. Repair or replace as necessary
	Suspension overloaded	Review load to suspension rated capacity
Air springs fully raised but do exhaust	Height control valve delivery port of exhaust port plugged	Inspect ports for restrictions. Repair or replace as necessary
	Height Control linkage broken	Replace linkage
	Defective RH control valve	Replace RH valve
Vehicle body incorrect ride height during operation	Height control valve not adjusted properly Height control lever bent or broken	Inspect and adjust as necessary Replace lever
	Insufficient air pressure to the suspension system. (Low ride height condition)	Check air compressor and pressure protection valve for proper operation. Inspect system for leaks. Repair or replace as necessary
Main air pressure drops 65 psi	Ruptured air spring	Inspect air springs and replace as necessary (88 kPa) and lower
	Defective or inoperative PPV valve	Inspect and replace as necessary
	Leaking air lines	Inspect air lines and repair or replace as necessary
Hard Ride	Improper ride height or air springs flat	Check and adjust ride height. See first condition
	DHS engaged (DHS equipped units only)	Verify operation of DHS when parking brake is released
Suspension ride height not maintained during operation	Clogged air filters	Inspect and clean or replace as necessary
	Moisture in air tank	Drain air tank and evacuate air system of moisture
	Clogged filter screens in height control valve	Inspect and clean or replace as necessary
	Damaged linkage or incorrect valve mounting	Replace, repair, or adjust as necessary
	Defective RH control valve	Replace RH valve
Incorrect tire clearance in full jounce	Incorrect tire size	Replace tires with the recommended tire
Trailer not pulling straight (dog walk)	Trailer axles out of alignment	Realign axles
	Loose pivot bolts	Align axles, replace and tighten alignment bolts to the proper torque. Also, check hanger-wear in alignment slot - replace if found
Trailer wandering	Worn bushings	Inspect bushings per B106 Pivot Bushing Inspection Procedure and replace as needed
	Loose pivot bolts	Align axles, replace and tighten alignment bolts to the proper torque. Also, check hanger-wear in alignment slot - replace if found



Condition	Possible Cause	Recommended Action
Trailer Leans...		
Constantly in one direction	Suspension beams installed out of parallel	Determine which beam is out of parallel, replace axle and beam weldment. Contact Hendrickson technical service dept. for specific dimensions
Varies from side to side	Axle welds missing or broken (must be welded by the manufacturer)	Replace axle and beam weldment
Varies in one direction	Pivot bushing failed (rare)	Replace pivot bushing
Trailer Dog Tracks		
Constantly in one direction	Trailer frame not square, king pin excessively off center or high crown highways	Realign suspension per manuals and bias the alignment of both axles equally in opposite direction of the dog tracking
Varies from side to side	Alignment collars loose	Check alignment slot for wear. Replace pivot bolt kit and other related parts as needed. Realign the trailer
To one side under load	Suspension not square to the axle	Contact Hendrickson technical service dept. for specific dimensions
	Air springs misaligned	Compare the installation to the suspension drawing and reposition as required
	Failed pivot bushing (rare)	Replace the pivot bushing and realign per instructions
Bushing Walk		
The suspension beams have shifted from the center of the pivot bushings	Suspension beams are out of parallel (vertically or longitudinally)	Determine which beams are out of position. Contact Hendrickson technical service dept. for specific dimensions.
	Frame bracket center does not match suspension beam centers	Reposition the incorrect components and re-bush both suspension pivots. Contact Hendrickson technical service dept. for specific dimensions
	Use of improper bushing lubricant	Re-bush using only the specified lubricant (Seagull Type M, Cyclo_Lube)
Bushing can be moved vertically	Normal travel	No action is required
Bushing protrudes from the bushing tube	Faulty or worn bushing	If excessive rubber protrudes from one end, then it can indicate a bushing walk condition. Replace the bushing if this condition is present. Refer to B106 Pivot Bushing Inspection Procedure and L750 Bushing Tube Spacer Inspection / Replacement Procedure for more information
Grooving or deforming of spacer arm wear washer	Excessively dirty environment or fault worn bushing	The wear pads act as filler pieces between the hanger and the bushing tube and bushing. The pads will show signs of wear due to the movement of the suspension beam during articulation. Replace pads if worn. Refer to L750 Bushing Tube Spacer Inspection / Replacement Procedure for more information
	Wear washer life cycles are shortened	Replace as needed by widespread axle applications

TORQUE SPECIFICATIONS

⚠ WARNING: CHECK FASTENER TORQUE VALUES, TIGHTEN LOOSE FASTENERS, AND REPLACE DAMAGED FASTENERS. LOOSE, DAMAGED, OR MISSING FASTENERS CAN CAUSE LOSS OF VEHICLE CONTROL, DEATH, SERIOUS PERSONAL INJURY AND DAMAGE TO COMPONENTS.

Torque Specifications Table

Fasteners	in. lbs.	ft. lbs.	N•m
Upper air spring nut	-	40-45	54-61
Lower air spring	-	25-30	34-41
Shock absorber-upper and lower	-	210-235	285-319
Air chamber mounting nuts	-	100-115	136-156
Cam tube assembly flange bolt	-	65-85	88-115
Pivot bolt (1-1/8" dia.) Advantage	-	700-800	950-1085
Pivot bolt (7/8" dia.) SmartRide	-	500-600	678-813
Haldex Automatic Brake Adjuster control arm nut	-	8-12	11-16
Ride height valve fastener	96-144	-	11-16
Ride height valve linkage fastener	96-144	-	11-16
Slider hold down clip	-	80	110
Dock lock air bag	-	8-12	11-16
Dock lock pivot brackets	-	65-75	89-103
Dust shield mounting bolt	180-200	-	20-23

- Check fastener torque values after 1,000 miles (1,600 km) and annually thereafter
- Retighten loose fasteners
- Replace damaged fasteners to maintain correct torque values and comply with warranty requirements



APPENDIX

Typical Trailer Suspension Air System

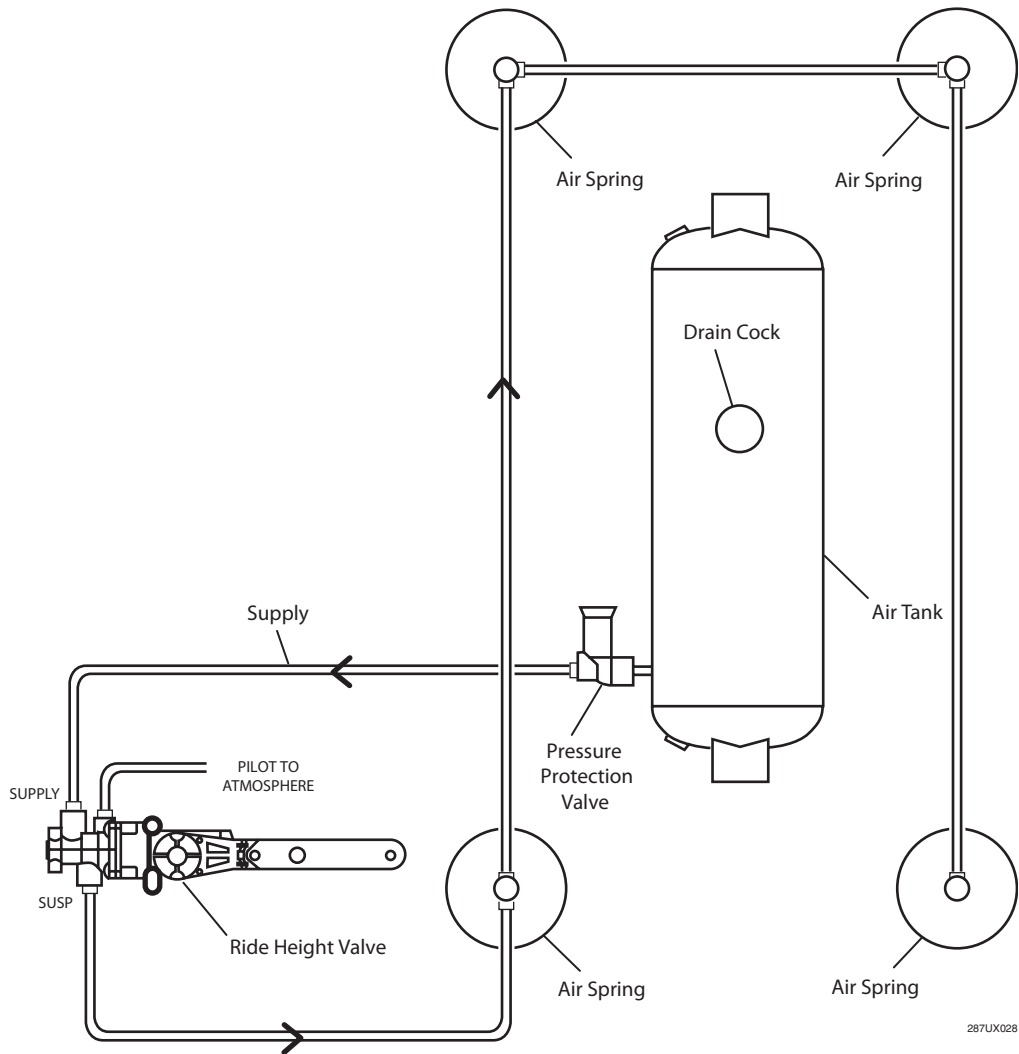

TYPICAL TRAILER SUSPENSION AIR SYSTEM WITH MANUAL DUMP VALVE

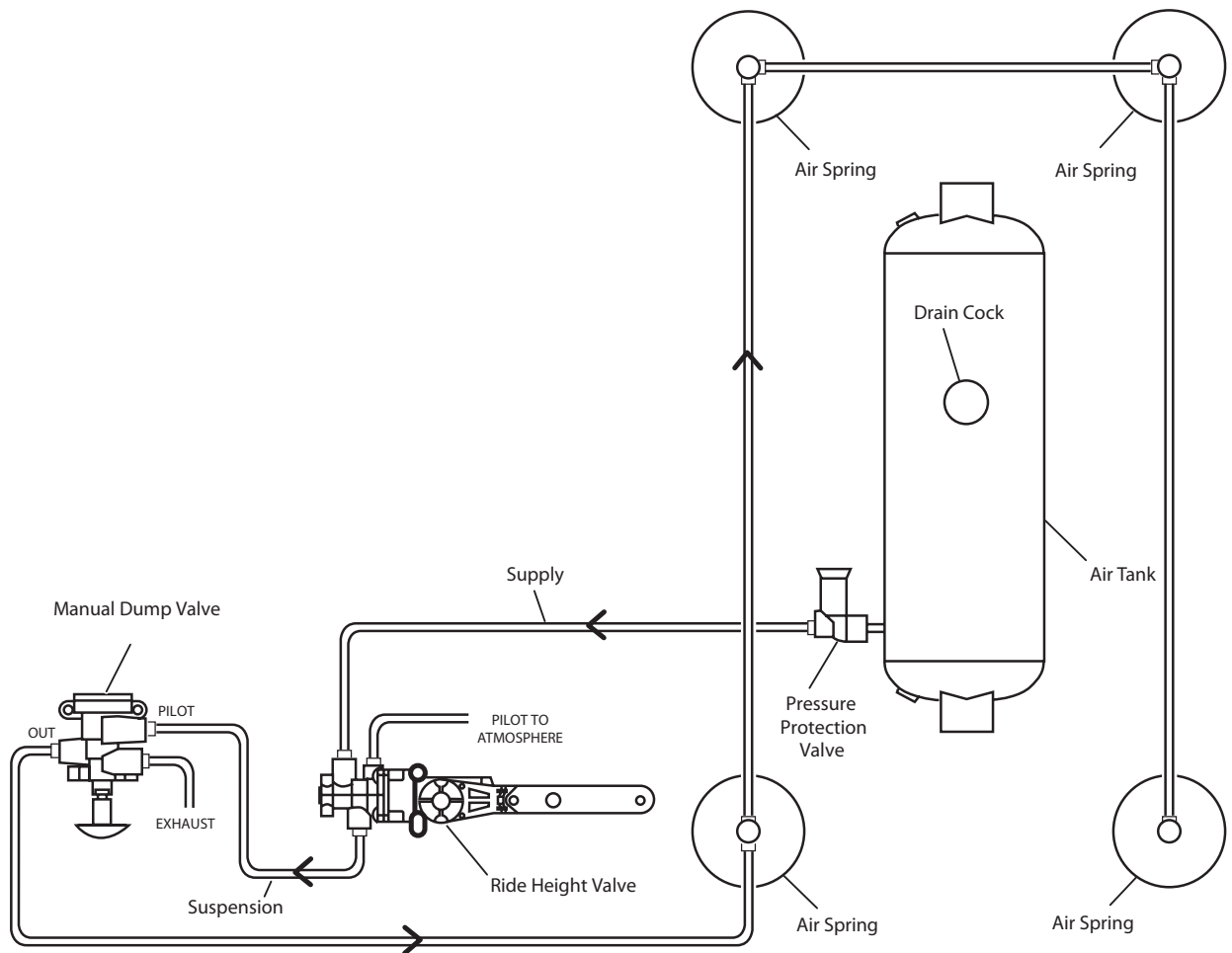

287LUX028

- Operator can manually deflate air springs allowing the trailer to rest on the air spring bumpers, or dock height support, if equipped
- Operator must manually reset the valve to inflate the air springs

⚠ Caution: Failure to inflate the trailer suspension before operating can result in damage to the suspension and / or components.



TYPICAL TRAILER SUSPENSION AIR SYSTEM WITH AUTO DUMP RIDE HEIGHT VALVE

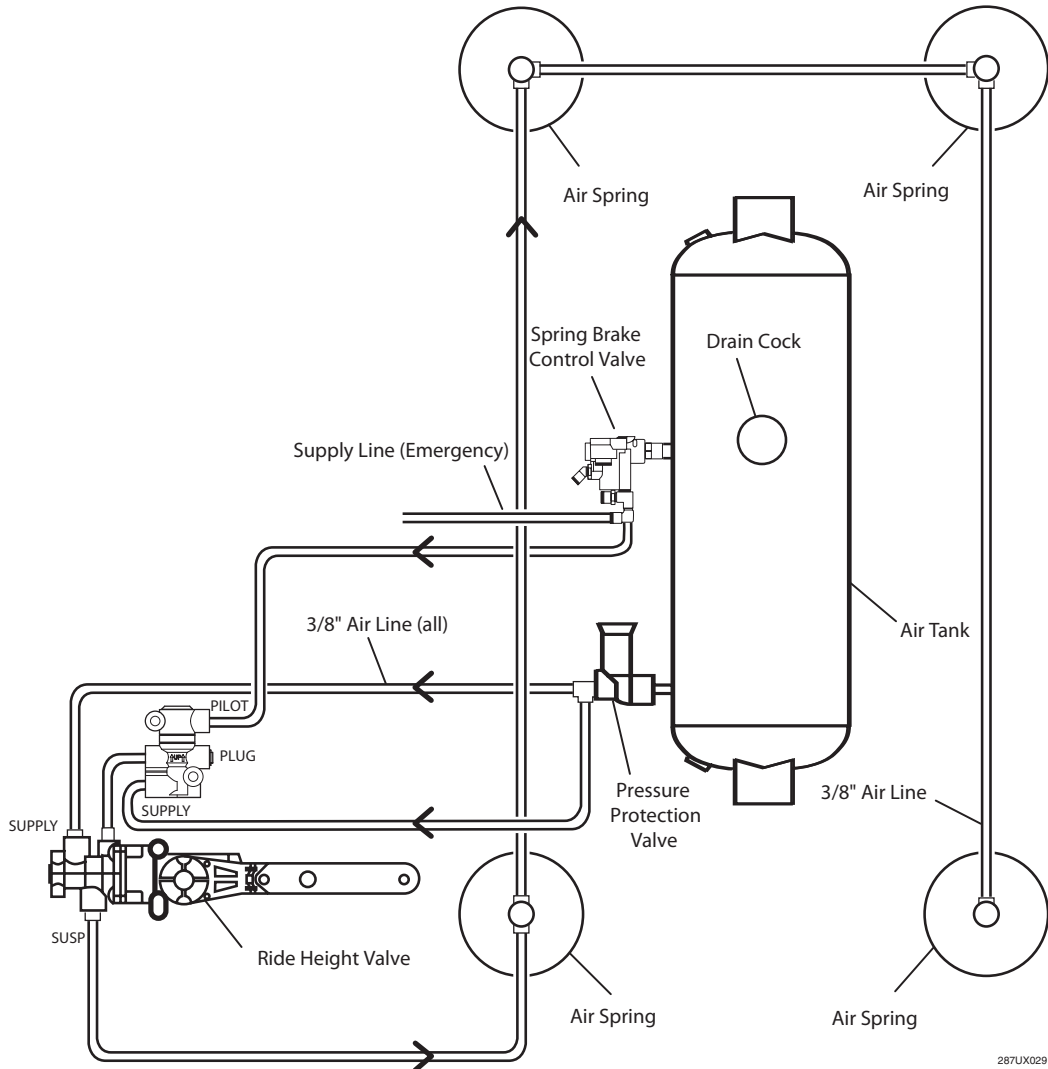

SUPPLY LINE DE-ENERGIZED

- The air springs are deflated automatically when the parking brakes are set, allowing the suspension to rest on the air spring bumpers or DHS, if equipped

NOTE: An empty or lightly loaded trailer may not rest on the air spring bumper until being loaded. Expect a sudden squat of the suspension under this condition

SUPPLY LINE ENERGIZED

- The air springs are re-inflated when the parking brakes are released

⚠ CAUTION: Failure to inflate the trailer suspension before operating can result in damage to the suspension and / or components.



TYPICAL TRAILER SUSPENSION AIR SYSTEM WITH MANUAL DUMP / AUTO RESET VALVE AND DOCK LOCK

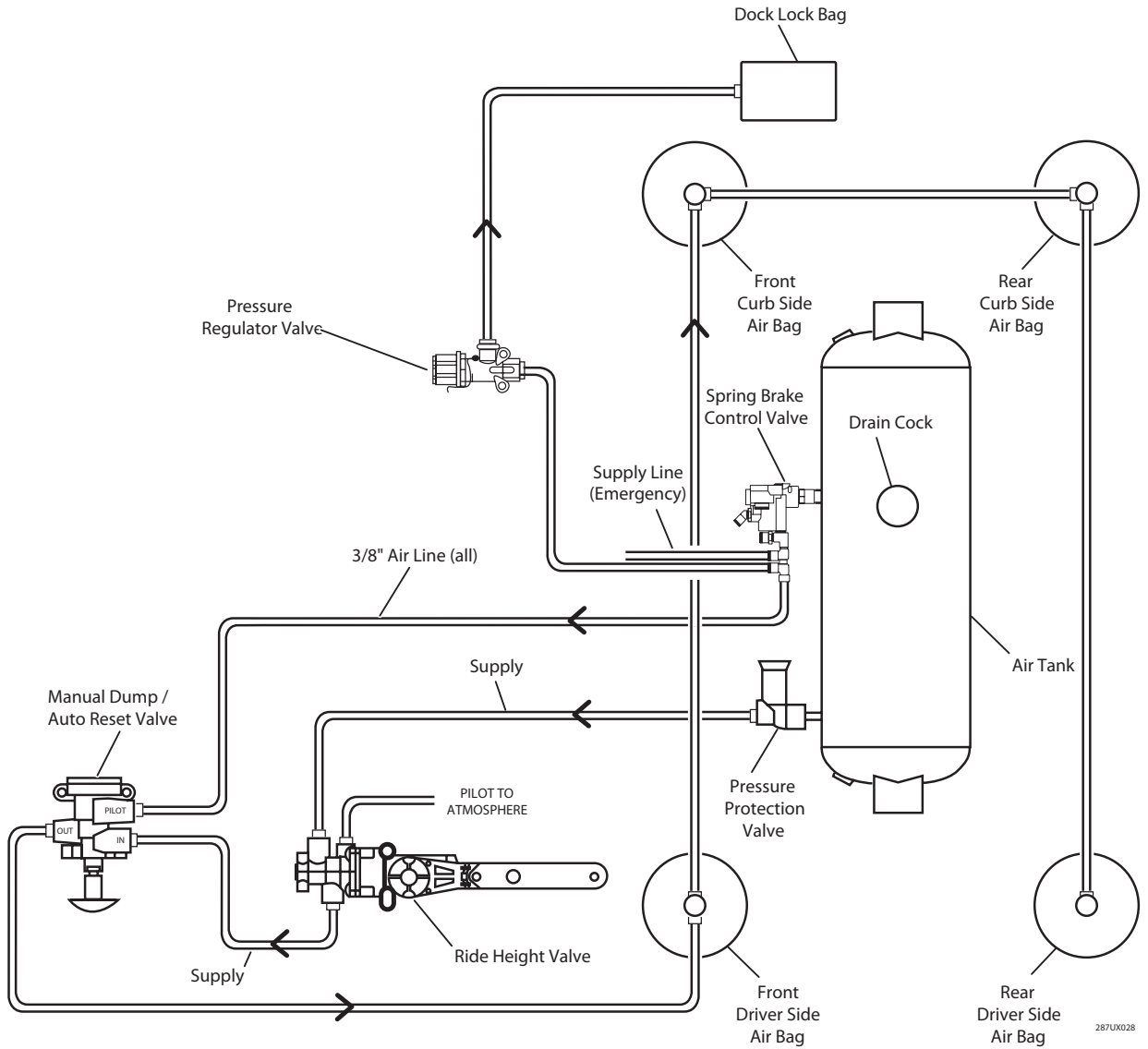

SUPPLY LINE DE-ENERGIZED

- The dock lock mechanically engages when the parking brakes are set

SUPPLY LINE ENERGIZED

- Automatically resets the manual suspension dump valve and re-inflates the suspension
- The dock lock pneumatically disengages when the parking brakes are released

PRESSURE REGULATOR

- The pressure regulator must be installed between the actuator and the supply line to limit dock lock actuator pressure to 30 PSI

⚠ CAUTION: Failure to inflate the trailer suspension before operating can result in damage to the suspension and / or components.

TYPICAL DOCK HEIGHT SUPPORT PLUMBING

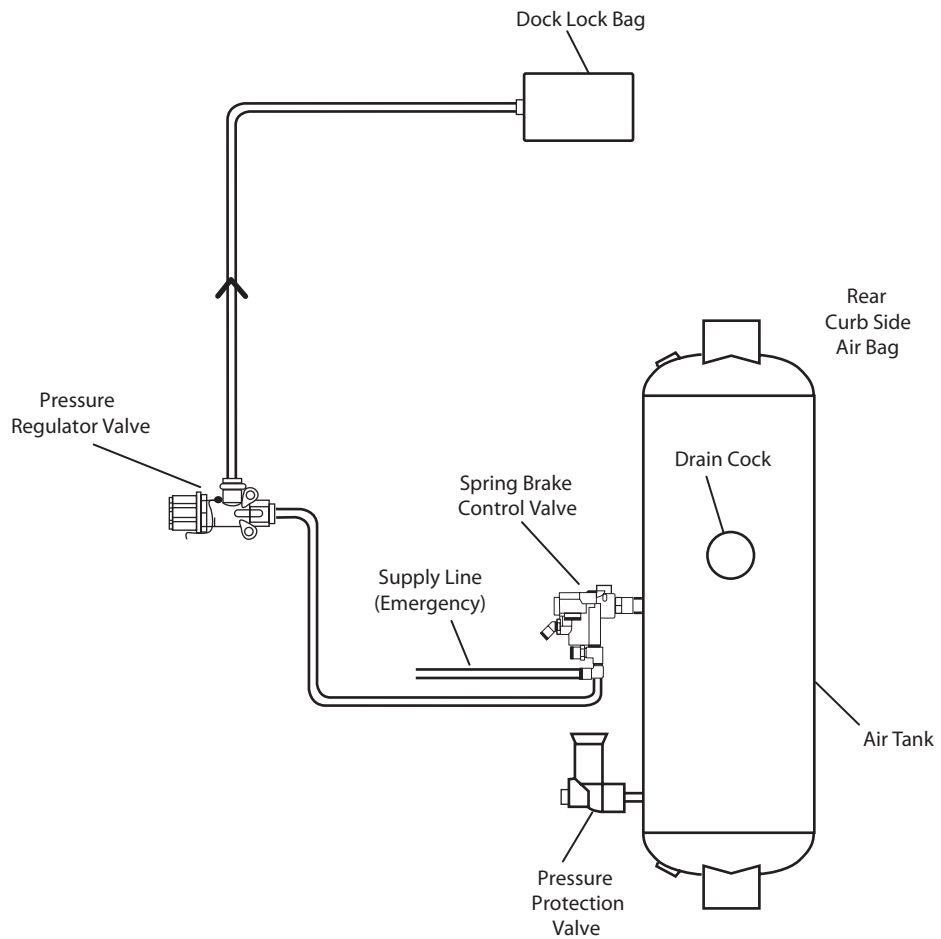

SUPPLY LINE DE-ENERGIZED

- The dock height support mechanically engages when the parking brakes are set

SUPPLY LINE ENERGIZED

- The dock height support pneumatically disengages when the parking brakes are released and the suspension is inflated

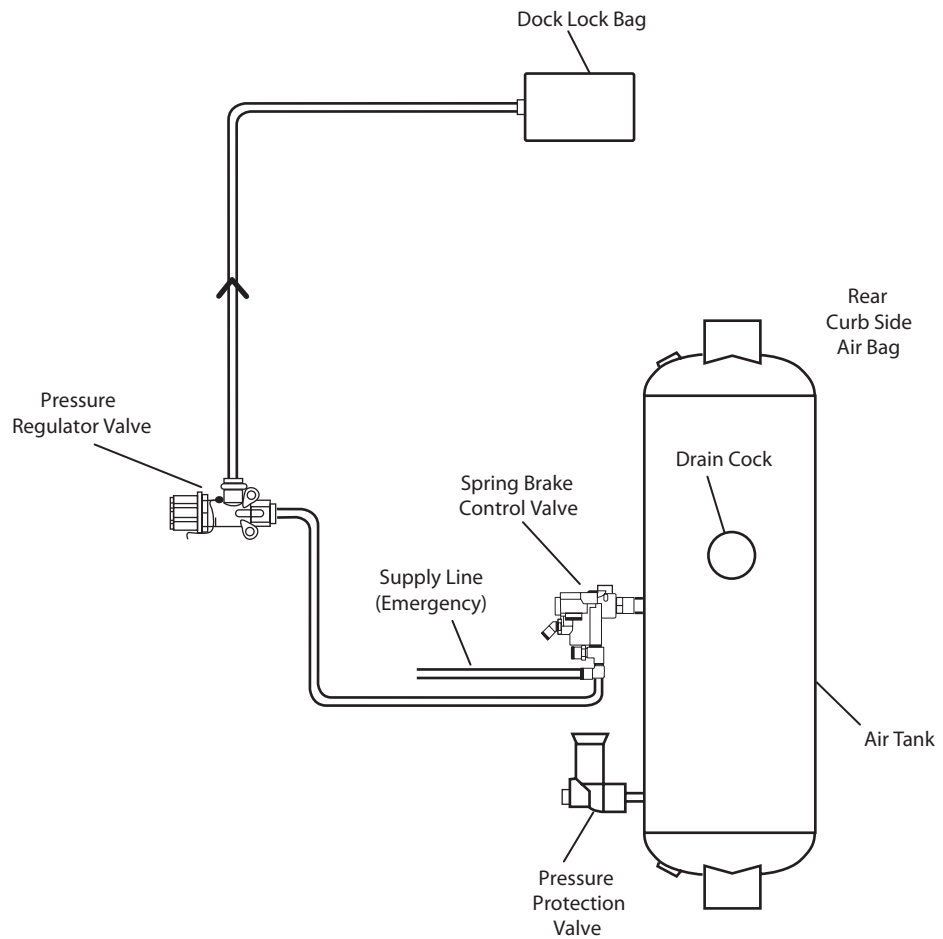
TYPICAL DOCK HEIGHT SUPPORT PLUMBING**SUPPLY LINE DE-ENERGIZED**

- The dock height support mechanically engages when the parking brakes are set

SUPPLY LINE ENERGIZED

- The dock height support pneumatically disengages when the parking brakes are released and the suspension is inflated



DHS TOFC OPERATING INSTRUCTIONS

1. With the air system fully charged, rotate the knob on the TOFC valve to the TOFC APPLICATION position (see illustration) to disengage the DHS assembly.
2. Visually check the DHS to ensure that it is disengaged (see illustration).
3. During normal or On-Highway operation, ensure that the knob on the TOFC valve has been rotated to the TRAILER SUPPLY position (see illustration) to disengage the DHS assembly.
4. Visually check the DHS to ensure that it is engaged (see illustration).

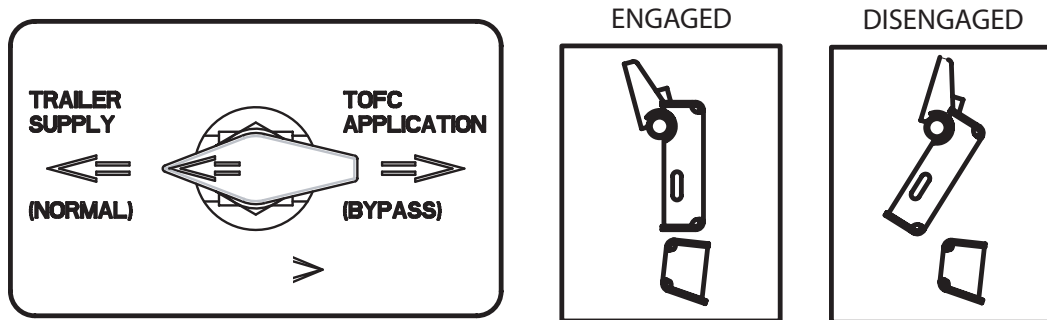

⚠ CAUTION: When transporting a trailer by TOFC you must follow the DHS disengagement procedure exactly as outlined above. Failure to perform this procedure, or performing incorrectly, may result in extensive trailer damage.

www.hendrickson-intl.com

HENDRICKSON

Trailer Suspension Systems
250 Chrysler Drive, Unit #3
Brampton, ON Canada L6S 6B6
905.789.1030
Fax 905.789.1033

Trailer Suspension Systems
2070 Industrial Place SE
Canton, OH 44707-2641 USA

866.RIDEAIR (743.3247)
330.489.0045
Fax 800.696.4416

Trailer Suspension Systems
Av. Industria Automotriz #200
Parque Industrial Sliva Aeropuerto
Apodaca, N.L., México C.P. 66600
(52) 81 8288 1300
Fax (52) 81 8288 1301