

HENDRICKSON USE ONLY

H ORDERING GUIDE

DROP AXLE

LIT NO: L1322

DATE: October 2020

Rev: B

FORM INSTRUCTIONS

For complete price and model number information on HN or HP Hendrickson Trailer Axles, fax this form to 800.696.4416 in the U.S. or 905.789.1033 in Canada.

TO:		FROM:		COMPANY NAME:	
DATE:	PHONE:	FAX:	EMAIL:		

SAME AS (OR PREVIOUS HENDRICKSON AUX AXLE P/N):	EXCEPT:
--	----------------

AXLES

AXLE STYLE:	6" Drop Style					
AXLE WALL:	<input type="checkbox"/> 0.625	<input type="checkbox"/> 0.750 (required for hump-up orientation)				
BRAKE SIZE:	<input type="checkbox"/> 12.25"	<input type="checkbox"/> 16.5" x 5"		<input type="checkbox"/> 16.5" x 7"		
SPINDLE:	<input type="checkbox"/> HN Only	<input type="checkbox"/> HN	<input type="checkbox"/> HP		<input type="checkbox"/> HN	<input type="checkbox"/> HP
BRAKE SELECTIONS:	See Chart A	See Chart B			See Chart C	

S-CAM POSITION

CAMS REAR – BRAKE ADJUSTERS DOWN

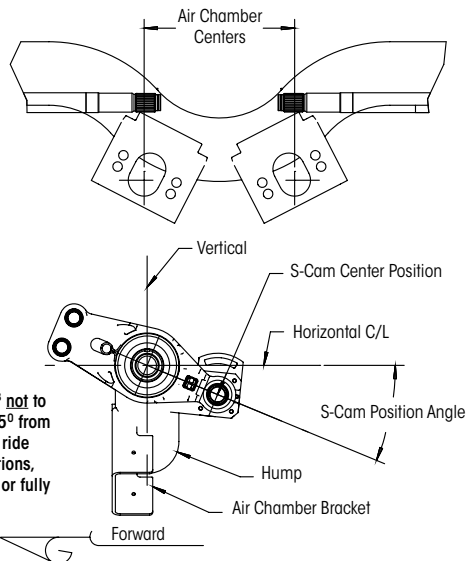

! Hump angle⁸ not to exceed +/-15° from centerline at ride height conditions, i.e. not lifted or fully extended.

CAMS FORWARD – BRAKE ADJUSTERS UP

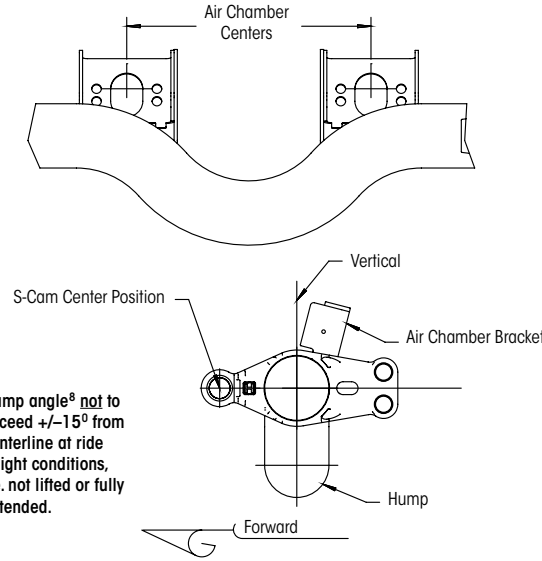

! Hump angle⁸ not to exceed +/-15° from centerline at ride height conditions, i.e. not lifted or fully extended.

NOTE: ALTERNATIVE AXLE ORIENTATION WITH HUMP UP ALLOWED. ALL HUMP-UP AXLES REQUIRE 3/4" AXLE WALL THICKNESS.

IMPORTANT! ALL ENGAGING CAMS MUST ROTATE THE SAME AS THE WHEELS IN FORWARD MOTION. CAM OPPOSITE ROTATION CAUSES COMPONENT FAILURE. HUMPS MUST BE WITHIN 15 DEGREES OF VERTICAL AS SHOWN.

H HENDRICKSON

CHART A		12.25" x 7.5" Brakes						
BRAKE LINING:	H20							
BRAKE MODEL:	HXS							
BRAKE COATING:	Standard							
AXLE TRACK:	71.50"							
S-CAM POSITION:	Cams Forward - Brake Adjusters Up							
S-CAM:	28 SPLINE							
S-CAM LENGTH:	20.75							
S-CAM ANGLE:	0 - degrees							
S-CAM ENCLOSURE:	Standard Cam Bracket							
BRAKE CHAMBER BRACKET:	Standard Chamber Bracket							
BRAKE CHAMBER:	<input type="checkbox"/> 2.5" Stroke			<input type="checkbox"/> 3.0" Stroke				
BRAKE CHAMBER SIZE:	<input type="checkbox"/> No	<input type="checkbox"/> Type 24	<input type="checkbox"/> Type 30	<input type="checkbox"/> Type 24/30	<input type="checkbox"/> Type 30/30	<input type="checkbox"/> Type 30	<input type="checkbox"/> Type 30/30	
BRAKE CHAMBER WARRANTY:		Standard		<input type="checkbox"/> Standard	<input type="checkbox"/> Extended Life	Standard	<input type="checkbox"/> Standard	<input type="checkbox"/> Extended Life
SLACK ADJUSTER LENGTH:	<input type="checkbox"/> No	<input type="checkbox"/> 5.5"		<input type="checkbox"/> 6.0" (Long Stroke Recommended)				

CHART B		16.5" x 5" Brakes						
BRAKE LINING:	H15							
BRAKE MODEL:	Standard							
BRAKE COATING:	Standard							
AXLE TRACK:	<input type="checkbox"/> 71.50"			<input type="checkbox"/> 73.50"				
S-CAM POSITION:	Cams Rear - Brake Adjusters Down			Cams Rear - Brake Adjusters Down				
S-CAM:	28 SPLINE			28 SPLINE				
S-CAM LENGTH:	22.375"			22.875"				
S-CAM ANGLE:	15-Degrees			15-Degrees				
S-CAM ENCLOSURE:	Standard Cam Bracket			Standard Cam Bracket				
BRAKE CHAMBER BRACKET:	Standard Chamber Bracket			High Rise Bracket				
BRAKE CHAMBER:	<input type="checkbox"/> 2.5" Stroke			<input type="checkbox"/> 3.0" Stroke				
BRAKE CHAMBER SIZE:	<input type="checkbox"/> No	<input type="checkbox"/> Type 24	<input type="checkbox"/> Type 30	<input type="checkbox"/> Type 30/30	<input type="checkbox"/> Type 30	<input type="checkbox"/> Type 30/30		
BRAKE CHAMBER WARRANTY:		Standard Warranty		<input type="checkbox"/> Standard	<input type="checkbox"/> Extended Life	<input type="checkbox"/> Standard	<input type="checkbox"/> Standard	<input type="checkbox"/> Extended Life
SLACK ADJUSTER LENGTH:	<input type="checkbox"/> No	<input type="checkbox"/> 5.5"	<input type="checkbox"/> 6.0" (Long Stroke Recommended)					

CHART C	16.5" x 7" Brakes							
BRAKE LINING:	<input type="checkbox"/> H20		<input type="checkbox"/> H23			<input type="checkbox"/> H26		
BRAKE MODEL:	<input type="checkbox"/> Standard <input type="checkbox"/> HXS		<input type="checkbox"/> Standard <input type="checkbox"/> HXS			<input type="checkbox"/> HXS		
BRAKE COATING:	<input type="checkbox"/> Standard							
AXLE TRACK:	<input type="checkbox"/> 71.50"				<input type="checkbox"/> 77.50"			
S-CAM POSITION:	<input type="checkbox"/> Cams Forward - Brake Adjusters Up		<input type="checkbox"/> Cams Rear - Brake Adjusters Down			<input type="checkbox"/> Cams Rear - Brake Adjusters Down		
S-CAM:	<input type="checkbox"/> 28 SPLINE		<input type="checkbox"/> 28 SPLINE			<input type="checkbox"/> 28 SPLINE		
S-CAM LENGTH:	<input type="checkbox"/> 20.625"		<input type="checkbox"/> 21.625"		<input type="checkbox"/> 22.625"		<input type="checkbox"/> 22.375"	<input type="checkbox"/> 24.625"
S-CAM ANGLE:	<input type="checkbox"/> 0 - degrees <input type="checkbox"/> 35 - degrees		<input type="checkbox"/> 15 - degrees		<input type="checkbox"/> 22.5 - degrees		<input type="checkbox"/> 0 - degrees	<input type="checkbox"/> 15 - degrees
S-CAM ENCLOSURE:	<input type="checkbox"/> Standard Cam Bracket <input type="checkbox"/> Severe Cam Tube		<input type="checkbox"/> Standard Cam Bracket		<input type="checkbox"/> Standard Cam Bracket <input type="checkbox"/> Severe Cam Tube		<input type="checkbox"/> Standard Cam Bracket	<input type="checkbox"/> Standard Cam Bracket
BRAKE CHAMBER BRACKET:	<input type="checkbox"/> Standard Chamber Bracket		<input type="checkbox"/> Standard Chamber Bracket <input type="checkbox"/> High Rise Bracket		<input type="checkbox"/> Standard Chamber Bracket		<input type="checkbox"/> Standard Chamber Bracket	<input type="checkbox"/> Standard Chamber Bracket
SLACK ADJUSTER LENGTH:	<input type="checkbox"/> No		<input type="checkbox"/> 5.5"		<input type="checkbox"/> 6.0" (Long Stroke Recommended)			
BRAKE CHAMBER¹:	<input type="checkbox"/> No		<input type="checkbox"/> 2.5" Stroke				<input type="checkbox"/> 3.0" Stroke	
BRAKE CHAMBER SIZE:	<input type="checkbox"/> No		<input type="checkbox"/> Type 24 <input type="checkbox"/> Type 30		<input type="checkbox"/> Type 30/30		<input type="checkbox"/> Type 30/30	
BRAKE CHAMBER WARRANTY:	<input type="checkbox"/> No		<input type="checkbox"/> Standard		<input type="checkbox"/> Standard <input type="checkbox"/> Extended Life		<input type="checkbox"/> Extended Life	<input type="checkbox"/> Standard <input type="checkbox"/> Extended Life

1. If brake chamber is selected, a slack adjuster length must also be selected.

DRUM BRAKE RTR® READY-TO-ROLL® PACKAGES		
	<input type="checkbox"/> Standard Service (1-Year Limited Warranty)	<input type="checkbox"/> ConMet PreSet®
HUB MATERIAL:	<input type="checkbox"/> Ductile Iron <input type="checkbox"/> Dura-Light Hub® <input type="checkbox"/> Aluminum	Aluminum
NUMBER OF STUDS:	<input type="checkbox"/> 10 <input type="checkbox"/> 8	10
BOLT CIRCLE DIAMETER:	<input type="checkbox"/> 11.25" <input type="checkbox"/> 275 mm	11.25"
WHEEL MATERIAL:	<input type="checkbox"/> Aluminum <input type="checkbox"/> Steel <input type="checkbox"/> Steel / Aluminum	<input type="checkbox"/> Aluminum <input type="checkbox"/> Steel <input type="checkbox"/> Steel / Aluminum
DUAL / SUPER SINGLE: (SS) Short Stud (LS) Long Stud	<input type="checkbox"/> Dual <input type="checkbox"/> Super Single	<input type="checkbox"/> Dual <input type="checkbox"/> Super Single
LUBE TYPE:	<input type="checkbox"/> SAE 80/90 (Standard) <input type="checkbox"/> Semi-Fluid Grease	<input type="checkbox"/> Semi-Fluid Grease <input type="checkbox"/> Synthetic 75 w/ 90
SEAL:	<input type="checkbox"/> Stemco Voyager <input type="checkbox"/> Hendrickson Standard	No (ConMet Included)
BEARING:	Standard	No (ConMet Included)
SPINDLE NUT:	Standard 3-Piece	Standard 3-Piece
HUBCAP TYPE:	Standard Bolt-On	Standard Bolt-On
ABS TONE RING:	Yes	Yes

BRAKE OPTIONS	
DUST SHIELD:	<input type="checkbox"/> No <input type="checkbox"/> Yes (16.5" Brakes Only)
ABS SENSOR:	<input type="checkbox"/> No <input type="checkbox"/> Haldex 19.7" <input type="checkbox"/> WABCO 15.7" <input type="checkbox"/> Bendix 14.84" <input type="checkbox"/> Bendix 78.7" <input type="checkbox"/> WABCO 36"

BRAKE OPTIONS	
DRUM MATERIAL:	<input type="checkbox"/> Cast <input type="checkbox"/> Fused
DRUM DUTY:	<input type="checkbox"/> Standard <input type="checkbox"/> Heavy Duty
DRUM BALANCING:	Balanced
WHEEL FASTENERS:	<input type="checkbox"/> Yes ² <input type="checkbox"/> No

1. Two (2) wheel fasteners factory installed per wheel-end with balanced packaged in plastic bag, taped and stretched-wrapped to each wheel-end.

Notes

*Actual product performance may vary depending upon vehicle configuration, operation, service and other factors.
All applications must comply with applicable Hendrickson specifications and must be approved by the respective vehicle manufacturer with the vehicle in its original, as-built configuration.
Contact Hendrickson for additional details regarding specifications, applications, capacities, and operation, service and maintenance instructions.*

Call Hendrickson at 330.489.0045 or 866.RIDEAIR (743.3247) for additional information.



www.hendrickson-intl.com

L1322 Rev B 10-20

© 2020 Hendrickson USA, L.L.C. All Rights Reserved. All trademarks shown are owned by Hendrickson USA, L.L.C., or one of its affiliates, in one or more countries.
Information contained in this literature was accurate at the time of publication. Product changes may have been made after the copyright date that are not reflected.

TRAILER COMMERCIAL VEHICLE SYSTEMS

2070 Industrial Place SE
Canton, OH 44707-2641 USA
866.RIDEAIR (743.3247)
330.489.0045 • Fax 800.696.4416

Hendrickson Canada

250 Chrysler Drive, Unit #3
Brampton, ON Canada L6S 6B6
800.668.5360
905.789.1030 • Fax 905.789.1033

Hendrickson Mexicana

Círculo El Marqués Sur #29
Parque Industrial El Marqués
Pob. El Colorado, Municipio El Marqués,
Querétaro, México C.P. 76246
+52 (442) 296.3600 • Fax +52 (442) 296.3601