

H TECHNICAL PROCEDURE

TRAILER SUSPENSION SYSTEMS QUIK-DRAW®

SUBJECT: Operation, Maintenance
and Retrofit Procedures

LIT NO: L738

DATE: January 2020

REVISION: D



Van Applications
(HK™ Series, VANTRAAX® and ULTRAA-K® models)



Platform Applications
(INTRAAX® SP models)

TABLE OF CONTENTS

Important Safety Notices	2
Conventions Applied in This Document	2
Relative Literature	3
Van Applications (HK™ SERIES, VANTRAAX® and ULTRAA-K® Models)	4
Introduction	4
Operating Instructions	4
Replacing Air Actuator	5
Replacing QUIK-DRAW® Control Valve	7
QUIK-DRAW Retrofit Installation — Van Applications (HK™ SERIES and VANTRAAX® Models) Only.....	8
Platform Applications (INTRAAX® SP Models)	11
Introduction	11
INTRAAX® SP Operating Instructions	11
Manually Operating the Locking Pins.....	13
Replacing Air Chamber Actuator	14
Replace QUIK-DRAW Control Valve	16
QUIK-DRAW Plumbing — Platform Applications (INTRAAX® SP Models) Only	16

IMPORTANT SAFETY NOTICES

Hendrickson literature number **T12007** *Technical Procedure General Safety Precautions and Information*, available at www.Hendrickson-intl.com/TrailerLit, includes important preparation, precautionary and safety information pertaining to the procedures included in this document.

To help prevent personal injury and equipment damage; warnings, cautions and other relative statements included in Hendrickson literature number **T12007** are to be read carefully and applied during the performance of the procedures included in this document.

Improper maintenance, service or repair can cause damage to the vehicle and other property, personal injury, unsafe operating conditions and potentially void the manufacturer's warranty.

CONVENTIONS APPLIED IN THIS DOCUMENT

Various techniques are used in this document to convey important information, express safety issues, provide methods for [CONTACTING HENDRICKSON](#) and how to identify and apply [HYPERLINKS](#).

EXPLANATION OF SIGNAL WORDS

Hazard signal words (such as DANGER, WARNING or CAUTION) appear in various locations throughout this publication. Information accented by one of these signal words must be observed at all times. Additional notes are utilized to emphasize areas of procedural importance and provide suggestions for ease of repair. The following definitions comply with [ANSI Z535.6](#) and indicate the use of safety signal words as they appear throughout the publication.

⚠ DANGER

Indicates a hazardous situation that, if not avoided, will result in death or serious injury.

⚠ WARNING

Indicates a hazardous situation that, if not avoided, could result in death or serious injury.

⚠ CAUTION

Indicates a hazardous situation that, if not avoided, could result in minor or moderate injury.

NOTICE

Indicates information considered important, but not hazard-related (e.g. messages relating to property damage).

IMPORTANT: An operating procedure, practice or condition that is essential to emphasize.



Safety Alert Symbol used to indicate a condition exists that, if not avoided, may result in personal injury or harm to individuals. It must be applied to DANGER, WARNING and CAUTION statements, which emphasize severity.

HYPERLINKS

Hyperlinks are identified by a dark grey line under the linked text. Internal links allow the reader to jump to a heading, step or page in this document. External links open the website or document referenced. While viewing electronically, activate the hyperlink by clicking on the underlined text.

CONTACTING HENDRICKSON

Contact Hendrickson Trailer Technical Services for technical assistance as needed. To do so, several options are available. Technical Services must be contacted before performing any warranty related service.

NOTE: DO NOT service a suspension or any component that is under warranty without first contacting Hendrickson Technical Services.

Prior to contacting Technical Services, it is best to have the following information about the vehicle and Hendrickson suspension available (all that apply):

- **Hendrickson suspension** information, (refer to [L977 Suspension and Axle Identification](#)) –
 - Suspension model number
 - Suspension serial number
 - Approximate number of suspension miles
- **Trailer information** (located on VIN plate) -
 - Type (van, reefer, flat bed, etc...)
 - Manufacturer
 - VIN (vehicle identification number)
 - In-service date¹
 - Fleet/owner name
 - Unit #

¹ If the in-service date is unknown or not available, the vehicle date of manufacture will be substituted.



- **Failure information**
 - Description of the system problem, the part number and/or the part description of the reported non-functioning part.
 - **Date of failure.**
 - Where applicable, **location of problem** on suspension / trailer (e.g., road side, front axle, rear axle, curb side rear, etc.).
- **Digital photos** of suspension and damaged areas.
- **Special application** approval documentation (if applicable).

PHONE

Contact **Hendrickson Trailer Technical Services** directly in the United States and Canada+ at **866-RIDEAIR (743-3247)**. From the menu, select:

- **Technical Services/Warranty** for technical information.
- Other selections include:
 - **Aftermarket Sales** for replacement parts information and ordering.
 - **Original Equipment Sales** for parts inquiries and ordering for trailer manufacturers.

EMAIL

HTTS@Hendrickson-intl.com

Contact Hendrickson for additional details regarding specifications, applications, capacities, and operation, service and maintenance instructions.

All applications must comply with applicable Hendrickson specifications and must be approved by the respective vehicle manufacturer with the vehicle in its original, as-built configuration.

RELATIVE LITERATURE

If you suspect your version of this or any other Hendrickson manual is not "up-to-date", the most current version is free online at:

www.Hendrickson-intl.com/TrailerLit

Available Hendrickson documentation can be viewed or downloaded from this site.

All Hendrickson online documentation is in PDF format that requires PDF reader software to open. A free application is downloadable from Adobe at <http://get.adobe.com/reader/>.

Other relative literature may include:

NAME	DESCRIPTION
L578	<i>Preventive Maintenance Guide</i>
L583	<i>Comprehensive Warranty Statement</i>
L1074	<i>Slider Suspension Information and Requirements</i>
T12007	<i>Technical Procedure General Safety Precautions and Information</i>
T39004	<i>QUIK-DRAW® Locking Pin Fastener Kit</i>

Table 1: Relative literature

Hendrickson reserves the right to make changes and improvements to its products and publications at any time. For the latest version of this manual, consult Hendrickson website

www.Hendrickson-intl.com/TrailerLit

VAN APPLICATIONS (HK™ SERIES, VANTRAAX® AND ULTRAA-K® MODELS)

INTRODUCTION

QUIK-DRAW® is a pneumatic locking pin release system designed to make slider repositioning fast and convenient. It is controlled by a single push/pull control valve, located on a control panel at the front driver's side of the slider assembly.

IMPORTANT: QUIK-DRAW is designed to operate only when the trailer parking brakes are engaged. **If the trailer parking brakes are not engaged, the QUIK-DRAW control valve will not stay in the pulled out position and the actuators will not inflate.**

NOTE: The QUIK-DRAW valve should self reset when parking brakes are released.

The QUIK-DRAW system will create up to 900 pounds of force (if required) to retract bound locking pins. If necessary, rocking of the trailer as defined in the [OPERATING INSTRUCTIONS](#) may be required to free bound locking pins.

For general safety and precautionary statements, refer to Hendrickson literature number [T12007](#), available at www.Hendrickson-intl.com/TrailerLit.

For assistance, refer to [Contacting Hendrickson on page 2](#).

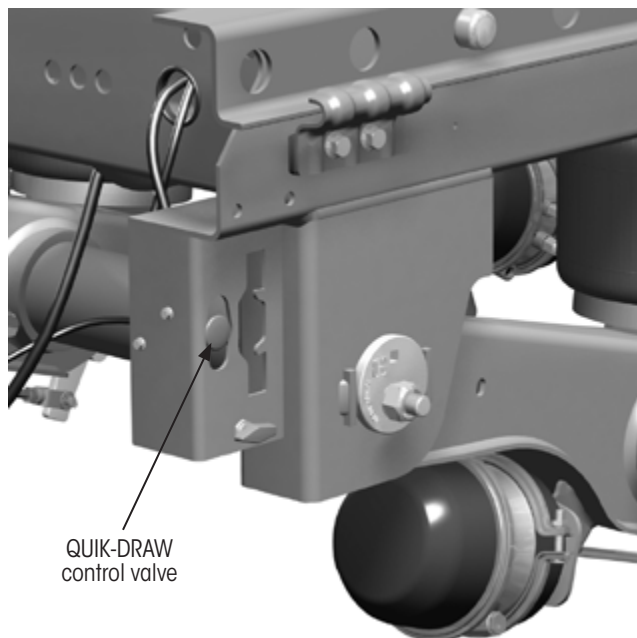

Figure 1: QUIK-DRAW control valve location

OPERATING INSTRUCTIONS

This procedure defines how to pneumatically retract the locking pins using QUIK-DRAW and trailer air supply. **DO NOT manually retract locking pins.** If QUIK-DRAW is not functioning, seek service for repairs.

1. **Clear and keep** all bystanders away from the tractor and trailer during QUIK-DRAW operation.
2. On a level surface, **apply** the trailer parking brakes.
3. **Remove** the manual stop bar (if applicable) and move it to the desired position.
4. **Pull** the QUIK-DRAW control valve knob (Figure 1) out to its fully extended position to pneumatically retract the locking pins.

NOTICE Do not force or use tools on the control valve knob.

5. **Visually ensure** each pin is fully retracted. If necessary, **gently rock trailer** forward and backward to fully retract bound locking pins.
6. **Move** trailer until slider is in desired position. **Trailer parking brakes must remain applied.**
7. **Push** QUIK-DRAW valve knob all the way in to engage locking pins. This deflates the actuators, causing the locking pin springs to force the locking pins outward into the slider box and body rail holes. When aligned, the locking pins will slip into the body rail holes, securing the slider box to the body rails.
8. **Visually ensure** each pin has extended through the slider box and body rail holes.

NOTICE Chamfered ends of locking pins must project through body rail at all four locations.

9. **Install** manual stop bar directly behind slider system.
10. **Gently rock trailer** forward and backward to completely engage misaligned locking pins.

WARNING Do not drive the trailer without pushing the QUIK-DRAW control valve in and verifying that all four locking pins have extended through the slider box and body rail holes.



REPLACING AIR ACTUATOR

Follow these procedures for replacing a QUIK-DRAW® air actuator:

NOTE: With the exception of INTRAAX® SP slider suspensions, QUIK-DRAW air actuator fasteners will no longer use the locking cotter pin (Figure 2A). It has been replaced with a custom shank length bolt-and-nut connection for production and an aftermarket Allen head shoulder bolt (Figure 2B). The aftermarket Allen head shoulder bolt is compatible with all past and current QUIK-DRAW assemblies in the field.

PREPARATION

For more details on preparing a trailer and suspension for service, refer to T12007.

1. **Apply** the trailer parking brakes and **chock** the trailer wheels.
2. **Completely depressurize** trailer air system by opening air tank drain valve.

REMOVING AIR ACTUATOR

NOTE: Leave at least one locking pin assembled as a reference for later reassembly.

1. **Disconnect** air supply line(s) from fitting(s) on end of actuator.

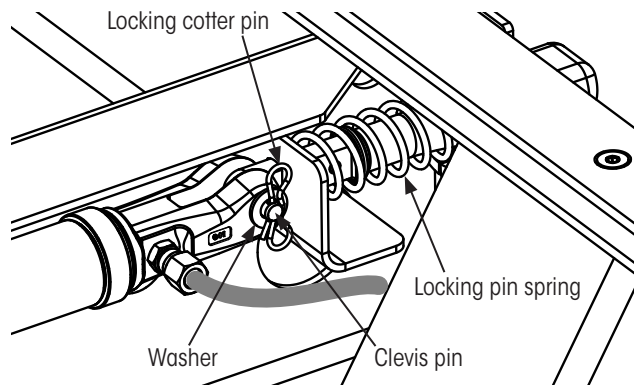

A. Clevis pin hardware

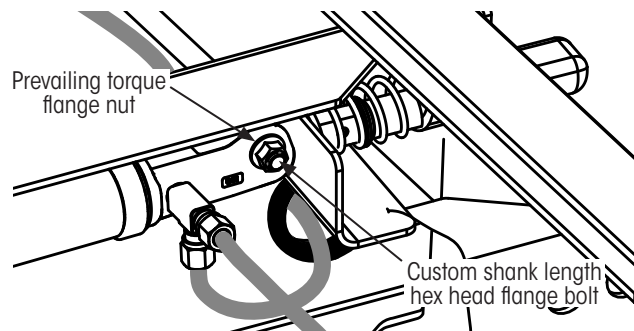

B. Bolt/nut fastener

Figure 2: Air actuator fastening hardware

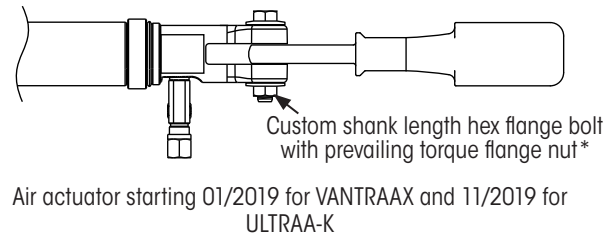
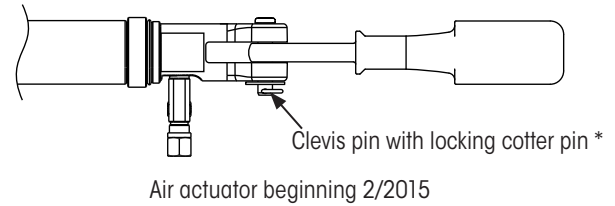
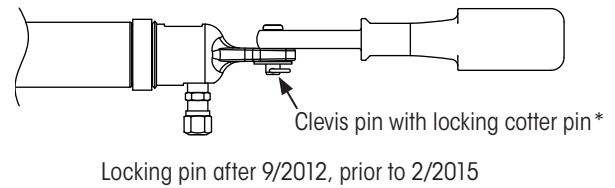
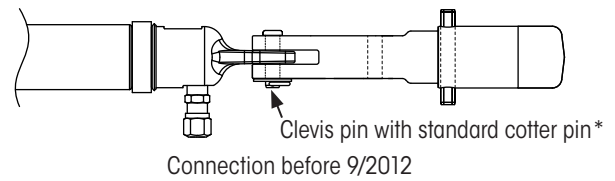

* Aftermarket fasteners will include Allen head shoulder bolts, prevailing torque nuts and flat washers.

Figure 3: Air actuator-locking pin assembly

2. **Remove** locking pin/actuator fastener (Figure 3).

NOTE: The locking pin spring (Figure 2A) should remain in place when replacing an air actuator.

3. **Push** clevis pin or bolt (Figure 2) through locking pin and air actuator end.
4. **Reach** under the frame crossmember and **pull** clevis pin or bolt completely out through access hole in frame crossmember.
5. **Repeat** Step 2 through Step 4 at other end of actuator.
6. **Remove** the actuator.



INSTALLING AIR ACTUATOR

Figure 3 shows changes that have been made to actuators and locking pins. Replacement parts and assembly may differ from the original. Refer to T39004 provided with aftermarket QUIK-DRAW service hardware kit.

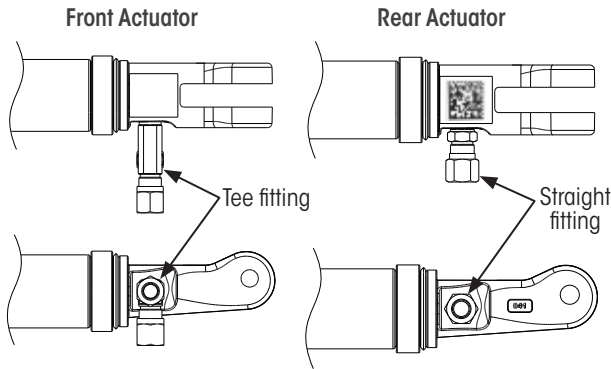

Figure 4: Actuator identification

1. **Select** the proper actuator for the location (front or rear, as shown in Figure 4).
2. The plumbing diagram, Figure 14 on page 10, shows the actuator fittings located on the same side of the slider box as the QUIK-DRAW® control valve. **Position** the actuator, with fitting, as shown in the figure.

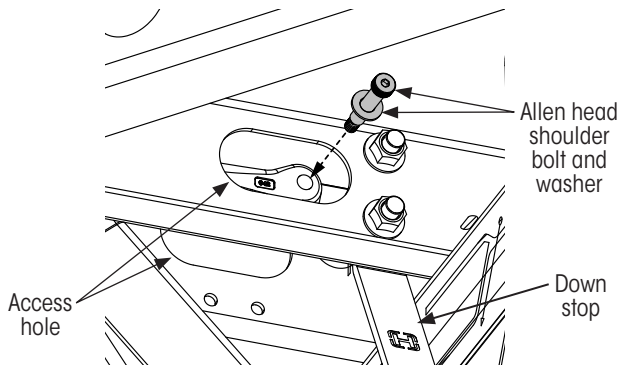

Figure 5: ULTRAA-K® front linear actuator aftermarket connection

NOTICE On ULTRAA-K sliders, the **front fasteners must be installed with the shoulder bolt through the crossmember** as shown in Figure 5 to avoid contact with the down-stop fasteners.

3. (ULTRAA-K® front linear actuator only) **Press and hold** locking pin in place to expose the original fastener through the access hole (Figure 5) during installation of the new fastener.

4. Referencing the applicable image in Figure 3, **position** each end of the actuator with the locking pin.

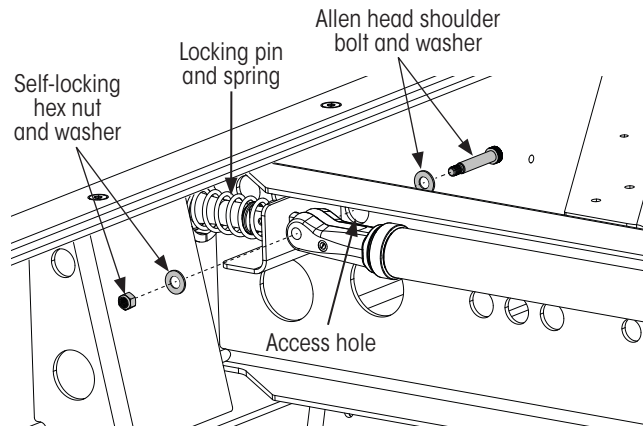

Figure 6: VANTRAAX® aftermarket actuator/locking pin assembly

5. **Align** holes (Figure 2, Figure 3, Figure 5 or Figure 6) and **insert** the fastener through the liner actuator end and locking pin at each end.
 - A. If using Allen head shoulder bolt and washers included with the aftermarket QUIK-DRAW service hardware kit (**recommended**), **install** washer and self-locking hex nut (Figure 6) on bolt at each end of the linear actuator and tighten.
 - B. If the original clevis pin is reinstalled, **install** washer and cotter pin (Figure 2A) at each end of the actuator.
 - C. If original custom shank length hex head flange bolt, **install** prevailing torque flange nut (Figure 2B) on bolt at each end of the linear actuator and tighten.

NOTE: The custom shank length hex head flange bolt threads terminate at the proper distance to prevent over tightening of the bolt.

6. **Connect** air supply line(s) to fitting on end of actuator.
7. **Repeat** above for any additional linear air actuators.
8. **Close** drain valve on trailer air tank.
9. **Fill** the air tank and trailer air system.
10. **Verify** proper QUIK-DRAW operation by **pulling** the QUIK-DRAW control valve knob (Figure 1 on page 4) out to its fully extended position.
11. **Check** air connections for leaks; **tighten** as necessary.



REPLACING QUIK-DRAW® CONTROL VALVE

Follow these procedures for replacing the QUIK-DRAW control valve for all applications:

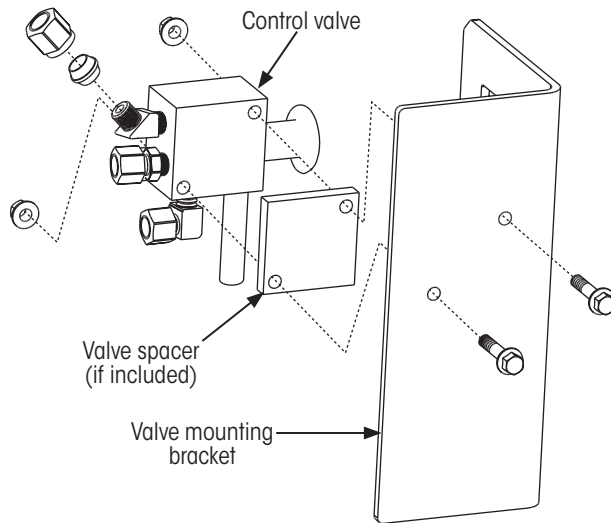

Figure 7: QUIK-DRAW control valve components

NOTE: Although the QUIK-DRAW® valve is the same for all applications, the mounting brackets and hardware (Figure 7) will vary between Hendrickson slider suspension types (HKANT, HKAT, HKAL, UTKNT, AAZ, etc.). Capturing photos of the original mounting may prove helpful when installing the replacement valve.

PREPARATION

For more details on preparing a trailer and suspension for service, refer to T12007.

1. **Apply** the trailer parking brakes and **chock** the trailer wheels.
2. **Completely depressurize** the trailer air system by opening air tank drain valve.

REMOVING CONTROL VALVE

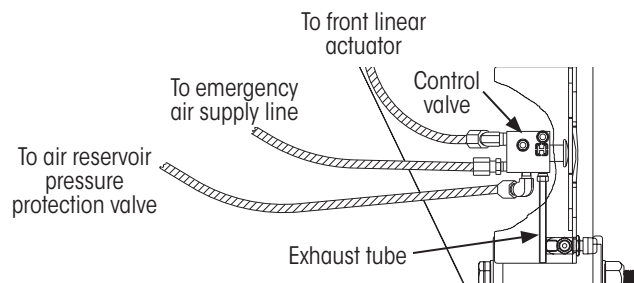

Figure 8: QUIK-DRAW valve air line connections

1. **Mark**, label or otherwise identify air lines (Figure 8, Figure 15 on page 10 or Figure 16) with corresponding fittings on QUIK-DRAW control valve before disconnecting.

2. **Disconnect** air lines from fittings on QUIK-DRAW control valve.
3. **Remove** the two control valve mounting bolts and locknuts.
4. **Remove** control valve.

INSTALLING CONTROL VALVE

NOTE: Aftermarket QUIK-DRAW valves are available with or without fittings. If without fittings and original fittings are in good condition, install the original fittings onto the valve and tighten to 11±2 ft. lbs. (15±2 Nm) of torque.

1. **Remove** any shipping plugs or hardware from the new control valve.
2. **Orient** the QUIK-DRAW control valve so the exhaust hose is facing downward and **place** the control valve, with spacer (if equipped, Figure 7), on the valve mounting bracket.
3. Using the two 1/4 - 20 x 1.5 inch hex head bolts, provided in the retrofit kit, **insert** the bolts through the QUIK-DRAW valve, spacer (if equipped) and mounting bracket holes (Figure 7).
4. **Thread** the two torque prevailing flange nuts onto the bolts.
5. **Tighten** to 11±2 ft. lbs. (15±2 Nm) of torque.
6. **Connect** air supply lines to control valve fittings as shown in Figure 8.
7. **Close** drain valve on trailer air tank.
8. **Fill** the air tank and trailer air system.
9. **Verify** proper QUIK-DRAW® operation by **pulling** the QUIK-DRAW control valve knob (Figure 1 on page 4) out to its fully extended position.
10. **Check** air connections for leaks; **tighten** as necessary.
11. **Remove** trailer wheel chocks and **release** trailer parking brakes.

NOTE: The QUIK-DRAW valve should self reset when parking brakes are released.

QUIK-DRAW RETROFIT INSTALLATION — VAN APPLICATIONS (HK™ SERIES AND VANTRAAX® MODELS) ONLY

The van application for QUIK-DRAW can be installed on any Hendrickson K-2® Slider subframe. Use the following procedure to remove the existing pin release mechanism and replace it with QUIK-DRAW:

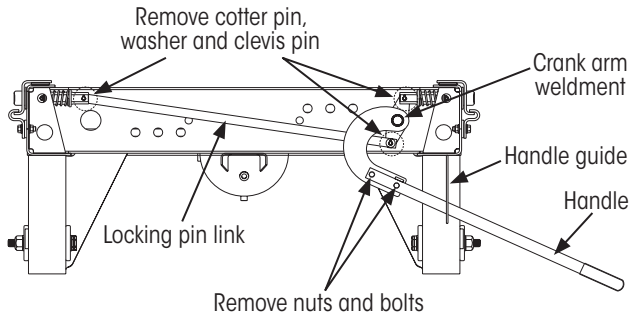

Figure 9: Removing existing pin release mechanism

Figure 9 shows a manual release mechanism. Procedures for removing other mechanical release mechanisms are similar.

PREPARATION

For more details on preparing a trailer and suspension for service, refer to T12007.

1. **Apply** the trailer parking brakes and **chock** the trailer wheels.
2. **Completely depressurize** the trailer air system by opening air tank drain valve.

REMOVING HANDLE MECHANISM AND LINKS

1. **Remove** the two handle nuts and handle bolts from the handle assembly (Figure 9).
2. **Remove** handle by pulling through handle guide.
3. **Remove** the front locking pin link (Figure 9) by removing the cotter pin, washer and clevis pin from each end of the locking pin link.
4. **Unfasten** front crank arm weldment (Figure 9) by removing cotter pin, washer and clevis pin from locking pin.
5. **Repeat** steps 3 and 4 with the rear locking pin link.

REMOVING PIPE WELDMENT

1. **Cut** the pipe weldment in half directly in front of the rear crank arm weldment (Figure 10).
2. **Remove** the long front section of pipe weldment by pulling it out from the front of the slider assembly (Figure 10).
3. **Cut** the pipe weldment in half again, this time between the rear crank arm weldment and the rear crossmember (Figure 10).
4. **Remove** the short section of pipe weldment by pulling it out from the rear of the slider assembly (Figure 10).
5. **Remove** any remaining pieces of pipe weldment.

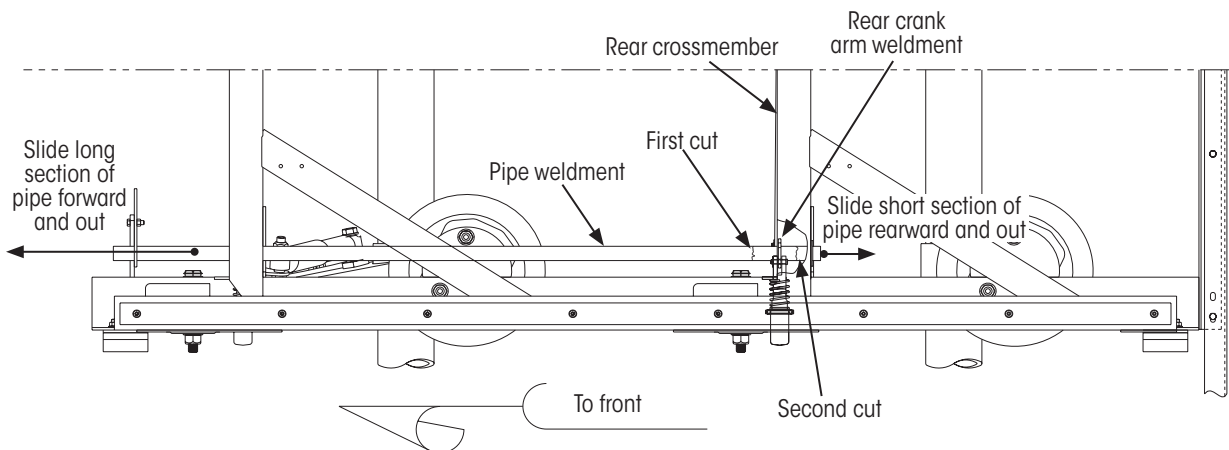

Figure 10: Removing pipe weldment



INSTALLING NEW QUIK-DRAW® VALVE

A new QUIK-DRAW control valve mounting bracket, provided with the retrofit kit, must be fastened over the existing handle guide bracket to mount the QUIK-DRAW valve.

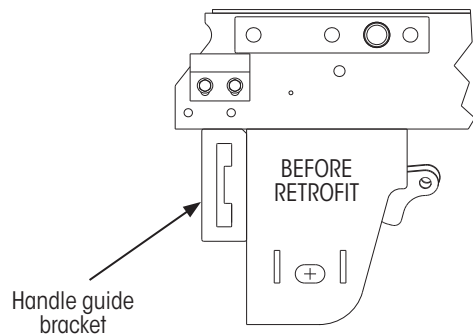

Figure 11: Existing handle guide bracket, handle removed

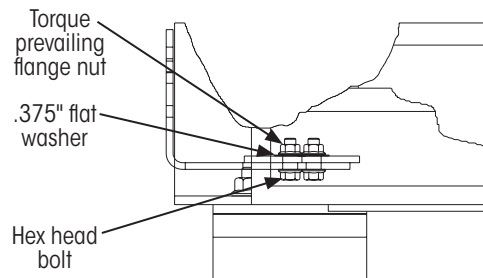
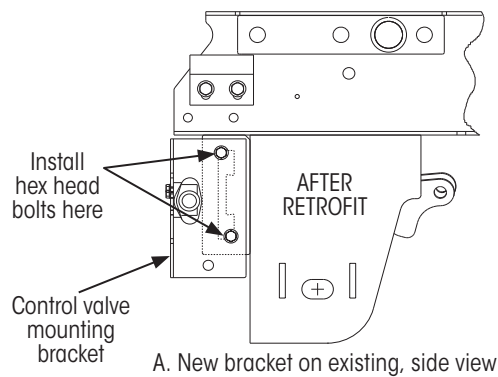

Figure 12: New QUIK-DRAW control valve mounting bracket

1. **Place** the new bracket on the existing bracket (Figure 11) as shown in Figure 12.
2. **Assemble** two hex head bolts, torque prevailing flange nuts and two of the $\frac{3}{8}$ inch washers provided in the retrofit kit.
3. **Install** the two bolt assemblies (Figure 12, B) into the handle guide cutout so the hex heads are on the outside of the bracket and the torque prevailing flange nuts and washers are on the inside.
4. **Tighten** to 30 ft. lbs. (41 Nm) of torque.

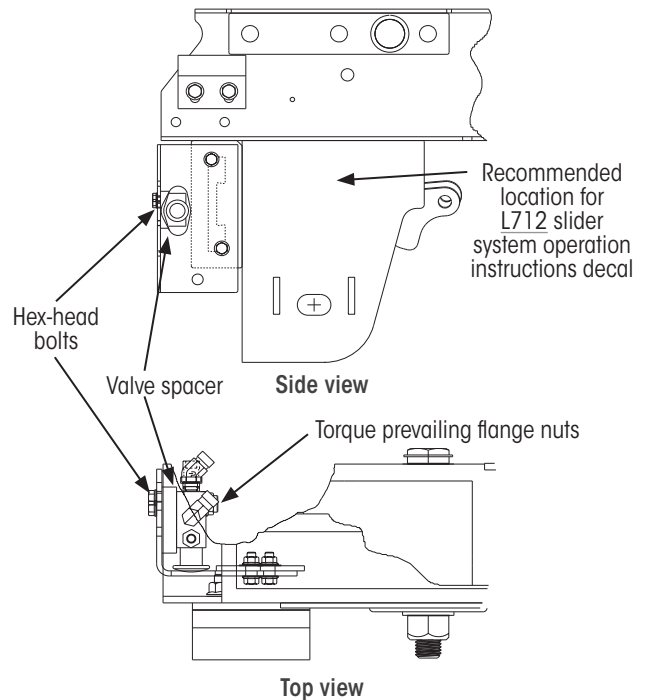

Figure 13: Installing the QUIK-DRAW® control valve

5. **Remove** any shipping plugs or hardware from the new QUIK-DRAW control valve.
6. **Orient** the QUIK-DRAW control valve so the exhaust hose is facing downward and **place** the control valve, with spacer (if equipped, Figure 13), on the valve mounting bracket.
7. Using the two $\frac{1}{4}$ - 20 x 1.5 inch hex head bolts, provided in the retrofit kit, **insert** the bolts through the QUIK-DRAW valve, spacer (if equipped) and mounting bracket holes (Figure 13).
8. **Thread** the two torque prevailing flange nuts onto the bolts.
9. **Tighten** to 11 ± 2 ft. lbs. (15 ± 2 Nm) of torque.

INSTALLING AIR ACTUATORS

1. **Install** front and rear actuators as instructed in the INSTALLING AIR ACTUATOR on page 6.
2. **Check** for proper actuator orientation (Figure 14, rear actuator has a straight fitting, front actuator has a tee fitting).
3. **Install** air lines (Figure 14), beam clip assembly, air line looms and grommets as shown in Figure 15.

NOTE: When installing the longer (rear actuator) air line, **start** at the rear actuator and work forward. This will provide the small slack loop desirable at the front actuator.

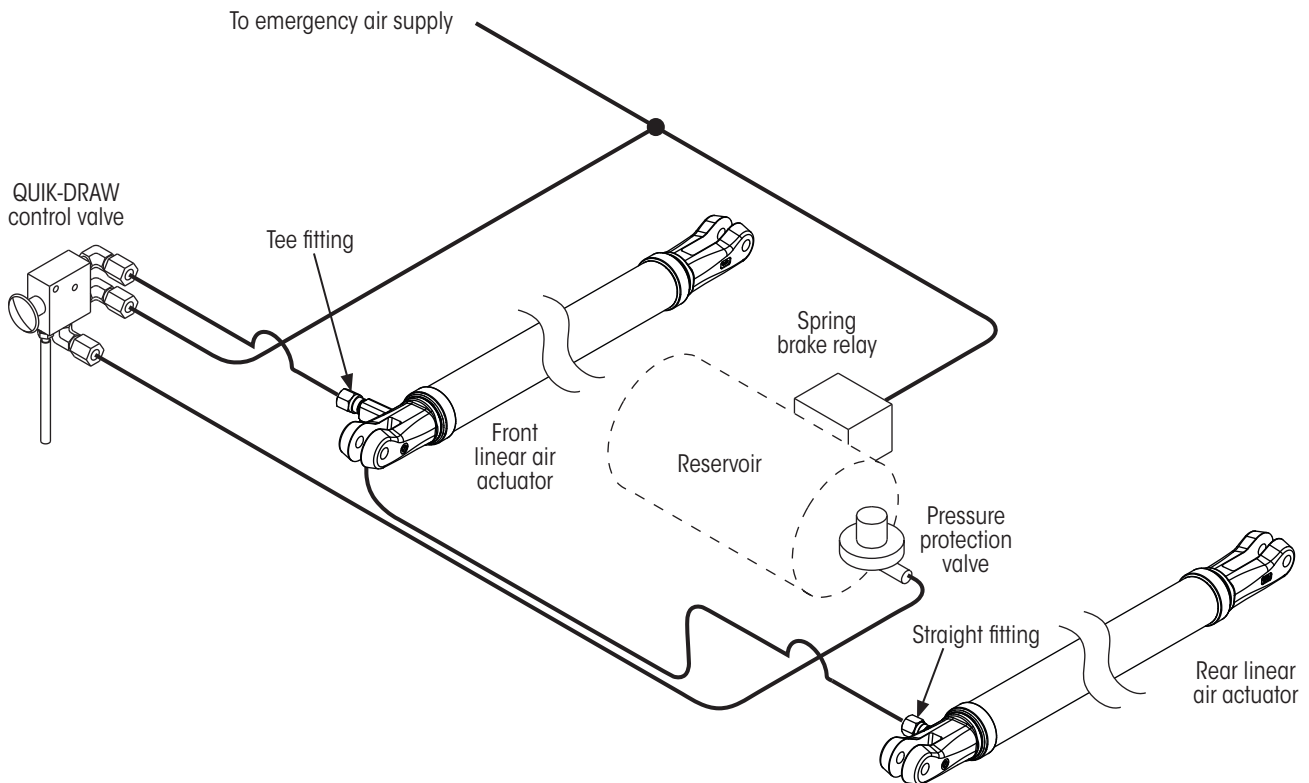

Figure 14: QUIK-DRAW plumbing diagram for van applications (HK™ Series and VANTRAAX® models)

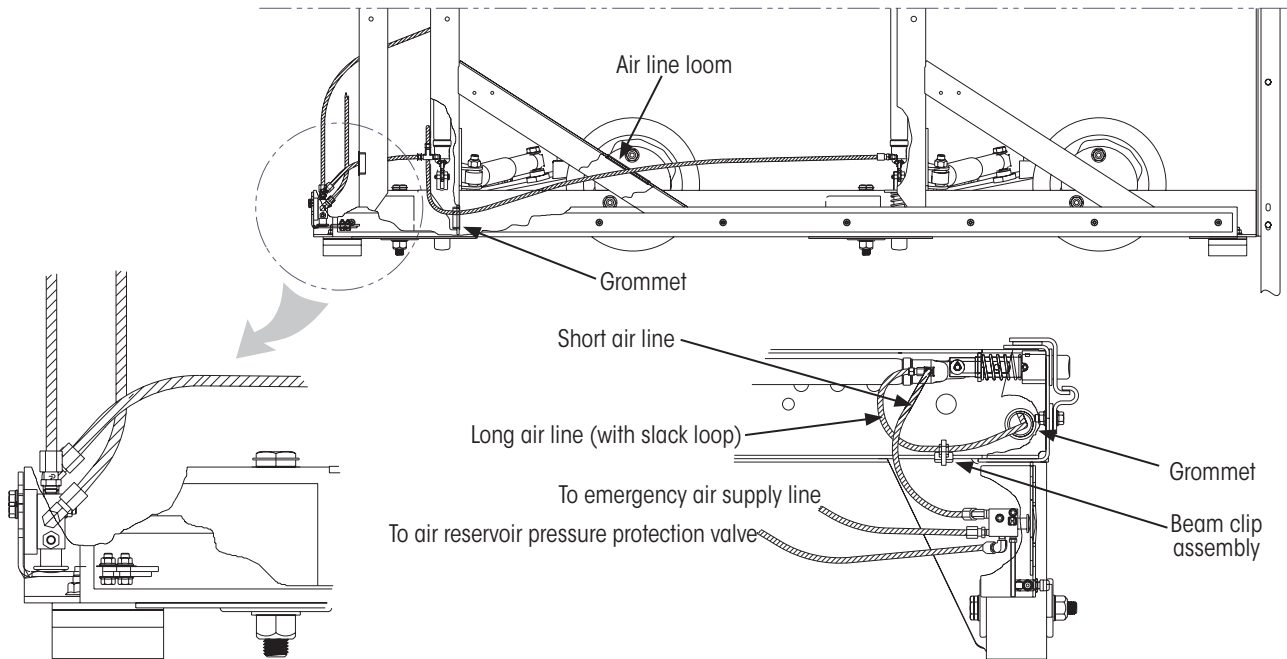

Figure 15: Air line installation details for van applications (HK™ Series and VANTRAAX® models)



VERIFYING QUIK-DRAW OPERATION

1. **Close** drain valve on trailer air tank.
2. **Fill** the air tank and trailer air system.
3. **Verify** proper QUIK-DRAW operation by **pulling** the QUIK-DRAW control valve knob (Figure 1 on page 4) out to its fully extended position.
4. **Check** air connections for leaks; **tighten** as necessary.
5. **Ensure** the air chamber actuator functions to rotate the pipe weldment, which pulls on the linkages and extracts all locking pins.
6. **Test** slider operation according to OPERATING INSTRUCTIONS on page 4. Remove wheel chocks, if necessary.
7. After final painting, **apply** the supplied *L712 Slider System Operating Instructions decal* near the QUIK-DRAW control valve (Figure 13).

PLATFORM APPLICATIONS (INTRAAX® SP MODELS)

INTRODUCTION

QUIK-DRAW® is a pneumatic locking pin release system designed to make slider repositioning fast and convenient. It is controlled by a single push/pull control valve, located on a control panel at the front driver's side of the platform slider assembly.

IMPORTANT: QUIK-DRAW is designed to operate only when the trailer parking brakes are engaged. **If the trailer parking brakes are not engaged, the QUIK-DRAW control valve will not stay in the pulled out position and the actuator will not operate.**

The QUIK-DRAW system will apply up to 400 pounds of force to all four pins simultaneously, or up to 1600 pounds of force to a single pin (if required) to retract bound locking pins. If necessary, rocking of the trailer as defined in the INTRAAX® SP OPERATING INSTRUCTIONS may be required to free bound locking pins.

INTRAAX® SP OPERATING INSTRUCTIONS

Operating procedures are included for INTRAAX SP (AAZ) single axle slider suspension, as well as tandem and tridem axle slider suspensions.

INTRAAX SP SINGLE AXLE SLIDER SUSPENSIONS

This procedure is for a Hendrickson INTRAAX SP single axle slider with Hendrickson's recommended AKSS0001 plumbing kit. This kit allows for brakes being applied and air springs exhausted while sliding.

1. **Clear and keep** all bystanders away from the tractor and trailer during QUIK-DRAW® operation.
2. On a level surface, **apply** the trailer parking brakes.

At Trailer

3. **Proceed** to the trailer axle that will be repositioned.
4. **Remove** the optional manual stop bar (if installed):
 - A. **If repositioning the slider forward, place** the stop bar in the body rails just in front of the desired slider location.
 - B. **If repositioning the slider rearward, place** the stop bar just behind the desired slider location.

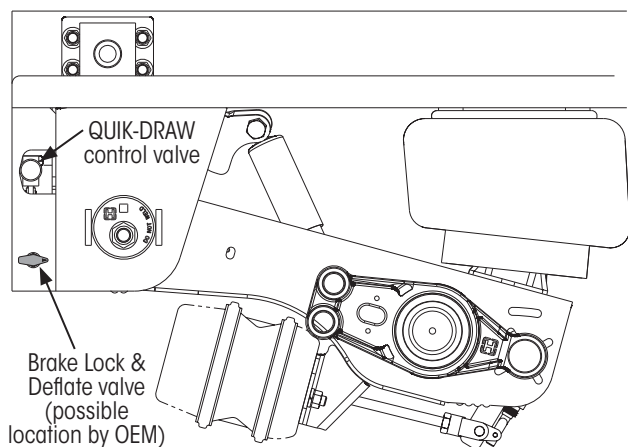

Figure 16: QUIK-DRAW control valve location

5. Pull the QUIK-DRAW control valve knob (Figure 16) out to its fully extended position. This pneumatically retracts the locking pins.

NOTICE Do not force or use tools on the knob.

6. Turn the Brake Lock & Deflate valve (Figure 16, included with kit AKSS0001) to the DUMP position.
 - A. Air should exhaust from the axle air springs.
 - B. Brakes on the axle are applied and isolated from the rest of the braking system. This prevents the brakes from being released in the next step.

At Tractor

7. Release the trailer parking brakes. This releases the brakes on all trailer axles except the axle being repositioned, allowing the tractor/trailer to be moved independently of the isolated axle.
8. Slowly move the trailer forward or backward while the isolated axle remains stationary, allowing it to be repositioned on the trailer.

NOTE: It may be necessary to gently rock trailer forward and backward to fully retract misaligned locking pins.

9. Apply trailer parking brakes.

At Trailer

10. Check the position of the slider and ensure locking pins are aligned with the desired positioning holes in the web of the trailer I-beams.
11. Repeat Step 7 through Step 10, if necessary.

12. When locking pins are aligned with the holes in the web of the trailer I-beams, push the QUIK-DRAW control valve knob all the way in.
13. Ensure each pin has extended through the positioning holes in the web of the trailer I-beams.

NOTICE Chamfered ends of all four locking pins must extend through the I-beams). If necessary, repeat Step 7 through Step 10 to gently move the trailer so misaligned locking pins can fully extend.

WARNING Do not drive the trailer without verifying that all four locking pins have extended through the positioning holes in the web of the trailer I-beams.

14. Turn the Brake Lock & Deflate valve to the NORMAL position.
 - A. The axle air springs re-inflate.
 - B. Brakes on the isolated axle are reintegrated with the rest of the braking system, allowing them to be released in the next step.

At Tractor

CAUTION DO NOT operate the trailer without reinflating the suspension and releasing the trailer parking brakes.

15. Release the trailer parking brakes.

IMPORTANT: Testing to ensure brakes are properly applied to all axles on the trailer is highly recommended after sliding.

16. Move the tractor/trailer forward or backward and ensure the repositioned axle moves with the tractor/trailer.
17. Apply the vehicle service brakes and ensure the repositioned axle stops with the tractor/trailer.

TANDEM AND TRIDEM AXLE SLIDER SUSPENSIONS

1. Clear and keep all bystanders away from the tractor and trailer during QUIK-DRAW® operation.
2. On a level surface, apply the trailer parking brakes and chock trailer wheels.
3. Remove the optional manual stop bar (if installed):

- A. **If repositioning the slider forward, place** the stop bar in the body rails just in front of the desired slider location.
 - B. **If repositioning the slider rearward, place** the stop bar just behind the desired slider location.
4. **Pull** the QUIK-DRAW control valve knob (Figure 16) out to its fully extended position. This pneumatically retracts the locking pins.

NOTICE Do not force or use tools on the knob.

5. **Ensure** each pin is fully retracted. If necessary, **gently rock trailer** forward and backward to fully retract misaligned locking pins.
6. **Reposition** the slider by slowly moving the trailer forward or backward to the desired position.
7. **Push** the QUIK-DRAW control valve knob all the way in. This causes the locking pin springs to force the locking pins outward into the positioning holes in the web of the trailer I-beams. When aligned, the locking pins will slip into the positioning holes, securing the platform slider to the trailer I-beams.
8. **Ensure** each pin has extended through the positioning holes in the web of the trailer I-beams.

NOTICE Chamfered ends of all four locking pins must extend through the I-beams). If necessary, **gently rock trailer** forward and backward to completely engage misaligned locking pins.

WARNING **DO NOT** drive the trailer without pushing the QUIK-DRAW control valve **knob** in and verifying that all four locking pins have extended through the positioning holes in the web of the trailer I-beams.

MANUALLY OPERATING THE LOCKING PINS

Just as QUIK-DRAW uses an air actuator to retract locking pins, it uses coil springs to extend them. These coil springs (Figure 18) apply a constant outward force on the locking pins, causing them to stay fully extended and in position through the positioning holes in the web of the trailer I-beams. The coil springs force the locking pins to remain engaged, even if an air actuator malfunction occurs.

In the unlikely event of a QUIK-DRAW system malfunction, the locking pins can still be manually operated. To manually operate the locking pins, use the following procedure:

1. Begin with slider operation as described in the INTRAAX SP SINGLE AXLE SLIDER SUSPENSIONS or TANDEM AND TRIDEM AXLE SLIDER SUSPENSIONS, but stop when the “**pull** the QUIK-DRAW control valve knob out” step is reached.
2. **Look** under the trailer at the front of the platform slider frame and **locate** the hexagonal bolt head on the end of the pipe weldment (Figure 17).

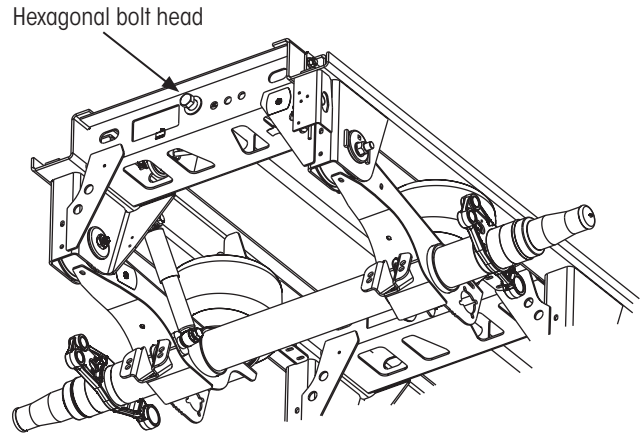

Figure 17: Hexagonal bolt head location

3. Using a 1 1/2 inch wrench on the hexagonal bolt head, **rotate and hold** the pipe weldment counterclockwise approximately 1/8 turn, or until the hole in a locking pin (Figure 18) is visible on the inboard side of the locking pin cage assembly. If the locking pins are free to move, it will require approximately 60 ft. lbs. (81 Nm) of torque to rotate the pipe weldment.
4. **Insert** a Phillips head screwdriver or 1/4 x 3 inch bolt in the exposed hole in one of the retracted locking pins (Figure 18). This will hold all of the locking pins in the retracted position because they are all interconnected by the locking pin linkages and pipe weldment.

NOTE: Only one locking pin needs to be held extracted for this procedure.

5. **Continue** with slider operation as described in the INTRAAX SP SINGLE AXLE SLIDER SUSPENSIONS or TANDEM AND TRIDEM AXLE SLIDER SUSPENSIONS sections, but stop when the “**push** the QUIK-DRAW® control valve in” step is reached. Instead of pneumatically extending the locking pins, use the following step to manually extend them.
6. **Carefully Remove** the screwdriver or other device used to retract the locking pins. Keep clear of all moving parts.

NOTE: If necessary, repeat Step 3 to relieve tension on the locking pin while removing the screwdriver.

7. **Finish** slider operation as described in the INTRAAX SP SINGLE AXLE SLIDER SUSPENSIONS or TANDEM AND TRIDEM AXLE SLIDER SUSPENSIONS sections.

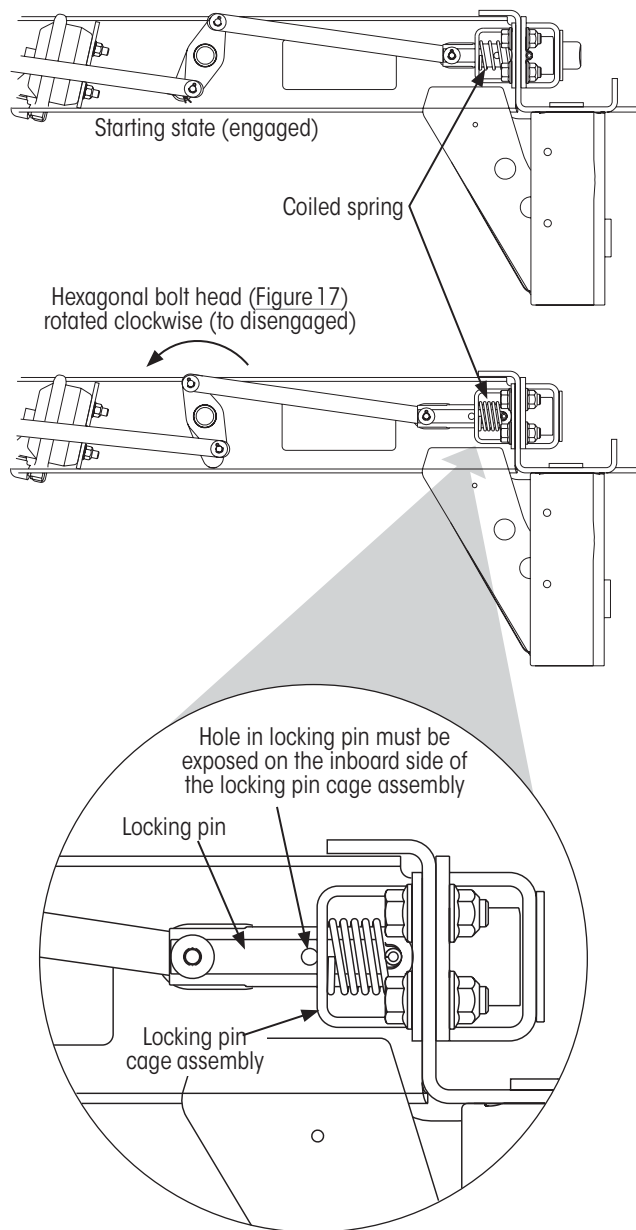

Figure 18: Manually operating the locking pins

REPLACING AIR CHAMBER ACTUATOR

PREPARATION

For more details on preparing a trailer and suspension for service, refer to T12007.

1. **Apply** the trailer parking brakes and **chock** the trailer wheels.
2. **Completely depressurize** the trailer air system by opening air tank drain valve.

REMOVING AIR CHAMBER ACTUATOR

To remove the QUIK-DRAW air chamber actuator:

1. **Disconnect** the air supply line from the fitting on the bottom of the actuator (Figure 19).
2. **Remove** cotter pin and washer from clevis pin attaching curbside front locking pin to actuator linkage.
3. **Push** clevis pin through holes in locking pin and actuator link.
4. **Reach** under frame crossmember and **pull** clevis pin completely out through access hole in frame crossmember.
5. **Remove** cotter pin and clevis pin attaching actuator yoke to crank arm on actuator linkage (Figure 19).
6. Using an $\frac{11}{16}$ inch wrench, **remove** the two nuts attaching the actuator to the mounting bracket inside the frame crossmember.
7. **Remove** actuator through opening in top of frame crossmember.

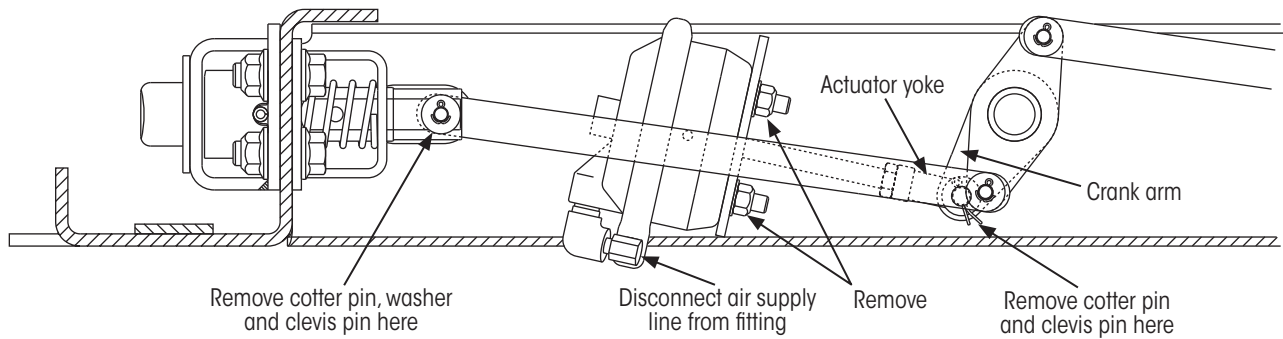

Figure 19: Actuator removal details

INSTALLING AIR CHAMBER ACTUATOR

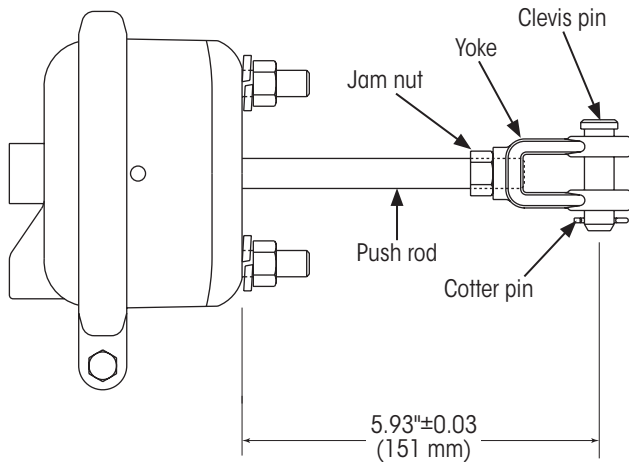

Figure 20: Verifying actuator free length

1. **Inspect** the new actuator to **ensure** the distance from the center of the clevis pin to the mounting surface of the actuator is 5.93 ± 0.03 inches (Figure 20). **If not:**
 - A. **Loosen** the jam nut attaching the yoke to the push rod of the actuator.
 - B. **Adjust** yoke to the proper length.
 - C. **Tighten** the jam nut to 25 ± 5 ft. lbs. (34 ± 6 Nm) of torque.
 2. **Remove** the air fitting from old actuator and **install** into new one. Connection must be air tight.
- NOTE:** The connection should be checked during testing and tightened as needed.
3. **Remove** the cotter pin and clevis pin from the yoke on the push rod of the new actuator.
 4. **Remove** the $\frac{11}{16}$ inch nuts from the threaded studs on the actuator.

5. **Install** the actuator through the opening in the top of the front frame crossmember, and onto the mounting bracket inside the crossmember. The threaded studs on the mounting surface of the actuator must pass through the holes in the mounting bracket. The crank arm on the actuator linkage (Figure 19) must fit between the tangs of the actuator yoke, and the holes in the yoke must line up with the hole in the crank arm.
6. **Reinstall** the clevis pin in the actuator yoke, ensuring it passes through the hole in the crank arm.
7. **Reinstall** the cotter pin to secure the clevis pin.
8. **Reinstall** the $\frac{11}{16}$ inch nuts onto the threaded studs of the actuator, and **tighten** to 35 ± 3 ft. lbs. (48 ± 3 Nm) of torque.
9. **Swing** the previously-disconnected actuator link upward, until the clevis pin hole lines up with the holes in the curbside locking pin (Figure 19). The end of the actuator link must fit into the slot in the locking pin.
10. **Reinstall** the clevis pin, washer, and cotter pin previously **removed**.
11. **Connect** air supply line to fitting on bottom of actuator.
12. **Close** drain valve on trailer air tank.
13. **Fill** the air tank and trailer air system.
14. **Verify** proper QUIK-DRAW[®] operation by **pulling** the QUIK-DRAW control valve knob (Figure 1 on page 4) out to its fully extended position.
15. **Check** air connections for leaks and **tighten** as necessary.



REPLACE QUIK-DRAW CONTROL VALVE

Refer to Figure 21 and Figure 22 for information relative to INTRAAX® SP slider plumbing. For procedures to replace the QUIK-DRAW control valve, go to REPLACING QUIK-DRAW® CONTROL VALVE on page 7:

QUIK-DRAW PLUMBING — PLATFORM APPLICATIONS (INTRAAX® SP MODELS) ONLY

Install air lines and beam clip assemblies with reference to Figure 21 and Figure 22.

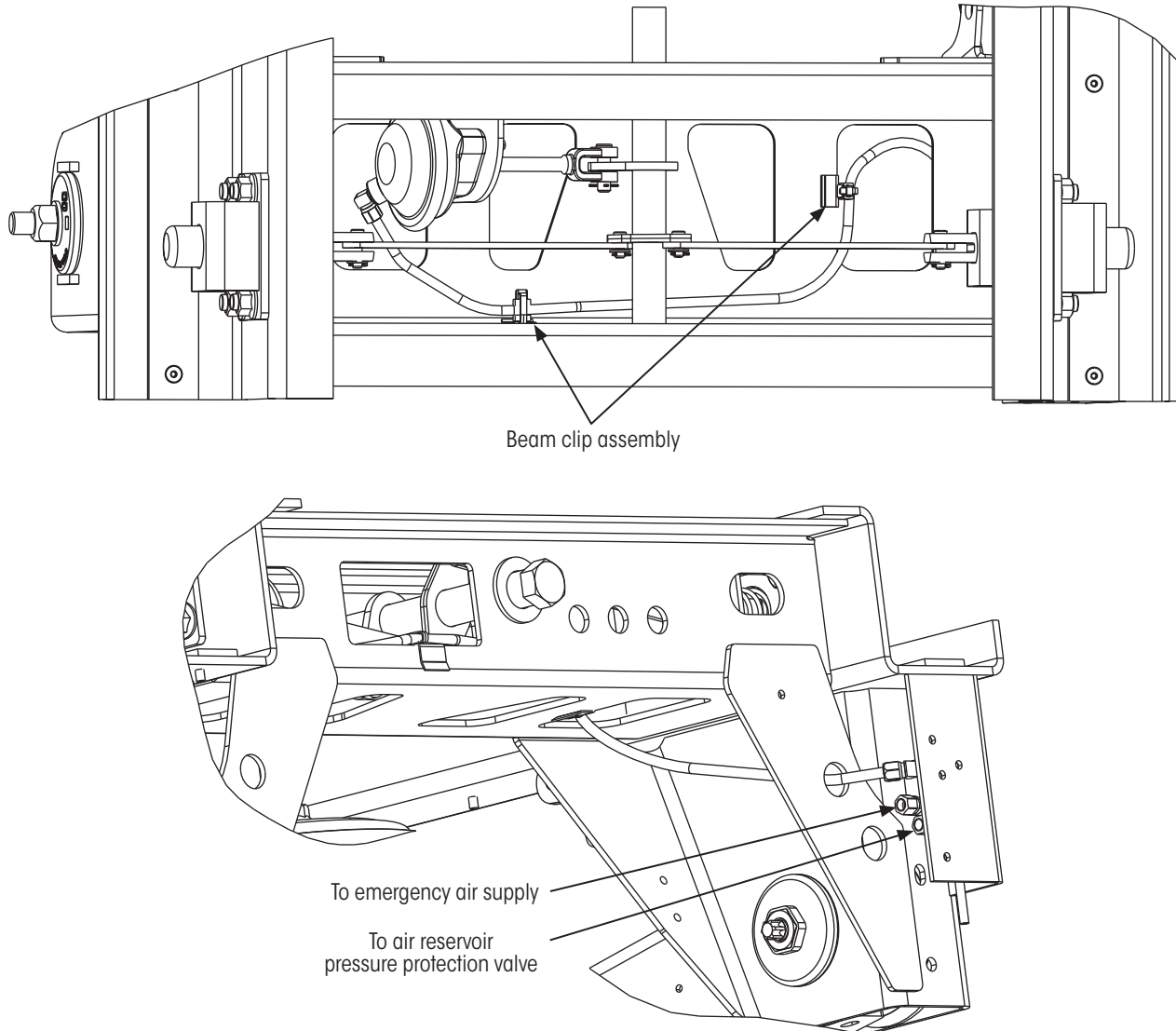

Figure 21: Air line installation details for platform applications (INTRAAX SP models)

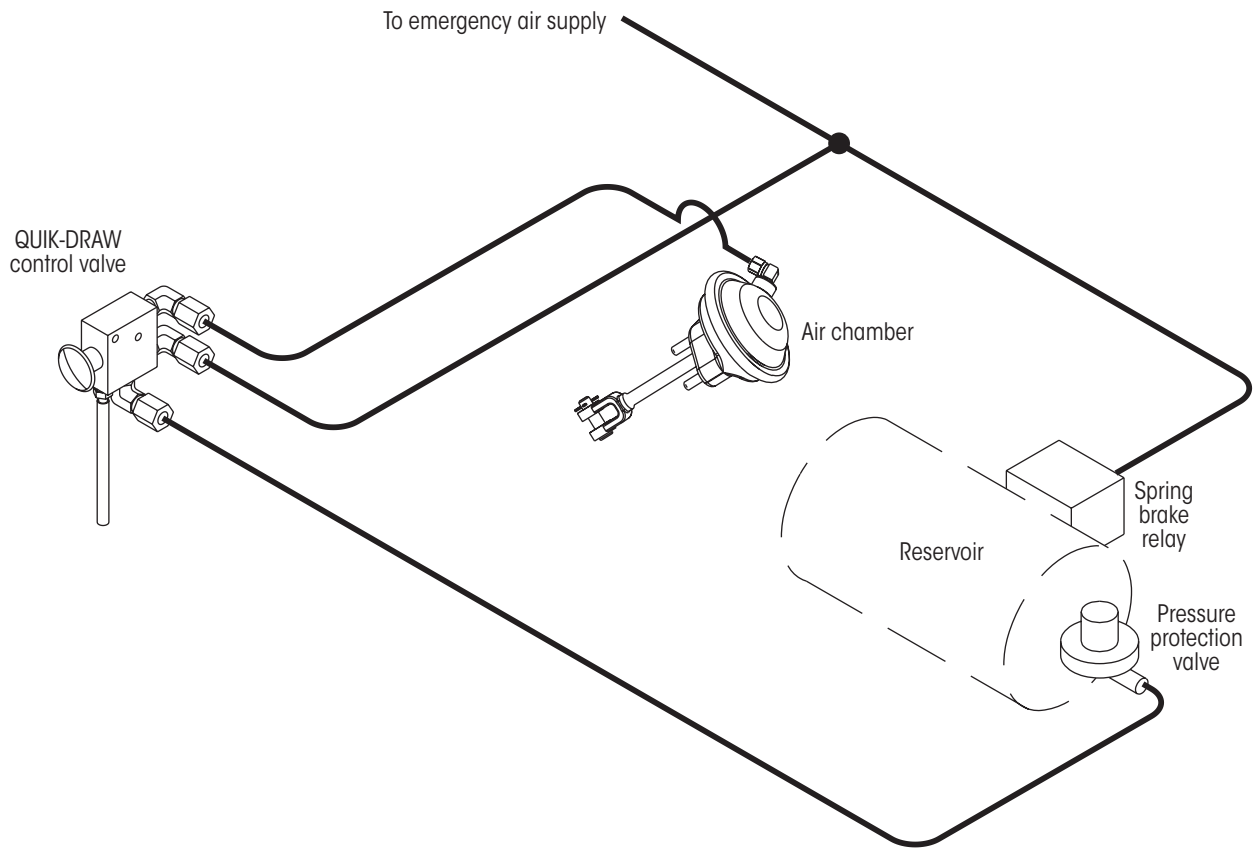

Figure 22: QUIK-DRAW plumbing diagram for platform applications (INTRAAX® SP models)



Actual product performance may vary depending upon vehicle configuration, operation, service and other factors.

Call Hendrickson at 866.RIDEAIR (743.3247) for additional information.



www.hendrickson-intl.com

TRAILER COMMERCIAL VEHICLE SYSTEMS

2070 Industrial Place SE
Canton, OH 44707-2641 USA
866.RIDEAIR (743.3247)
330.489.0045 • Fax 800.696.4416

Hendrickson Canada

250 Chrysler Drive, Unit #3
Brampton, ON Canada L6S 6B6
800.668.5360
905.789.1030 • Fax 905.789.1033

Hendrickson Mexicana

Circuito El Marqués Sur #29
Parque Industrial El Marqués
Pob. El Colorado, Municipio El Marqués,
Querétaro, México C.P. 76246
+52 (442) 296.3600 • Fax +52 (442) 296.3601