

TECHNICAL PROCEDURE

HENDRICKSON TIRE INFLATION SYSTEM

SUBJECT: Installation, Service and
Troubleshooting Procedures

LIT NO: L786

DATE: December 2003 **REVISION:** A

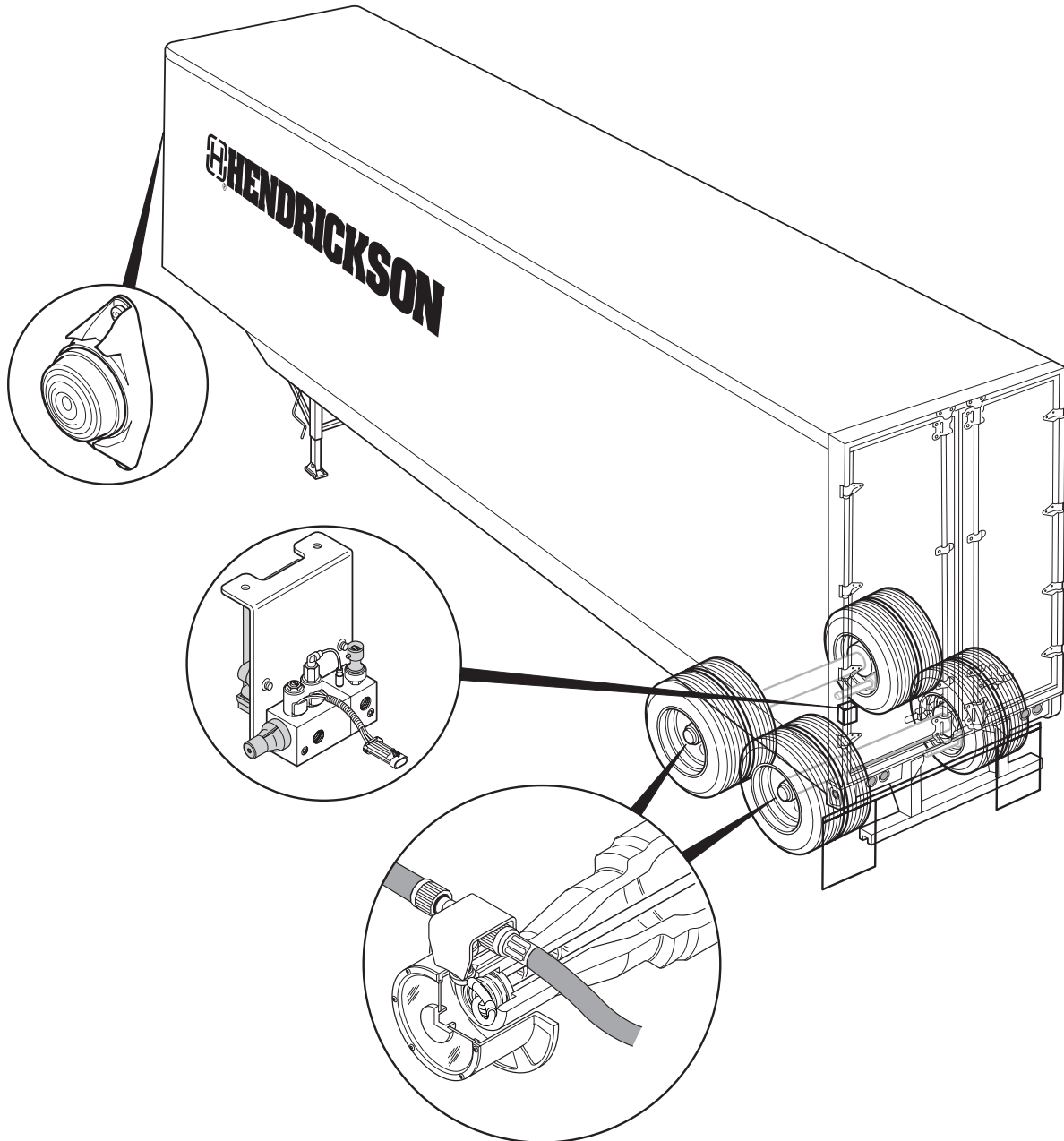

For The Road Ahead™

 **HENDRICKSON**



TABLE OF CONTENTS

General Information	5
About this Manual	5
System Overview	5
Features	5
Data Logging	5
System Specifications	5
Component Weights	5
Operation	6
System Operation	6
Manually Checking Tire Pressure	6
Warning Lamp Description	6
Two Seconds On at Power-Up	6
Multiple Flashes at Power-Up	6
Lamp on Continuously	7
How the System Operates	7
Components	8
Component Description	8
Tire Hose (with integral check valve)	8
Rotary Joint	8
Manifold	8
Electronic Control Unit (ECU)	8
Controller Assembly	8
Installation	10
Installation Materials and Supplies	10
Installation Introduction	10
Axle Preparation	10
Component Installation	12
Axle Hose Installation	13
Spindle Plug Installation	14
Assembling the Rotary Joint (Original Style Rotary Union Only)	15
Hub Installation Requirements	15
Hendrickson Hubcap Spacer Kit Installation	16
Installation of Rotary Joint	16
Original Style Rotary Joint Assembly	16
Alternate Style Rotary Joint Assembly	18
Hubcap Assembly	18
Controller Assembly Installation	19
Wiring Harness Installation	20
Axle Vent Installation	21
Control Line Installation	21
Additional Axles	21
Tire Hose Installation	26
Label Location	27
System Setup	28
Introduction	28
System Learn Method	28
Troubleshooting Learn Mode	29



Service Tool Method	29
Troubleshooting	29
Troubleshooting Introduction	29
Blink-Code Diagnostics	29
Blink-Code Description	30
Troubleshooting Technique	32
Service Procedures	33
Wiring Harness Replacement	33
Controller Assembly Replacement	34
Manifold Assembly Replacement	36
Manifold Air Filter Replacement	37
Electronic Control Unit (ECU) Replacement	38
Pressure Transducer Replacement	39
Wheel Removal and Installation	40
Wheel-End Service (Hub Removal)	41
Rotary Joint Removal	41
Original Style Rotary Joint Assembly	41
Alternate Style Rotary Joint Assembly	41
Rotary Joint Assembly (Original Style Rotary Union Only)	41
Installation of Rotary Joint Assembly	42
Original Style Rotary Joint Assembly	42
Alternate Style Rotary Joint Assembly	43
Hubcap Assembly	43
Glossary	44
Appendix	45



The descriptions and specifications contained in this publication are current at the time of printing.

Hendrickson reserves the right to discontinue or modify its models and/or procedures and to change specifications at any time without notice.

Any reference to brand name in this publication is made as an example of the types of tools and materials recommended for use and should not be considered an endorsement. Equivalent parts may be used.

IMPORTANT NOTICE

Hazard signal words (such as Warning or Caution) appear in various locations throughout this publication. Information accented by one of these signal words must be observed at all times. Additional notes are utilized to emphasize areas of procedural importance and provide suggestions for ease of repair. The following definitions indicate the use of these signal words as they appear throughout the publication.

⚠ WARNING: INDICATES HAZARDS OR UNSAFE PRACTICES WHICH COULD RESULT IN SEVERE PERSONAL INJURY OR DEATH.

⚠ Caution: Indicates hazards or unsafe practices which could result in damage to machine or minor personal injury.

NOTE: Additional service information not covered in the service procedures.

Departure from the instructions, choice of tools, materials and recommended parts mentioned in this publication may jeopardize the personal safety of the service technician or vehicle operator.

Always use genuine Hendrickson replacement parts.

The HTIS system complies with part 15 of the FCC rules and with RSS-210 of Industry Canada. Operation is subject to the following conditions: (1) This device may not cause harmful interference, and (2) this device must accept any interference received, including interference that may cause undesired operation.

Every effort has been made to ensure the accuracy of all information in this publication. **However, Hendrickson makes no expressed or implied warranty or representation based on the enclosed information.**



GENERAL INFORMATION

ABOUT THIS MANUAL

This manual is provided to support the Hendrickson Tire Inflation System (HTIS). The manual provides the following information:

- General Information
- Operation
- Components
- Installation
- Service
- Troubleshooting
- Glossary

SYSTEM OVERVIEW

The Hendrickson Tire Inflation System is designed to automatically inflate tires that are below their cold tire pressure setting using compressed air from the brake supply tank. An integral brake priority valve helps ensure that the brake system always has sufficient air. Air seals and hoses remain non-pressurized when the system is not actively checking or inflating the tires. A warning lamp will turn on when one or more tire pressure(s) is low by 10% or more. The lamp will not turn on for minimal inflation requirements of less than 10%, to help avoid operator distraction when no action is required.

If a tire is low, the remaining tires are protected from pressure loss by integral check-valves located in each tire hose. In addition, should system or tire maintenance be required (i.e., leaky tire resulting in excessive inflation), the lamp will flash multiple times at power-up indicating service is required.

FEATURES

- Lamp on when tires 10% low (programmable)
- Checks tire pressure every 10 minutes
- Non-pressurized lines and seals when not inflating
- Warning lamp on only when service is required (not every inflation)
- Does not pressurize axle tube (helps prevent contamination of air seals)
- Seal and line leaks will not pressurize wheel ends
- No venting at wheel end helps prevent contamination from entering hubcap
- Check-valves located in hoses at tee
- Manual pressure check or fill available at hose end
- Industry standard data link (SAE J1587) for communications and service

- Historical information retained through power-ups
- System stops inflation and logs a service code if an inflate sequence exceeds two hours
- Leaky tire detection
- Atmospheric pressure compensation
- Automatic target pressure learn mode
- Serviceable filter at manifold helps keep lines and seals clean
- System detects and logs service code if no supply air for greater than 24 hours

DATA LOGGING

- Active and historical service codes (clear after 50 resets without reoccurrence)
- Count of inflation events
- Total inflation time
- Total hold time (pressurized)
- Count of power resets
- Total powered time
- Inflation time histogram data
- Pressure below target histogram data

SYSTEM SPECIFICATIONS

- Tire pressure setting range: 80 to 125 psi
- Pressure accuracy: $\pm 1\%$
- Pressure resolution: 0.5 psi
- Pressure protection valve: 80 ± 5 psi
- Pressure check interval: 10 minutes
- Power requirement (at 12VDC): <20 mA idle
1.3 A inflating
- Minimum operating voltage: 9 volts
- Warning lamp current range: 50-350 mA
- Inflate capacity (one tire): 10 psi in approx. two minutes

COMPONENT WEIGHTS

- Controller assembly: 5.5 lbs.
- Wheel-end hardware: 2.0 lbs. per end
- Misc. fittings and air line: 2.0 lbs.
- Wire harness: 2.0 lbs.



OPERATION

SYSTEM OPERATION

To ensure that the system is functioning, the operator should verify that a two-second warning lamp bulb check occurs when the unit is powered. The system is powered from the “blue circuit” on the seven-pin trailer connector.

Once powered, the brake supply tank must be charged before the system will operate. The system will then pressurize the lines and measure the tire pressure. If one or more tires are low, the system automatically inflates the low tire(s) to the cold tire pressure setting. The remaining tires are protected from pressure loss by check-valves located in each tire hose. If one or more tires are low by 10% or more, the warning lamp will turn on and remain on until the tire(s) are reinflated.

Once the tires are at the proper pressure, the seals and hoses will be depressurized, preventing unnecessary wear on the seals. The system rechecks tire pressure every 10 minutes by momentarily pressurizing the lines and measuring tire pressure as described above.

If the warning lamp flashes multiple times on power-up, the system has stored a service code and may be unable to properly check or maintain tire pressure. The operator should manually check tire pressures to ensure that it is safe to operate the vehicle and should seek service at the next opportunity.

If the warning lamp remains on, the system is attempting to inflate the tires but may not be able to adequately maintain proper tire pressure. The operator should stop and check the tires to determine if it is safe to continue to operate the vehicle and should seek service at the next opportunity.

⚠ CAUTION: All hoses must be connected for the system to operate properly. If any of the hoses are removed or damaged, the system cannot inflate any low tire(s).

MANUALLY CHECKING TIRE PRESSURE

⚠ WARNING: TO PREVENT INJURY, ALWAYS WEAR EYE PROTECTION WHEN MAINTAINING OR SERVICING THE VEHICLE.

NOTE: Check valves in the tire hoses help prevent tire pressure loss when a tire hose is removed. You may, however, experience air flow at the open line and a low tire indication on the warning lamp if the tire hose is disconnected and the system is powered and attempts to check tire pressures.

To manually check tire pressure (figure 1):

- Disconnect tire hose from tee at hubcap or from valve stem.
- Use a conventional gage to measure tire pressure at hose end or at valve stem.
- Reattach and firmly hand-tighten tire hose.

⚠ CAUTION: Do not overtighten tire hose or the seal may be damaged. Ensure tire hoses are not stretched or rubbing on the wheel.

WARNING LAMP DESCRIPTION

TWO SECONDS ON AT POWER-UP

This is a system verification and warning lamp bulb check (figure 2). If there is no bulb check at power-up, the system may not be functioning. Verify proper power is applied to the system.

NOTE: The HTIS system utilizes the trailer’s blue circuit for power. Some early model tractors do not power this circuit, resulting in no power to the system.

MULTIPLE FLASHES AT POWER-UP

If the warning lamp flashes multiple times on power-up, the system has stored a service code (refer to the table on page 31 for complete service code details). A service code indicates the need for tire or system maintenance. If this occurs, the system may be unable to properly check or maintain tire pressure. Verify that all tires are inflated properly, and have the system serviced at the next opportunity.

NOTE: Only active service codes cause the warning lamp to blink multiple times at power up.

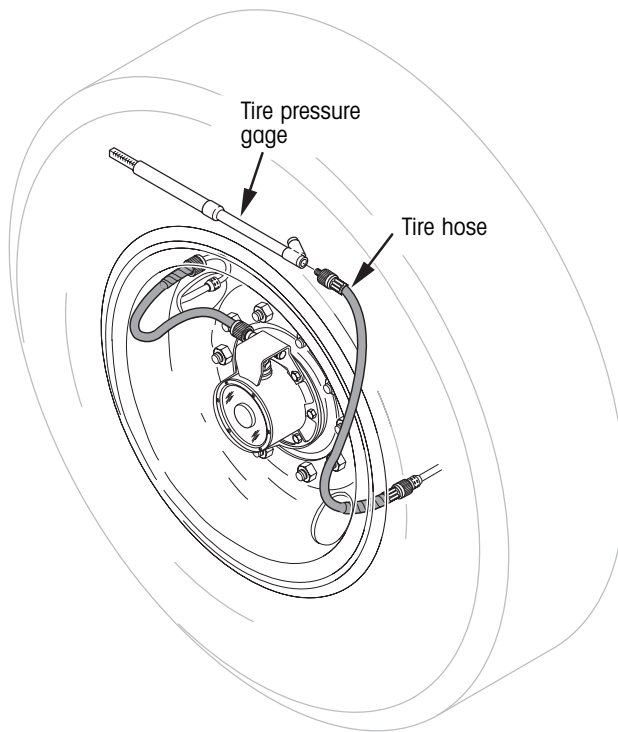

Figure 1. Manually checking tire pressure

LAMP ON CONTINUOUSLY

The lamp will illuminate if the measured pressure of one or more tires is 10% or more below the cold pressure setting. The lamp will remain on until the tires are reinflated to the proper tire pressure. If the lamp remains on for an extended period of time, the operator should stop the vehicle and check the tires for damage.

Under some normal operating conditions, you may find that the warning lamp illuminates when no visible damage is apparent. This may be due to changes in ambient temperature while the trailer is idle. When the system is first powered on a trailer at a temperature significantly lower than when previously operated, cooling of the tires may result in a drop of pressure below 10% of the target pressure, thus illuminating the lamp. Refer to the Appendix (figure 42) for examples of temperature effects on tire pressure.

In addition, the lamp may turn on solid as the result of a significant air line leak, the system failing to depressurize, or because a new ECU has not had a target programmed yet (on ECU's shipped before September 2003).

⚠ CAUTION: Extended periods of use with the lamp illuminated may decrease the life of the rotary air seals.

HOW THE SYSTEM OPERATES

The system checks the tire pressures at 10-minute intervals. To measure the tire pressure, the system charges the air lines with a series of pulses. If the line pressure has not increased to the target tire pressure after a specified period of time, the system will begin to inflate the low tire(s). If the measured tire pressure is 10% or more below the target tire pressure, the warning lamp will illuminate while the system is inflating the tire(s) to inform the driver of a potential tire leak. Once the target tire pressure is achieved, the system performs an additional check to verify that the control lines have depressurized and turns off the lamp.

To prevent air from leaking while the control lines are not pressurized, there is a check valve (no spring valve core) in each of the tire hoses.

If the warning lamp remains lit for an extended period of time, the driver should check all the tires for damage and take corrective actions if applicable.

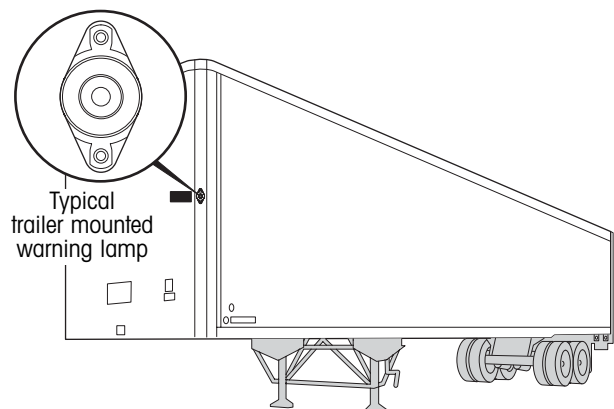

Figure 2. Trailer mounted warning lamp



COMPONENTS

COMPONENT DESCRIPTION

Refer to figure 3 for major HTIS component illustrations. Refer to figures 19 through 23 for a complete description of air fittings and hoses.

TIRE HOSE (WITH INTEGRAL CHECK VALVE)

- Provides an air passage from the hubcap tee to the tire
- Integral check valves in the tire hoses allow the air lines and seals to remain non-pressurized when the system is not checking or inflating the tires
- No modification to the standard valve stem or core is required
- Allows for manual pressure check and fill at the hose end

ROTARY JOINT

- Provides a means to allow the air to flow from a non-rotating axle spindle to the rotating hubcap
- The rotary joint is composed of seals and bearings. The air seal prevents leakage from the rotating shaft and the oil seal guards against contamination
- Provides a vent for air pressure in the hubcap during normal use and in the event of rotary joint damage
- Under normal operation, the rotary joint will be non-pressurized for the majority of the time

MANIFOLD

- Pressure protection valve ensures air supply is not used below 80 psi
- Serviceable inlet filter reduces contamination from the air source
- Solenoids control the flow of air to tires
- Pressure transducer reads tire pressure

ELECTRONIC CONTROL UNIT (ECU)

- Controls the manifold to read and maintain tire pressures
- Performs a lamp check to inform the driver that the system is powered and operational
- Turns on the warning lamp when the measured tire pressure drops more than 10% (typical value) below the target pressure
- Detects faults and displays service codes via the warning lamp
- Provides on-board diagnostic support over an industry standard SAE J1708/J1587 communications interface
- Provides diagnostic support via blink codes
- Stores historical data for future use

CONTROLLER ASSEMBLY

- Manifold
- ECU
- Mounting bracket
- Beginning in September of 2003, the controller assembly began shipping with the target inflation pressure already programmed to 95 PSI. These "preprogrammed" controllers are identified with a letter "P" marked on the end of the valve body. With these preprogrammed controllers, no programming is required to enable the HTIS system to function unless a target inflation pressure other than 95 PSI is desired. In that case, refer to the System Setup section for complete controller programming details.

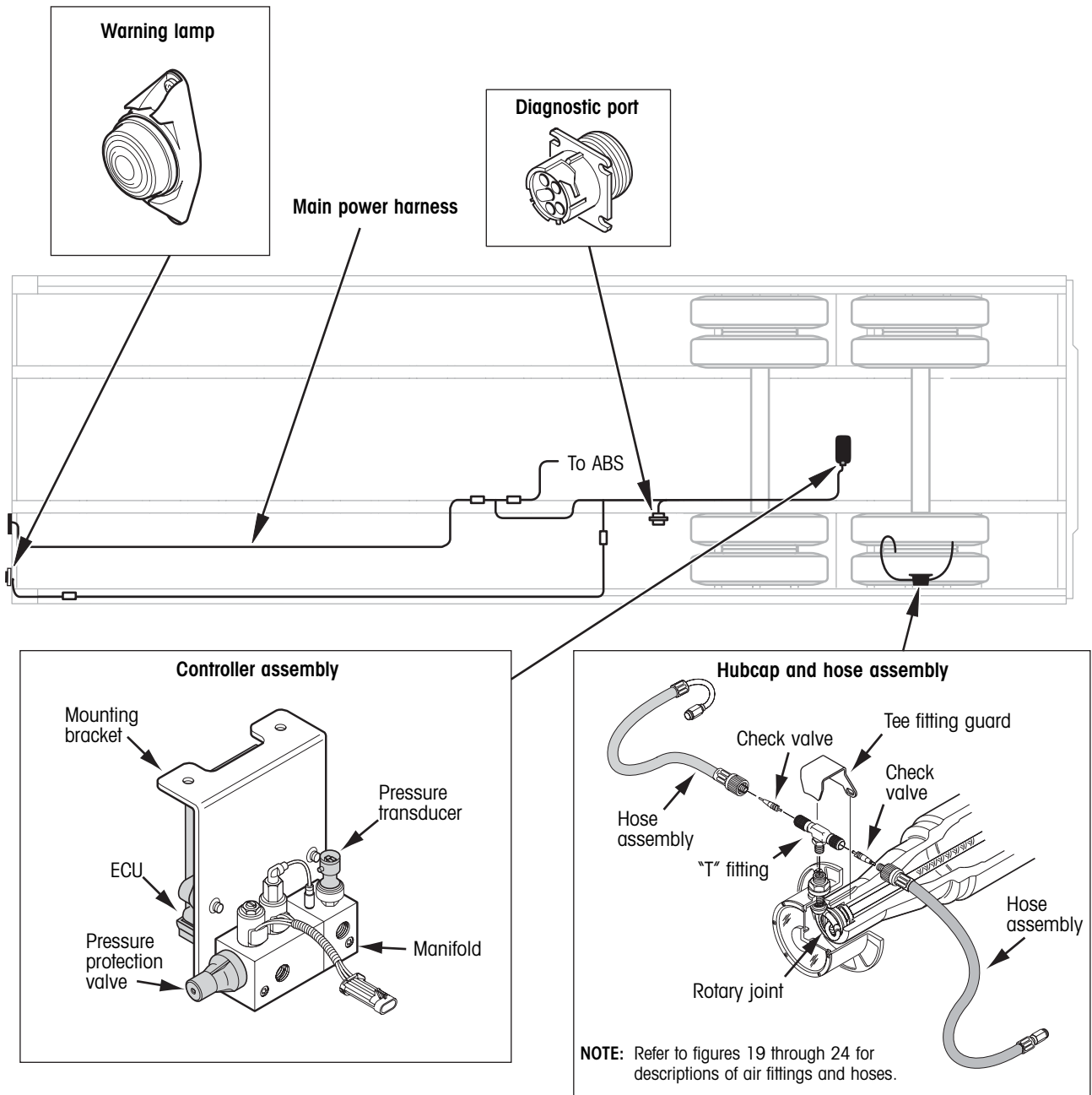

Figure 3. HTIS components



INSTALLATION

INSTALLATION MATERIALS AND SUPPLIES

In addition to the hardware provided, the installer shall provide the following:

- Hubcap (unless pre-installed on dressed axle)
- Spindle plug driver and handle (figure 9), unless plugs are already installed in the axle from the factory
- Air lines and fittings (figures 20-23)
- Warning lamp and wire (figure 18)
- 115 psi shop air or PC/hand-held tool to set target tire pressure
- Optional J560 to five-pin extension harness if trailer is pre-ABS (figure 43)
- Controller assembly mounting bolts (figure 17)

INSTALLATION INTRODUCTION

Identify the bullet item below that describes the condition of your trailer axles and proceed as directed.

- If the HTIS system hardware is already installed on a fully dressed axle, skip to the section titled *Controller Assembly Installation* on page 19.
- If the HTIS system axle hose and spindle plugs are already installed on the axle, skip to the section titled *Assembling the Rotary Joint* on page 15.
- If the axles have been pre-drilled but no hardware has been installed, skip to the section titled *Component Installation* on page 12.
- For retrofit installations, start with the procedures described below.

AXLE PREPARATION

The following describes the procedure for preparing a Hendrickson trailer axle (figure 4) for HTIS system installation.

NOTE: The HTIS system is not compatible with the castle (cotter pin-locked) spindle nut system.

⚠ WARNING: BLOCK ALL WHEELS BEFORE BEGINNING THIS INSTALLATION PROCEDURE. NEVER WORK UNDER A VEHICLE SUPPORTED ONLY BY A JACK.

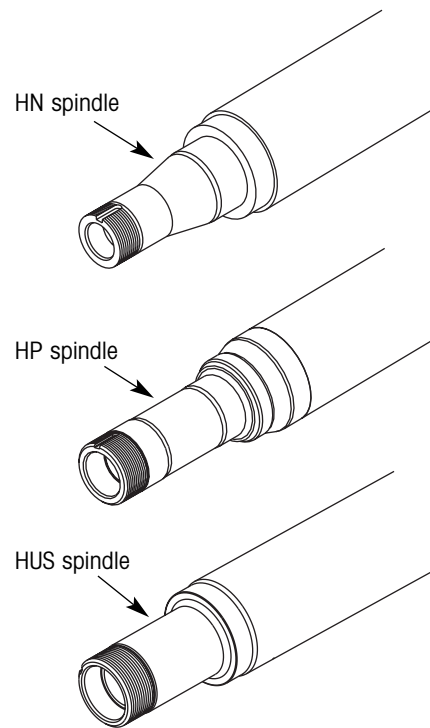

Figure 4. Axle spindle identification

1. Block the tires to keep the trailer from moving (figure 5).
2. Exhaust the air system.
3. If the wheel end is oil lubricated, drain the oil from the hubcap and discard the oil.
4. Remove the hubcap bolts and hubcap.

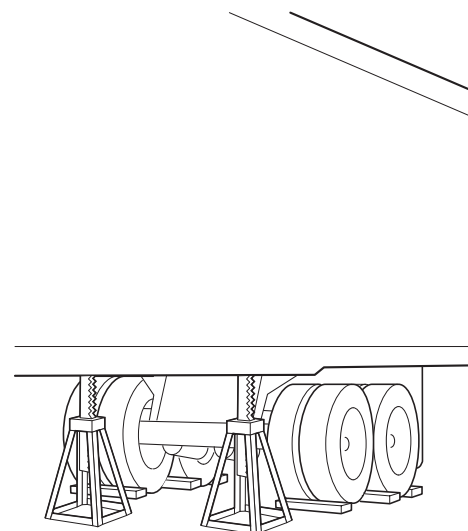
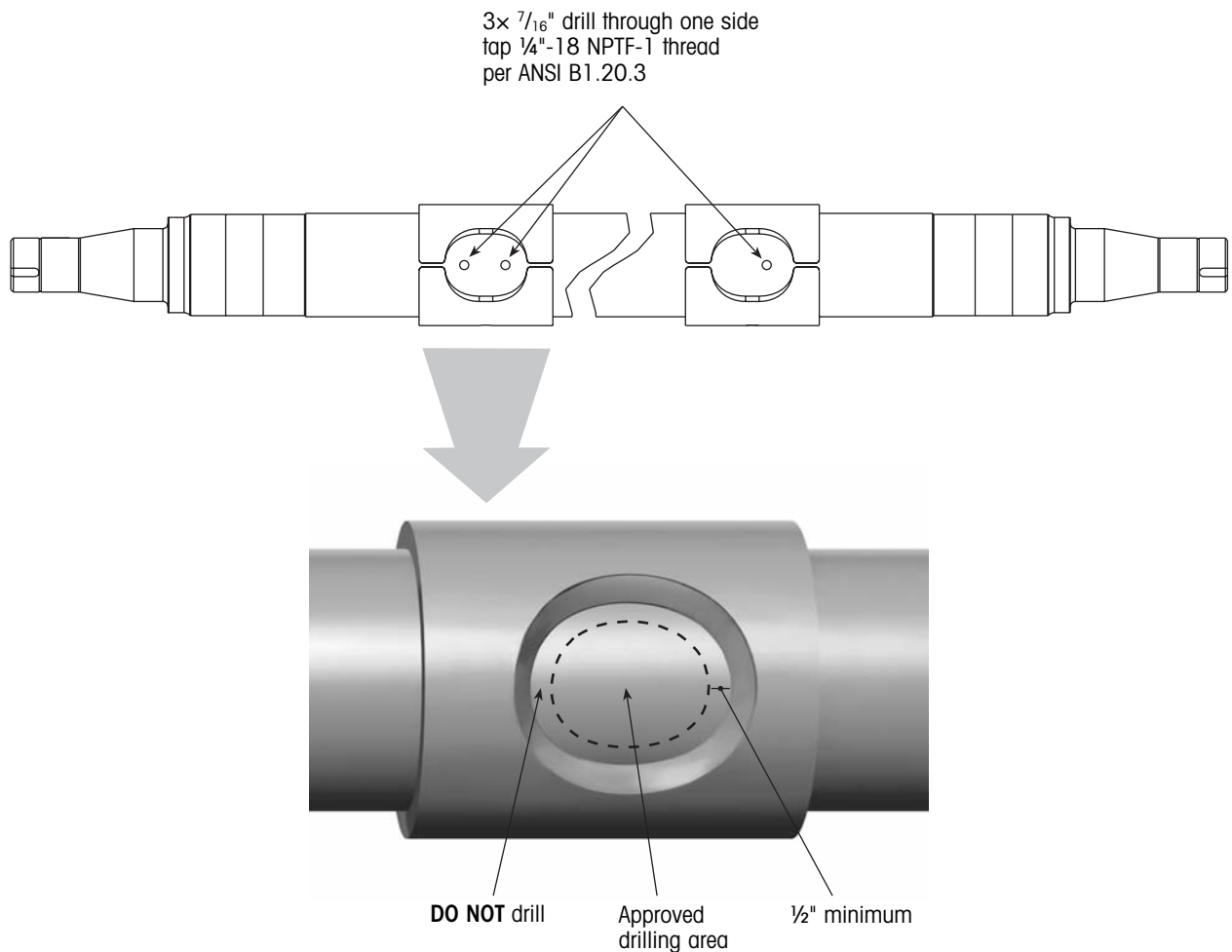

Figure 5. Trailer preparation



5. Remove the spindle plug from the spindle.
6. Remove the in-axle filter.
7. Inspect the spindle plug bore and remove any burrs or sealant.
8. Check the inside of the spindle to insure that there is a passage through the axle to allow installation of the air line.
9. Locate the three ¼-inch pipe plugs on the top surface of the axle tube and remove. If the axle does not have the three ¼-inch pipe thread holes, proceed to step 11.
10. Proceed to the *Component Installation* section.
11. Using the information in figure 6, drill and tap three ¼-inch NPT holes in the axle to prepare for component installation.



IMPORTANT: The edge of any hole must be a minimum of ½ inch away from the edge of the fillet weld that surrounds the wrap window.

NOTE: One wrap window will have two holes (the second hole accommodates an axle vent assembly). These holes must be within the approved drilling area but spaced far enough apart to allow 90-degree elbow fittings to be threaded into them.

Figure 6. Hendrickson axle drilling details

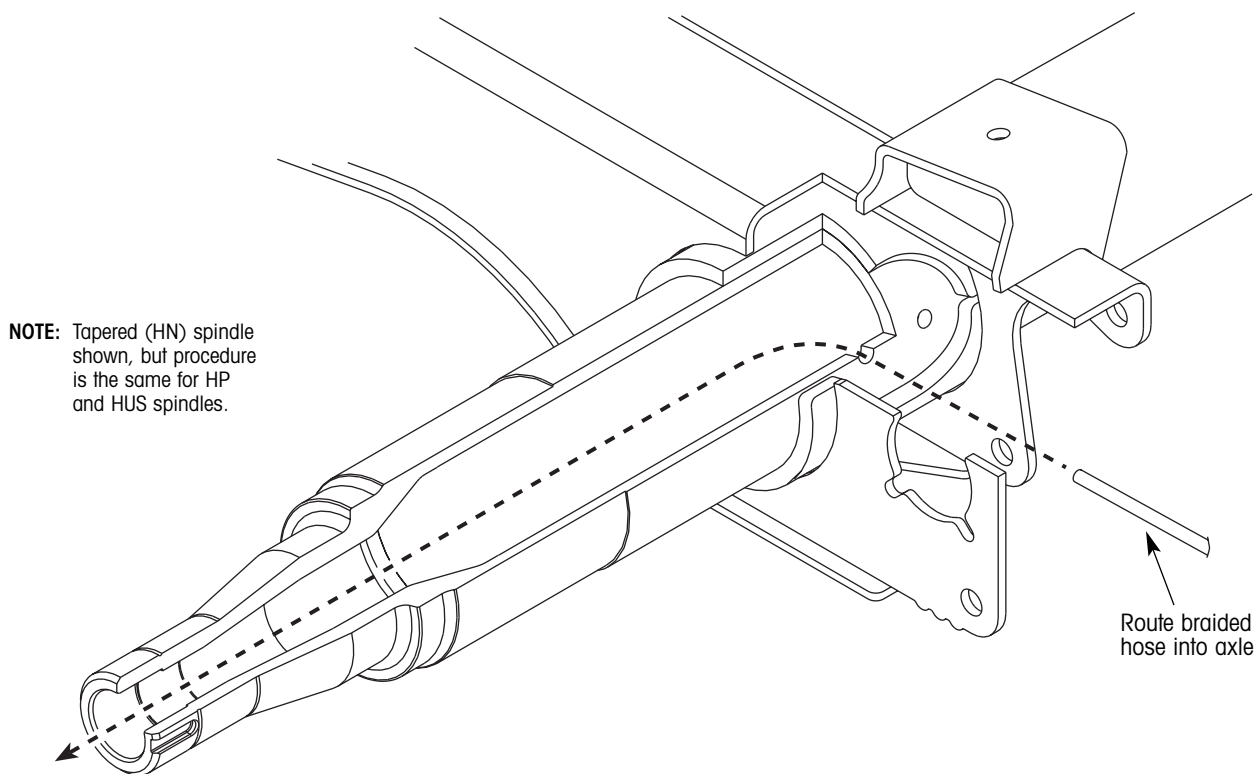

Figure 7. Routing hose in axle

NOTE: In most cases, it will be necessary to remove the slack adjuster and camshaft to gain access to the approved drilling area. Refer to Hendrickson publication L496, *INTRAAX® Wheel-End Maintenance Procedures* (available at www.hendrickson-intl.com), for complete slack adjuster and camshaft removal instructions.

NOTE: Remove the debris generated by the drilling and tapping operations from inside the axle before proceeding with the next step.

12. Proceed to the *Component Installation* section.

COMPONENT INSTALLATION

Refer to the following assembly procedures to complete the installation of the Hendrickson Tire Inflation System. Component installation procedures include:

- Axle hose installation
- Spindle plug installation
- Rotary joint assembly and installation
- Hubcap assembly
- Controller assembly installation
- Wiring harness installation
- Axle vent and control line installation
- Tire hose installation
- In-axle filter installation



NOTE: Tapered (HN) spindle shown, but procedure is the same for HP and HUS spindles.

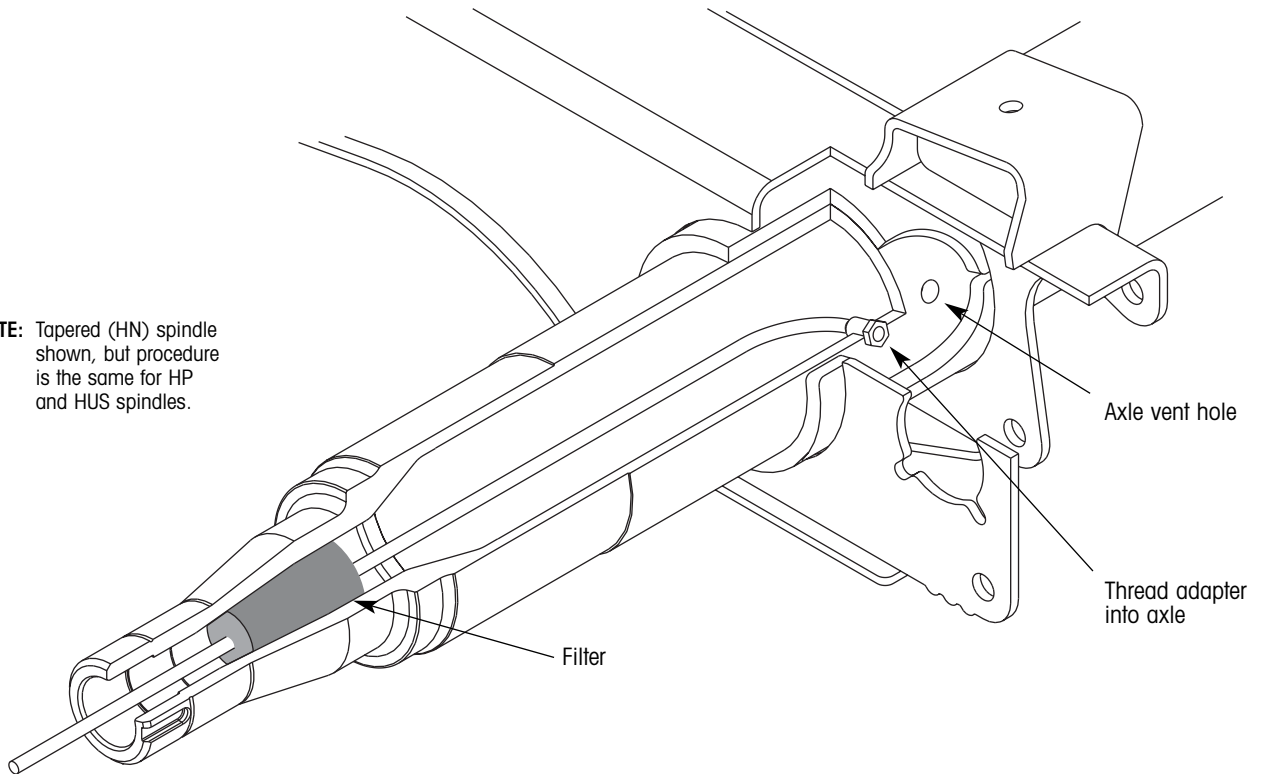

Figure 8. Installed position of hose assembly

AXLE HOSE INSTALLATION

1. On the end of the axle tube with two ¼-inch holes in the wrap window, route the small covered end of the metal braided hose into the hole closest to the spindle end (figure 7).
2. Making sure that the hose heads toward the spindle end, continue feeding the metal braided hose into the axle tube until the small end of the hose exits the spindle end.
3. Thread the large adapter end of the axle hose assembly into the axle and tighten to 20 ft. lbs. (27.1 N•m) of torque (figure 8).
4. Remove the protective coverings from the end of the axle hose assembly and blow air through the hose assembly to remove any debris.
5. Cut an inch-wide slit in the center of the axle filter and feed the metal braided hose through the slit in the filter. Push the axle filter into the spindle cavity (figure 8).
6. Repeat steps one through five on the other end of the axle. Leave the axle vent hole (figure 8) vacant for now. This hole will be used to accommodate the axle vent in a later installation.

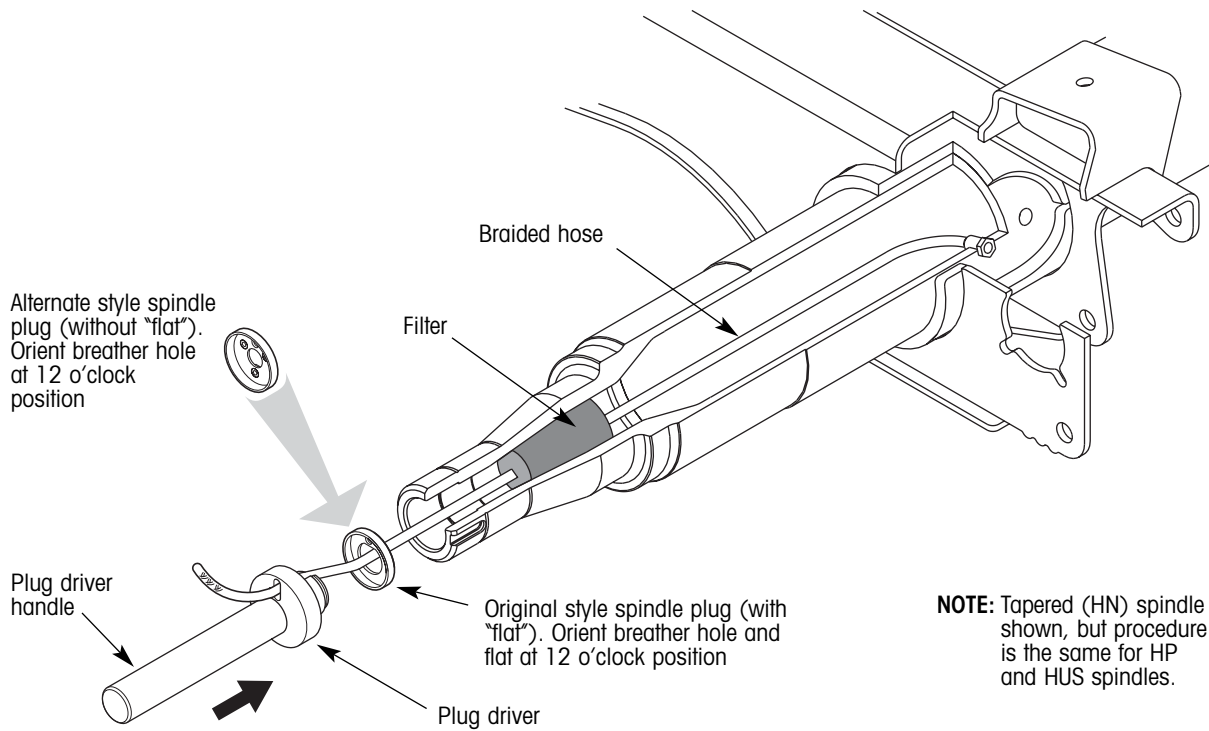

Figure 9. Spindle plug installation

SPINDLE PLUG INSTALLATION

1. On one end of the axle, route the end of the braided hose through the center of the spindle plug (figure 9).
2. With the spindle plug breather hole (alternate style spindle plug) or with the spindle plug breather hole and "flat" (original style spindle plug) in the 12 o'clock position (with the suspension at ride height), place the plug assembly against the spindle end.

3. Route the braided hose through the slot in the plug driver and press the plug into the spindle end until the driver bottoms on the end of the spindle.

NOTE: The driver regulates the correct installation depth.

4. Repeat steps one through three on the other end of the axle.

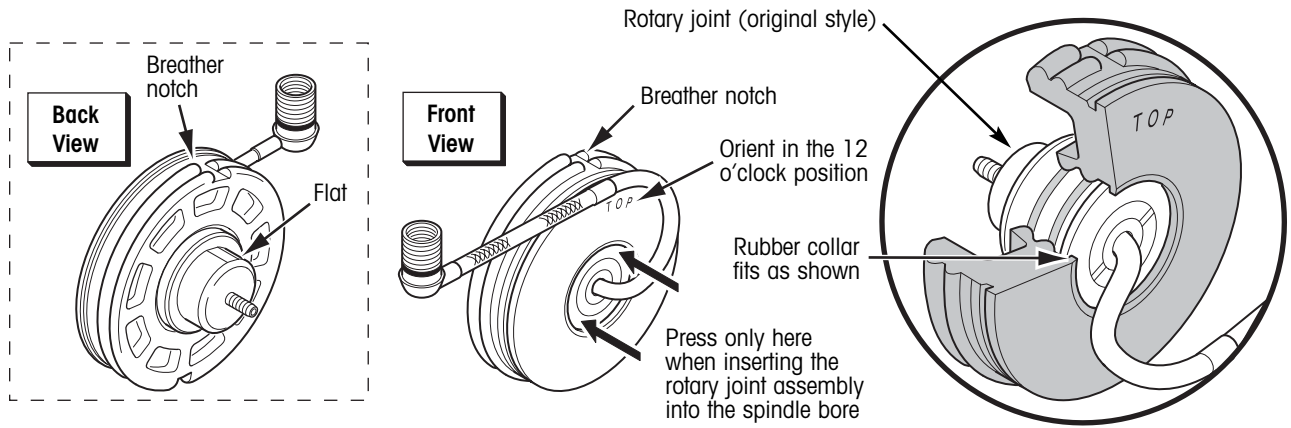

Figure 10. Original style rotary joint assembly

ASSEMBLING THE ROTARY JOINT (ORIGINAL STYLE ROTARY UNION ONLY)

1. If necessary, install the rotary joint in the rubber collar. Align the breather notch in the rubber collar with the flat on the rotary joint (figure 10).

HUB INSTALLATION REQUIREMENTS

A minimum hub bore depth is required when installing the HTIS system (figure 11a). This hub requirement helps keep the proper clearance between the rotary joint assembly and the spindle nut system (figure 11b), thus preventing contact or interference between these parts which could result in wheel-end failure.

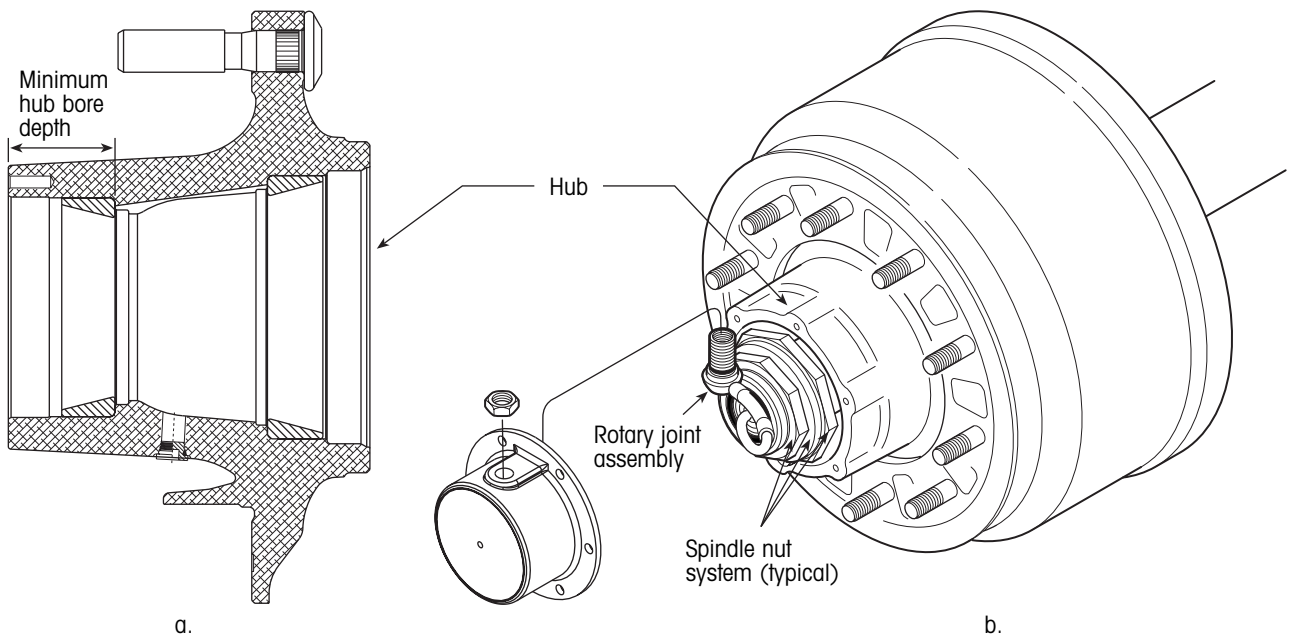
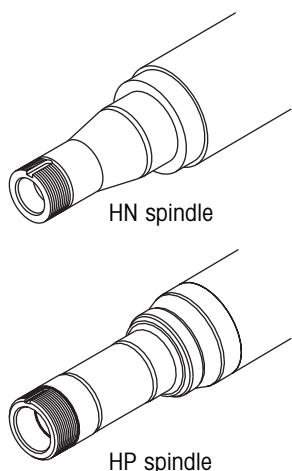

Figure 11. HTIS hub requirement



Dimension "A" is the minimum hub bore depth required to install the HTIS system and is measured from the bottom of the bearing cup to the hubcap mounting surface.

SPINDLE NUT SYSTEM	"A" SPINDLE TYPE	
	HN	HP
Standard three-piece	1.52"	1.44"
Stemco PRO-TORQ one-piece	1.69"	1.87"

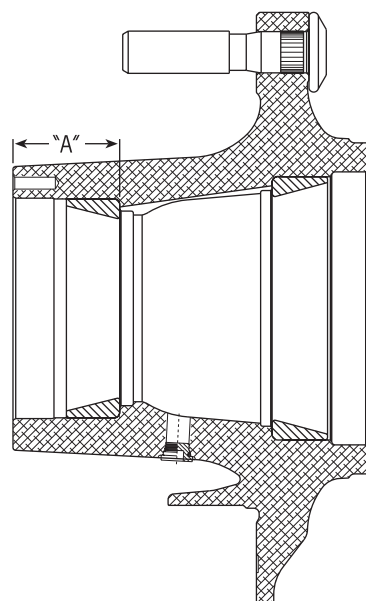

Figure 12. Minimum hub bore depth

Any hub may be used with the HTIS system, provided a minimum hub bore depth requirement (dimension "A" in figure 12) is maintained.

If the hub bore dimension is greater than or equal to the dimension shown in the chart in figure 12, you may use the hub "as is" with the HTIS system.

If the hub bore dimension is less than the dimension shown in the chart in figure 12, you may still use the hub with the HTIS system, but a Hendrickson hubcap spacer kit is required.

Hendrickson offers hubcap spacer kits for HN and HP spindles to accommodate most hubs without the required bore dimension. Each kit consists of 3/8-inch spacers, gaskets, hubcap bolts and lock washers in enough quantities to adapt one axle. The hubcap spacer kit part numbers are as follows:

SPINDLE TYPE	HUBCAP SPACER KIT PART NUMBER
HN	S-28040
HP	S-28093

HENDRICKSON HUBCAP SPACER KIT INSTALLATION

If the hub you intend to use does not meet the minimum hub bore depth requirement for the HTIS system, use the following procedure to install the hubcap spacer kit.

1. Sandwich the spacer between two gaskets as shown in figure 13.
2. Install the hubcap using the bolts and lock washers provided in the kit. Tighten the hubcap bolts to 12-18 ft. lbs. (16-24 N•m) of torque.

INSTALLATION OF ROTARY JOINT

NOTE: The hubs and drums should be installed before installing the rotary joint assemblies.

1. On one end of the axle, place the stepless ear clamp onto the braided hose assembly sticking out of the spindle (figure 14).
2. Slide the barbed end of the rotary joint assembly into the end of the braided hose assembly until the hose bottoms on the rotary joint body.
3. Using a crimping tool (Oetiker® pliers), squeeze the clamp to tighten the hose to the rotary joint.

NOTE: The rest of the rotary joint installation procedure depends on rotary joint assembly style. Each style is described as follows:

Original Style Rotary Joint Assembly

NOTE: To make installation easier in the next step, apply a small amount of lubricant (grease or oil) to the inside bore of the axle spindle.

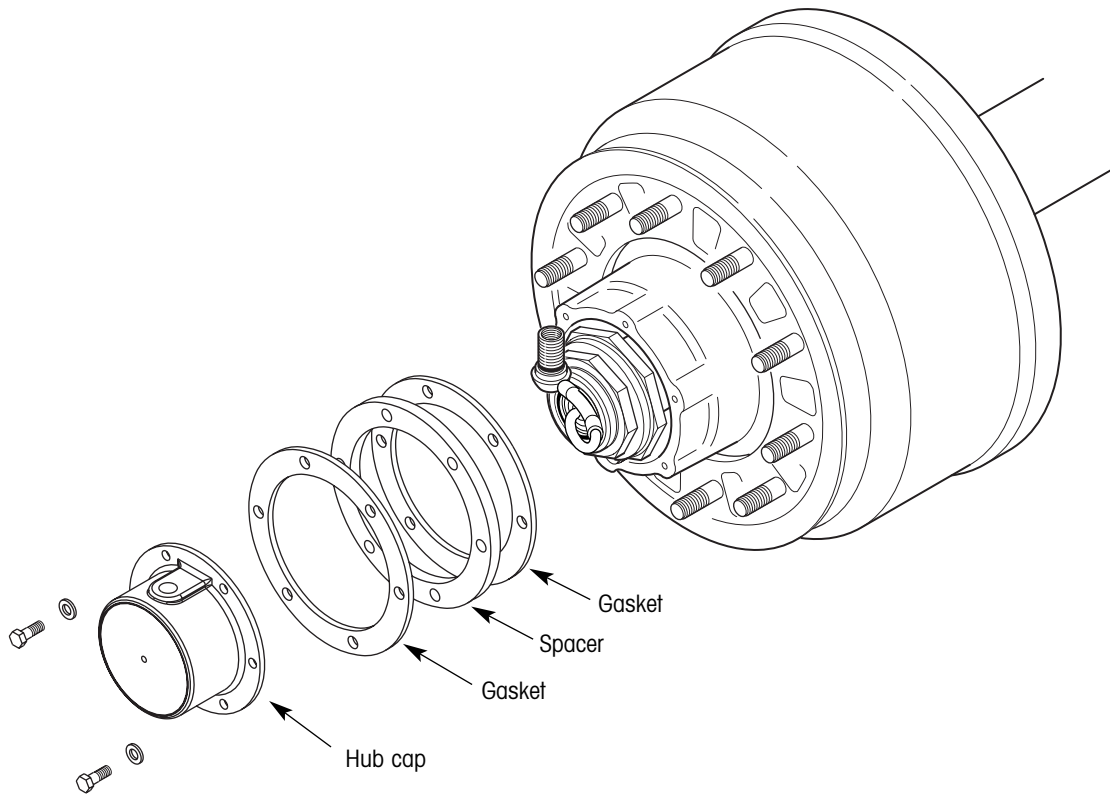

Figure 13. Hubcap spacer kit installation

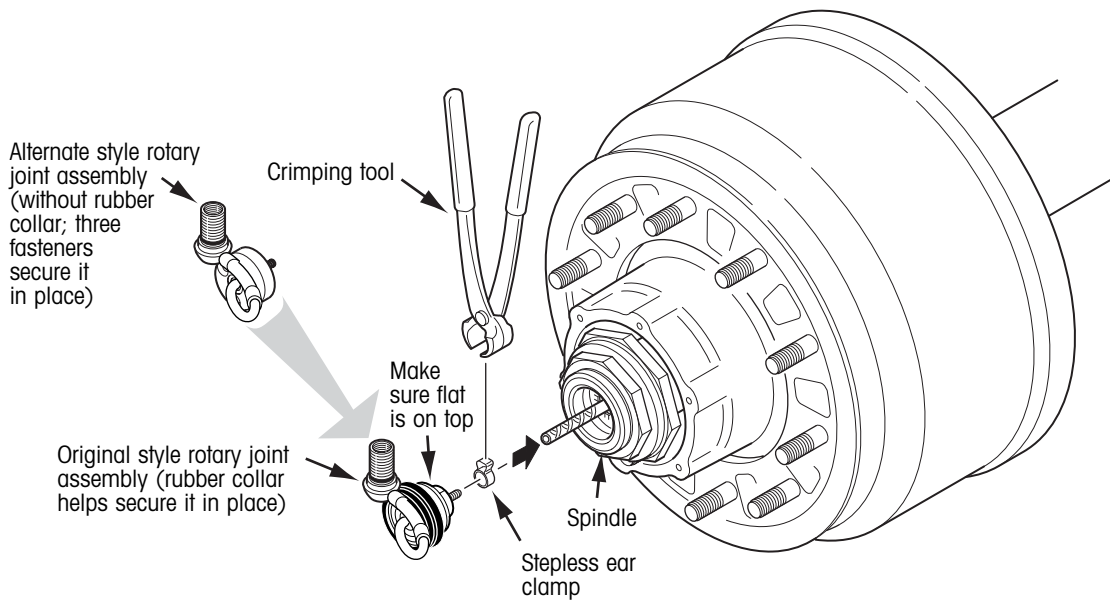

Figure 14. Rotary joint installation



⚠ CAUTION: When inserting the rotary joint assembly into the spindle bore in the next step, do not push on the steel air tube. Carefully push only on the face of the rotary joint where it meets the rubber collar (figure 10).

- Check the orientation of the breather notch in the rubber collar. Make sure it aligns with the flat on the rotary joint body. Orient the flat on the rotary joint body (located near the clamp) to the 12 o'clock position and press the rotary joint assembly into the spindle bore. The assembly is seated when the outer edge is almost flush with the end of the spindle (figure 15).
- Lightly pull on the rotary joint assembly with your fingers to ensure it has been properly inserted into the spindle plug assembly.
- Rotate the rotary joint assembly one full revolution. Make sure that the steel air tube does not contact any part of the spindle or spindle nut system.
- Repeat on the other side of the axle.

Alternate Style Rotary Joint Assembly

- Insert the three fasteners into the rotary joint assembly and fasten to the spindle plug (figure 15a). Tighten the fasteners to 45 ±5 in. lbs. (5 ±½ N•m) of torque.
- Rotate the rotary joint assembly one full revolution. Make sure that the steel air tube does not contact any part of the spindle or spindle nut system.
- Repeat on the other side of the axle.

HUBCAP ASSEMBLY

- Place a hubcap gasket over the rotary joint exit tube and bulkhead adapter.
- Lubricate the O-ring on the rotary joint bulkhead adapter.
- From the inside, insert the bulkhead adapter through the hole in the hubcap labeled "Air". Attach the jam nut and hand tighten (figure 16).

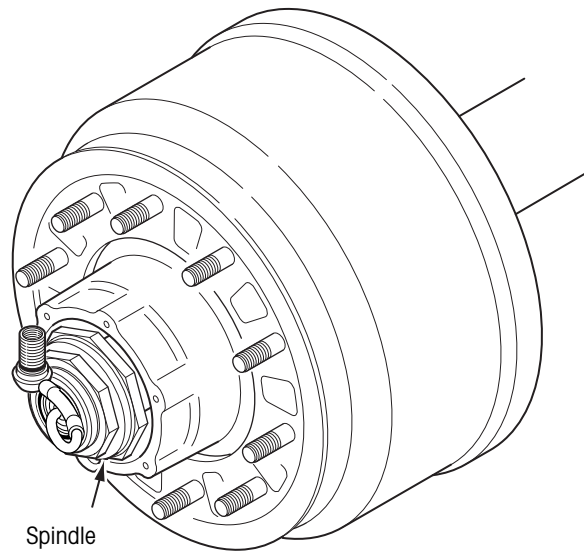

Figure 15. Completed installation of rotary joint assembly

NOTE: If wheels are installed, refer to figure 24 to determine the correct "clocking" of the hubcap. The wheel must be properly "clocked" to the hubcap to prevent the hoses from rubbing on the wheel. Failure to properly "clock" the wheels may result in hose failure.

- Install the hubcap. If the hubcap is a screw-on style used on the HUS hub, tighten it to 50-100 ft. lbs. (68-137 N•m) of torque. If the hubcap is a bolt-on style used on the other hubs, tighten the hubcap bolts to 12-18 ft. lbs. (16-24 N•m) of torque.

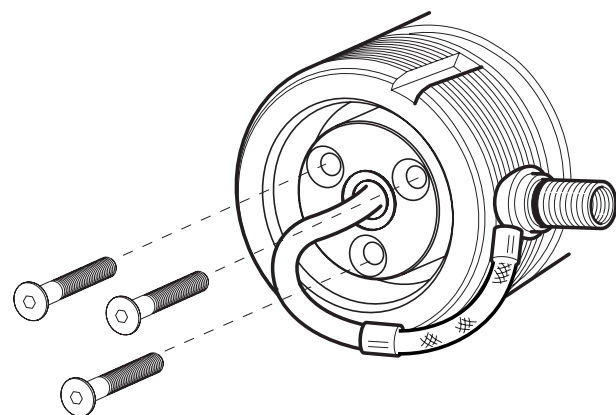

Figure 15a. Alternate style rotary joint assembly

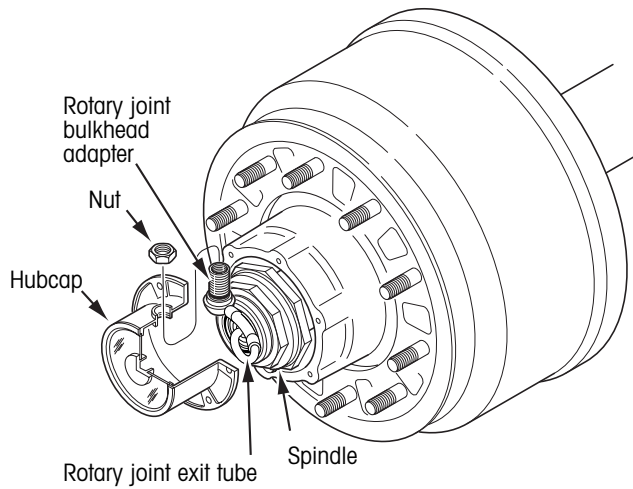

Figure 16. Hubcap to bulkhead adapter connection

5. Tighten the rotary joint jam nut to 15 ft. lbs. (20 N•m) of torque.
6. For oil filled hubs, install lubricant in the wheel end to the correct level.

CONTROLLER ASSEMBLY INSTALLATION

1. Pick a mounting location for the controller assembly so that it can be conveniently connected to the air supply tank.
2. Drill two holes on four-inch centers to accommodate the mounting bracket. Attach the controller assembly with two ⁵/₁₆-inch fasteners (figure 17).

⚠ CAUTION: The controller assembly must be mounted vertically with the ECU connector down (figure 17). This properly orients the exhaust port to prevent damage.

⚠ CAUTION: Do not weld on the controller assembly mounting bracket without first removing both ECU and manifold from the bracket. Refer to the Service Procedures section beginning on page 33 for ECU and manifold removal instructions.

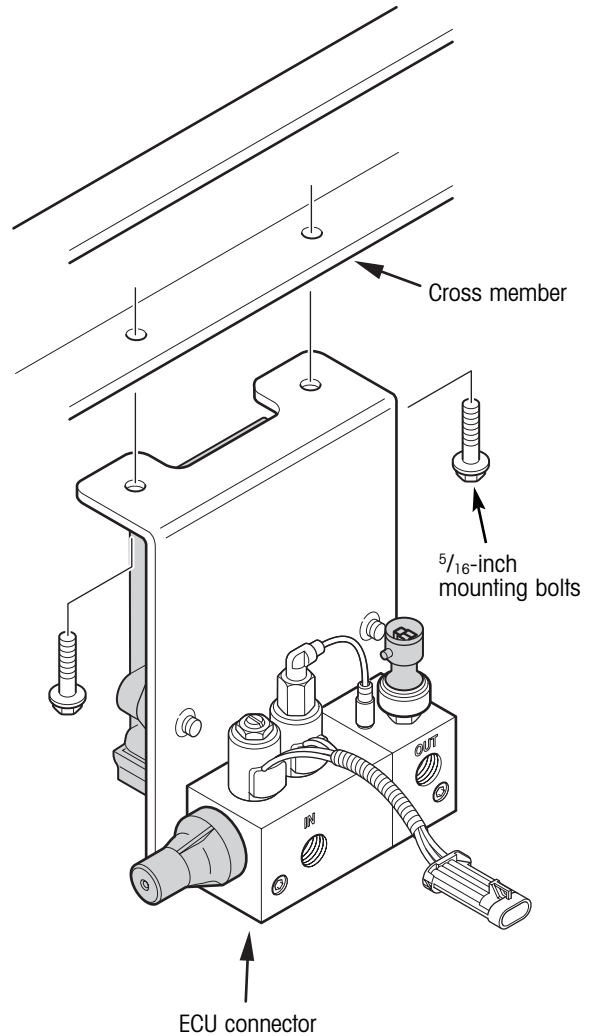

Figure 17. Controller assembly installation

⚠ CAUTION: Cover controller assembly prior to painting or undercoating the trailer to prevent plugging of manifold and ECU ports.



WIRING HARNESS INSTALLATION

1. Plug the power input connector on the HTIS harness into the five-pin Packard connector coming from the J560 interface (figure 18).
2. Plug the cable from the ABS wire harness into the five-pin Packard ABS connector on the HTIS harness.
3. Route the HTIS harness to connect to the ECU, manifold, and pressure transducer located on the controller assembly.
4. Mount the diagnostic connector to the side of the trailer, typically in front of the tires. For slider applications, make sure to allow for adequate movement of the slider.
5. Mount the warning lamp on the front corner or side of the trailer within view of the operators

side view mirror. On tractor applications with large wind fairings, locating the warning lamp near the left rear wheels (near the ABS warning lamp) may be preferable. Connect one side of the warning lamp to ground.

6. Route the warning lamp power wire (16 AWG minimum) and connect to the .156-inch female warning lamp bullet connector on the HTIS harness.
7. Secure harness as required.

NOTE: For pre-ABS equipped trailer retrofits, a power harness is also available. When using this harness, cut the cable to length as required and connect to vehicle power at the SAE J560 connector.

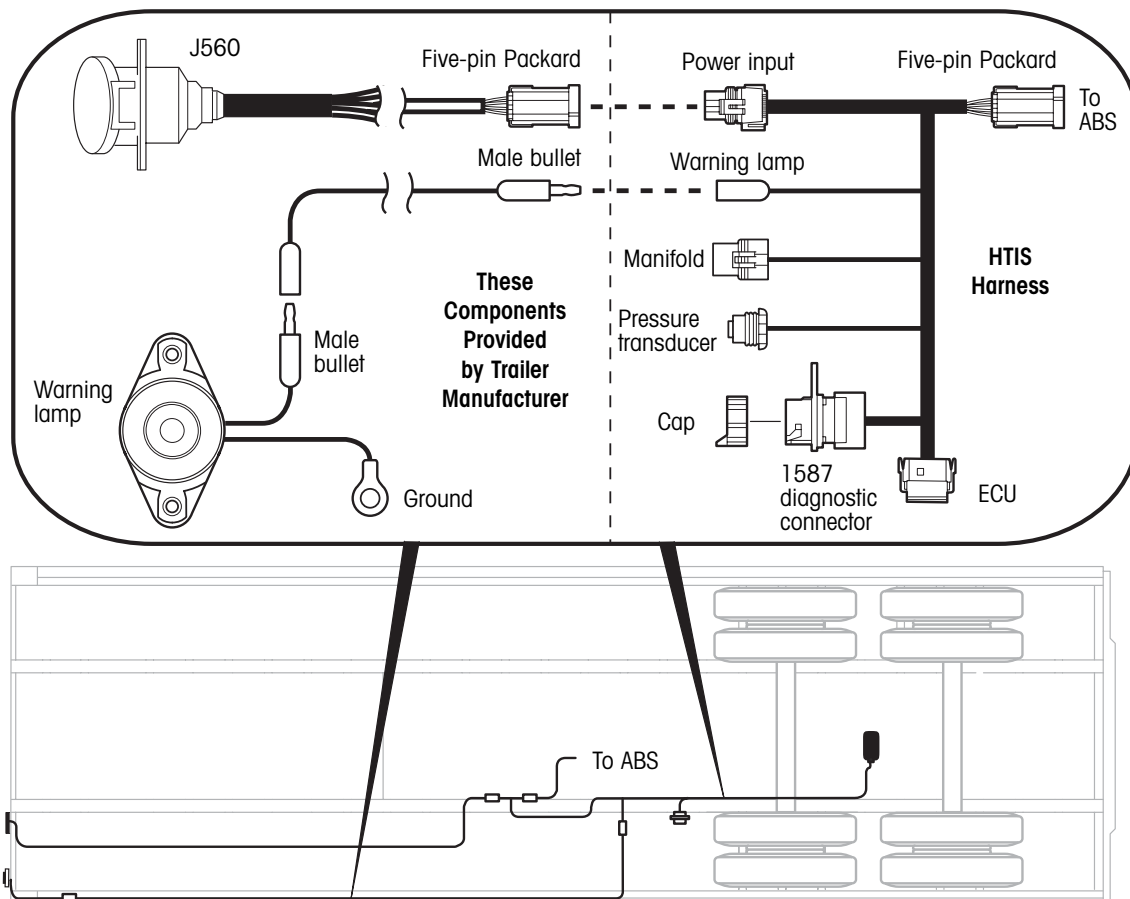

Figure 18. Trailer wiring harness installation

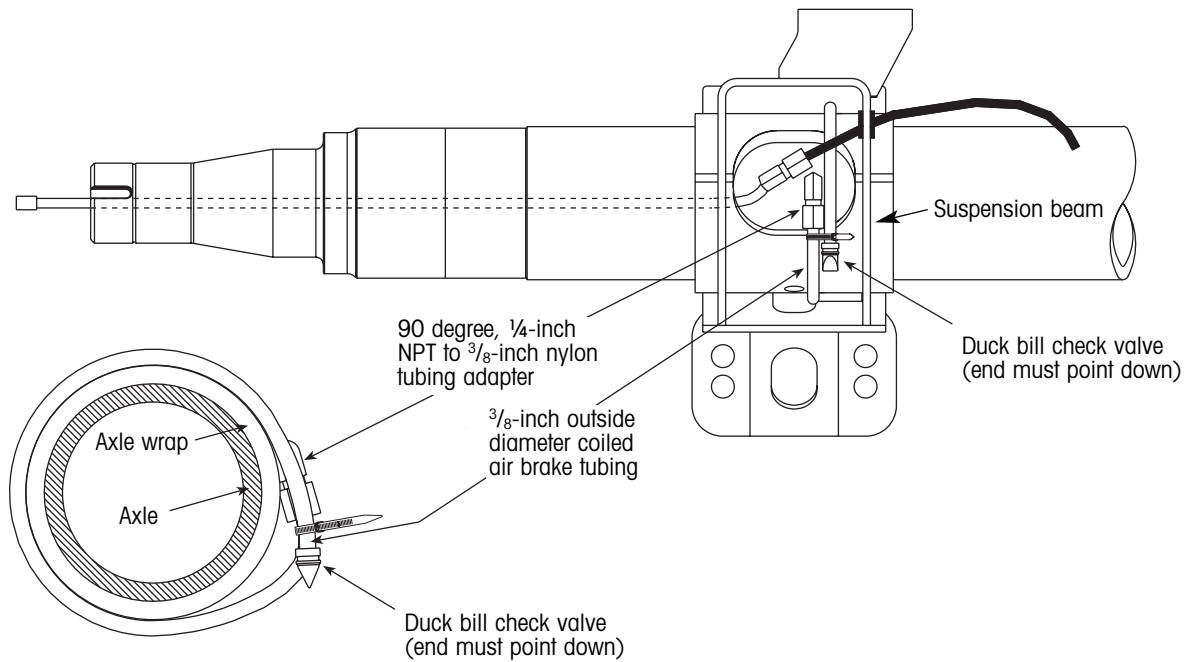

Figure 19. Typical axle vent installation

AXLE VENT INSTALLATION

1. Install a 90 degree, 1/4-inch NPT male to 3/8-inch nylon tubing adapter in the remaining 1/4-inch threaded hole in the axle tube (figure 19).
2. Loop the 3/8-inch outside diameter coiled air brake tubing around the axle but inside the suspension beam. Attach the duck bill check valve to the tubing making sure the end points down to prevent contamination (figure 19).

⚠ CAUTION: To prevent contamination of the axle, ensure the adapters and the duck bill check valve are securely fastened and watertight.

⚠ CAUTION: Failure to properly install axle vent may result in wheel end pressurization and/or water ingestion which could cause wheel end failure.

CONTROL LINE INSTALLATION

Proper Hendrickson Tire Inflation System operation requires correct air line diameters and lengths. The following diagrams (figures 20-23) show air brake tubing lengths and sizes and associated fittings required to complete the system installation. Control line routing recommendations are also included.

⚠ CAUTION: To prevent twisting the air line inside the axle when tightening fittings to the axle hose fitting, use a wrench to hold the axle hose fitting.

⚠ CAUTION: Proper HTIS operation requires correct air line diameters and lengths. Installation sizes and lengths must be within limits shown.

⚠ CAUTION: Proper HTIS operation requires correct air line connections. All junctions of two or more 1/4-inch lines must increase to 3/8-inch line for adequate air flow.

⚠ CAUTION: To prevent HTIS contamination, do not install fittings on the bottom of the air supply tank.

ADDITIONAL AXLES

For systems with three or four axles, observe the installation requirements as shown in the following diagrams (figures 20-23). Extend the main 3/8-inch run as necessary. However, all total line lengths must still remain within the limits listed in the diagrams.

NOTE: All junctions of two or more 1/4-inch lines must increase to 3/8-inch line to maintain adequate air flow.

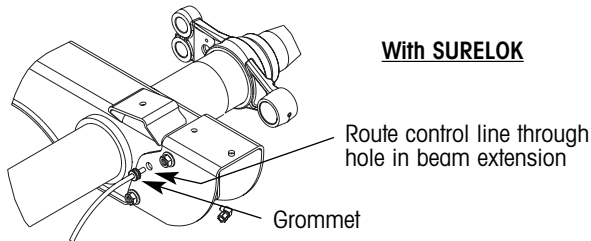
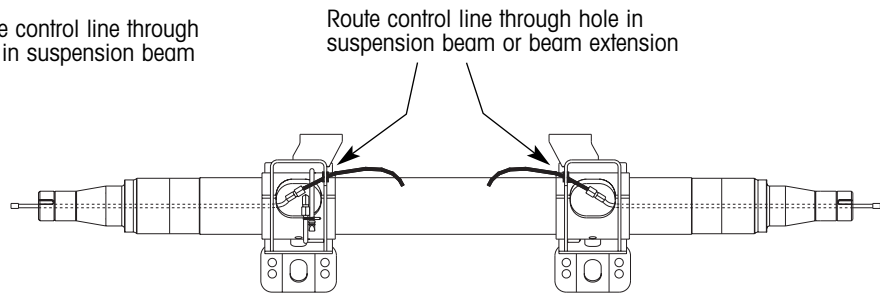
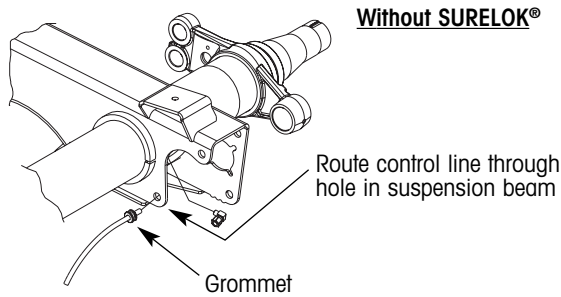

Top Mount, Wide Bushing Models (AAT, AAEDT, HKAT)

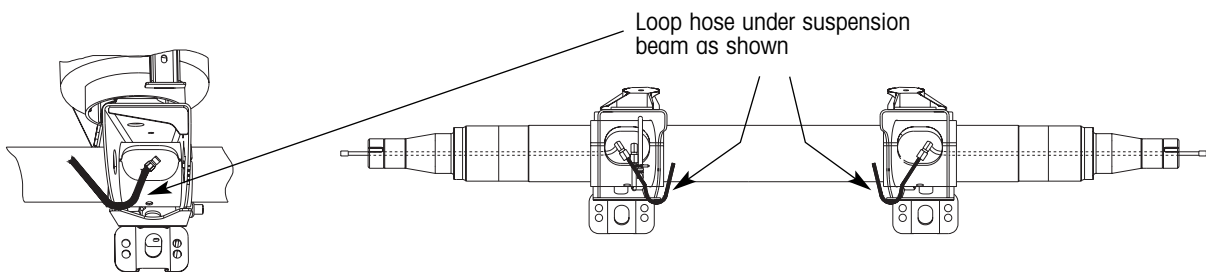

Top Mount, Narrow Bushing Models (HKANT, AANT)

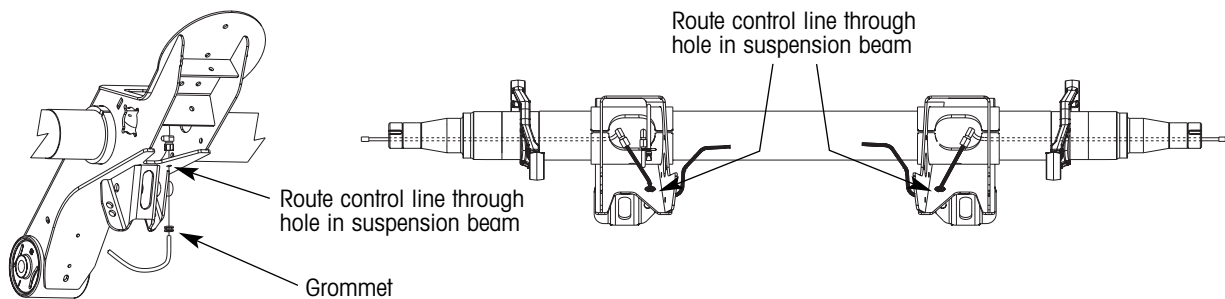

Low Ride, Wide Bushing, Standard Duty (AAL 23K, AAL 25K, AAL 30K); Low Ride, Wide Bushing, Extreme Duty (AAEDL 30K); and Top Mount, Wide Bushing, Extreme Duty (AAEDT 30K) Models

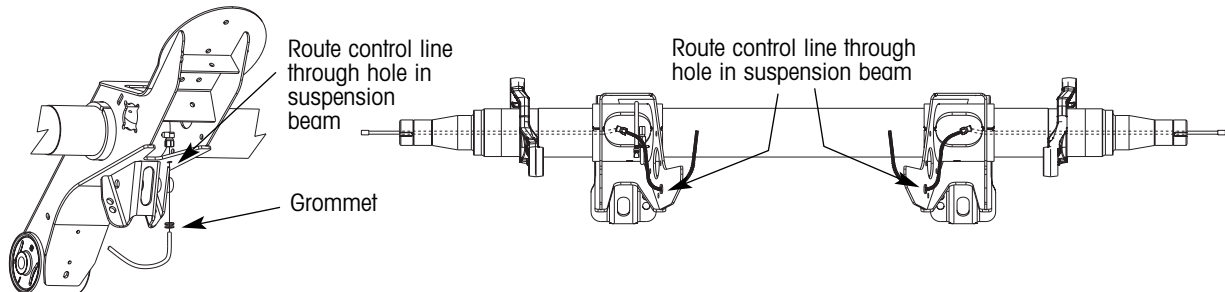

Low Ride, Short Beam, Narrow Bushing Models (AANLS 20K)

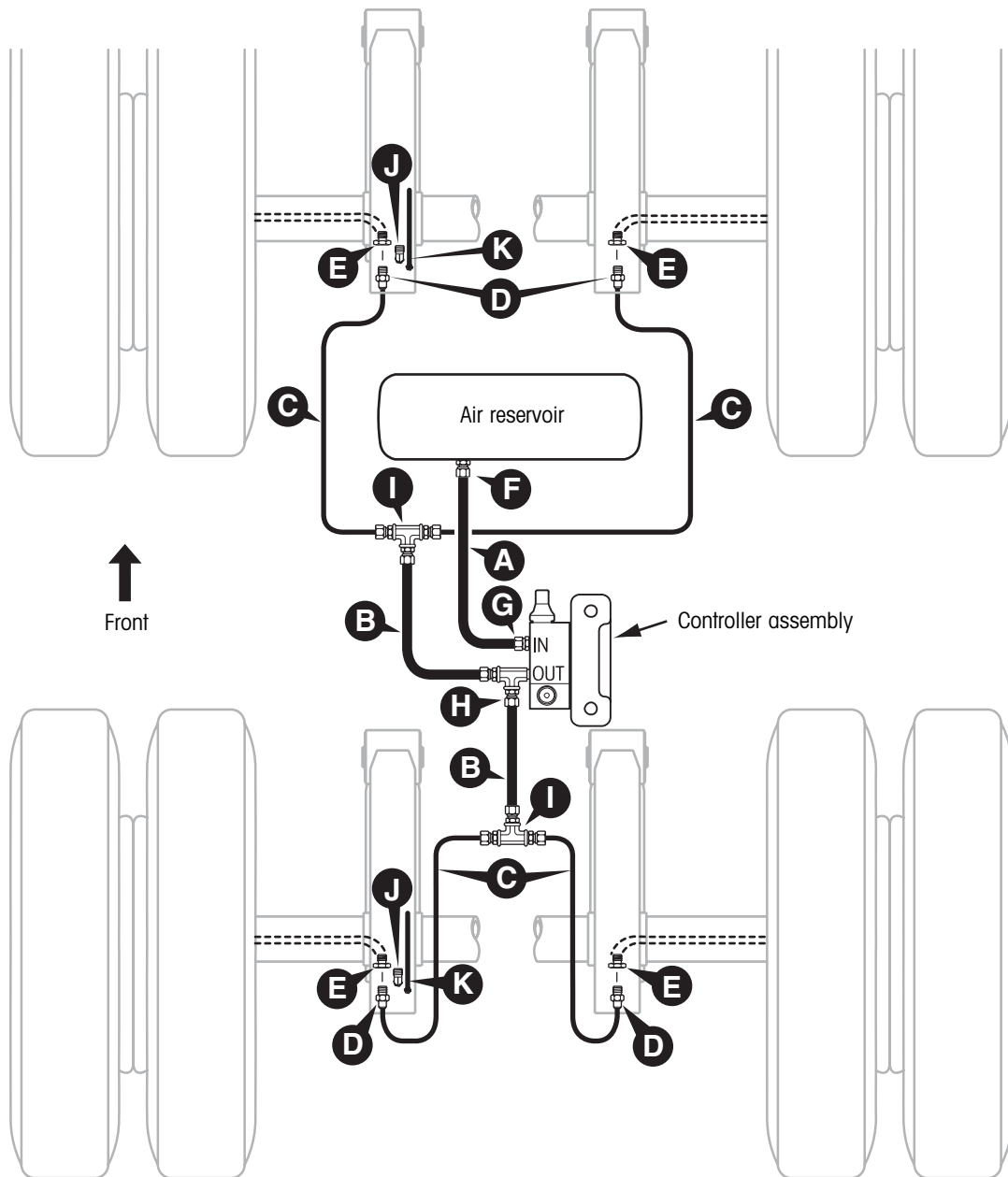

Item

Description

- A** Air line $\frac{3}{8}$ -inch OD nylon air brake tubing; any length
- B** Air line $\frac{3}{8}$ -inch OD nylon air brake tubing; up to eight feet total system length
- C** Air line $\frac{1}{4}$ -inch OD nylon air brake tubing; six to 50 feet total system length
- D** Axle connector 90° elbow, $\frac{1}{8}$ -inch NPT male to $\frac{1}{4}$ -inch NTA
- E** Axle hose fitting $\frac{1}{8}$ -inch NPT female
- F** Supply tank fitting NPT to $\frac{3}{8}$ -inch NTA
- G** Controller IN fitting $\frac{3}{8}$ -inch NPT male to $\frac{3}{8}$ -inch NTA
- H** Controller OUT fitting run tee: $\frac{3}{8}$ -inch NPT male, $\frac{3}{8}$ -inch NTA, $\frac{3}{8}$ -inch NTA
- I** Tee(s) $\frac{3}{8}$ -inch NTA inlet, $\frac{1}{4}$ -inch NTA outlets
- J** Axle vent fitting 90° elbow, $\frac{1}{4}$ -inch NPT male to $\frac{3}{8}$ -inch NTA
- K** Air line $\frac{3}{8}$ -inch OD nylon air brake tubing; one loop around axle with duck bill check valve on end

NTA = nylon tubing adapter

Figure 21. Typical HTIS plumbing schematic — two axles with $\frac{3}{8}$ - and $\frac{1}{4}$ -inch lines

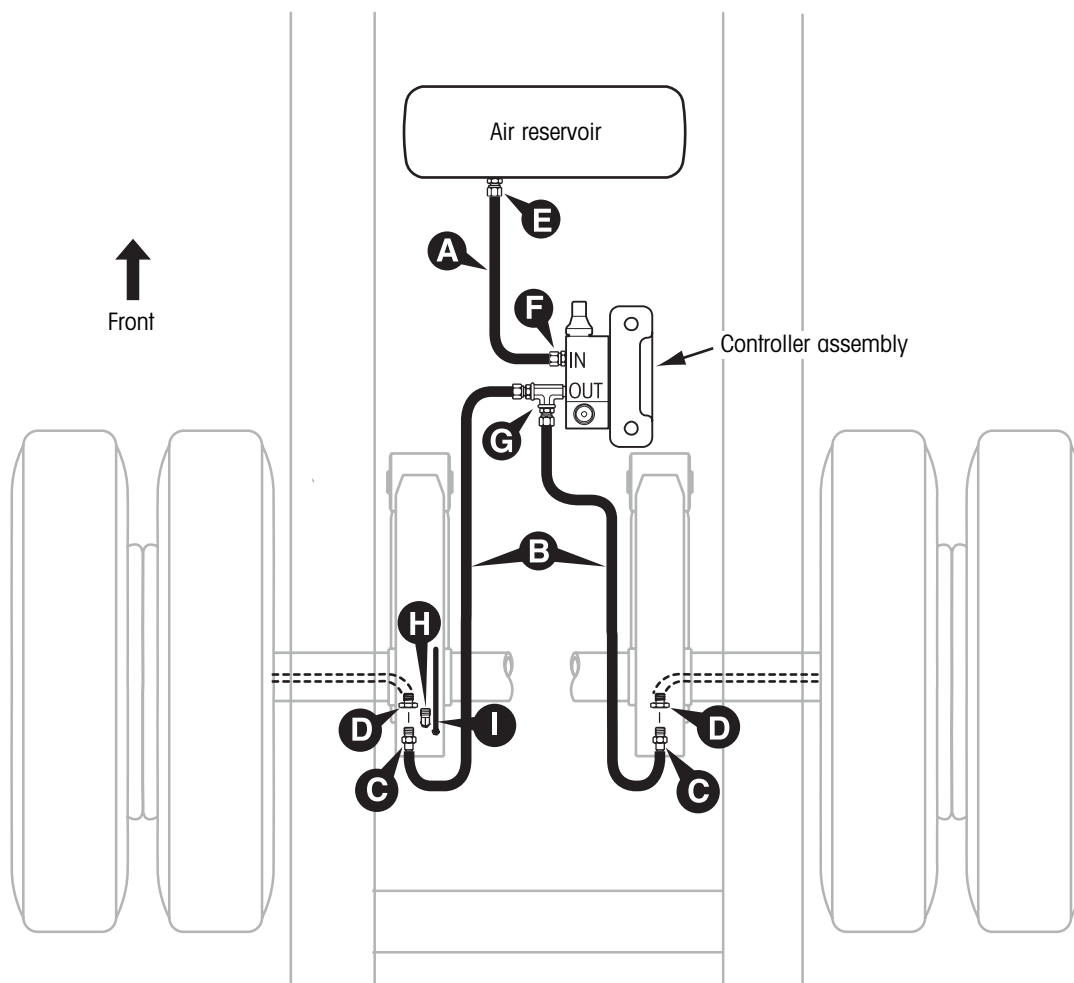

Item	Description
A Air line	$\frac{3}{8}$ -inch OD nylon air brake tubing; any length
B Air line	$\frac{1}{4}$ -inch OD nylon air brake tubing; six to 50 feet total system length
C Axle connector	90° elbow, $\frac{1}{8}$ -inch NPT male to $\frac{1}{4}$ -inch NTA
D Axle hose fitting	$\frac{1}{8}$ -inch NPT female
E Supply tank fitting	NPT to $\frac{3}{8}$ -inch NTA
F Controller IN fitting	$\frac{3}{8}$ -inch NPT male to $\frac{3}{8}$ -inch NTA
G Controller OUT fitting	run tee: $\frac{3}{8}$ -inch NPT male, $\frac{1}{4}$ -inch NTA, $\frac{1}{4}$ -inch NTA (depends on air line B)
H Axle vent fitting	90° elbow, $\frac{1}{4}$ -inch NPT male to $\frac{3}{8}$ -inch NTA
I Air line	$\frac{3}{8}$ -inch OD nylon air brake tubing; one loop around axle with duck bill check valve on end

NTA = nylon tubing adapter

Figure 22. Typical HTIS plumbing schematic — single axle with $\frac{1}{4}$ - or $\frac{3}{8}$ -inch lines

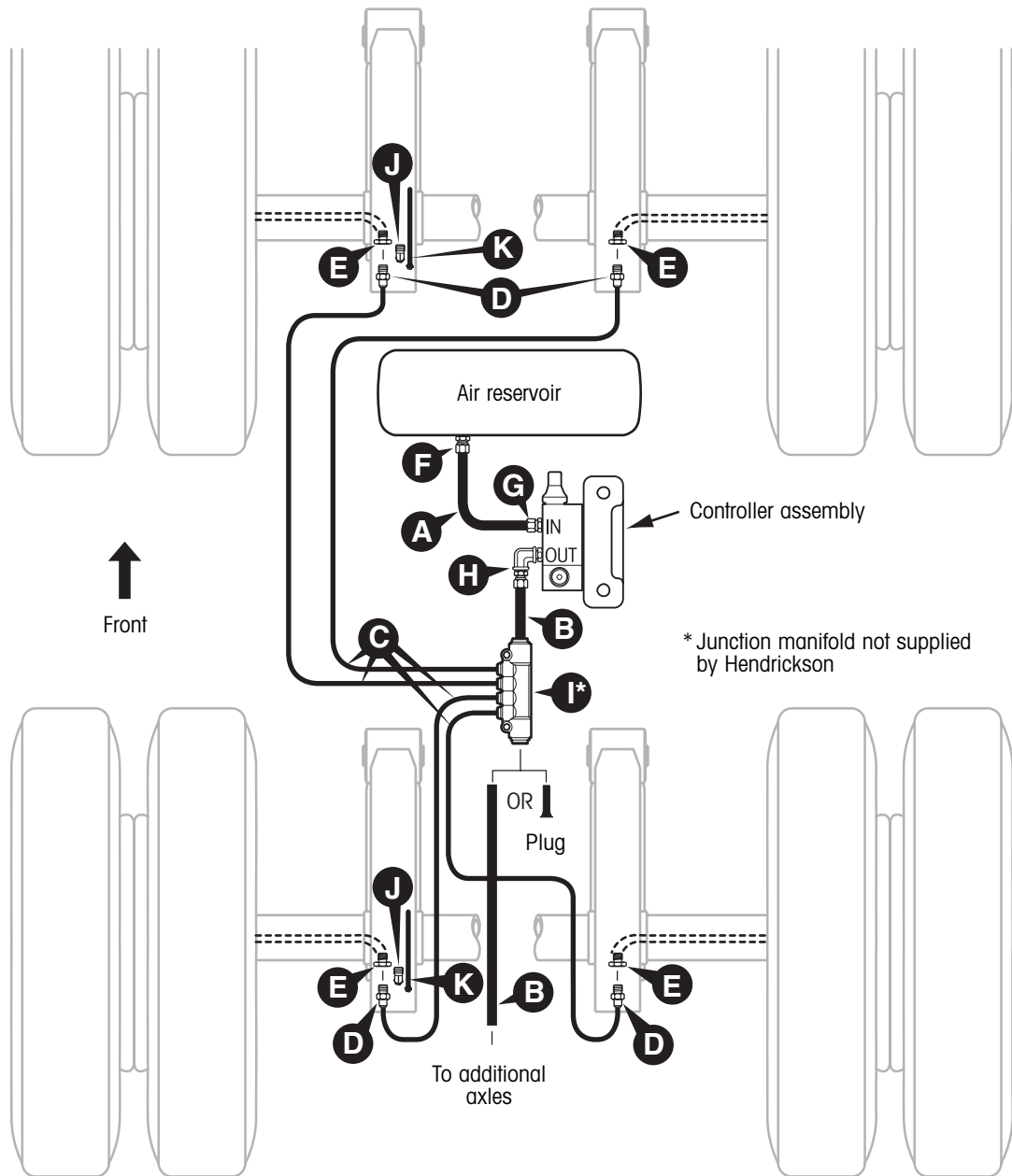

Item	Description	
A	Air line $\frac{3}{8}$ -inch OD nylon air brake tubing; any length	
B	Air line $\frac{3}{8}$ -inch OD nylon air brake tubing; up to eight feet total system length	
C	Air line $\frac{1}{4}$ -inch OD nylon air brake tubing; six to 50 feet total system length	
D	Axle connector 90° elbow, $\frac{1}{8}$ -inch NPT male to $\frac{1}{4}$ -inch NTA	
E	Axle hose fitting $\frac{1}{8}$ -inch NPT female	
F	Supply tank fitting NPT to $\frac{3}{8}$ -inch NTA	NTA = nylon tubing adapter
G	Controller IN fitting $\frac{3}{8}$ -inch NPT male to $\frac{3}{8}$ -inch NTA	
H	Controller OUT fitting $\frac{3}{8}$ -inch NPT male to $\frac{3}{8}$ -inch NTA	
I	Junction manifold* $\frac{3}{8}$ -inch NTA inlet, $\frac{1}{4}$ -inch NTA outlets	*Not supplied by Hendrickson
J	Axle vent fitting 90° elbow, $\frac{1}{4}$ -inch NPT male to $\frac{3}{8}$ -inch NTA	
K	Air line $\frac{3}{8}$ -inch OD nylon air brake tubing; one loop around axle with duck bill check valve on end	

Figure 23. Typical HTIS plumbing schematic — two axles with $\frac{3}{8}$ - and $\frac{1}{4}$ -inch lines and junction manifold



TIRE HOSE INSTALLATION

1. Position the hubcap and wheel so the hoses will not stretch or rub on the wheel. Refer to figure 24 and the table on this page.

⚠ CAUTION: Wheel must be properly “clocked” to the hubcap to prevent the hoses from rubbing on the wheel (figure 24). Failure to do so may result in hose failure.

2. Apply a small amount of thread sealant to the tee fitting swivel threads and screw the tee fitting onto the rotary joint bulkhead adapter. Tighten finger tight then use a wrench to tighten an additional one-quarter turn (figure 24).
3. Attach the tire hose and check valve assemblies to the tee fitting and tighten finger tight.
4. Attach the tire hoses to the tire valve stems and tighten finger tight.

⚠ CAUTION: DO NOT use a wrench or pliers to tighten the tire hose to the valve

stem or tee fitting. Doing so may damage the internal gasket, causing a leak or decreased performance. Both ends of each tire hose must be finger tightened only.

5. Attach the tee fitting guard. Remove the two hub cap bolts closest to the rotary joint bulkhead adapter, place the tee fitting guard over the rotary joint bulkhead adapter as shown in figure 24 and reinstall the hub cap bolts through the holes

Wheel Size	Hole Configuration	Tire Position Clocking
17.5"	2	C
	5	A
19.5"	2	C
	5	B
22.5"	2	C
	5	A
24.5"	2	C
	5	B
Super single 22.5"	N/A	N/A

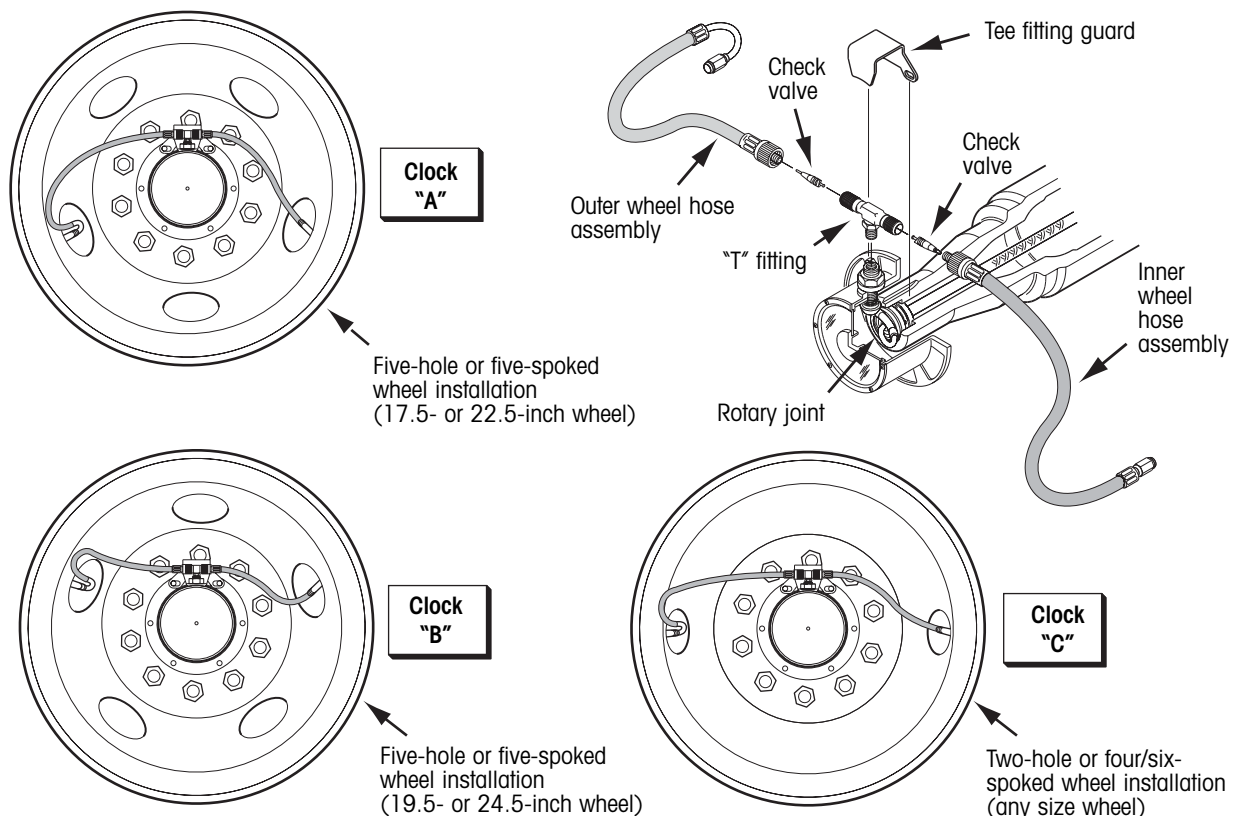

Figure 24. Tee and tire hose installation

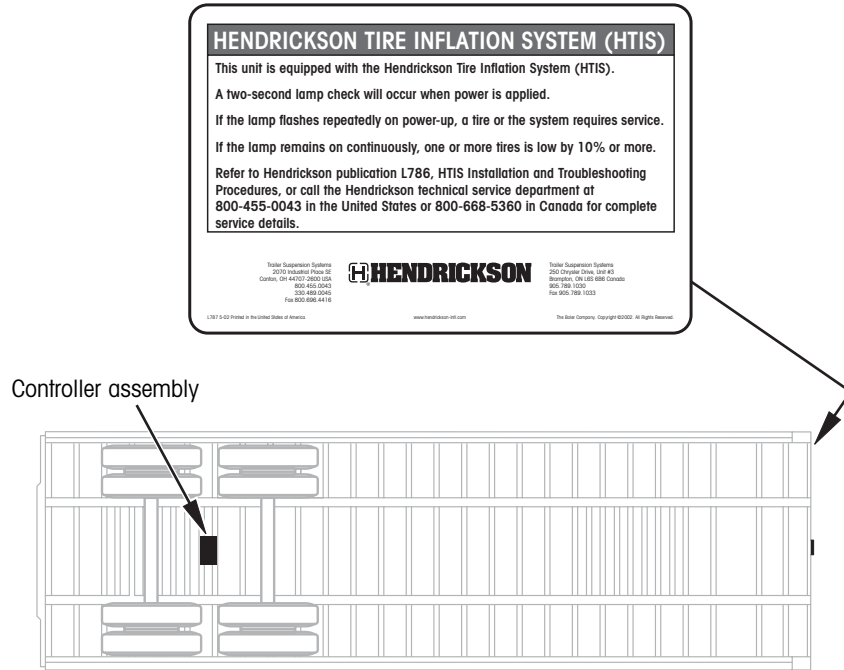

Figure 25. Recommended controller assembly mounting location and label placements

in the tee fitting guard. Tighten to 12-18 ft. lbs. (16-24 N•m) of torque.

NOTE: The tee fitting guard is not used on HUS™ hubs.

LABEL LOCATION

1. Install decal L787 at the front of the trailer near the warning lamp (figure 25).



SYSTEM SETUP

NOTE: Beginning in September of 2003, the controller assembly began shipping with the target inflation pressure already programmed to 95 PSI. These "preprogrammed" controllers are identified with a letter "P" marked on the end of the valve body. With these preprogrammed controllers, no programming is required to enable the HTIS system to function unless a target inflation pressure other than 95 PSI is desired. In that case, refer to the following information for complete controller programming details.

INTRODUCTION

After the installation is complete, the system must be programmed before it is put into service. On power-up, the lamp will remain on as an indication that the target pressure has not yet been programmed.

There are two methods for setting the system's target tire pressure:

System Learn Method: All tire pressures are manually adjusted to the recommended cold tire pressure and the system "reads" this tire pressure.

Service Tool Method: A service tool (PC-based or hand-held) is used to "download" the target pressure over a data link.

SYSTEM LEARN METHOD

To accurately set the target tire pressure using this method, all tires must be at the desired target pressure before beginning this procedure. Refer to the section titled *Manually Checking Tire Pressure* on page six to measure current pressure, then add or remove air (if necessary) until the desired target pressure is reached. Repeat for all tires.

1. Apply 12 volt power to the trailer at the SAE J560 connector.
2. Provide adequate pressure to the brake supply tank (115 psi minimum).
3. Remove the weather cap from the diagnostic connector on the HTIS harness (figure 26). Using a screwdriver, short pins "A" and "E" together three consecutive times for the following

durations: maintain the short for approximately one second, then release the short for approximately one second. The pins to be shorted are easily identified by the slot in the diagnostic connector shell. This slot allows convenient use of a coin or screwdriver tip to short the pins together.

4. Upon entering learn mode, the warning lamp will illuminate for two seconds twice and then will flash once every 10 seconds to acknowledge that the learn mode is active.
5. The system will pressurize the air lines for several seconds, and then will wait for the pressure to stabilize.
6. The current tire pressure will now be stored as the target pressure. Once the target pressure is established, the warning lamp will illuminate for five seconds and then blink the target pressure. For example if the tire pressure is 102 psi; the warning lamp will illuminate for five seconds and then blink one time, pause, blink 10 more times (0 is represented by 10 blinks), pause, and then blink two more times. If the value communicated by the blink codes is lower than the desired target pressure, verify that all the tires are set to the proper pressure and that no line leaks are present.
7. After the system has determined the target pressure, it will remain pressurized for up to two minutes (or until power is cycled). During this time, manually check for air leaks. If an air leak

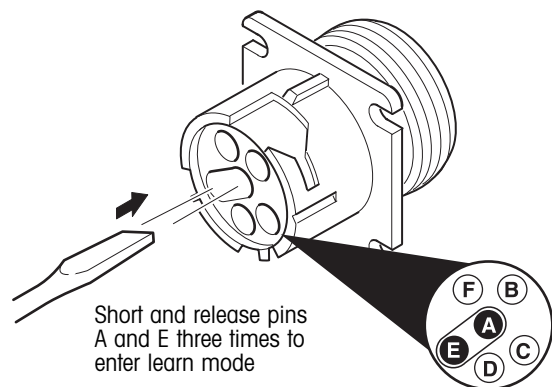

Figure 26. Entering learn mode



Condition	Possible Cause
Lamp does not illuminate during power-up	Poor electrical connection, power below nine volts or burned out lamp
System remains in learn mode	Ensure supply pressure is above 115 psi
The lamp remains illuminated after the learn mode	A fault has occurred. Refer to the blink code diagnostics or use a diagnostic tool
The system reads the tire pressure slightly low	Verify there are no air leaks within the system

is detected, the system will not program a target pressure and the warning lamp will illuminate continuously. If this occurs, correct the leak(s) and then set all tires to the desired target pressure and conduct the learn sequence again.

NOTE: The system is only pressurized during the actual pressure check. A leak will only be audible during the few seconds the system is attempting to determine the target tire pressure.

TROUBLESHOOTING LEARN MODE

Several conditions may prevent the system from "learning" the target pressure. The above table outlines the most common causes of failure.

SERVICE TOOL METHOD

When using a PC or other supported service tool connected to the diagnostic port, follow the instructions included with the service tool.

1. Apply 12 volt power to the trailer at the SAE J560 connector.
2. Using the PC or service tool, enter the desired cold temperature target tire pressure into the ECU. Then remove power from the trailer.
3. Reapply power and verify proper operation by selecting the manual operation mode with the diagnostic tool. Select pressure check and hold to check for air leaks in the system.
4. Watch for a drop in manifold pressure and listen for any audible leaks. If a leak is detected, take corrective actions.
5. If any faults have occurred during programming, clear all historical faults.

TROUBLESHOOTING

TROUBLESHOOTING INTRODUCTION

The system identifies certain conditions and reports them via the trailer mounted warning lamp. In normal mode, the operator is informed whenever a tire is low enough to require service (typically 10%) or there is a fault in the system. For troubleshooting, additional information can be obtained either through blink-codes, or through the use of a service tool connected to the diagnostic connector.

BLINK-CODE DIAGNOSTICS

Blink codes provide a means to determine, without any special tools, what service codes were stored by the system. To activate the blink codes, you must enter the diagnostic mode:

1. Apply power to the system.
2. Remove the weather cap from the diagnostic connector on the HTIS harness (figure 27). Using a screwdriver, short pins "A" and "E" together for approximately five seconds until the warning lamp changes state. The pins to be shorted can be easily identified by the interconnecting slot in

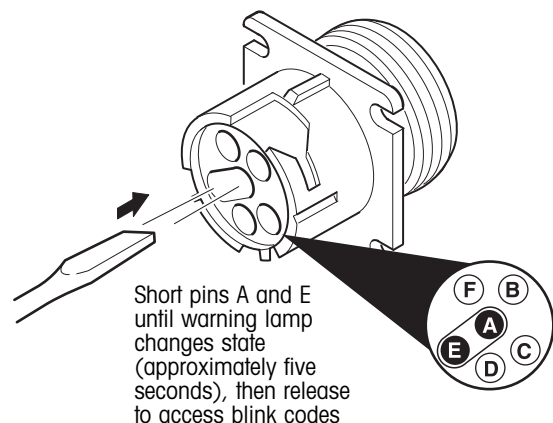

Figure 27. Entering diagnostic mode



the diagnostic connector shell, allowing convenient use of a coin or screwdriver tip to short the pins together. The warning lamp will illuminate for five seconds upon entering the diagnostic mode, and will then flash a two-digit service code. Refer to the table on page 31 for service code descriptions. If more than one service code was stored, there will be a two second pause between each flash sequence. If no service codes are stored or if all the service codes have been flashed, the system will flash a five-five code.

It is not necessary to short pins "A" and "E" on the diagnostic connector when a service tool is used for troubleshooting. Follow the instructions included with the service tool.

BLINK-CODE DESCRIPTION

Low Tire — Low tire pressure is indicated by an illuminated warning lamp (no blinking or flashing). This service code will be stored when one or more tire pressures drops a predetermined amount (typically 10% below the target pressure). Inspect the tires to rule out tire damage. This service code can also be stored as a result of a large line leak.

ECU in Normal Operating Mode	
Warning Lamp Status	System Condition
Two seconds on at power up*	Normal operation (lamp check)
Multiple flashes at power up	Active service code stored in ECU
Continuously on	Low pressure in one or more tires Substantial air line leak Failure to depressurize the system No target tire pressure programmed (new ECU)
<p>NOTE: If the vehicle is powered and the supply air tank pressure is not at a minimum of 90 psi and is not two psi above the target tire pressure, the system will not check or inflate the tires.</p> <p>*The HTIS system utilizes the trailer blue circuit for power. Some early model tractors do not power this circuit, resulting in no power to the system.</p>	

ECU in Learn Mode	
Warning Lamp Status	System Condition
Two seconds on twice when learn mode is selected	Learn mode has been activated
One-half second on every 10 seconds	Inadequate supply pressure to determine target tire pressure
Five seconds on, then multiple one-half second on, two seconds off flashes	A target tire pressure has been determined by the ECU (each series of flashes represents one digit of new target tire pressure. For example; nine flashes, two second pause, five flashes represents a target tire pressure of 95 psig). Zeroes are indicated by 10 flashes.



HTIS INSTALLATION, SERVICE AND TROUBLESHOOTING PROCEDURES

ECU in Diagnostic Mode (Service Codes)*			
1st Digit	2nd Digit	Description	Possible Cause
1	1	Leaking tire**	Repeated attempts to inflate a slow leak in tire or wheel assembly
1	2	Tire pressure low**	Tire pressure more than 10% (typical) below target pressure, significant air line leak
1	4	Line leak	Air line leaking between manifold and wheel-end; very low tire
1	5	Supply pressure low	Supply pressure inadequate to check tire pressures for greater than 24 hours
1	6	Maximum inflate time	System has been inflating for over two hours but has not reached target pressure
1	7	System vent failure	System unable to depressurize air lines. Check valve or manifold contamination
2	1	Target pressure out of range	Programmed target tire pressure is outside allowable range (80 - 125 psig)
4	1	ECU memory failure	Faulty ECU (possible lost data)
4	2	Atmospheric sensor failure	Faulty ECU (system defaults to 14.5 psig reference pressure)
4	3	No target pressure programmed	New installation. Target pressure not yet programmed (applies only to ECU's shipped before September 2003)
5	5	End of service code listing	
6	1	Lamp - open circuit	Faulty lamp or wiring
6	2	Lamp - short circuit	Faulty lamp or wiring
6	3	Solenoid 1 - open circuit	Faulty solenoid 1 or wiring
6	4	Solenoid 1 - short circuit	Faulty solenoid 1 or wiring
6	5	Solenoid 2 - open circuit	Faulty solenoid 2 or wiring
6	6	Solenoid 2 - open circuit	Faulty solenoid 2 or wiring

* The warning lamp will turn on continuously for five seconds when entering the diagnostic mode. The lamp will then flash any active two digit blink codes.

**Following repair of the leaking tire, check all other tires manually for correct tire pressure. If the system has been maintaining pressure in a leaking tire for an extended period of time, the other tires may now be slightly above target pressure.



System Fault — A system fault service code is stored when a problem has been detected with the system. System fault service codes include memory reset, internal atmospheric sensor fault, or other pneumatic faults.

Code Five-Five — This indicates the end of the service code list. If this is the only blink code received, then no service codes were stored.

TROUBLESHOOTING TECHNIQUE

The following technique can be used to help find an air leak (if indications point to an air leak somewhere in the system) or to verify the integrity of all air connections after installation.

1. Disconnect the air OUT line from the manifold assembly.

2. Connect a shop air supply to the air OUT line. **This air supply pressure must be below the programmed target pressure. If necessary, use a regulator to reduce the shop air supply pressure.**

The shop air supply provides a constant source of air pressure to the system, eliminating the 10 minute pressure check intervals provided by the controller assembly. This allows an uninterrupted opportunity to thoroughly check for air leaks.

3. Listen for the hissing sound of an air leak and apply soapy water to all connections or suspected areas. Bubbles in the soapy water will provide a visual indication of an air leak.



SERVICE PROCEDURES WIRING HARNESS REPLACEMENT

REMOVAL

1. Disconnect the five-pin ABS connector.
2. Disconnect the five-pin power supply connector.
3. Disconnect the ECU connector (figure 28).
4. Disconnect the pressure transducer connector.
5. Disconnect the manifold valve connector.
6. Disconnect the warning lamp connector.
7. Unbolt the diagnostic connector from bracket.

INSTALLATION

1. Connect the five-pin ABS connector.
2. Connect the five-pin power supply connector.
3. Connect the ECU connector.
4. Connect the pressure transducer connector.
5. Connect the manifold valve connector.
6. Bolt the diagnostic connector to the bracket.
7. Connect the warning lamp connector.

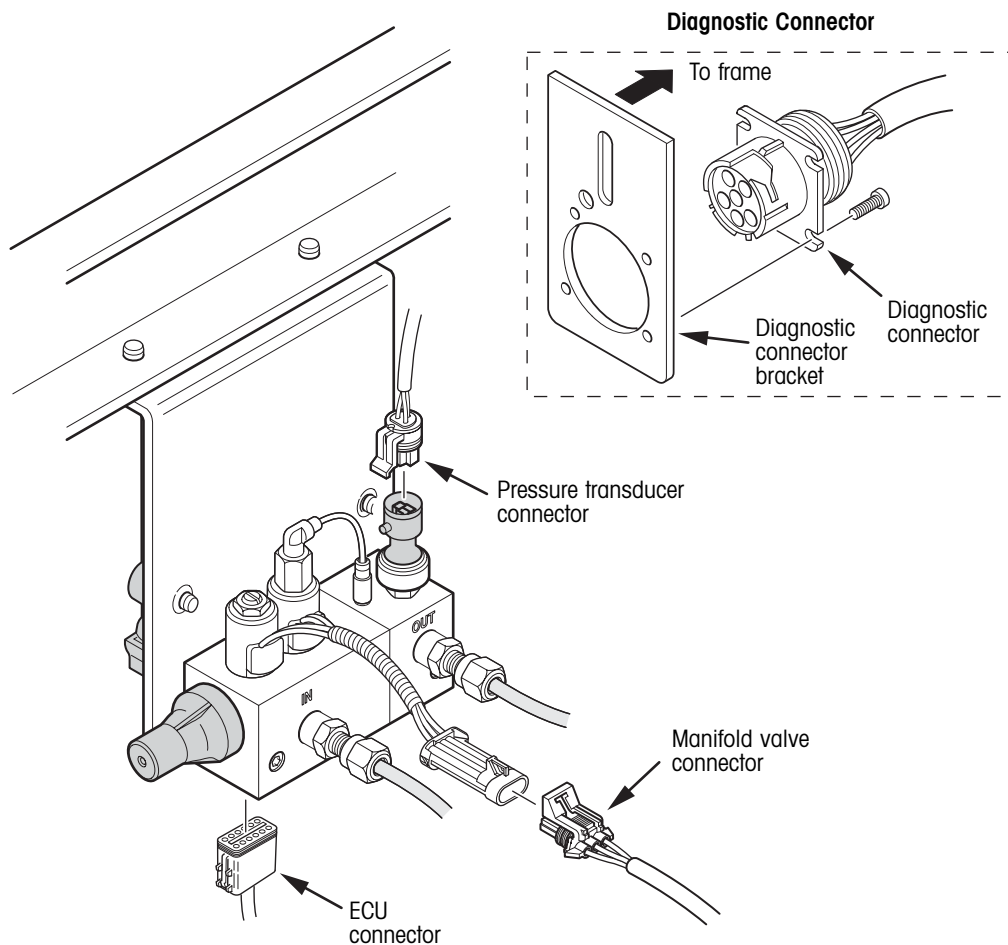

Figure 28. Wiring harness replacement



CONTROLLER ASSEMBLY REPLACEMENT

This procedure replaces the mounting bracket, ECU and manifold as one complete assembly. Note that it is possible to replace the ECU and manifold independently. Refer to the Manifold Replacement and ECU Replacement procedures for complete details.

REMOVAL

1. Exhaust the trailer air tank.
2. Disconnect the pressure transducer connector (figure 29).
3. Disconnect the manifold valve connector.
4. Disconnect the ECU connector.

5. Disconnect the air IN line. Label the line "IN" to avoid confusion when installing the new controller assembly.
6. Disconnect the air OUT line. Label the line "OUT" to avoid confusion when the new controller assembly is installed.
7. If reusing the air line fittings, remove them from the manifold.
8. Remove the two bracket-to-frame mounting bolts.

INSTALLATION

1. Install the two bracket-to-frame mounting bolts.

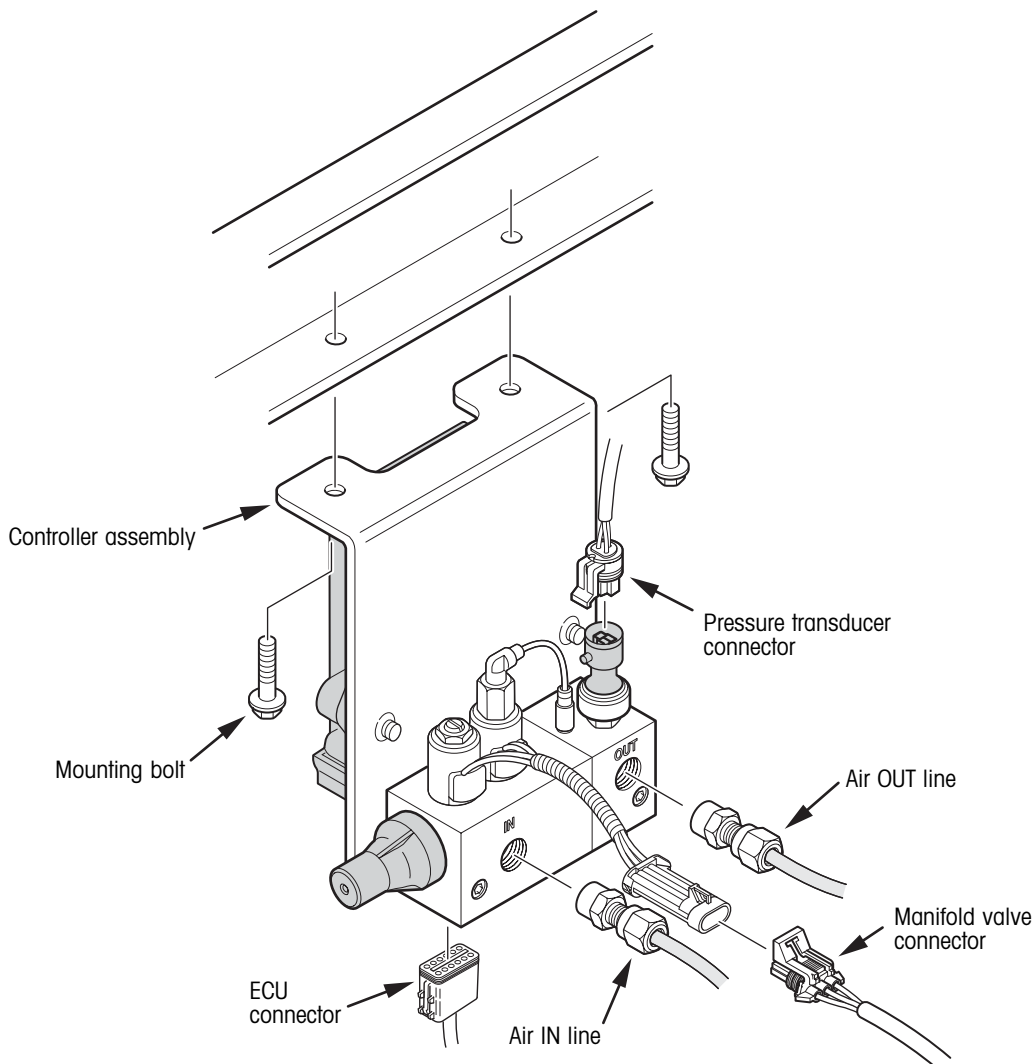

Figure 29. Controller assembly replacement



2. Connect the pressure transducer connector.
3. Connect the manifold valve connector.
4. Connect the ECU connector.
5. If necessary, apply thread sealant to air fittings.
6. Install IN and OUT air line fittings in the manifold.
7. Connect the air IN and air OUT lines to the appropriate ports in the manifold. Test for air leaks by listening or using soapy water.
8. Recharge the trailer air system.
9. Manually measure tire pressure. Refer to the section titled Manually Checking Tire Pressure on page six for complete manual tire pressure measuring instructions.
10. Set target tire pressure. Refer to the System Setup section for complete target pressure setting instructions.



MANIFOLD ASSEMBLY REPLACEMENT

REMOVAL

1. Exhaust the trailer air tank.
2. Disconnect the pressure transducer connector (figure 30).
3. Disconnect the manifold valve connector.
4. Disconnect the air IN line. Label the line "IN" to avoid confusion when installing the new manifold assembly.
5. Disconnect the air OUT line. Label the line "OUT" to avoid confusion when installing the new manifold assembly.
6. Remove the two manifold-to-bracket mounting bolts.
7. With the manifold removed from the trailer, remove the pressure transducer and transfer it to the new manifold.

8. If reusing air line fittings, remove fittings and transfer them to the new manifold.

INSTALLATION

1. Install the two manifold-to-bracket mounting bolts.
2. Connect the pressure transducer connector.
3. Connect the manifold valve connector.
4. If necessary, apply thread sealant to air fittings.
5. Install IN and OUT air line fittings in the manifold.
6. Connect the air IN and air OUT lines to the appropriate ports in the manifold. Test for air leaks by listening or using soapy water.
7. Recharge the trailer air system.
8. Apply power to the trailer (blue circuit on the seven-pin trailer connector).

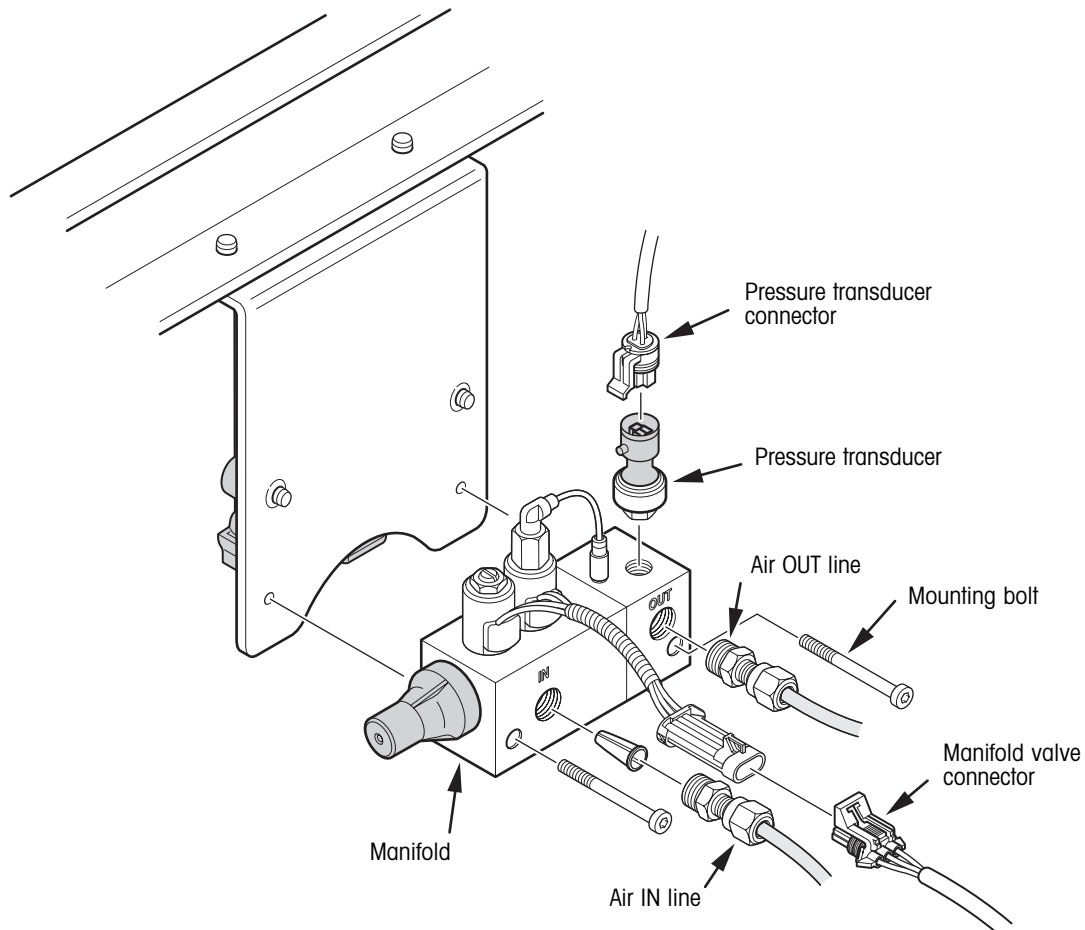

Figure 30. Manifold assembly replacement

MANIFOLD AIR FILTER REPLACEMENT

The system uses an integral air filter (located in the inlet of the controller assembly manifold) to prevent contamination. A contaminated or partially contaminated filter will increase inflation times and reduce the life of the system. A contaminated air filter may also cause the system to store a service code. To reduce the effects of contamination, regular maintenance is required every 12 months or any time the manifold is serviced.

Use the following procedure to replace the air filter:

⚠ WARNING: THE AIR SUPPLY TANK MUST BE EXHAUSTED BEFORE DISCONNECTING THE AIR LINE FROM THE MANIFOLD INLET.

1. Disconnect the air line from the manifold inlet and remove the fitting (figure 31).
2. Use a screwdriver or similar tool to remove the filter from the inlet of the manifold.
3. Inspect the inlet port for contamination and clean as required.
4. Install a new filter into the manifold.
5. Reattach the fittings and air line to the manifold.

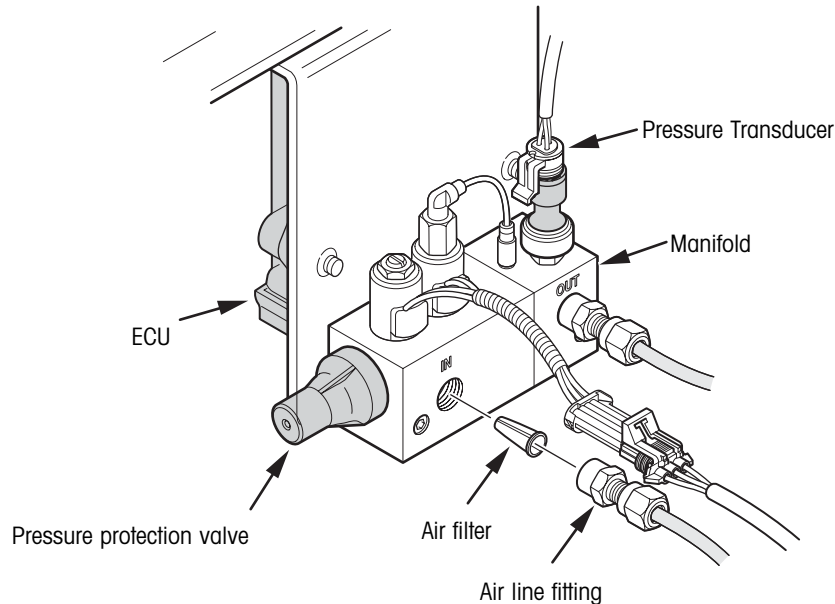

Figure 31. Manifold air filter replacement



ELECTRONIC CONTROL UNIT (ECU) REPLACEMENT

REMOVAL

1. Disconnect trailer from power source.
2. Disconnect the ECU connector (figure 32).
3. Remove the two ECU-to-bracket mounting bolts and remove the ECU.

INSTALLATION

1. Install the replacement ECU and secure with the two ECU-to-bracket mounting bolts.
2. Connect the ECU connector.

3. Manually measure tire pressure on all wheels. Refer to the section titled Manually Checking Tire Pressure on page six for complete manual tire pressure measuring instructions. If necessary, adjust tire pressure to manufacturers recommended settings.
4. Ensure adequate air pressure at trailer (115 psi).
5. Apply power to the trailer (blue circuit on the seven-pin trailer connector).
6. Set target tire pressure. Refer to the System Setup section for complete target pressure setting instructions.

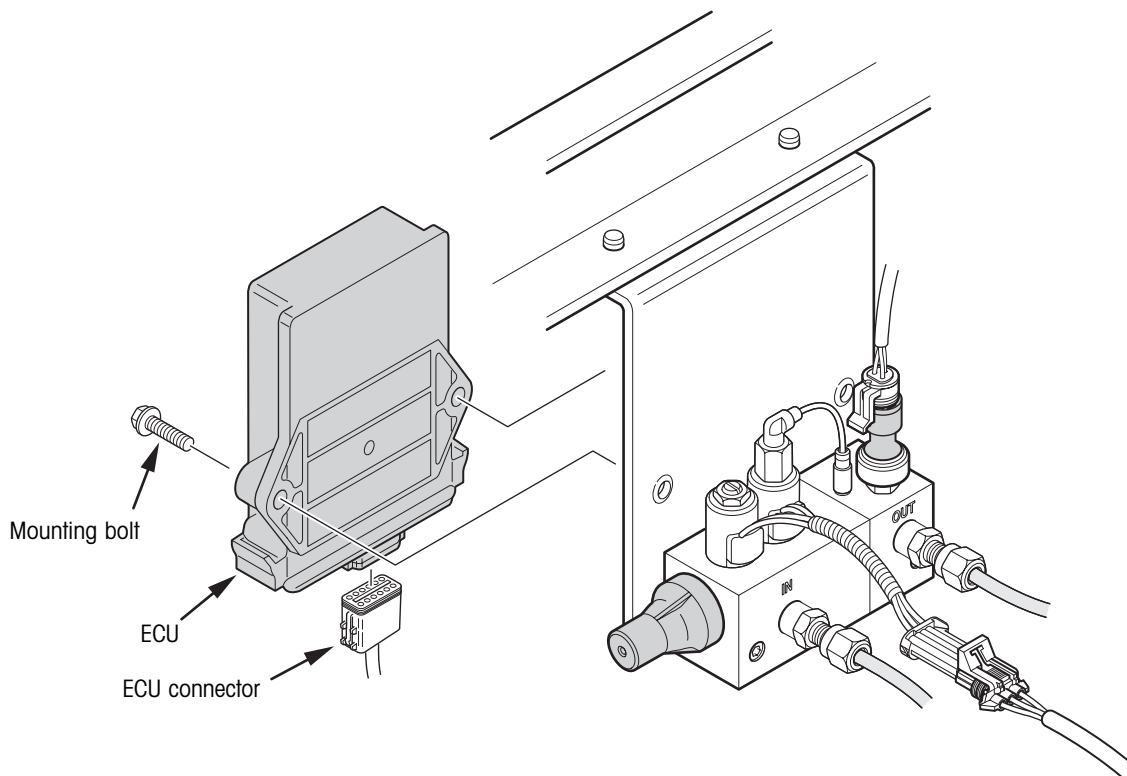

Figure 32. ECU replacement



PRESSURE TRANSDUCER REPLACEMENT

REMOVAL

1. Disconnect trailer from power source.
2. Exhaust the trailer air tank.
3. Disconnect the pressure transducer connector (figure 33).
4. Remove pressure transducer from manifold assembly.

INSTALLATION

1. If necessary, apply thread sealant to the replacement pressure transducer.

IMPORTANT: DO NOT use thread sealant tape. This material may contaminate the air system.

2. Install the replacement pressure transducer in the manifold assembly. Tighten to 10 - 12 ft. lbs. (13 - 16 N•m) of torque.
3. Connect the pressure transducer connector.
4. Ensure adequate air pressure at trailer (115 psi).
5. Apply power to the trailer (blue circuit on the seven-pin trailer connector).
6. Verify warning lamp operation (warning lamp comes on for approximately two seconds when power is applied).

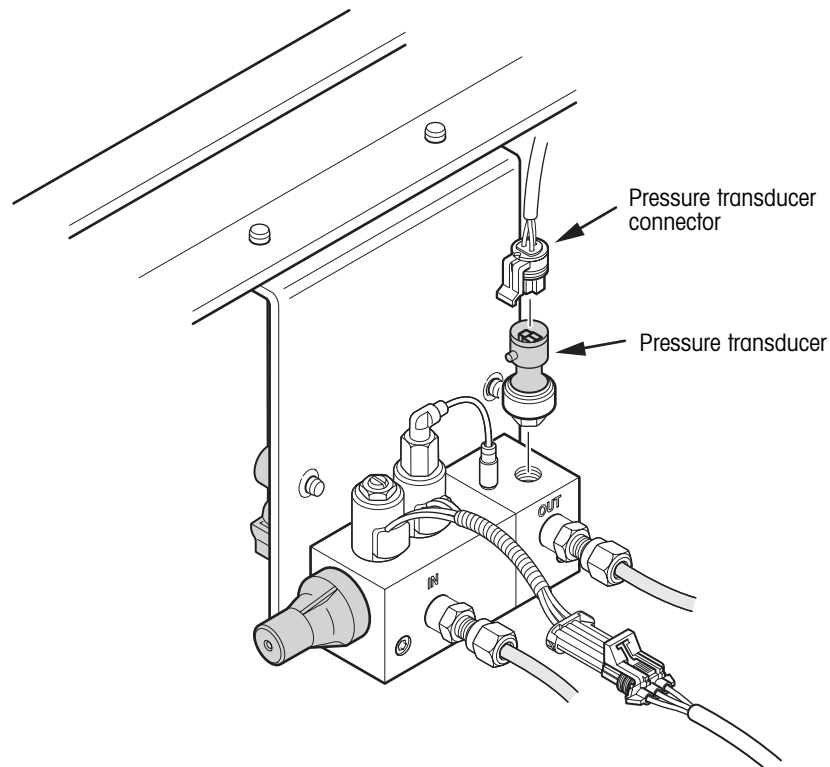

Figure 33. Pressure transducer replacement



WHEEL REMOVAL AND INSTALLATION

Disable the system before wheel removal. This will eliminate potential faults if the system attempts to check tire pressure while the tire hoses are disconnected.

1. Remove the two hub cap bolts that secure the tee fitting guard to the hub and remove the tee fitting guard.
2. Disconnect the tire hoses at the tee on the hubcap (figure 34).

NOTE: There will be no air loss when the tire hose is disconnected at the tee since a check valve is located in the tire hose.

3. Remove the tee from the hubcap fitting. Cover (plug) the hubcap fitting to prevent contamination from entering the system.
4. Observe and record the orientation of the wheel to the hub before removal of the wheel (clock A, B, or C. Refer to figure 34).

5. Remove and reinstall the wheel. Take care not to damage the hubcap fitting. Make sure the wheel is properly oriented to the hub as indicated in figure 34.
6. Reinstall the tee fitting and tighten the inverted flare nut finger tight. Using a wrench, tighten the nut an additional one-quarter turn.
7. Reattach and firmly hand-tighten the tire hoses to the tee. Hand tightening will properly compress the internal rubber gasket for an airtight seal without damaging the gasket.

⚠ CAUTION: DO NOT use a wrench or pliers to tighten the tire hose to the valve stem or tee assembly. Doing so may overtighten the assembly causing the end of the valve stem to cut through the gasket, resulting in an air leak.

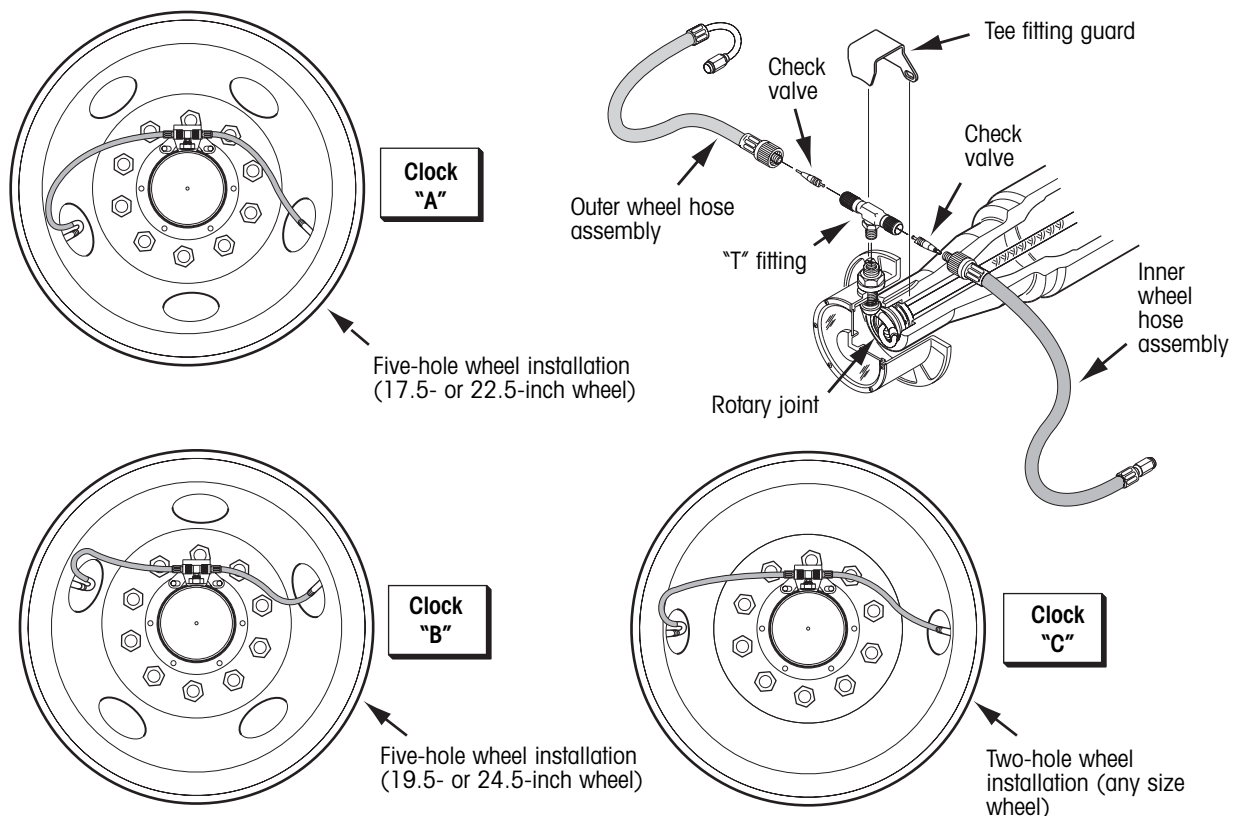

Figure 34. Tire removal and installation



WHEEL-END SERVICE (HUB REMOVAL)

When it is necessary to remove the hub, care must be taken to avoid damaging the rotary joint assembly:

- On HP and HUS™ spindles (axles with same size inner and outer bearings), the hub may be removed with the rotary joint in place. Follow the *Wheel Removal and Installation* procedure on the previous page to remove the wheel. Then remove the jam nut from the rotary joint bulkhead adapter and remove the hubcap. Finally, remove the hub. If necessary, refer to Hendrickson publication L496, *Wheel-End Maintenance Procedures*, for complete hub removal details.
- On HN spindles, the rotary joint must be removed for the hub and bearings to clear the HTIS rotary joint assembly. Follow the *Wheel Removal and Installation* procedure on the previous page to remove the wheel, then use the following procedure:

ROTARY JOINT REMOVAL

1. Remove the jam nut from the rotary joint bulkhead adapter and remove the hubcap (figure 35).

NOTE: The rest of the rotary joint removal procedure depends on rotary joint assembly style. Each style is described as follows:

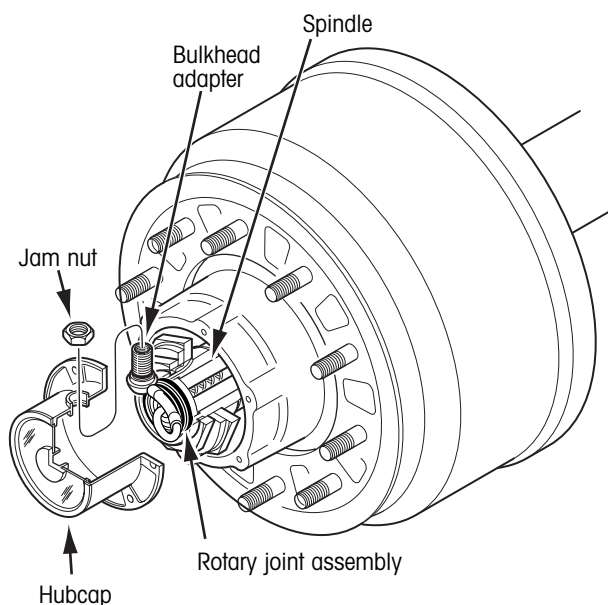

Figure 35. Hubcap to bulkhead adapter removal

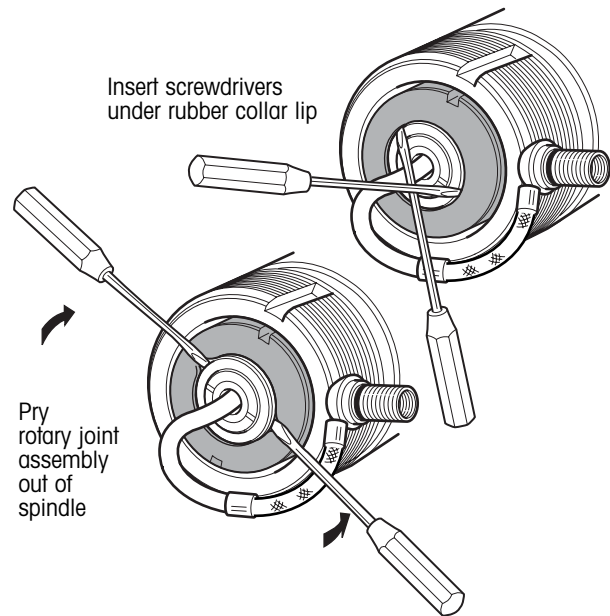

Figure 36. Original style rotary joint removal from spindle

Original Style Rotary Joint Assembly

- a. Place two screwdrivers 180 degrees apart with the blades under the lip of the rubber collar and over the metal lip of the rotary joint body (figure 36).
- b. Push the screwdrivers toward the trailer, prying the rotary joint assembly out of the spindle bore. The rotary joint will then be held in place only by the clamp on the braided hose assembly.
- c. Cut the clamp and remove the rotary joint assembly from the braided hose (figure 37).

Alternate Style Rotary Joint Assembly

- a. Remove the three fasteners holding the rotary joint assembly to the spindle plug (figure 15a).
- b. Cut the clamp and remove the rotary joint assembly from the braided hose.

ROTARY JOINT ASSEMBLY (ORIGINAL STYLE ROTARY UNION ONLY)

1. If necessary, install the rotary joint in the rubber collar. Align the breather notch in the rubber collar with the flat on the rotary joint (figure 38).



INSTALLATION OF ROTARY JOINT ASSEMBLY

1. On one end of the axle, place the stepless ear clamp onto the braided hose assembly sticking out of the spindle (figure 39).
2. Slide the barbed end of the rotary joint assembly into the end of the braided hose assembly until the hose bottoms on the rotary joint body.
3. Using a crimping tool (Oetiker® pliers), squeeze the clamp to tighten the hose to the rotary joint.

NOTE: The rest of the rotary joint installation procedure depends on rotary joint assembly style. Each style is described as follows:

Original Style Rotary Joint Assembly

NOTE: To make installation easier in the next step, apply a small amount of lubricant (grease or oil) to the inside bore of the axle spindle.

⚠ CAUTION: When inserting the rotary joint assembly into the spindle bore in the next step, do not push on the steel air tube. Carefully push only on the face of the rotary joint where it meets the rubber collar (figure 38).

- a. Check the orientation of the breather notch in the rubber collar. Make sure it aligns with the flat on

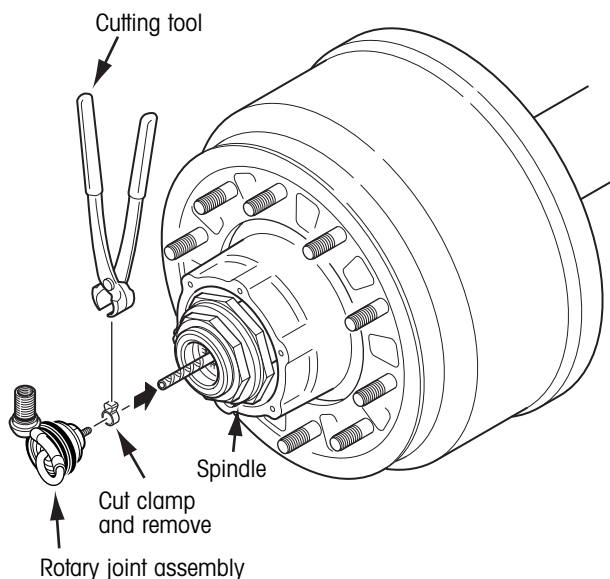

Figure 37. Original style rotary joint assembly removal

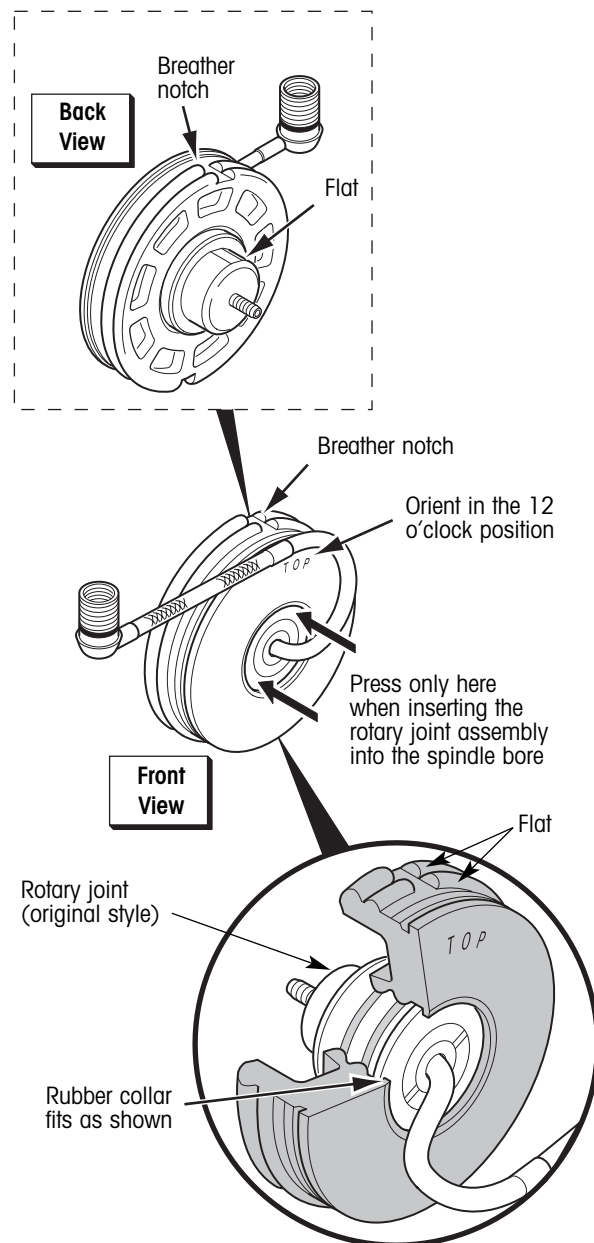

Figure 38. Original style rotary joint assembly

the rotary joint body. Orient the flat on the rotary joint body (located near the clamp) to the 12 o'clock position and press the rotary joint assembly into the spindle bore. The assembly is seated when the outer edge is almost flush with the end of the spindle (figure 38).

- b. Lightly pull on the rotary joint assembly with your fingers to ensure it has been properly inserted into the spindle plug assembly.

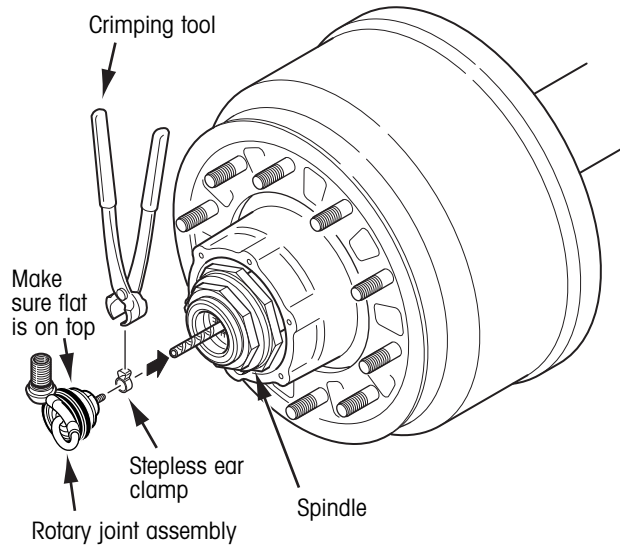

Figure 39. Rotary joint assembly installation

- c. Rotate the rotary joint assembly one full revolution. Make sure that the steel air tube does not contact any part of the spindle or spindle nut system.
- d. Repeat on the other side of the axle.

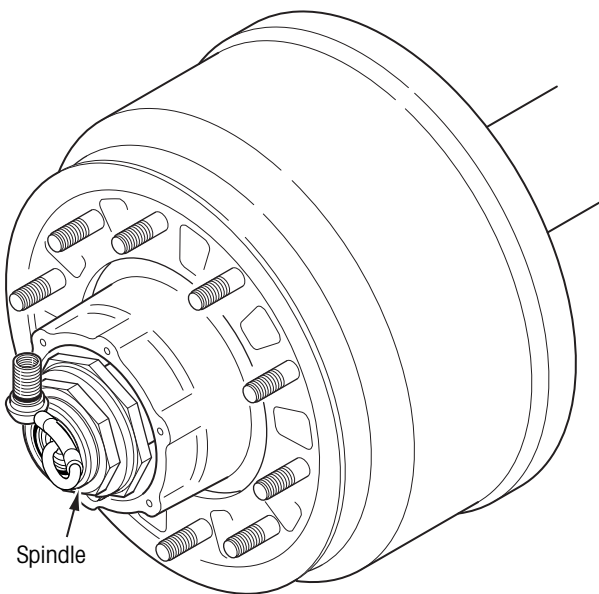

Figure 40. Installed rotary joint assembly

Alternate Style Rotary Joint Assembly

- a. Insert the three fasteners into the rotary joint assembly and fasten to the spindle plug (figure 15a). Tighten the fasteners to 45 ± 5 in. lbs. ($5 \pm \frac{1}{2}$ N•m) of torque.
- b. Rotate the rotary joint assembly one full revolution. Make sure that the steel air tube does not contact any part of the spindle or spindle nut system.
- c. Repeat on the other side of the axle.
- d. Repeat steps one through six on the other side of the axle.

HUBCAP ASSEMBLY

- 1. Place hubcap gasket over rotary joint exit tube and bulkhead adapter.
- 2. Lubricate O-ring on the rotary joint bulkhead adapter.
- 3. From the inside, insert the bulkhead adapter through the hole labeled "Air" in the hubcap. Attach the jam nut and hand tighten (figure 41).

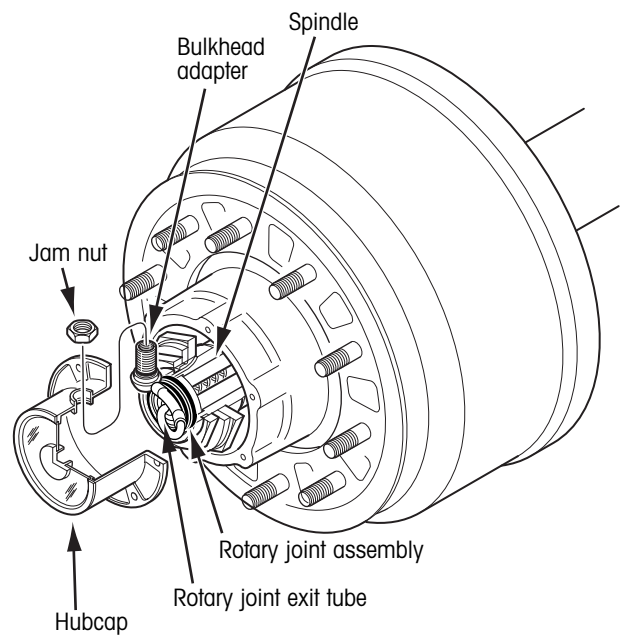

Figure 41. Hubcap to bulkhead adapter assembly



⚠ CAUTION: Wheel must be properly “clocked” to the hubcap to prevent the hoses from rubbing on the wheel (figure 24). Failure to properly “clock” the wheels may result in hose failure.

4. Install the hubcap. If the hubcap is a screw-on style used on the HUS hub, tighten it to 50-100 ft. lbs. (68-137 N•m) of torque. If the hubcap is a bolt-on style used on the other hubs, tighten the hubcap bolts to 12-18 ft. lbs. (16-24 N•m) of torque.
5. Tighten the rotary joint jam nut to 15 ft. lbs. (20 N•m) of torque.
6. Refer to the *Tire Hose Installation* section on page 26 to complete the reassembly.

GLOSSARY

Hendrickson Tire Inflation System (HTIS) — A system that maintains the pressure of selected tires and activates a warning to alert the vehicle operator if the pressure drops by more than 10%.

Manifold — Receives signals from the Electronic Control Unit (ECU) and directs air flow to either maintain or inflate the tires to keep them at their target pressure. Uses a pressure protection valve to ensure supply pressure stays above 80 psi.

Electronic Control Unit (ECU) — The ECU is programmed with the target tire pressure and directs the manifold to supply air to the tires when needed. A significant drop in tire pressure causes the ECU to illuminate the warning lamp.

Rotary Joint — Rotary air seal assembly that allows air transfer from wheel end to tire(s) while vehicle is in motion. The rotary joint is only pressurized while the system is checking tire pressure or inflating.

Target Tire Pressure — The desired cold temperature tire pressure.



APPENDIX

TARGET PRESSURE: 100 PSI

	-40	-30	-20	-10	0	10	20	30	40	50	60	70	80	90	100	110	120	
Ambient temperature when tire pressure is measured	-40	100	97	-95	92	90	88	86	84	82	80	78	76	74	73	71	70	68
	-30	103	100	97	95	93	90	88	86	84	82	80	78	77	75	73	72	70
	-20	105	103	100	97	95	93	90	88	86	84	82	81	79	77	75	74	72
	-10	108	105	103	100	98	95	93	91	89	86	85	83	81	79	77	76	74
	0	111	108	105	103	100	98	95	93	91	89	87	85	83	81	79	78	76
	10	114	111	108	105	102	100	98	95	93	91	89	87	85	83	82	80	78
	20	116	113	110	108	105	102	100	98	95	93	91	89	87	85	84	82	80
	30	119	116	113	110	107	105	102	100	98	95	93	91	89	87	86	84	82
	40	122	119	116	113	110	107	105	102	100	98	96	94	91	90	88	86	84
	50	125	121	118	115	112	110	107	105	102	100	98	96	94	92	90	88	86
	60	127	124	121	118	115	112	110	107	105	102	100	98	96	94	92	90	88
	70	130	127	123	120	117	115	112	109	107	105	102	100	98	96	94	92	90
	80	133	129	126	123	120	117	114	112	109	107	104	102	100	98	96	94	92
90	136	132	129	126	122	120	117	114	111	109	107	104	102	100	98	96	94	
100	138	135	131	128	125	122	119	116	114	111	109	106	104	102	100	98	96	
110	141	137	134	131	127	124	122	119	116	114	111	109	106	104	102	100	98	
120	144	140	137	133	130	127	124	121	118	116	113	111	109	106	104	102	100	

Ambient temperature when the target tire pressure is set

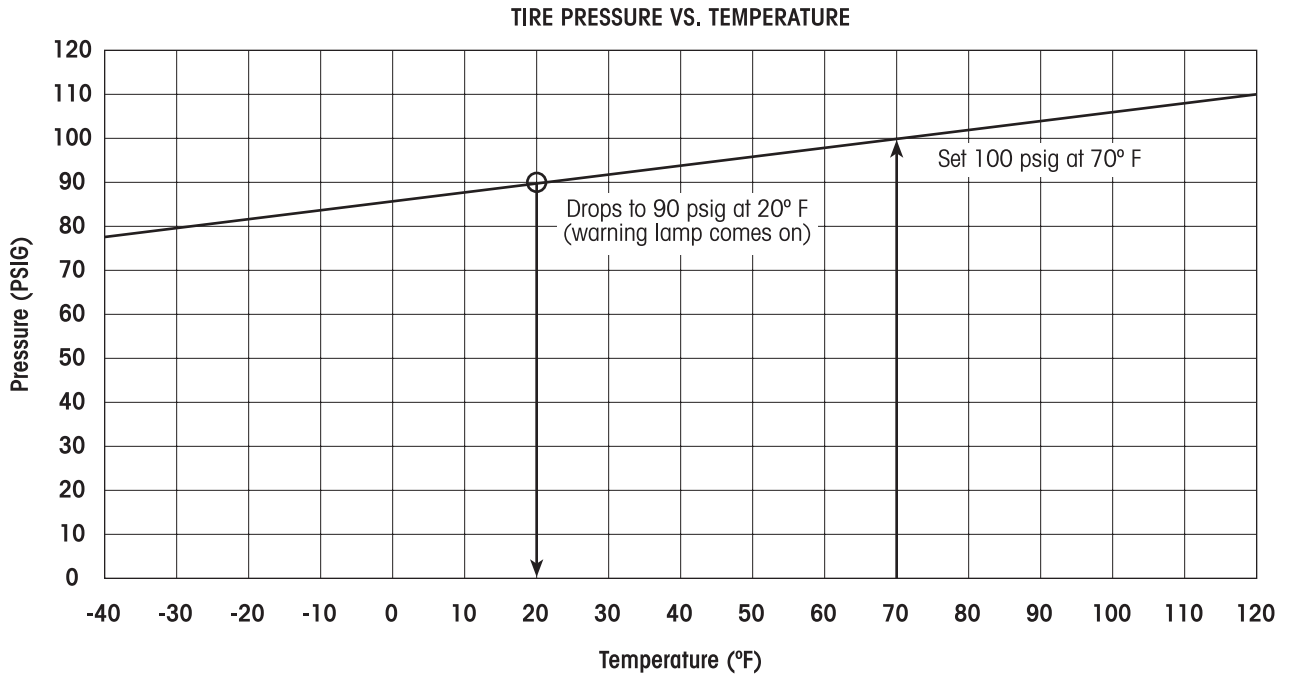

Figure 42. Typical tire maintenance system performance at 100 psig



Typical Trailer Schematic

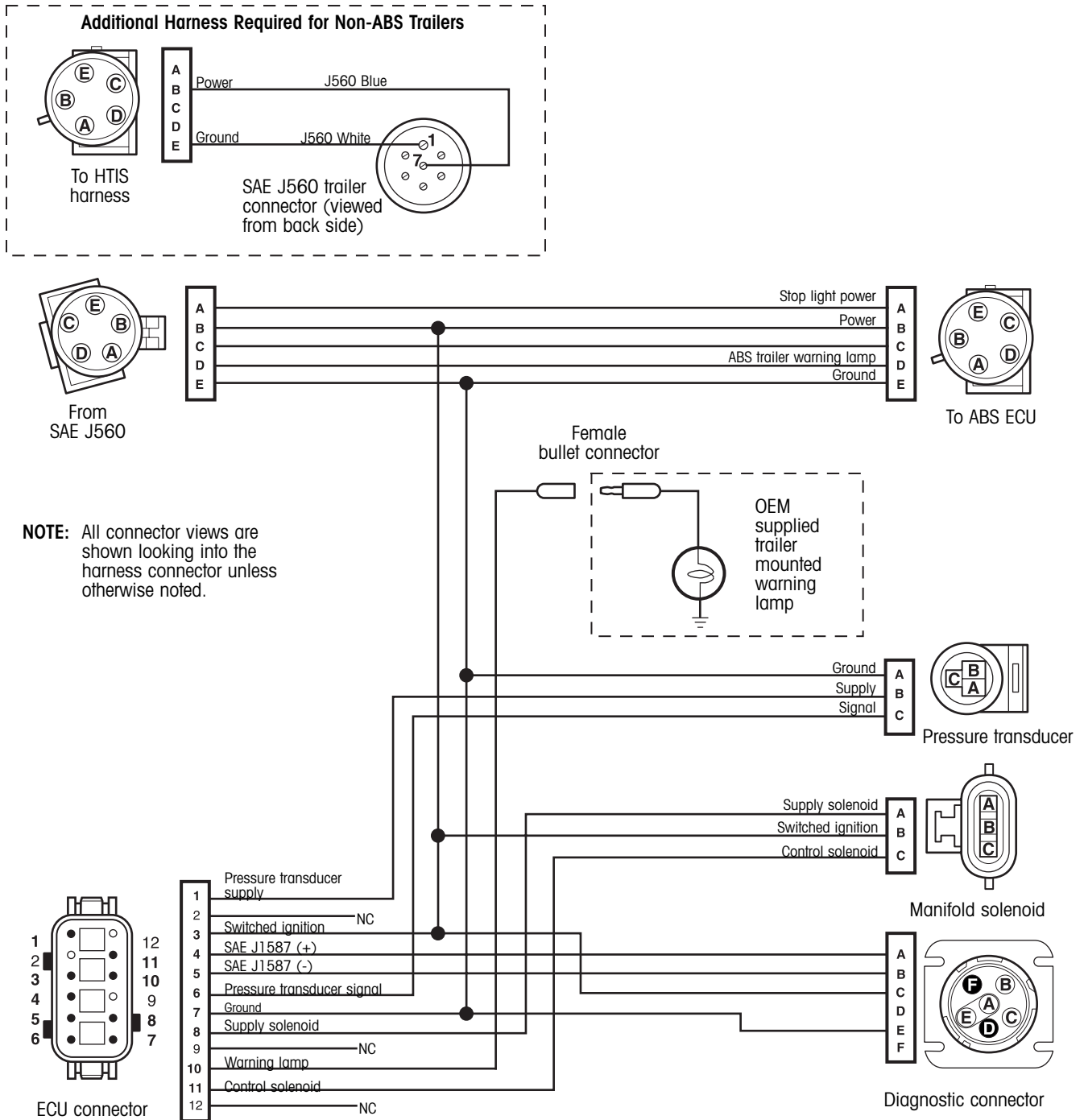

Figure 43. Tire maintenance system schematic





Information contained in this literature was accurate at the time of publication. Product changes may have been made after the copyright date that are not reflected.

Trailer Suspension Systems
2070 Industrial Place SE
Canton, OH 44707-2600 USA

866.RIDEAIR (866.743.3247)
330-489-0045
Fax 800.696.4416

www.hendrickson-intl.com

Trailer Suspension Systems
250 Chrysler Drive, Unit #3
Brampton, ON L6S 6B6 Canada

905.789.1030
Fax 905.789.1033

The Boler Company.
Copyright © 2003
All Rights Reserved