

TECHNICAL BULLETIN

INTRAAX® AAL WITH LDA™ HEIGHT CONTROL VALVE KITS

SUBJECT: Change in HCV
lower mounting bracket

LIT NO: T89006

DATE: February 2016

Hendrickson has identified that some AAL suspensions and HKARL sliders equipped with air-disc brakes may have potential contact with certain Height Control Valve (HCV) kits.

Effective February 29, 2016 the lower Height Control Valve (HCV) mounting bracket has been modified to provide an optimized solution for all suspensions.

As shown below, the mounting remains the same. However, the shape of the bracket has been modified for greater clearance.

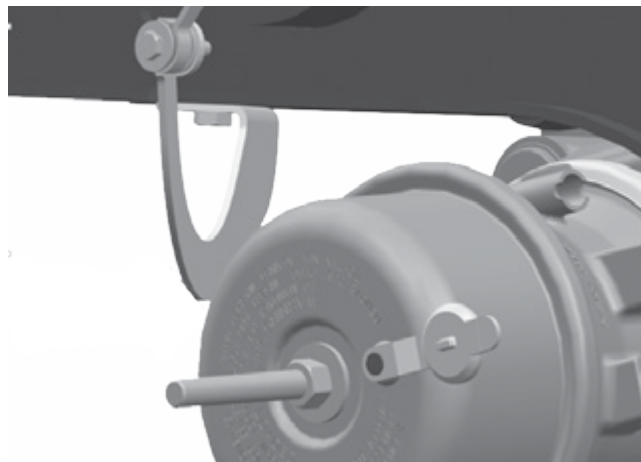

HCV lower linkage assembly with previous bracket

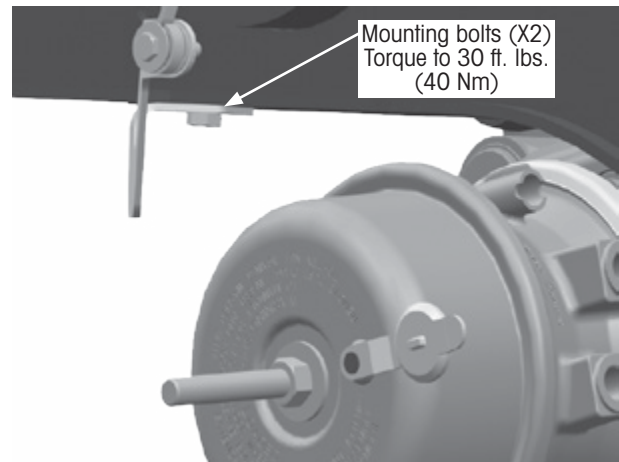

HCV lower linkage assembly with new bracket

AAL Large Diameter Axle (LDA) suspensions and HKARL sliders equipped with air-disc brakes and fitted with a HCV kit manufactured between January 2013 and February 2016 should be inspected for a potential contact between the current lower HCV bracket and roadside brake chamber.

Any parts exhibiting any such contact should be reported to **Hendrickson Trailer Technical Services** in the United States at **866-RIDEAIR (743-3247)** or e-mail **HTTS@Hendrickson-intl.com**.

For details on HCV assembly, refer to Hendrickson literature number L668 available at:

www.Hendrickson-intl.com/TrailerLit.

Call Hendrickson at **866.RIDEAIR (743.3247)** for additional information.

 **HENDRICKSON**

www.hendrickson-intl.com

TRAILER COMMERCIAL VEHICLE SYSTEMS

2070 Industrial Place SE
Canton, OH 44707-2641 USA
866.RIDEAIR (743.3247)
330.489.0045 • Fax 800.696.4416

Hendrickson Canada

250 Chrysler Drive, Unit #3
Brampton, ON Canada L6S 6B6
800.668.5360
905.789.1030 • Fax 905.789.1033

Hendrickson Mexicana

Circuito El Marqués Sur #29
Parque Industrial El Marqués
Pob. El Colorado, Municipio El Marqués,
Querétaro, México C.P. 76246
+52 (442) 296.3600 • Fax +52 (442) 296.3601