

H PARTS LIST

HT190T TOP MOUNT

LIT NO: L936

DATE: June 2019

REVISION: A



HT190T TOP-MOUNT PARTS LIST



Picture shown may not resemble all models.

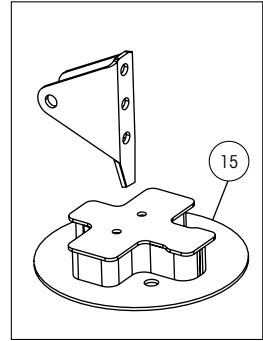
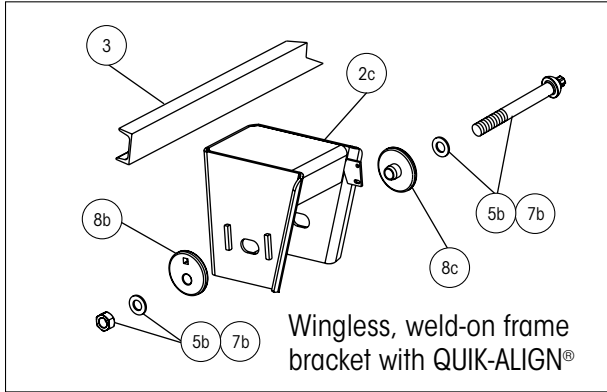

Winged, weld-on frame bracket with QUIK-ALIGN

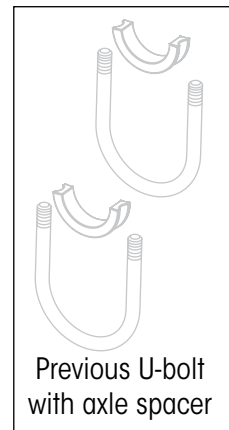
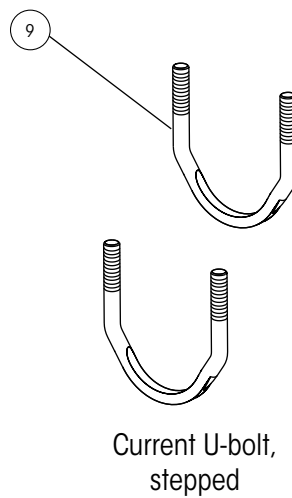
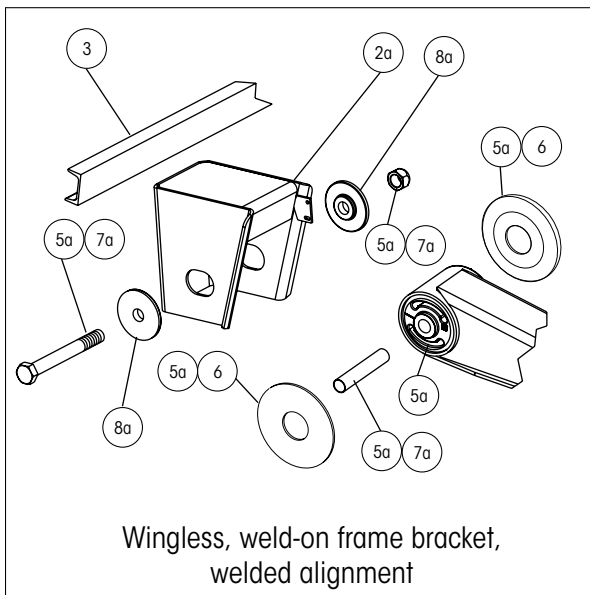
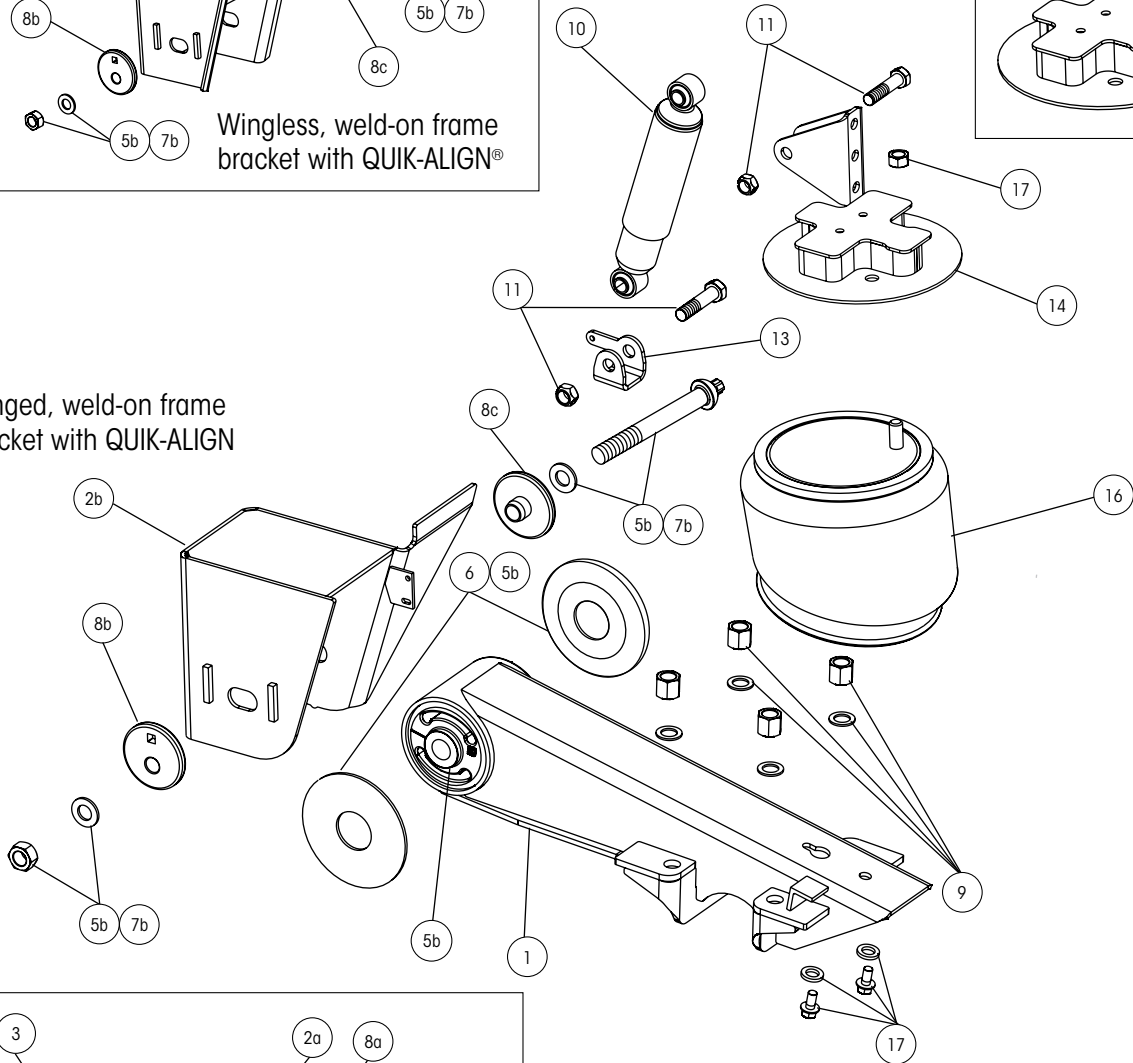



HT190T TOP-MOUNT PARTS LIST

ITEM	DESCRIPTION	PART NO.	QTY. PER SUSP.	FITS MODELS HT190 ? or N-HT190 ?		
1	BEAM ASSEMBLY¹					
	Roadside	S-20000-1	1	All models		
	Curbside	S-20000-2	1	All models		
2	FRAME BRACKET					
	2a Wingless, Weld-on Welded Alignment					
	Roadside	S-20064-1	1	T-14-001	T-14-002	T-14-005
	Curbside	S-20064-2	1	T-14-009	T-15-001	T-15-002
				T-15-005	T-15-009	T-15-020
	Roadside	S-20065-1	1	T-16-001	T-16-002	T-16-003
	Curbside	S-20065-2	1	T-16-005	T-16-009	T-17-001
				T-17-002	T-17-005	T-17-009
	2b Winged, Weld-on QUIK-ALIGN®					
	Roadside	S-21179-1	1	TA14-001	TA14-005	TA15-005
	Curbside	S-21179-2	1			
	Roadside	S-21165-1	1	TA16-005	TA17-005	
	Curbside	S-21165-2	1			
	2c Wingless, Weld-on QUIK-ALIGN					
	Roadside	S-21590-1	1	TB14-001	TB14-005	TB14-024
	Curbside	S-21590-2	1	TB15-001	TB15-002	TB15-005
				TB15-024		
	Roadside	S-21592-1	1	TB16-001	TB16-005	TB17-005
	Curbside	S-21592-2	1			
3	FRAME BRACKET C-CHANNEL	A-1631-19	1	All models		
4	FRAME BRACKET GUSSET (Not Shown)	S-27330	2	TA14-005	TA15-005	TA16-005
				TA17-005		
5	TRI-FUNCTIONAL® II BUSHING KIT²					
	5a Welded Alignment	S-6914	2	Includes bushing, bushing tube spacers, cap screw, prevailing torque hex nut, liner and lube		
	5b QUIK-ALIGN	S-24691	2	Includes bushing, bushing tube spacers, round head bolt, prevailing torque hex nut, hardened washers and lube		
6	BUSHING TUBE SPACER	S-21099	4	All models		
7	PIVOT BOLT KIT					
	7a Welded Alignment	S-3646	2	Includes cap screw, prevailing torque hex nut and liner		
	7b QUIK-ALIGN	S-24679	2	Includes round head bolt, hardened washers and prevailing torque hex nut		
8	ALIGNMENT COLLAR					
	8a Welded Alignment	S-2770	4	Collars are welded to frame bracket		
	8b Eccentric, QUIK-ALIGN (outer)	S-20925	2	Alignment hole is off center		
	8c Concentric, QUIK-ALIGN (inner)	S-20924	2	Alignment hole is centered		
9	U-BOLT KIT	S-21140/4	4	Includes (1) stepped U-bolt and hardware Axle spacer is not needed with stepped U-bolt		

¹Lower shock clevis (item #12) is included with beam assembly.

²Bushing tool S-21307 is required to correctly re-bush the suspension.

NOTE: Identification tag can be found on the front of the roadside frame bracket or the inside of the curbside beam.

HT190T TOP-MOUNT PARTS LIST



ITEM	DESCRIPTION	PART NO.	QTY. PER SUSP.	FITS MODELS HT190 ? or N-HT190 ?
10	SHOCK ABSORBER	S-20001	2	All models
11	SHOCK BOLT KIT	S-20031/2	2	T-14-005 T-15-005 T-16-005 T-17-005 TA14-005 TA15-005 TA16-005 TA17-005 TB14-005 TB14-024 TB15-005 TB15-024 TB16-005 TB17-005
		S-20218/2	2	T-14-001 T-14-002 T-14-009 T-15-001 T-15-002 T-15-009 T-15-020 T-16-001 T-16-002 T-16-003 T-16-009 T-17-001 T-17-002 T-17-009 TA14-001 TB14-001 TB15-001 TB15-002 TB16-001
12	SHOCK STRAP KIT (Not Shown)	S-14587-1	1	Includes (4) nylon ties and (2) shock straps. Use with S-20001 shocks.
13	LOWER SHOCK CLEVIS ³	S-20069	2	All models
14	AIR SPRING SHOCK MOUNT ⁴			
	Roadside	C-20011-1	1	T-14-005 TA14-005 TB14-005
	Curbside	C-20011-2	1	TB14-024
	Roadside	C-20012-1	1	T-15-005 TA15-005 TB15-005
	Curbside	C-20012-2	1	TB15-024
	Roadside	C-20013-1	1	T-16-003 T-16-005 TA16-005
	Curbside	C-20013-2	1	TB16-005
	Roadside	C-20014-1	1	T-17-005 TA17-005 TB17-005
	Curbside	C-20014-2	1	
15	AIR SPRING SPACER ASSEMBLY ⁴			Includes air spring plate and assembly
		C-20016-1	2	T-15-001 T-15-002 T-15-009 TB15-002
		C-20016-2	2	T-16-001 T-16-002 TB16-001 TB16-009
		C-20016-3	2	T-17-001 T-17-002 T-17-009
16	AIR SPRING	S-20223	2	All models
17	AIR SPRING MOUNTING KIT	S-20033/2	2	All models
18	UNIVERSAL HEIGHT CONTROL VALVE (Not Shown)	VS-227	1 ⁵	Fits all models. Includes height control valve, exhaust line and spacer bracket.
19	UNIVERSAL LINKAGE ASSEMBLY (Not Shown)	S-14187	1 ⁵	Includes linkage assembly and hardware
20	AUTO DUMP VALVE (Not Shown)	VS-23460	1 ⁵	Includes dump valve and fittings
21	PRESSURE PROTECTION VALVE (Not Shown)	VS-1128	1 ⁵	Includes valve only

³ Lower shock clevis is included with beam assembly (item #1).

⁴ Component may vary for slider suspensions based on slider box manufacturer. Contact Hendrickson for assistance.

⁵ Quantities for air control components are per trailer.

NOTE: Identification tag can be found on the front of the roadside frame bracket or the inside of the curbside beam.

Actual product performance may vary depending upon vehicle configuration, operation, service and other factors.

All applications must comply with applicable Hendrickson specifications and must be approved by the respective vehicle manufacturer with the vehicle in its original, as-built configuration.

Contact Hendrickson for additional details regarding specifications, applications, capacities, and operation, service and maintenance instructions.

Call Hendrickson at 330.489.0045 or 866.RIDEAIR (743.3247) for additional information.



www.hendrickson-intl.com

TRAILER COMMERCIAL VEHICLE SYSTEMS

2070 Industrial Place SE
Canton, OH 44707-2641 USA
866.RIDEAIR (743.3247)
330.489.0045 • Fax 800.696.4416

Hendrickson Canada

250 Chrysler Drive, Unit #3
Brampton, ON Canada L6S 6B6
800.668.5360
905.789.1030 • Fax 905.789.1033

Hendrickson Mexicana

Circuito El Marqués Sur #29
Parque Industrial El Marqués
Pob. El Colorado, Municipio El Marqués,
Querétaro, México C.P. 76246
+52 (442) 296.3600 • Fax +52 (442) 296.3601