

# **BRAKE CERTIFICATIONS**

**SUBJECT:** Certifications for Air Actuated Brakes

**LIT NO:** L809

**DATE:** June 2020

**REVISION:** U

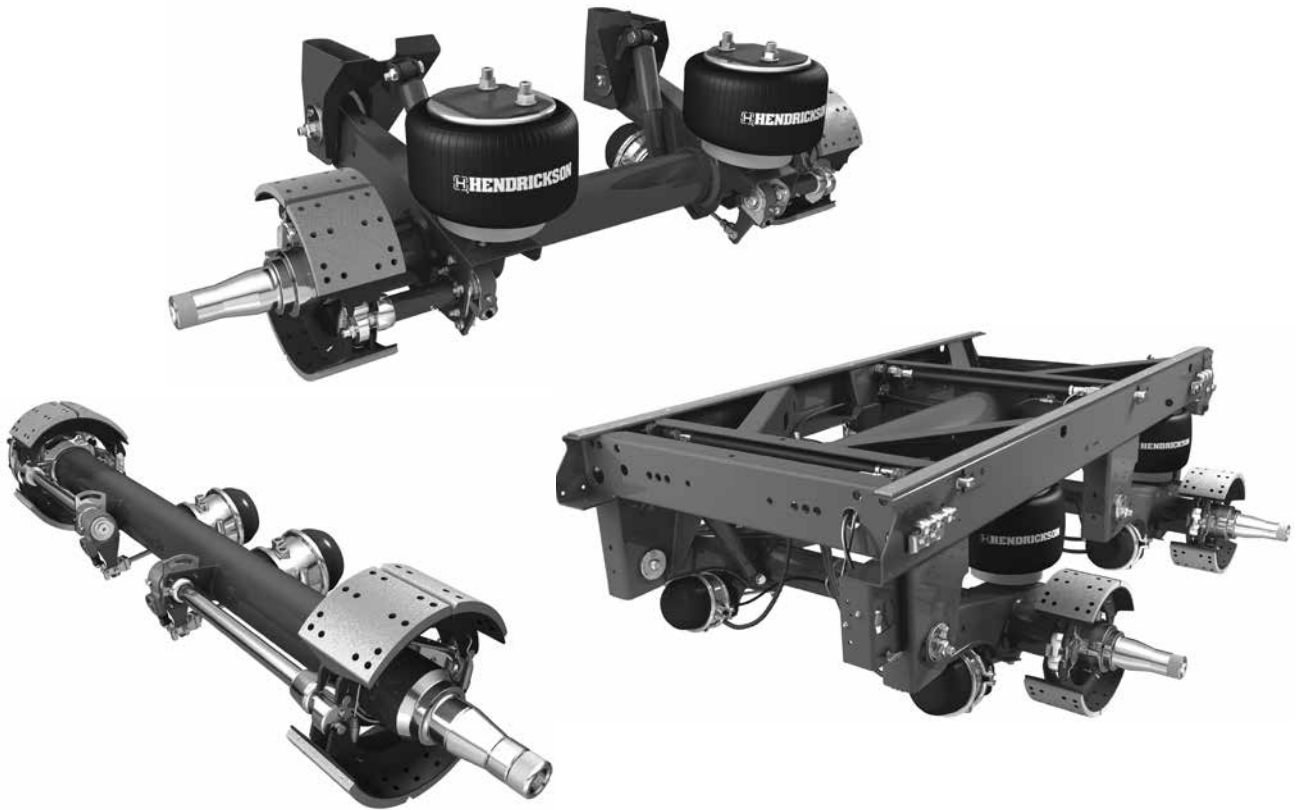

## TABLE OF CONTENTS

INTRODUCTION: Determining Brake Ratings .....	2
TIRE STATIC LOADED RADIUS (SLR) .....	3
FMVSS121 & CMVSS121 (North America) – DRUM BRAKES .....	4 - 5
FMVSS121 & CMVSS121 (North America) – DISC BRAKES .....	6 - 7
ECE REGULATION 13 CERTIFICATION (Europe & Asia) – DRUM & DISC BRAKES .....	8



## Determining Brake Ratings

Brake ratings are determined by the selection of several components including brake model and lining, brake chamber size and stroke, slack adjuster length and tire static loaded radius (SLR). For optimum performance, brakes should be selected based upon the maximum required load that is needed for the application and no higher. Hub, suspension, axle and tire ratings may all differ on a given trailer, and it is the minimum rated component of this group that determines the gross axle weight rating (GAWR).

Most North American on-highway applications only require brakes rated to 20,000 lb. GAWR. Suspension components may be specified at higher ratings for increased durability purposes, however higher rated brakes (above 20,000 lb. GAWR) should only be selected when running over weight or permitted loads. Using an overrated brake lining on your trailer can lead to excess brake torque which can result in premature tire and brake wear, noise and trailer hop. Contact Hendrickson Engineering for assistance in specifying the appropriate brake size for your application.

## Reading the Tables

BRAKE MODEL	LINING	BRAKE RATING	WHEN USED WITH:		
			CHAMBER SIZE	SLACK LENGTH	TIRE SLR
<p><b>Entries in this column indicate the brake model, size (drum diameter and shoe width) and identifies the Friction Material Standards Institute (FMSI) code for the brake.</b></p>	<p>Entries in this column indicate the lining manufacturer's name and lining formula designation.</p>	<p>Entries in this column indicate the lowest and highest Gross Axle Weight Rating (GAWR) in pounds for the given lining certification.</p> <p>The given certification is valid at any GAWR at or between the two stated values.</p>	<p>Entries in this column indicate size of the air chamber required to meet the certification for the given lining certification.</p> <p>The first number is the service chamber area (square inch).</p> <p>The second number is the Parking Chamber area # (square inch).</p> <p>Minimum rated stroke is listed in [brackets].</p>	<p>Entries in this column indicate length of the slack adjuster in inches required to meet the certification for the given lining certification.</p> <p>Note: There may be splits between a given GAWR and the slack length necessary to meet the certification.</p>	<p>Entries in this column indicate lowest and highest static loaded radius (SLR) for the tires in inches for the given lining certification.</p> <p>Note: There may be splits between a given GAWR and the tire SLR range necessary to meet the certification.</p>

**Example:** (Always read across the table for valid combinations)

BRAKE MODEL	LINING	BRAKE RATING	WHEN USED WITH:		
			CHAMBER SIZE	SLACK LENGTH	TIRE SLR
<p><b>HENDRICKSON 16.5" x 7" HXS® (F.M.S.I. 4707)</b></p>	H20167XF	17,000 – 20,000	<p>30/30 [2.5" stroke]</p>	<p>5.5" or 6.0"</p>	<p>17.0" – 20.8"</p>
	H23167XF	17,000 – 23,000			

### Example interpretations of the table entries:

- 16.5" x 7" HXS using H20167XF at 17,000 GAWR with 30/30 chamber, 5.5" slack and 20.8" SLR is valid.
- 16.5" x 7" HXS using H20167XF at 20,000 GAWR with 30/30 chamber, 5.5" slack and 19.3" SLR is valid.
- 16.5" x 7" HXS using H20167XF at 20,000 GAWR with 30/30 chamber, 5.5" slack and 17" SLR is valid.
- 16.5" x 7" HXS using H20167XF at 17,000 GAWR with 30/30 chamber, 6" slack and 17" SLR is valid.



## Static Loaded Radius (SLR)

Brake lining, chamber size and stroke, and slack adjuster size directly affect the amount of **torque** a brake can achieve. Brake **torque** is reacted through the wheel and tire, therefore the tire size will impact how much of that torque is converted to brake **force**. The static loaded radius (SLR) is the distance from the center of the axle to the ground under maximum rated load when the tire is inflated to the recommended pressure. For a given brake **torque**, as SLR increases, brake **force** decreases. It is important to ensure that you are using the appropriate tires and brake components for the required brake rating.

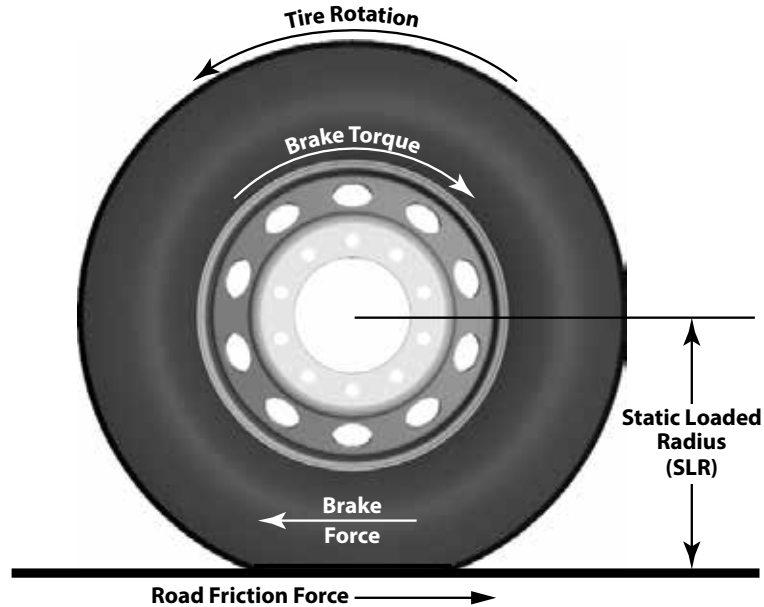

The charts below summarize standard on-highway trailer tire sizes and the typical static loaded radius (SLR) for trailer tread patterns. Please consult the tire manufacturer for the exact SLR for the size, tread and load range of your specific tire.

RIM SIZE	TIRE SIZE	STATIC LOAD RADIUS (SLR)
17.5	9R17.5	15.4
	10R17.5	15.6
	215/75R17.5	14.1 - 14.2
	235/75R17.5	14.3 - 14.7
	245/70R17.5	14.2 - 14.5
19.5	245/70R19.5	15.3
	265/70R19.5	15.7
	285/70R19.5	16.1 - 16.2
	445/45R19.5	16.3
22.5	11R22.5	19 - 19.3
	255/70R22.5	16.9 - 17.1
	275/70R22.5	17.4

RIM SIZE	TIRE SIZE	STATIC LOAD RADIUS (SLR)
22.5	275/80R22.5	18.4 - 18.6
	295/75R22.5	18.5 - 18.7
	385/55R22.5	18.1
	385/65R22.5	19.5
	425/65R22.5	20.3
	445/65R22.5	20.8
	445/50R22.5	18.1 - 18.6
	455/55R22.5	19.6 - 19.4
24.5	11R24.5	20 - 20.3
	275/80R24.5	19.1 - 19.2
	285/75R24.5	19 - 19.5



## FMVSS-121 / CMVSS-121 Brake Certification — Drum Brakes

Federal Motor Vehicle Standards specify that the original equipment manufacturer (OEM) is responsible for compliance to Federal Motor Vehicle Safety Standard (FMVSS)-121 for air actuated brakes. In the United States, OEMs are self-certifying to the standard. In Canada, test data must be submitted to Transport Canada either directly or indirectly through the Canadian Transport Equipment Association's (CTEA) brake database (Note - CTEA database is available to CTEA members only).

As a service to our customers, Hendrickson Trailer Commercial Vehicle Systems provides this **Consolidated Certificate of Compliance** for use with Hendrickson INTRAAX®, VANTRAAX® and VANTRAAX® ULTRA-K® integrated suspension systems and TRLAXLE® non-integrated axles. For every entry in the table, Hendrickson has data showing compliance to FMVSS-121 requirements. As an additional service to Canadian customers who must provide parking test compliance data to Transport Canada, FMVSS/CMVSS-121 parking data is also available upon request for every table entry. This data is a part of the CTEA database. **For certifications other than those listed in these tables, please contact Hendrickson Brake Engineering for an application specific approval.**

### 12.25" × 7.5" Brake Certificate of Compliance

This table certifies that the Hendrickson TRLAXLE non-integrated axles described below comply with the current revision of DOT 49 CFR 571.121 and Canadian Motor Vehicle Safety Standards, Service Brakes, Par. S5.4 and Parking Brakes, Par.5.6.1 when equipped as noted.

**For certifications other than those listed below, please contact Hendrickson Brake Engineering for an application specific approval.**

BRAKE MODEL	LINING	BRAKE RATING	WHEN USED WITH:		
			CHAMBER SIZE	SLACK LENGTH	TIRE SLR
HENDRICKSON 12.25" × 7.5" HXS <sup>®1</sup> (F.M.S.I. 4692)	H20127XF	15,000 – 17,000	24/24 <sup>2</sup> [2.5" stroke]	5.5" or 6.0" <sup>3</sup>	14.3" – 15.6"
		17,000 – 20,000	30/30 [3.0" stroke]	5.5" or 6.0" <sup>3</sup>	14.3" – 15.6"
	H20127XH	15,000 – 17,000	24/24 <sup>2</sup> [2.5" stroke]	5.5" or 6.0" <sup>3</sup>	14.3" – 15.6"
		17,000 – 20,000	30/30 [3.0" stroke]	5.5" or 6.0" <sup>3</sup>	14.3" – 15.6"

1. 12.25" brakes are usually used with 17.5" wheel equipment. Users should review tractor brake configurations to assure correct brake balance.
2. Do not use older Type 24 service chambers rated at 1.75" stroke.
3. When 6.0" slacks are chosen, long stroke chambers are recommended.

### 15" × 8.625" HXS<sup>®</sup> Brake Certificate of Compliance

This table certifies that the Hendrickson INTRAAX integrated suspension system and TRLAXLE non-integrated axles described below comply with the current revision of DOT 49 CFR 571.121 and Canadian Motor Vehicle Safety Standards, Service Brakes, Paragraph S5.4, and Parking Brakes, Paragraph 5.6.1, when equipped as noted. **For certifications other than those listed below, please contact Hendrickson Brake Engineering for an application specific approval.**

BRAKE MODEL	LINING	BRAKE RATING	WHEN USED WITH:		
			CHAMBER SIZE	SLACK LENGTH	TIRE SLR
HENDRICKSON 15" × 8.625" HXS <sup>1</sup> (F.M.S.I. 4710)	H20158XF	13,700 – 18,750	24/24 <sup>2</sup> [2.5" stroke] or	5.5" or 6.0" <sup>3</sup>	14.9" – 16.3"
		17,000 – 20,000	24/30 <sup>2</sup> [2.5" stroke]	6.0" <sup>3</sup>	
		17,000 – 20,000	30/30 [2.5" stroke]	5.5" or 6.0" <sup>3</sup>	
	H20158XH	13,700 – 18,750	24/24 <sup>2</sup> [2.5" stroke] or	5.5" or 6.0" <sup>3</sup>	14.9" – 16.6"
		17,000 – 20,000	24/30 <sup>2</sup> [2.5" stroke]	6.0" <sup>3</sup>	
		17,000 – 20,000	30/30 [2.5" stroke]	5.5" or 6.0" <sup>3</sup>	

1. 15" brakes are usually used with 19.5" wheel equipment. Users should review tractor brake configurations to assure correct brake balance.
2. Do not use older Type 24 service chambers rated at 1.75" stroke.
3. When 6.0" slacks are chosen, long stroke chambers are recommended.

**FMVSS-121 / CMVSS-121 Brake Certification — Drum Brakes (Continued)****16.5" x 7" Brake Certificate of Compliance**

This table certifies that the Hendrickson INTRAAX®, VANTRAAX® and VANTRAAX® ULTRAA-K® integrated suspension systems and TRLAXLE® non-integrated axles described below comply with the current revision of DOT 49 CFR 571.121 and Canadian Motor Vehicle Safety Standards, Service Brakes, Paragraph S5.4, and Parking Brakes, Paragraph 5.6.1, when equipped as noted. **For certifications other than those listed below, please contact Hendrickson Brake Engineering for an application specific approval.** All tests were performed on 112-pound cast drums. 120-pound heavy duty drums are required for applications greater than 23,000 lbs.

BRAKE MODEL	LINING	BRAKE RATING	WHEN USED WITH:		
			CHAMBER SIZE	SLACK LENGTH	TIRE SLR
<b>HENDRICKSON 16.5" x 7" Standard (F.M.S.I. 4515)</b>	H20167SF	17,000 – 20,000	30/30 [2.5" stroke]	5.5" or 6.0" <sup>3</sup>	17" – 20.8"
	H23167SF	17,000 – 23,000			
<b>HENDRICKSON 16.5" x 7" HXS® (F.M.S.I. 4707)</b>	H20167XF	17,000 – 20,000	30/30 [2.5" stroke]	5.5" or 6.0" <sup>3</sup>	17" – 20.8"
	H23167XF	17,000 – 23,000			
	H23167XH	17,000 – 23,000	30/30 [2.5" stroke]	5.5" or 6.0" <sup>3</sup>	17" – 20.8"
	Hendrickson ULTRAA20	17,000 – 20,000	30/30 [2.5" stroke]	5.5" or 6.0" <sup>3</sup>	17" – 20.3"
	H26167XF	23,000 – 26,000		6.0" <sup>3</sup>	17" – 20.8"
	H20167XF	10,000 – 14,600	20/24 [2.5" stroke]	5.5"	17" – 21.1"

3. When 6.0" slacks are chosen, long stroke chambers are recommended.

**16.5" x 8.625" HXS® Brake Certificate of Compliance**

This table certifies that the Hendrickson INTRAAX, VANTRAAX and VANTRAAX ULTRAA-K integrated suspension systems and TRLAXLE non-integrated axles described below comply with the current revision of DOT 49 CFR 571.121 and Canadian Motor Vehicle Safety Standards, Service Brakes, Paragraph S5.4, and Parking Brakes, Paragraph 5.6.1, when equipped as noted. **For certifications other than those listed below, please contact Hendrickson Brake Engineering for an application specific approval.** All tests were performed on 123-pound cast drums.

BRAKE MODEL	LINING	BRAKE RATING	WHEN USED WITH:		
			CHAMBER SIZE	SLACK LENGTH	TIRE SLR
<b>HENDRICKSON 16.5" x 8.625" HXS (F.M.S.I. 4711)</b>	H20168XF	17,000 – 20,000	30/30 [2.5" stroke]	5.5" or 6.0" <sup>3</sup>	17" – 20.8"
		20,000 – 22,500		6.0" <sup>3</sup>	
	H23168XF	17,000 – 23,000		5.5" or 6.0" <sup>3</sup>	
		23,000 – 25,000		6.0" <sup>3</sup>	
	Hendrickson ULTRAA20™	17,000 – 23,000	30/30 [2.5" stroke]	5.5" or 6.0" <sup>3</sup>	17" – 20.8"
	H26168XF	23,000 – 25,000	30/30 [2.5" stroke]	5.5" or 6.0" <sup>3</sup>	17" – 20.8"
		25,000 – 29,000	30/30 [3.0" stroke]	6.0"	17" – 22.4"

3. When 6.0" slacks are chosen, long stroke chambers are recommended.



**FMVSS-121 / CMVSS-121 Brake Certification — Disc Brakes**

**22.5" / 24.5" Air Disc Brake Certificate of Compliance**

This table certifies that the Hendrickson INTRAAX<sup>®</sup>, VANTRAAX<sup>®</sup> and VANTRAAX<sup>®</sup> ULTRAA-K<sup>®</sup> integrated suspension systems and TRLAXLE<sup>®</sup> non-integrated axles described below comply with the current revision of DOT 49 CFR 571.121 and Canadian Motor Vehicle Safety Standards, Service Brakes, Par. S5.4 and Parking Brakes, Par. 5.6.1 when equipped as noted. **For certifications other than those listed below, please contact Hendrickson Brake Engineering for an application specific approval.**

BRAKE MODEL	BRAKE ROTOR	LINING	BRAKE RATING	WHEN USED WITH:	
				CHAMBER SIZE	TIRE SLR
HENDRICKSON MAXX22T™	415mm × 43mm Rotor	WABCO 233 (Jurid 539-20)	17,000 – 20,000	18/24	17" – 20.8"
			17,000 – 22,400		17" – 20.3"
			17,000 – 23,000		17" – 19.3"
Haldex DB22	430mm × 45mm Rotor	Jurid 539-20	23,000 - 25,000	20/24	17" – 20.8"
Haldex DBT22LT	430mm × 45mm Rotor	Jurid 442	17,000 – 20,000	18/24	17" – 20.8"
			17,000 – 22,400		17" – 20.3"
			17,000 – 23,000		17" – 19.3"
Bendix Spicer (Knorr) ADB22X	430mm × 45mm Rotor	Jurid 539-29 (BX275)	17,000 – 23,000	18/24	17" – 20.8"
Bendix Spicer ADB22X-LT	430mm × 45mm Rotor	BX276	17,000 - 23,000	18/24	17" - 20.8"
WABCO PAN22	430mm × 45mm Rotor	WABCO 230 or WABCO 232	17,000 – 23,000	20/24	17" – 20.8"
HENDRICKSON MAXX22T	415mm × 43mm Rotor	WABCO 233 (Jurid 539-20)	12,200 – 13,500	14/24	17" – 21.7"

**19.5" Air Disc Brake Certificate of Compliance**

This table certifies that the Hendrickson INTRAAX<sup>®</sup> integrated suspension systems and TRLAXLE<sup>®</sup> non-integrated axles described below comply with the current revision of DOT 49 CFR 571.121 and Canadian Motor Vehicle Safety Standards, Service Brakes, Par. S5.4 and Parking Brakes, Par. 5.6.1 when equipped as noted. **For certifications other than those listed below, please contact Hendrickson Brake Engineering for an application specific approval.**

BRAKE MODEL	BRAKE ROTOR	LINING	BRAKE RATING	WHEN USED WITH:	
				CHAMBER SIZE	TIRE SLR
WABCO PAN19	375mm × 45mm Rotor	WABCO 230	13,700 - 20,000	16/24	14.8" – 16.6"
WABCO PAN19	375mm × 45mm Rotor	WABCO 230	13,700 - 20,000	18/24	14.8" – 16.6"

**17.5" Air Disc Brake Certificate of Compliance**

This table certifies that the Hendrickson TRLAXLE<sup>®</sup> non-integrated axle described below comply with the current revision of DOT 49 CFR 571.121 and Canadian Motor Vehicle Safety Standards, Service Brakes, Par. 55.4 and Parking Brakes, Par.5.6.1 when equipped as noted. **For certifications other than those listed below, please contact Hendrickson Brake Engineering for an application specific approval.**

BRAKE MODEL	BRAKE ROTOR	LINING	BRAKE RATING	WHEN USED WITH:	
				CHAMBER SIZE	TIRE SLR
WABCO PAN17	325mm × 34mm Rotor	Jurid 539	15,000 - 17,500	18/24	14.1" – 15.6"
			17,500 - 20,000	20/24	14.1" – 14.7"

**ECE Regulation 13 Brake Certification**

The tables below certify that the Hendrickson INTRAAX<sup>®</sup>, VANTRAAX<sup>®</sup> and VANTRAAX<sup>®</sup> ULTRAAX-K<sup>®</sup> integrated suspension systems and TRILAXLE<sup>®</sup> non-integrated axles described below comply with the current revision of ECE Regulation 13.11 Appendix 3-5 of Annex 11, Annex 4 item 3.3 and Appendix 1-4 of Annex 19. **For certifications other than those listed below, please contact Hendrickson Brake Engineering for an application specific approval.**

**Drum Brakes**

BRAKE MODEL	LINING	AXLE STATIC LOAD	ECE REPORT	NOTES
<b>HENDRICKSON 16.5" x 7" HXS<sup>®</sup> (F.M.S.I. 4707)</b>	H20167XF	9,000 kg	USS380688-2	Active
	ABEX 3030-197	9,000 kg	USL222548-1	Discontinued
	ABEX ULTRAAX20™	10,000 kg	USL222548-2	Active
	H26167XF	13,000 kg	USL222548-6-01	Active
<b>HENDRICKSON 16.5" x 8.625" HXS (F.M.S.I. 4711)</b>	H20168XF	10,000 kg	USP286647-2	Active
	ABEX ULTRAAX20	10,000 kg	USL222548-3	Active
	H26168XF	14,000 kg	USL222548-5-01	Active
<b>HENDRICKSON 15" x 8.625" HXS (F.M.S.I. 4710)</b>	H20158XH	9,000 kg	UST424762-1	Active
<b>HENDRICKSON 12.25" x 7.5" HXS<sup>1</sup> (F.M.S.I. 4692)</b>	H20127XH	9,000 kg	USS367273-1	Active

1. 12.25" brakes are usually used with 17.5" wheel equipment. Users should review tractor brake configurations to assure correct brake balance.

**Air Disc Brakes**

BRAKE MODEL	BRAKE ROTOR	LINING	AXLE STATIC LOAD	ECE REPORT	NOTES
<b>HENDRICKSON MAXX22T™</b>	415 mm x 43 mm	WABCO233	10,500 kg	36103515	Active
<b>WABCO PAN22</b>	430 mm x 45 mm	WABCO230 or WABCO232	10,500 kg	36102015	Active
<b>HALDEX DB22 MODULE X</b>	430 mm x 45 mm	Jurid 539	11,600 kg	36104918	Active

**Important Air Disc Application Information****1. Wheel and Valve Stem Packaging**

Great care must be taken in selecting combinations of wheel and valve stem products that are compatible with air disc brakes. OEM customers will need to review wheel-end and valve stem packaging with the selected disc brake manufacturer to confirm adequate running clearances. Hendrickson Brake Engineering can assist customers in discussions with the disc brake manufacturer.

**2. ABS Sensors**

Hendrickson fully dressed air disc brake suspensions require straight ABS sensors. Depending on caliper model, ABS sensing may be via hub-mounted tone rings or rotor-mounted tone rings.

**3. Air Chamber Selection and Vehicle Balance**

Default air chamber selection is based on the choice of caliper brand and lining. Additional sizes are available if necessary. Trailer OEM customers are encouraged to work with end customers to review mating tractor brake specifications and determine if combined vehicle brake balance is correct for the application. Hendrickson Brake Engineering will assist customers in discussions with the disc brake manufacturer.

**4. Air Disc Application Form**

Required by air disc manufacturer for North American applications — The application approval is not required for the Hendrickson MAXX22T™ system. Application forms can be found on the last page of the product ordering guide.

*Actual product performance may vary depending upon vehicle configuration, operation, service and other factors.  
All applications must comply with applicable Hendrickson specifications and must be approved by the respective vehicle manufacturer with the vehicle in its original, as-built configuration.  
Contact Hendrickson for additional details regarding specifications, applications, capacities, and operation, service and maintenance instructions.*

**Call Hendrickson at 330.489.0045 or 866.RIDEAIR (743.3247) for additional information.**



[www.hendrickson-intl.com](http://www.hendrickson-intl.com)

**TRAILER COMMERCIAL VEHICLE SYSTEMS**

2070 Industrial Place SE  
Canton, OH 44707-2641 USA  
866.RIDEAIR (743.3247)  
330.489.0045 • Fax 800.696.4416

**Hendrickson Canada**

250 Chrysler Drive, Unit #3  
Brampton, ON Canada L6S 6B6  
800.668.5360  
905.789.1030 • Fax 905.789.1033

**Hendrickson Mexicana**

Circuito El Marqués Sur #29  
Parque Industrial El Marqués  
Pob. El Colorado, Municipio El Marqués,  
Querétaro, México C.P. 76246  
+52 (442) 296.3600 • Fax +52 (442) 296.3601

L809 Rev U 06-20

© 2002 - 2020 Hendrickson USA, L.L.C. All Rights Reserved. All trademarks shown are owned by Hendrickson USA, L.L.C., or one of its affiliates, in one or more countries.  
Information contained in this literature was accurate at the time of publication. Product changes may have been made after the copyright date that are not reflected.

Printed in United States of America