

# H PARTS LIST

## PRIMAAX® EX Rear Air Suspension for Caterpillar Vehicles Built PRIOR TO 2/2016

LIT NO: SP-234

DATE: September 2017

REVISION: C

### CONTENTS

DESCRIPTION	PAGE	DESCRIPTION	PAGE
Technical Notes . . . . .	2	Parts List	
Selection Guide		<ul style="list-style-type: none"> <li>■ 23K • 46K • 69K – 9"-10½" Ride Height . . . . . 4</li> <li>■ 23K • 46K • 69K – 13" Ride Height. . . . . 6</li> <li>■ 26K – 9" Ride Height . . . . . 8</li> </ul>	
<ul style="list-style-type: none"> <li>■ Bottom Cap, Longitudinal Torque Rod Assembly and Torque Rod Spacer . . . . . 3</li> <li>■ U-beam Assembly Enhancement Aftermarket Service Kit . . . . . 3</li> </ul>		Severe Service Kits . . . . .	10
		Notes . . . . .	10
		Special Tools . . . . .	11

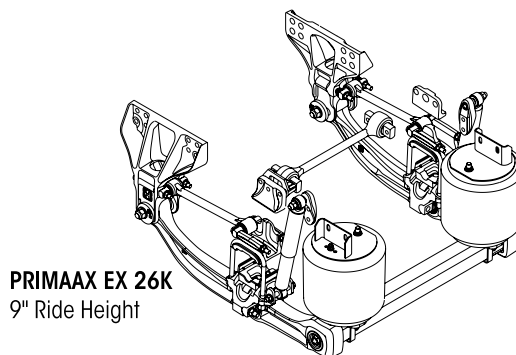
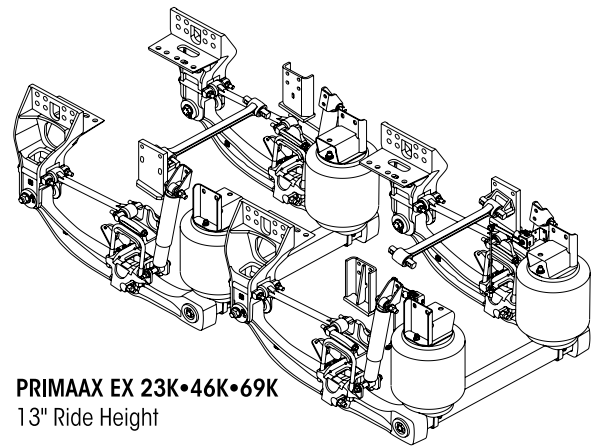
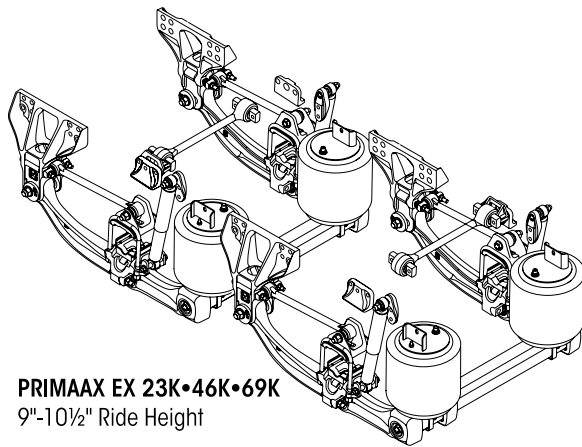

### Technical Notes

The following information is intended to assist in determining which suspension is equipped on Caterpillar vehicles. As an example, Figure 1 identifies the ride height.

FIGURE 1

**RIDE HEIGHT**

9" Ride Height

PRIMAAX EX  
Frame Hanger

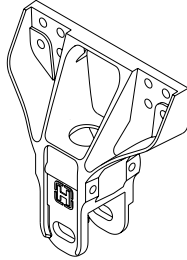

**AND**  
Axle Spacer

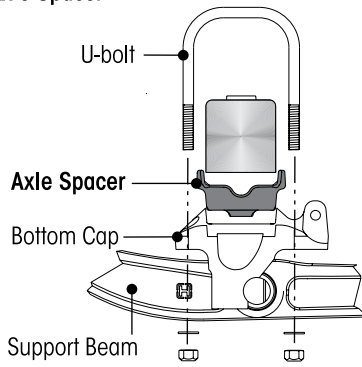

10½" Ride Height

PRIMAAX EX  
Frame Hanger

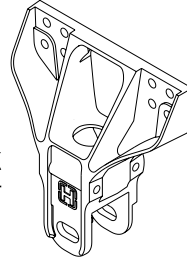

**AND**  
No Axle Spacer

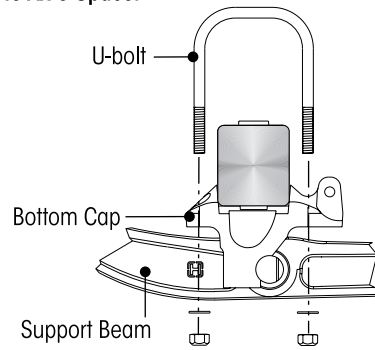

13" Ride Height

PRIMAAX EX  
Frame Hanger

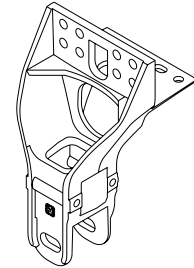

**AND**  
Axle Spacer

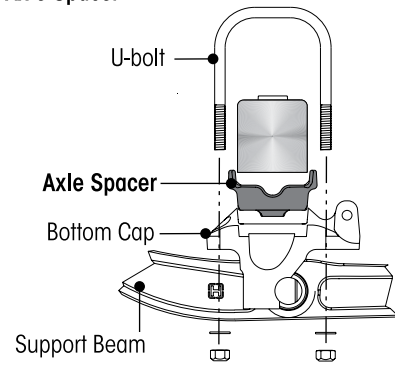

**PRIMAAX EX 23K • 46K • 69K**
**Bottom Cap, Longitudinal Torque Rod Assembly and Torque Rod Spacer**

Page 4	9", 10½" Ride Heights,
Page 6	13" Ride Height

	Bottom Cap (2 per axle)	♦Longitudinal Torque Rod Assembly (2 per axle)	Torque Rod Spacer (4 per axle)		Pinion Angle	
	Part No.	Part No.	Part No.	Thickness		
				mm		Inches
	60556-035	67274-510	Not Required		2.54	
			67045-072	6.35	¼	3.61
			67045-071	12.7	½	4.56
			67045-070	19	¾	5.72
			67045-069	25.4	1	6.71
	60556-100	67274-540	Not Required		6.62	
			67045-072	6.35	¼	7.67
			67045-071	12.7	½	8.62
			67045-070	19	¾	9.77
			67045-069	25.4	1	10.75
	60556-105		Not Required		7.07	
			67045-072	6.35	¼	8.12
67045-071			12.7	½	9.06	
67045-070			19	¾	10.22	
			67045-069	25.4	1	11.20

**NOTE:** \*Non-serviceable torque rod bushings, requires replacement of complete torque rod assembly with bushings.

**U-beam Assembly Enhancement Aftermarket Service Kit**
**Service Kit No. 69565-001, Axle Set**

PART NO.	DESCRIPTION	QTY.	COMMENTS
69351-000	Sikaflex 221 Polyurethane Sealant, 300 ml Tube	1	In the event any service to the suspension requiring disassembly of a U-beam assembly equipped with integrated end caps, the Loctite 277, tamper resistant caps and Sikaflex 221 polyurethane sealant must be properly installed to ensure components function to their highest efficiency.
69570-000	Loctite® 277 - 10 ml Bottle	1	
**	Tamper Resistant Cap	2	
**	⅞"-9 UNC x 3¾" Hex Bolt	2	
**	⅞" H-Coat Flat Washer	2	



9", 10½" Ride Heights

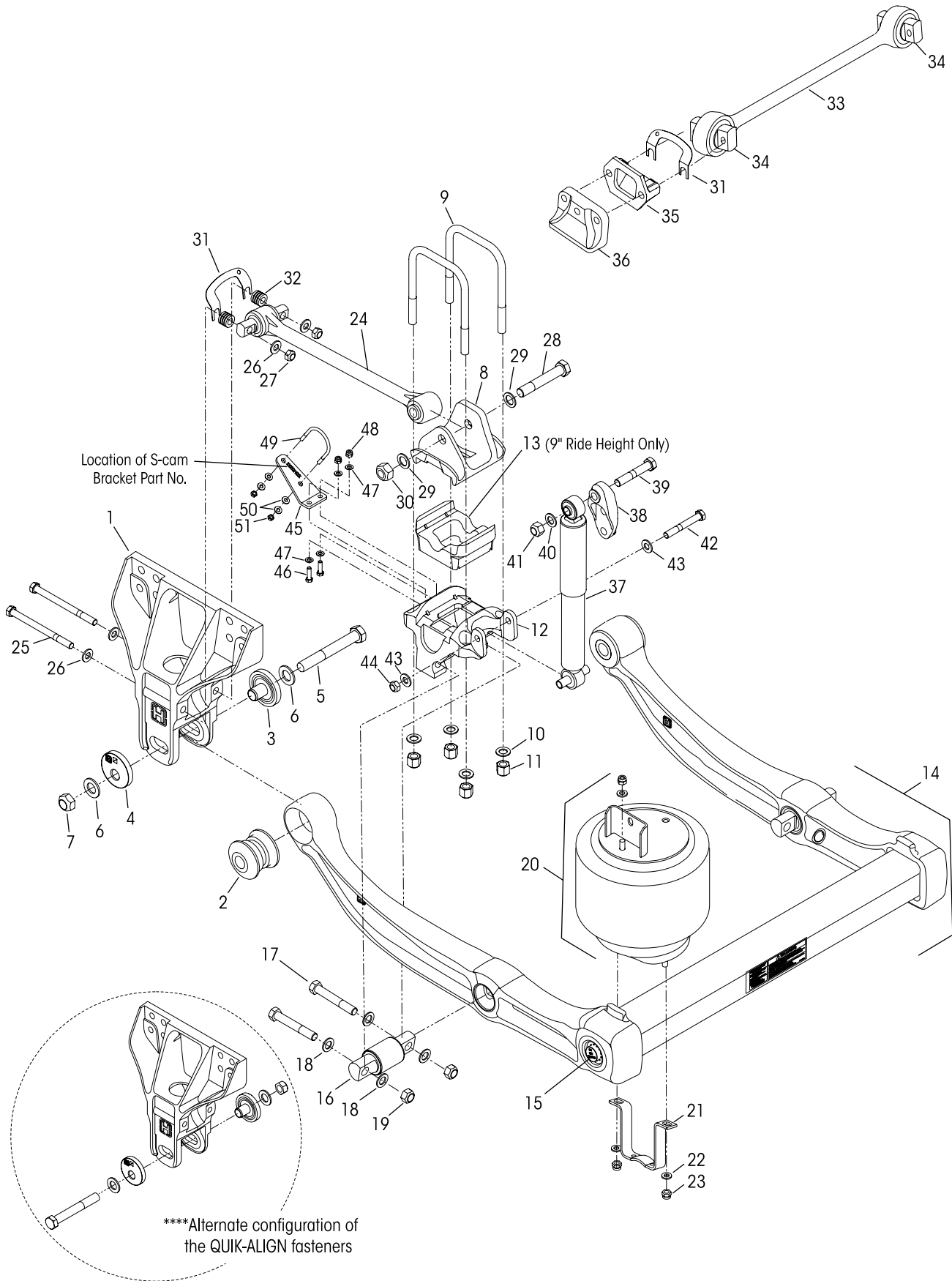



KEY NO.	PART NO.	DESCRIPTION	*VEHICLE QTY.	KEY NO.	PART NO.	DESCRIPTION	*VEHICLE QTY.
1	67706-000	Frame Hanger	4	18		**3/4" Flat Washer	16
		<b>QUIK-ALIGN® Pivot Bushing Service Kit,</b> Includes Key Nos. 2-7, 52		19		**3/4"-16 UNF Locknut	8
	60961-720	One Wheel End			60961-664	<b>Single Air Spring Service Kit,</b> Includes Key Nos. 20-23	
	60632-020	Axle Set		20	67234-002L	Air Spring Assembly, Includes Upper Frame Bracket and Fasteners	4
		<b>QUIK-ALIGN Collar Service Kit,</b> Includes Key Nos. 3-7		21	60911-002	Lower Air Spring Mounting Bracket	4
	60632-019	One Wheel End, Replaces 60632-006			49177-006	<b>Lower Air Spring Fastener Service Kit, Single,</b> Includes Key Nos. 22-23	
	60632-021	Axle Set		22		**1/2" Flat Washer	8
	60632-018	<b>QUIK-ALIGN Fastener Service Kit, One Wheel End,</b> Includes Key Nos. 5-7, Replaces 60632-005		23		**1/2"-13 UNC Locknut	8
2		**Pivot Bushing	4	24		Longitudinal Torque Rod Assembly <i>See Selection Guide on Page 3</i>	4
3		**Concentric Collar	4		49176-026	<b>Single Longitudinal Torque Rod Fastener Kit</b> Thru Bolt and Barpin Connection, Includes Key Nos. 25-30	
4		**Eccentric Collar	4		58821-012	Rear Thru Bolt Connection Only, Includes Key Nos. 28-30	
5		**1"-14 UNF-2A x 7 1/2" H-Coat Hex Bolt	4	25		**5/8"-11 UNC-2B x 8" Bolt	8
6		**1" H-Coat Flat Washer,	8	26		**3/8" Flat Washer	16
7		**1"-14 UNF-2B H-Coat Locknut	4	27		**5/8"-11 UNC-2A Locknut	8
8	65290-001	Top Pad	4	28		**7/8"-14 UNF-2A x 5 1/2" Hex Bolt	4
		<b>U-bolt Service Kit, One Wheel End,</b>		29		**7/8" H-Coat Flat Washer	8
	48718-108	10 1/2" Ride Height, Includes Key Nos. 9a, 10-11		30		**7/8"-14 UNF-2B Locknut	4
	48718-125	9" Ride Height, Includes Key Nos. 9b, 10-11		31	49689-000L	Shim	As Req.
9		**3/4" Square U-bolt	8	32	67045-XXX	Torque Rod Spacer, <i>See Selection Guide on Page 3</i>	
a		8 7/8" Length - 10 1/2" Ride Height		33	72000-XXXS	***ULTRA ROD® PLUS™ Transverse Torque Rod Assembly, Includes Key No. 34, Specify length in mm	2
b		10 3/8" Length - 9" Ride Height		34	64400-002L	Bushing - Straddle Bar Pin (5/8" Holes)	4
10		**3/4" Flat Washer	16	35	22186-000	Transverse Torque Rod Frame Bracket	2
11		**3/4"-16 UNF U-bolt Locknut	16	36	60593-000	Axle Stop, Frame Mounted	4
12	60556-XXX	Bottom Cap - Front and Rear, <i>See Selection Guide on Page 3</i>	4	37a	60657-003	Shock Absorber	4
13	65139-003	Axle Spacer, 9" Ride Height	4	b	70807-001	Heavy-duty Shock Absorber, Optional	4
14		U-beam Assembly, Includes Key Nos. 2, 16	2	38	67463-002	Upper Shock Frame Bracket	4
		• Front Frame Width			50754-030	<b>Single Shock Fastener Service Kit,</b> Includes Key Nos. 39-44	
	67249-004	34.0"		39		**3/4"-10 UNC x 4 1/4" Upper Shock Bolt	4
	67249-012	34.3"		40		**3/4" Flat Washer	4
	67249-010	34.5"		41		**3/4"-10 UNC Locknut	4
	67249-024	34.8"		42		**5/8"-11 UNC x 6" Lower Shock Bolt	4
	67249-018	35.0"		43		**5/8" Flat Washer	8
		• Rear Frame Width		44		**5/8"-11 UNC-2B Locknut	4
	67249-003	34.0"		45	64508-XXX	S-cam Support Bracket <i>See Part No. on component</i>	4
	67249-011	34.3"			58821-017	<b>S-cam Fastener Service Kit, Axle Set,</b> Includes Key Nos. 46-51	
	67249-009	34.5"		46		**3/8"-16 UNC x 1 1/4" Hex Bolt	8
	67249-023	34.8"		47		**3/8" Hardened Washer	16
	67249-017	35.0"		48		**3/8"-16 UNC Locknut	8
15	69565-001	<b>U-beam Assembly Enhancement Aftermarket Service Kit, Axle Set, See Page 3 for contents</b>		49		**5/16" S-cam U-bolt	4
		<b>Single D-Pin Bushing Service Kit,</b>		50		**5/16" Hardened Washer	16
	34013-107	Includes Key Nos. 16, 17a, 18-19		51		**5/16"-18 UNC Locknut	8
	34013-116	Includes Key Nos. 16, 17b, 18-19		52	70867-001	P-80 Lubricant - 10 ml (Not Shown) per Bushing	1
	34013-117	Includes Key Nos. 16, 17c, 18-19					
16		**D-Pin Bushing	4				
		<b>D-Pin Fastener Service Kit, Axle Set,</b>					
	56659-009	Includes Key Nos. 17a, 18-19					
	56659-013	Includes Key Nos. 17b, 18-19					
	56659-012	Includes Key Nos. 17c, 18-19					
17		**3/4"-16 UNF Bolt	8				
a		5" Length					
b		5 1/2" Length					
c		4 3/4" Length					



13" Ride Height

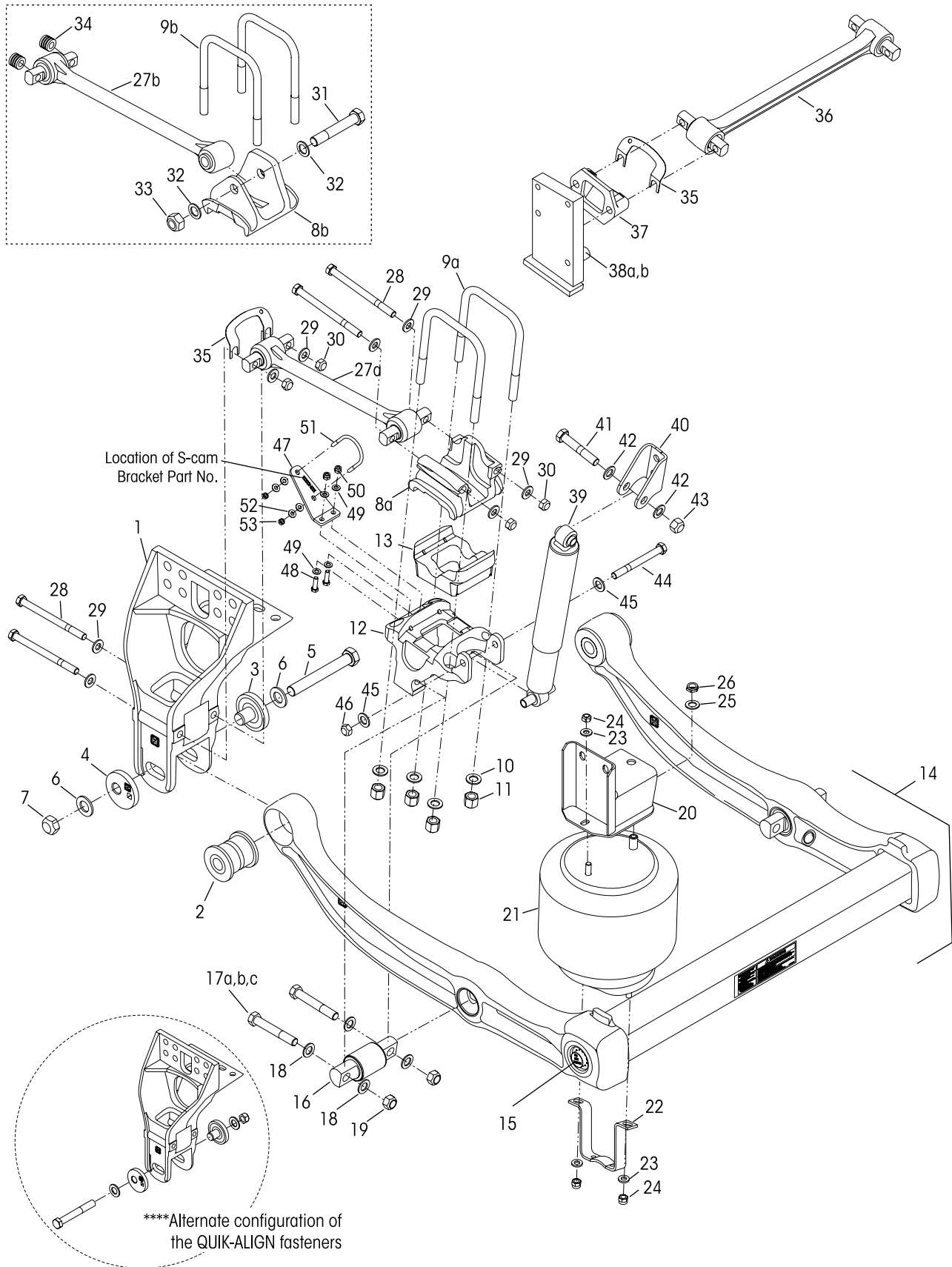



			*VEHICLE				*VEHICLE
KEY NO.	PART NO.	DESCRIPTION	QTY.	KEY NO.	PART NO.	DESCRIPTION	QTY.
1		Frame Hanger		20	65031-001	Upper Air Spring Bracket Assembly	4
	67299-001	LH	2		60961-724	<b>Single Air Spring Service Kit,</b> Includes Key Nos. 21-26	
	67299-002	RH	2	21	68070-002L	Air Spring Assembly	4
		<b>QUIK-ALIGN® Pivot Bushing Service Kit,</b> Includes Key Nos. 2-7, 54		22	60911-002	Lower Air Spring Mounting Bracket	4
	60961-720	One Wheel End				<b>Air Spring Fastener Service Kit, Single</b> Lower, Includes Key Nos. 23-24	
	60632-020	Axle Set			49177-006	Upper/Lower, Includes Key Nos. 23-26	
		<b>QUIK-ALIGN Collar Service Kit,</b> Includes Key Nos. 3-7		23		**1/2" Flat Washer	12
	60632-019	One Wheel End, <i>Replaces 60632-006</i>		24		**1/2"-13 UNC Locknut	12
	60632-021	Axle Set		25		**3/4" Flat Washer	4
	60632-018	<b>QUIK-ALIGN Fastener Service Kit, One Wheel End,</b> Includes Key Nos. 5-7, <i>Replaces 60632-005</i>		26		**3/4"-16 UNF Locknut	4
2		**Pivot Bushing	4	27		Longitudinal Torque Rod Assembly, Includes Bushings. Specify length in mm	4
3		**Support Beam Concentric Collar	4	a	62043-430N	430 mm	
4		**Support Beam Eccentric Collar	4	a	62039-440N	440 mm	
5		**1" -14 UNF-2A x 7 1/2" H-Coat Hex Bolt	4	a	62040-475N	475 mm	
6		**1" H-Coat Flat Washer	8	b	67274-510	510 mm	
7		**1" -14 UNF-2B H-Coat Locknut	4	b	67274-540	540 mm	
8		Top Pad	4			<b>Single Longitudinal Torque Rod Fastener Kit</b> Thru Bolt and Barpin Connection, Includes Key Nos. 28-33	
a	65289-000	Bar Pin Style			49176-026	2-Bar Pin Connections, Includes Key Nos. 28-30	
b	65290-001	Thru Bolt Style			49176-032	Rear Thru Bolt Connection Only, Includes Key Nos. 31-33	
		<b>U-bolt Service Kit, One Wheel End,</b> Includes Key Nos. 9a, 10-11 (Bar Pin Style)			58821-012		
	48718-130	Includes Key Nos. 9b, 10-11 (Thru Bolt Style)		28		**5/8"-11 UNC x 8" Bolt	16
	48718-125			29		**5/8" Flat Washer	32
9		**3/4" Square U-bolt	8	30		**5/8"-11 UNC Locknut	16
a		10 3/8" Length, Bar Pin Style		31		**7/8"-14 UNF-2A x 5 1/2" Hex Bolt	4
b		10 3/8" Length, Thru Bolt Style		32		**7/8" H-Coat Flat Washer	8
10		**3/4" Flat Washer	16	33		**7/8"-14 UNF-2B Locknut	4
11		**3/4"-16 UNF U-bolt Locknut	16	34	67045-XXX	Torque Rod Spacer, <i>See Selection Guide on Page 3</i>	
12	60556-XXX	Bottom Cap, <i>See Selection Guide on Page 3</i>	4	35	49689-000L	Shim	As Req.
13	65139-003	Axle Spacer (required)	4	36	62011-XXXN	**Transverse Torque Rod Assembly, Includes Bushings. Specify length in mm	2
14		U-beam Assembly, Includes Key Nos. 2, 16	2	37	22186-000	Transverse Torque Rod Frame Bracket	2
		• Front Frame Width		38		Axle Stop, Frame Mounted	4
	67249-004	34.0"		a	65510-001	0° Axle Tower	
	67249-012	34.3"		b	65510-002	20° Axle Tower	
	67249-010	34.5"		39	60665-011	Shock Absorber	4
	67249-024	34.8"		40	59423-001	Upper Shock Frame Bracket	4
	67249-018	35.0"			50754-030	<b>Single Shock Fastener Service Kit,</b> Includes Key Nos. 41-46	
		• Rear Frame Width		41		**3/4"-10 UNC x 4 1/4" Upper Shock Bolt	4
	67249-003	34.0"		42		**3/4" Flat Washer	8
	67249-011	34.3"		43		**3/4"-10 UNC Locknut	4
	67249-009	34.5"		44		**5/8"-11 UNC x 6" Lower Shock Bolt	4
	67249-023	34.8"		45		**5/8" Flat Washer	8
	67249-017	35.0"		46		**5/8"-11 UNC Locknut	4
15	69565-001	<b>U-beam Assembly Enhancement Aftermarket Service Kit, Axle Set, See Page 3 for contents</b>		47	64508-XXX	S-cam Support Bracket <i>See Part No. on component</i>	4
		<b>Single D-Pin Bushing Service Kit,</b> Includes Key Nos. 16, 17a, 18-19				<b>S-cam Fastener Service Kit, Axle Set,</b> Includes Key Nos. 48-53	
	34013-107	Includes Key Nos. 16, 17b, 18-19		48		**3/8"-16 UNC x 1 1/4" Hex Bolt	8
	34013-116	Includes Key Nos. 16, 17c, 18-19		49		**3/8" Hardened Washer	16
	34013-117			50		**3/8"-16 UNC Locknut	8
16		**D-Pin Bushing	4	51		**5/16" S-cam U-bolt	4
		<b>D-Pin Fastener Service Kit, Axle Set,</b> Includes Key Nos. 17a, 18-19		52		**5/16" Hardened Washer	16
	56659-009	Includes Key Nos. 17b, 18-19		53		**9/16"-18 UNC Locknut	8
	56659-013	Includes Key Nos. 17c, 18-19		54	70867-001	P-80 Lubricant - 10 ml (Not Shown)	per Bushing 1
	56659-012						
17		**3/4"-16 UNF Bolt	8				
a		5" Length					
b		5 1/2" Length					
c		4 3/4" Length					
18		**3/4" Flat Washer	16				
19		**3/4"-16 UNF Locknut	8				



9" Ride Height

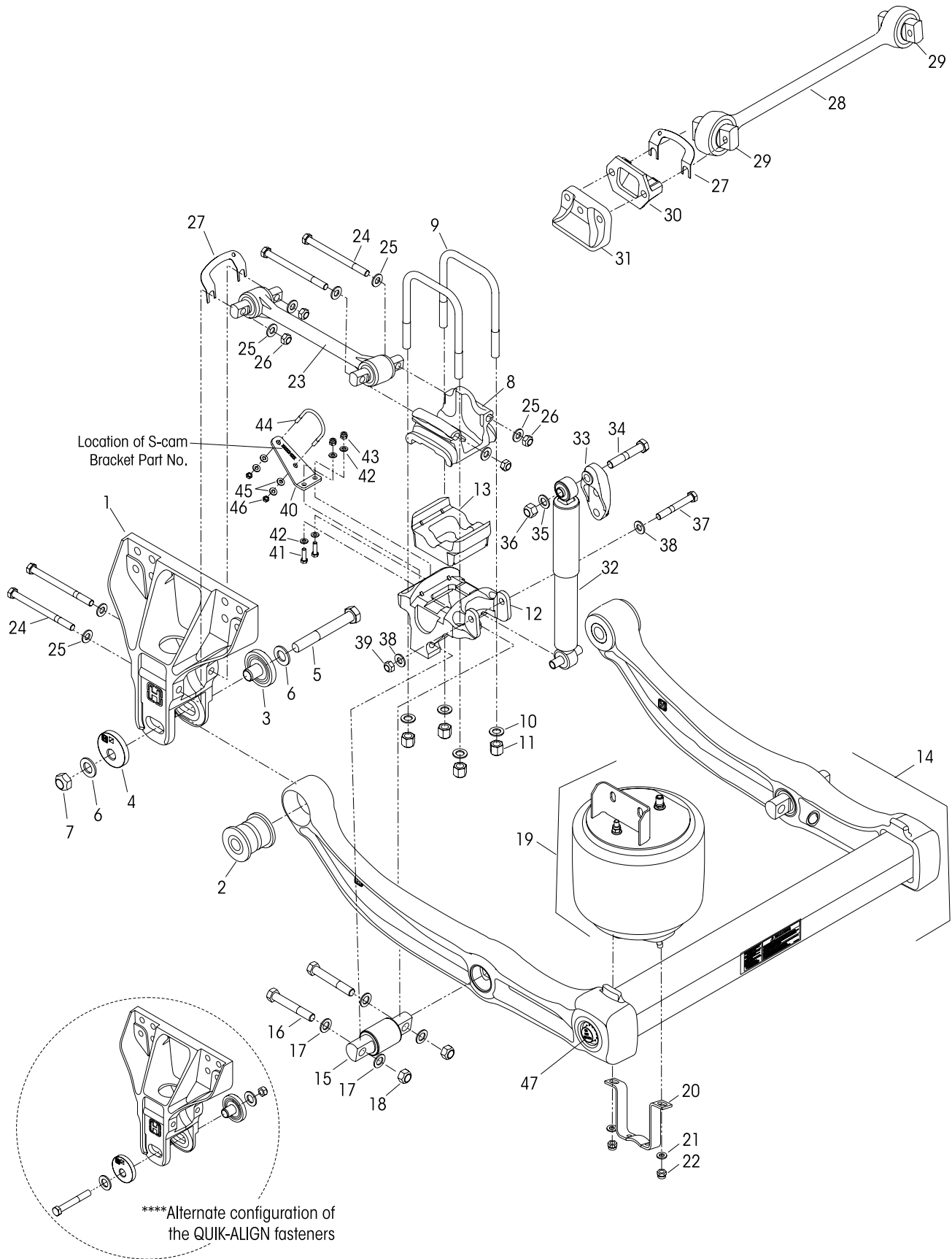





# PRIMAAX® EX 26K for Caterpillar Vehicles

KEY NO.	PART NO.	DESCRIPTION	*VEHICLE QTY.	KEY NO.	PART NO.	DESCRIPTION	*VEHICLE QTY.
1	67706-000	Frame Hanger	2		49177-006	<b>Lower Air Spring Fastener Service Kit, Single,</b> Includes Key Nos. 21-22	
	60961-720	One Wheel End		21		**1/2" Flat Washer	4
	60632-020	Axle Set		22		**1/2"-13 UNC Locknut	4
	60632-019	<b>QUIK-ALIGN Collar Service Kit,</b> Includes Key Nos. 3-7 One Wheel End, <i>Replaces 60632-006</i>			69361-031A	LH	1
	60632-021	Axle Set			69361-032B	RH	1
	60632-018	<b>QUIK-ALIGN Fastener Service Kit, One Wheel End,</b> Includes Key Nos. 5-7, <i>Replaces 60632-005</i>		23	62043-430N	Longitudinal Torque Rod Assembly	2
2		**Pivot Bushing	2			<b>Single Longitudinal Torque Rod Fastener Kit</b> 2-Bar Pin Connections, Includes Key Nos. 24-26	
3		**Concentric Collar	2		49176-032	2-Bar Pin Connections, Includes Key Nos. 24-26	
4		**Eccentric Collar	2	24		**5/8"-11 UNF x 8" Hex Bolt	8
5		**1"-14 UNF-2A x 7 1/2" H-Coat Hex Bolt	2	25		**5/8" Flat Washer	16
6		**1" H-Coat Flat Washer	4	26		**5/8"-11 UNC Locknut	8
7		**1"-14 UNF-2B H-Coat Locknut	2	27	49689-000L	Shim	As Req.
8	65289-000	Top Pad	2	28	72000-XXXS	***ULTRA ROD® PLUS™ Transverse Torque Rod Assembly, Includes Key No. 29, Specify length in mm	1
	48718-130	<b>U-bolt Service Kit, One Wheel End,</b> Includes Key Nos. 9-11		29	64400-002L	Bushing - Straddle Bar Pin (5/8" Holes)	2
9		**3/4" Square U-bolt, 10 3/8" Length	4	30	22186-000	Transverse Torque Rod Frame Bracket	1
10		**3/4" Flat Washer	8	31	60593-000	Axle Stop, Frame Mounted	2
11		**3/4"-16 UNF U-bolt Locknut	8	32	60665-011	Shock Absorber	2
12	60556-030	Bottom Cap	2	33	67463-002	Upper Shock Frame Bracket	2
13	65139-003	Axle Spacer	2		50754-029	<b>Single Shock Fastener Service Kit,</b> Includes Key Nos. 34-39	
14		U-beam Assembly, Includes Key Nos. 2, 15 Frame Width	2	34		**3/4"-10 UNC x 4 1/4" Upper Shock Bolt	2
	67249-004	34.0"		35		**3/4" Flat Washer	2
	67249-012	34.3"		36		**3/4"-10 UNC Locknut	2
	67249-010	34.5"		37		**5/8"-11 UNC x 7" Lower Shock Bolt	2
	67249-024	34.8"		38		**5/8" Flat Washer	4
	34013-107	<b>Single D-Pin Bushing Service Kit,</b> Includes Key Nos. 15-18		39		**5/8"-11 UNC Locknut	2
15		**D-Pin Bushing	2	40	64508-XXX	S-cam Support Bracket <i>See Part No. on component</i>	2
	56659-009	<b>D-Pin Fastener Service Kit, Axle Set</b> Includes Key Nos. 16-18			58821-017	<b>S-cam Fastener Service Kit, Axle Set,</b> Includes Key Nos. 41-46	
16		**3/4"-16 UNF x 5" Bolt	4	41		**3/8"-16 UNC x 1 1/4" Hex Bolt	4
17		**3/4" Flat Washer	8	42		**3/8" Hardened Washer	8
18		**3/4"-16 UNF Locknut	4	43		**3/8"-16 UNC Locknut	4
	60961-665	<b>Single Air Spring Service Kit,</b> Includes Key Nos. 19-22		44		**5/16" S-cam U-bolt	2
19	68056-002L	Air Spring Assembly, Includes Upper Frame Bracket and Fasteners	2	45		**5/16" Hardened Washer	8
20	60911-002	Lower Air Spring Mounting Bracket	2	46		**5/16"-18 UNC Locknut	4
				47	69565-001	<b>U-beam Assembly Enhancement Aftermarket Service Kit, Axle Set, See Page 3 for contents</b>	
				48	70867-001	P-80 Lubricant - 10 ml (Not Shown) per Bushing	1



### Severe Service Kits

<p><b>Severe Service Kit</b> <b>No. 60632-033</b>   QUIK-ALIGN Pivot Bushing Axle Set</p> <p>Reference Lit. No. 59310-037</p>	<p><b>KIT NO. 60632-033</b> <b>9", 10½", 13" Ride Height</b></p> <table border="1"> <thead> <tr> <th>KEY NO.</th> <th>CONTENTS</th> <th>KIT QTY.</th> </tr> </thead> <tbody> <tr> <td>1</td> <td>QUIK-ALIGN Concentric Collar</td> <td>2</td> </tr> <tr> <td>2</td> <td>QUIK-ALIGN Eccentric Collar</td> <td>2</td> </tr> <tr> <td>3</td> <td>1¼"-12 UNF Bolt - 8"</td> <td>2</td> </tr> <tr> <td>4</td> <td>1¼" Hardened Washer</td> <td>4</td> </tr> <tr> <td>5</td> <td>1¼"-12 UNF Nylocknut</td> <td>2</td> </tr> <tr> <td>6</td> <td>QUIK-ALIGN Pivot Bushing</td> <td>2</td> </tr> <tr> <td>7</td> <td>P-80 Bushing Lubricant - 10 ml.</td> <td>per Bushing 1</td> </tr> </tbody> </table>	KEY NO.	CONTENTS	KIT QTY.	1	QUIK-ALIGN Concentric Collar	2	2	QUIK-ALIGN Eccentric Collar	2	3	1¼"-12 UNF Bolt - 8"	2	4	1¼" Hardened Washer	4	5	1¼"-12 UNF Nylocknut	2	6	QUIK-ALIGN Pivot Bushing	2	7	P-80 Bushing Lubricant - 10 ml.	per Bushing 1
KEY NO.	CONTENTS	KIT QTY.																							
1	QUIK-ALIGN Concentric Collar	2																							
2	QUIK-ALIGN Eccentric Collar	2																							
3	1¼"-12 UNF Bolt - 8"	2																							
4	1¼" Hardened Washer	4																							
5	1¼"-12 UNF Nylocknut	2																							
6	QUIK-ALIGN Pivot Bushing	2																							
7	P-80 Bushing Lubricant - 10 ml.	per Bushing 1																							
<p><b>Severe Service Kit</b> <b>No. 60632-015</b>   QUIK-ALIGN Collar Axle Set</p> <p>Reference Lit. No. 59310-037</p>	<p><b>KIT NO. 60632-015</b> <b>9", 10½", 13" Ride Height</b></p> <table border="1"> <thead> <tr> <th>KEY NO.</th> <th>CONTENTS</th> <th>KIT QTY.</th> </tr> </thead> <tbody> <tr> <td>1</td> <td>QUIK-ALIGN Concentric Collar</td> <td>2</td> </tr> <tr> <td>2</td> <td>QUIK-ALIGN Eccentric Collar</td> <td>2</td> </tr> <tr> <td>3</td> <td>1¼"-12 UNF Bolt - 8"</td> <td>2</td> </tr> <tr> <td>4</td> <td>1¼" Hardened Washer</td> <td>4</td> </tr> <tr> <td>5</td> <td>1¼"-12 UNF Nylocknut</td> <td>2</td> </tr> </tbody> </table>	KEY NO.	CONTENTS	KIT QTY.	1	QUIK-ALIGN Concentric Collar	2	2	QUIK-ALIGN Eccentric Collar	2	3	1¼"-12 UNF Bolt - 8"	2	4	1¼" Hardened Washer	4	5	1¼"-12 UNF Nylocknut	2						
KEY NO.	CONTENTS	KIT QTY.																							
1	QUIK-ALIGN Concentric Collar	2																							
2	QUIK-ALIGN Eccentric Collar	2																							
3	1¼"-12 UNF Bolt - 8"	2																							
4	1¼" Hardened Washer	4																							
5	1¼"-12 UNF Nylocknut	2																							
<p><b>Severe Service Kit</b> <b>No. 58821-026</b>   Top Pad Fasteners Axle Set</p> <p>Reference Lit. No. 59310-036</p>	<p><b>KIT NO. 58821-026</b> <b>Top Pad Thru Bolt Style Only</b> <b>Does not include Top Pad</b></p> <table border="1"> <thead> <tr> <th>KEY NO.</th> <th>CONTENTS</th> <th>KIT QTY.</th> </tr> </thead> <tbody> <tr> <td>1</td> <td>M24 x 3.0-6G H-coat Hex Bolt</td> <td>2</td> </tr> <tr> <td>2</td> <td>M24 Hardened Washer</td> <td>4</td> </tr> <tr> <td>3</td> <td>M24 x 3.0-6H Locknuts</td> <td>2</td> </tr> </tbody> </table>	KEY NO.	CONTENTS	KIT QTY.	1	M24 x 3.0-6G H-coat Hex Bolt	2	2	M24 Hardened Washer	4	3	M24 x 3.0-6H Locknuts	2												
KEY NO.	CONTENTS	KIT QTY.																							
1	M24 x 3.0-6G H-coat Hex Bolt	2																							
2	M24 Hardened Washer	4																							
3	M24 x 3.0-6H Locknuts	2																							

**NOTES:**

- \* Quantities specified are shown for tandem suspension. Adjust quantities for single or tridem suspensions. Quantities of service kit components may vary from amount shown in lists.
- \*\* Item included in assembly / kit only, part not sold separately.
- \*\*\* Transverse Rods are mandatory for the PRIMAAX EX suspensions regardless of axle spacing, see Literature No. 59310-004 and 59310-058 for more information.
- \*\*\*\* Alternate configuration of the QUIK-ALIGN fasteners. The locknuts located inboard will allow additional clearance for wider tires or tires with chains. Tightening is still required ONLY on the locknut.



### Special Tools

#### D-PIN / QUIK-ALIGN PIVOT BUSHING SERVICE TOOLS

Hendrickson Part No. 66086-202

OTC Part No. 4246 Visit [otctools.com](http://otctools.com)

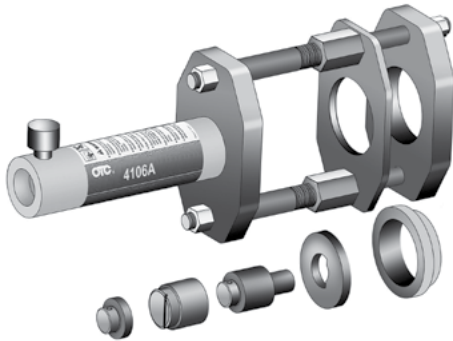

Hendrickson Part No. 66086-204

OTC Part No. 4247 Visit [otctools.com](http://otctools.com)

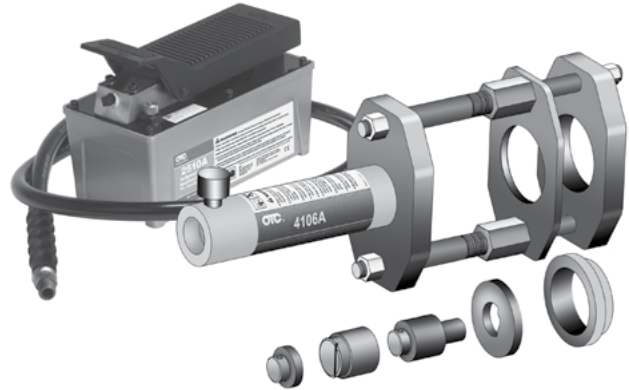

Hendrickson Part No. 66086-205

OTC Part No. 4254

Visit [otctools.com](http://otctools.com)

**NOTE:** In conjunction with Hendrickson Part No. 66086-204 (OTC 4247) this additional adapter tool kit is available to purchase to be used on Hendrickson SOFTEK NXT suspension (not needed for this suspension).

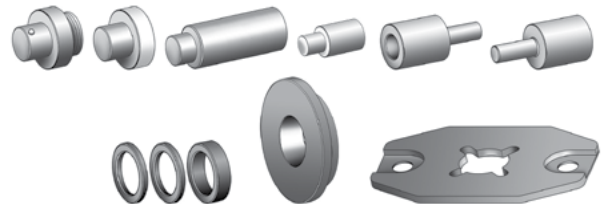

#### QUIK-ALIGN PIVOT BUSHING SERVICE TOOL

Hendrickson Part No. 66086-203L

Reference Literature No. 59310-061



#### QUIK-ALIGN SOCKET TOOL

Hendrickson Part No. 66086-200

OTC Part No. 1767

Visit [otctools.com](http://otctools.com)



#### TORQUE ROD BUSHING FUNNEL TOOL

ULTRA ROD

Hendrickson Part No. 66086-001L

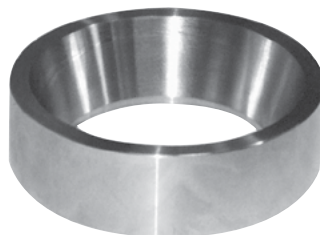

#### QUIK-WRENCH TOOL

Hendrickson Part No. 66086-201

OTC Part No. 1768

Visit [otctools.com](http://otctools.com)



This is a general parts list to provide directional information. Components may vary by model. Questions in regards to parts, contact Hendrickson Truck Parts at 1.866.755.5968 (Toll-free U.S. and Canada), 1.630.910.2800 (Outside U.S. and Canada) or e-mail: truckparts@hendrickson-intl.com.

---

[www.hendrickson-intl.com](http://www.hendrickson-intl.com)



Truck Commercial Vehicle Systems  
800 South Frontage Road  
Woodridge, IL 60517-4904 USA

1.866.755.5968 (Toll-free U.S. and Canada)  
1.630.910.2800 (Outside U.S. and Canada)  
Fax 1.630.910.2899