

H PRODUCT ANNOUNCEMENT

LC AUXILIARY AXLE CONTROL KITS

LIT NO: H830

DATE: April 2019

REVISION: A

Hendrickson Auxiliary Axle Systems announces the launch of our new LC Auxiliary Lift Axle Control Kits. The LC control kits are designed to accommodate a variety of lift axle applications and will replace the existing HAC auxiliary lift axle control kits. The new LC kits utilize diaphragm-operated valves, which eliminate the sticking that is common with spool valves like those used in the HAC controls. Diaphragm valves also outflow similar sized spool valves, resulting in quicker lift timing. The LC components have a long history of reliable service and are designed to survive the harsh truck and trailer environment with or without an enclosure. The table below shows the available models as categorized by the master control mounting location and the lift axle application. The LC auxiliary lift axle controls kits will be available for purchase beginning April 2019.

AVAILABLE MODELS

		INSIDE-MOUNTED	OUTSIDE-MOUNTED (COMPOSITE)	OUTSIDE-MOUNTED (STAINLESS)
LIFT AXLE APPLICATION	NON-STEERABLE	LC-NSI	LC-UCO	LC-USO
	STEERABLE	LC-SSI		
	REVERSE LIFT & LOCK	LC-LSI	LC-LCO	LC-LSO
	REVERSE DOWN & LOCK	LC-RSI	LC-RCO	LC-RSO
	REVERSE CASTER	LC-ASI	LC-ACO	LC-ASO

All LC kits come standard with one (1) one master control assembly, one (1) secondary (slave) assembly, and one (1) pressure protection valve for a single lift axle application. All outside-mounted kits also include an optional electric override switch. This switch can be installed in the cab to give the driver temporary override control without exiting the vehicle. Reverse kits include a reverse control assembly as well. The master control assembly should be mounted in the preferred location (inside vs. outside), and the secondary (slave) assembly should be mounted to the vehicle frame near the lift axle for optimal plumbing and lift timing. The LC kits noted in the table above are designed to re-deploy to match the state of the air toggle switch in the interior master or the push/pull knob in the exterior master when the vehicle is powered OFF.

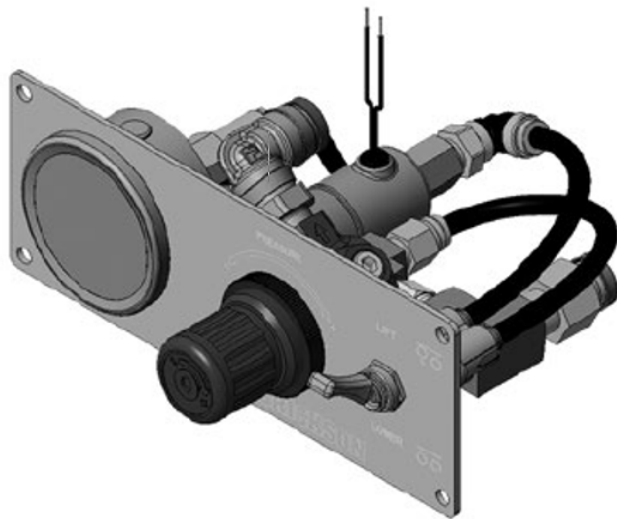

LC-SSI Master Control Assembly

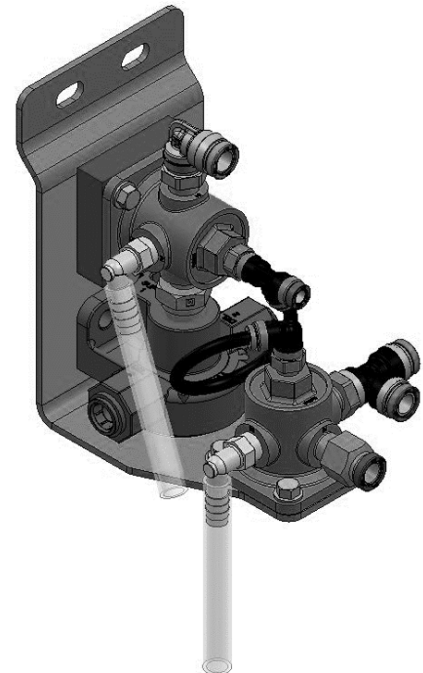

Secondary Slave Assembly

As an alternative to the models listed in the table, two additional LC kits are also available. Contact Hendrickson to determine if they are right for your application.

LC-MCA – For steerable and non-steer axles. An outside-mounted composite enclosure containing the valve assembly, regulator and gauge only. This kit does NOT include a push/pull valve. A separate electric override switch is intended to be mounted in the cab to control the state of the axle. LC-MCA is designed to lift the axle to the up position when the electric override switch (or vehicle) is powered OFF.

LC-MSO – For steerable and non-steer axles. An outside-mounted enclosure containing the valve assembly, regulator, gauge and an external valve stem. This kit does NOT include a push/pull valve. A separate electric override switch is intended to be mounted in the cab to control the state of the axle. LC-MSO is designed to lift the axle to the up position when the electric override switch (or vehicle) is powered OFF. This kit also meets the specific mounting requirements of the state of Maryland.

The LC auxiliary lift axle control kits feature color-coded connections, as was standard on the HAC kits (see example below). These color-coded caps provide for easy identification and reduced installation time.

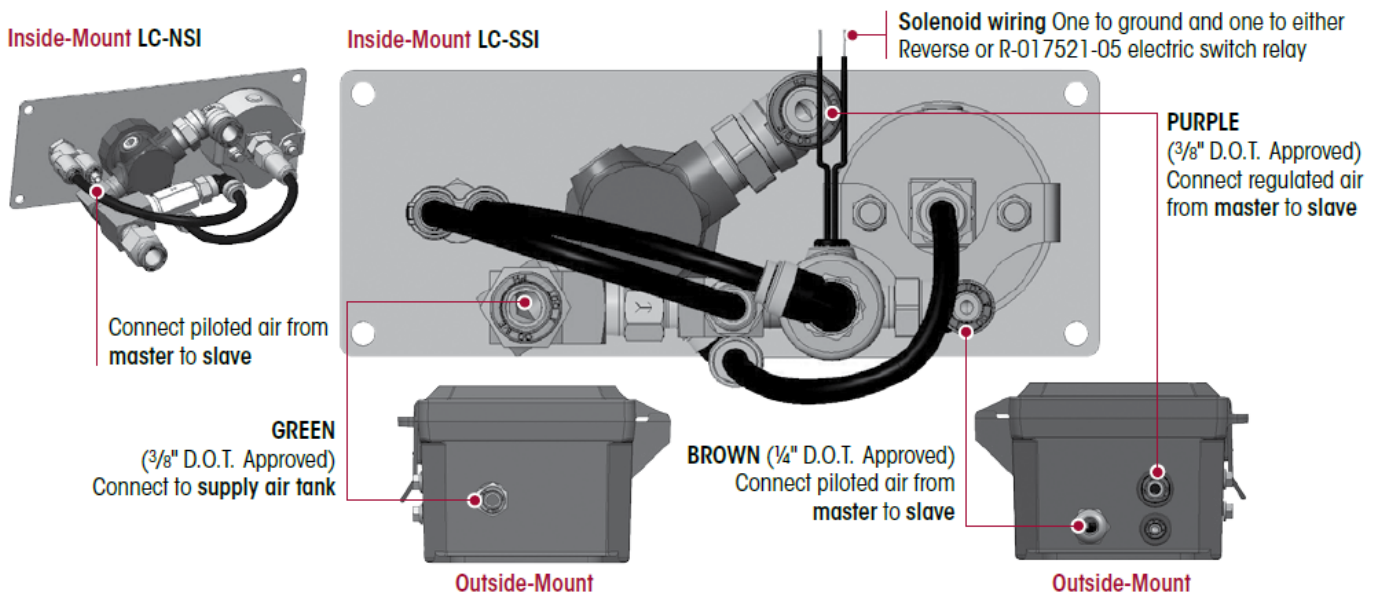

As always, Hendrickson is committed to providing world-class products and customer service. OM-H817 LC Auxiliary Lift Axle Control Kits Owner's Manual provides detailed installation and operation procedures, as well as a comprehensive replacement parts list for the LC kits. If you would like additional information, please contact your Hendrickson representative for further assistance.

Actual product performance may vary depending upon vehicle configuration, operation, service and other factors. All applications must comply with applicable Hendrickson specifications and must be approved by the respective vehicle manufacturer with the vehicle in its original, as-built configuration. Contact Hendrickson for additional details regarding specifications, applications, capacities, and operation, service and maintenance instructions.

Call Hendrickson at **800.660.2829** or **800.668.5360** in Canada for additional information.