

H PARTS LIST

VANTRAAX® HKAL 46K

LIT NO: L1080

DATE: June 2019

REVISION: D





SLIDER PINS

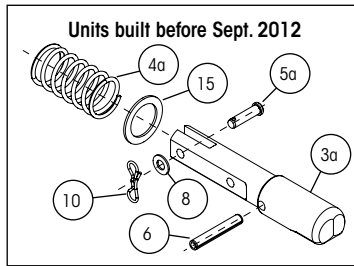
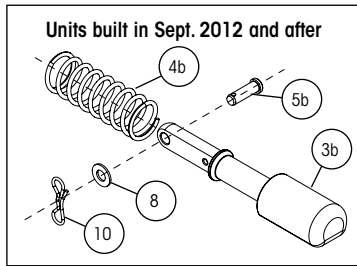

QUIK-DRAW® ACTUATOR ENDS

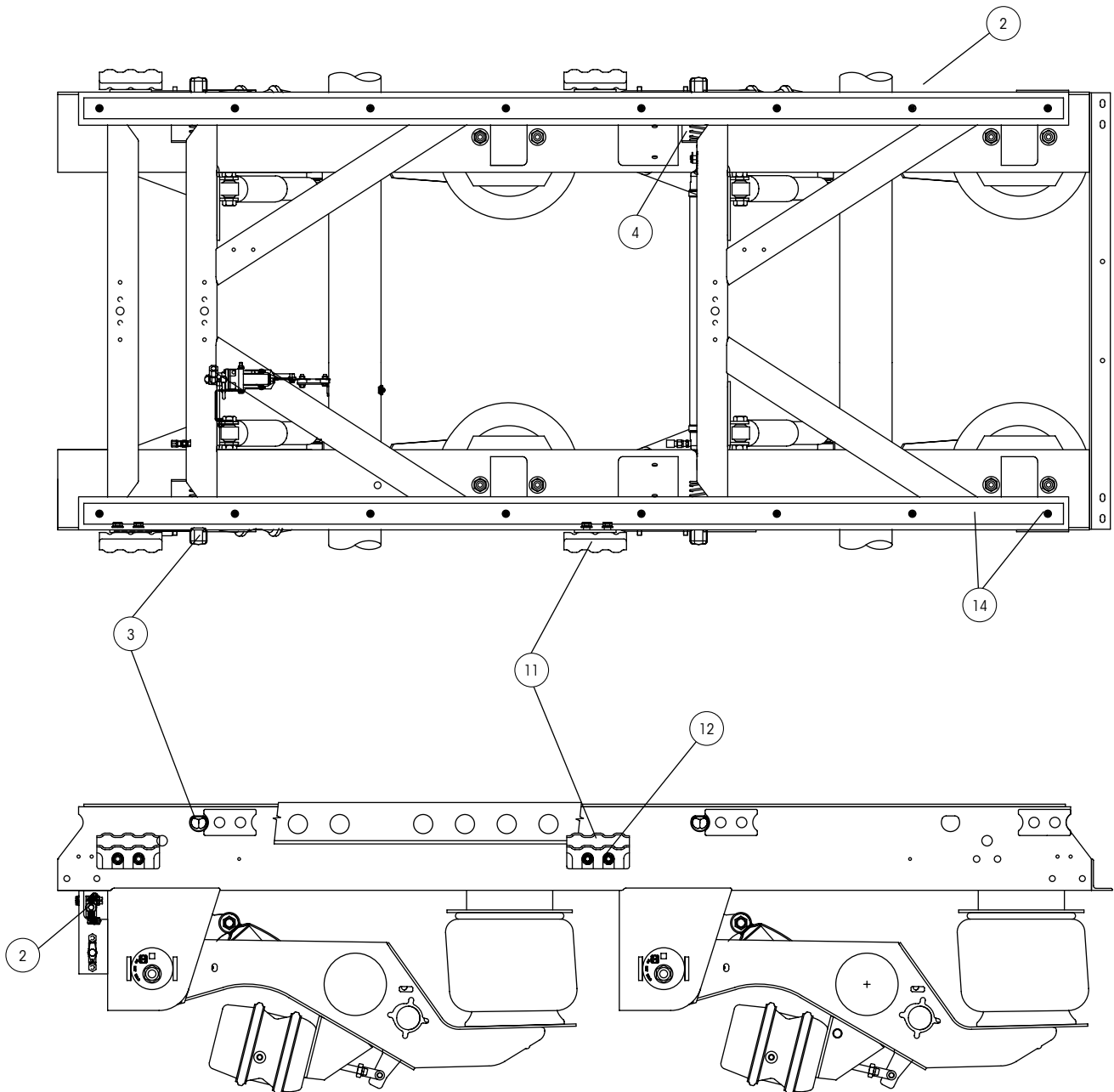
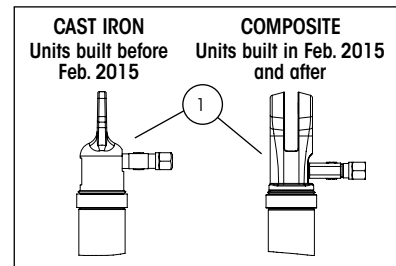

Note: Identification tag can be found on the roadside slider box rail above the front frame bracket. There will also be a blank INTRAAX® tag on the inside of the curbside beam.

**SLIDER BOX ASSEMBLY**

ITEM	DESCRIPTION	PART NO.	SYSTEM QTY.	NOTE
1	QUIK-DRAW[®] PNEUMATIC PIN-PULL MECHANISM			Refer to L751 - QUIK-DRAW Parts List
2	AFTERMARKET SLIDER BOX REPLACEMENT	AMBOX.###	1	Please contact Hendrickson for assistance
3a	LOCKING PIN (Units built before Sept. 2012)			
	1.375" diameter pin	S-28290	4	4" (TTMA) & 6" body rail hole spacing
	1.625" diameter pin	S-28289	4	4" body rail hole spacing
3b	LOCKING PIN (Units built in Sept. 2012 and after)			
	1.375" diameter pin	S-32389	4	4" (TTMA) & 6" body rail hole spacing
	1.625" diameter pin	S-32388	4	4" body rail hole spacing
4a	LOCKING PIN SPRING (Units built before Sept. 2012)			
	48" box with QUIK-DRAW	B-28930	4	3.25" spring
	42" box with QUIK-DRAW	B-22000	4	3.8" spring
4b	LOCKING PIN SPRING (Units built in Sept. 2012 and after)			
	42", 48" and 54" box with QUIK-DRAW	B-32500	4	4.5" spring
5a	CLEVIS PIN (Units built before Sept. 2012)	SA-5200-6	4	$\frac{3}{8}$ " \times $1\frac{3}{8}$ "
5b	CLEVIS PIN (Units built in Sept. 2012 and after)			
	Cast iron end	SA-5200-8	4	$\frac{3}{8}$ " \times 1.16"
	Composite end	SA-5200-10	4	$\frac{3}{8}$ " \times 1.82"
6	SPRING PIN (Units built before July 2014)	SA-8100-4	4	$\frac{3}{8}$ " \times $2\frac{1}{2}$ " roll pin
7	LOCKING PIN LINK (Not shown)			
	42" box	S-32967-1	2	
	48" box	S-32967-2	2	
	54" box	S-32967-3	2	
8	LOCKING PIN WASHER	SA-1500-2	6	$\frac{3}{8}$ " I.D. flat washer
9	PIN WASHER (Units built before July 2014)	S-30641	1	
10	LOCKING COTTER PIN	SA-1700-12	6	$\frac{3}{32}$ " \times 1" cotter pin
11	BODY RAIL CLIP			
	11a 3.4" clip height	S-24459	4	Use with 1.625" locking pin and 4" body rail hole spacing or 1.375" locking pin and 4" body rail hole spacing (TTMA)
	11b 3.8" clip height	S-24460	4	Use with 1.375" locking pin and 6" body rail hole spacing
12	BODY RAIL BOLT	SA-6900-2	8	$\frac{1}{2}$ "-13 \times $1\frac{1}{2}$ " flanged bolt
13	BODY RAIL CLIP SPACER (Not shown)	A-22367	4	2" clip hole centers
14	SLIDER WEAR PAD KIT	S-14342-3	2	Includes (1) slider wear pad and hardware

Note: Narrow hanger shown. Pin pull mechanisms are identical for both wide and narrow width slider models.

Note: Identification tag can be found on the roadside slider box rail above the front frame bracket. There will also be a blank INTRAAX[®] tag on the inside of the curbside beam.

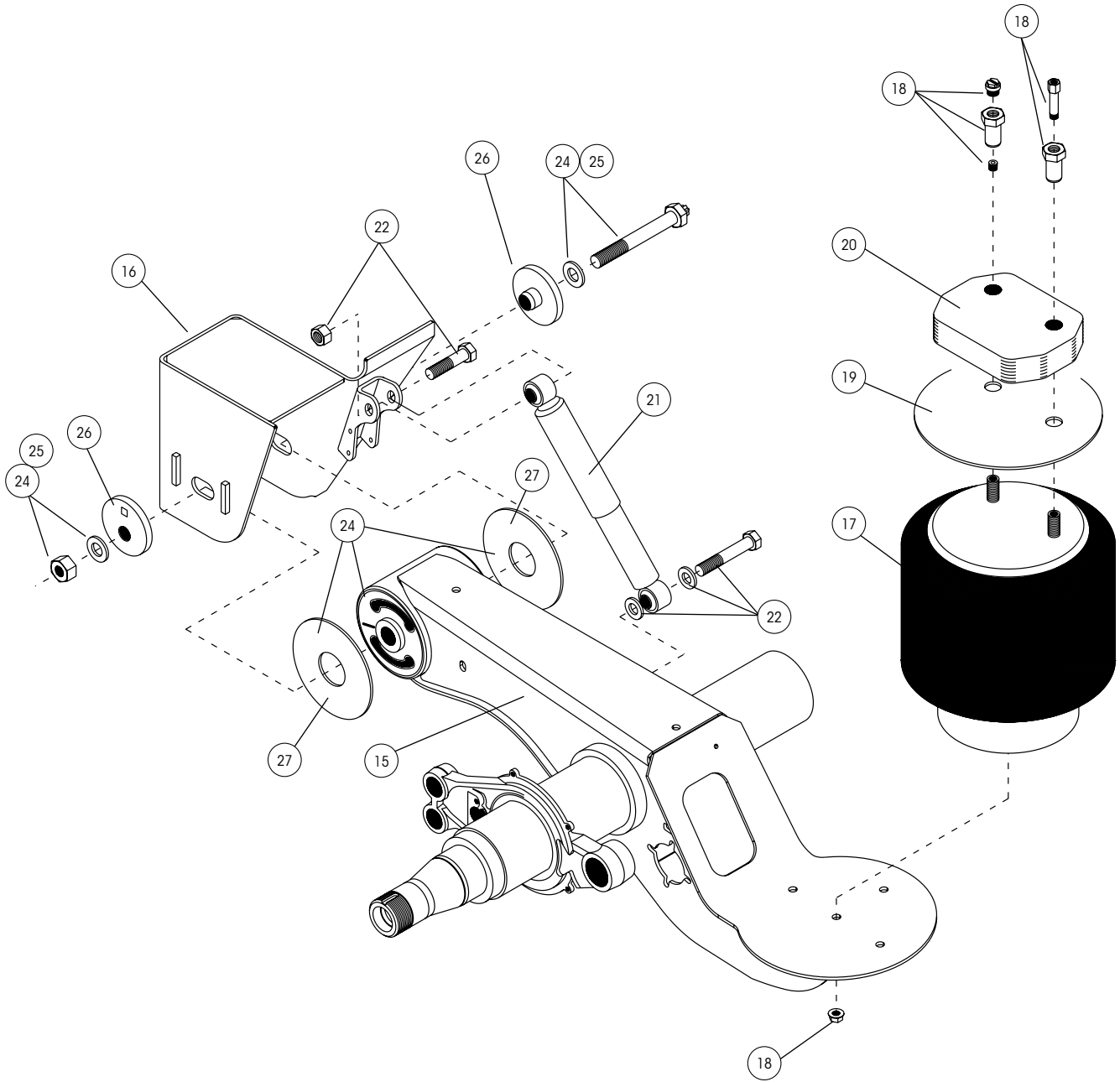

Note: Identification tag can be found on the roadside slider box rail above the front frame bracket. There will also be a blank INTRAAX® tag on the inside of the curbside beam.

**SUSPENSION ASSEMBLIES**

ITEM	DESCRIPTION	PART NO.	SYSTEM QTY.	NOTE
15	AXLE / BEAM WELDMENT	HTRAAX.###	2	Contact Hendrickson for assistance
16	FRAME BRACKET ASSEMBLY			
	Roadside	D-26067-1L	2	10" ride heights
	Curbside	D-26067-1R	2	10" ride heights
	Roadside	S-33173-2L	2	11" ride heights
	Curbside	S-33173-2R	2	11" ride heights
17	AIR SPRING	S-23613		
18	AIR SPRING MOUNTING KIT (per air spring)	S-22631/2	2	Includes Spiralock nuts, pipe plug and flange nut
19	AIR SPRING PLATE	S-23294	2	
20	UPPER AIR SPRING SPACER	B-22510-2		10" and 11" ride height (1.875" thick)
21	SHOCK ABSORBER	S-23566	4	Standard duty
22	SHOCK BOLT KIT (per shock)	S-24757/2	4	Includes shear bolt, spacer, washers, hex bolt and hex nut
23	SHOCK STRAP KIT (Not shown)	C-23086-1	4	Includes (2) straps, (2) clevis and (4) ties
24	TRI-FUNCTIONAL® PIVOT BUSHING KIT ¹	S-24691	2	Includes (1) bushings, (1) pivot bolt kits, (2) bushing tube spacers and lubricant pack
25	QUIK-ALIGN® PIVOT BOLT KIT	S-24679	2	Contains 10" bolt, nut and hardened washers
26	ALIGNMENT COLLAR			
	26a Concentric	S-20924	4	Pivot bolt hole is centered
	26b Eccentric	S-20925	4	Pivot bolt hole is offset from center
27	BUSHING TUBE SPACER	S-21099		

OTHER PARTS LISTS

More information can be found in the following documents

Lit. Number	Description
L751	QUIK-DRAW® Parts List
L1055	SURELOK® Parts List

1. Bushing tool S-21307 is required to properly re-bush the suspension.

Note: Identification tag can be found on the roadside slider box rail above the front frame bracket. There will also be a blank INTRAAX® tag on the inside of the curbside beam.

*Actual product performance may vary depending upon vehicle configuration, operation, service and other factors.
All applications must comply with applicable Hendrickson specifications and must be approved by the respective vehicle manufacturer with the vehicle in its original, as-built configuration.
Contact Hendrickson for additional details regarding specifications, applications, capacities, and operation, service and maintenance instructions.*

Call Hendrickson at 330.489.0045 or 866.RIDEAIR (743.3247) for additional information.



www.hendrickson-intl.com

TRAILER COMMERCIAL VEHICLE SYSTEMS

2070 Industrial Place SE
Canton, OH 44707-2641 USA
866.RIDEAIR (743.3247)
330.489.0045 • Fax 800.696.4416

Hendrickson Canada

250 Chrysler Drive, Unit #3
Brampton, ON Canada L6S 6B6
800.668.5360
905.789.1030 • Fax 905.789.1033

Hendrickson Mexicana

Circuito El Marqués Sur #29
Parque Industrial El Marqués
Pob. El Colorado, Municipio El Marqués,
Querétaro, México C.P. 76246
+52 (442) 296.3600 • Fax +52 (442) 296.3601

L1080 Rev D 06-19

© 2008 – 2019 Hendrickson USA, L.L.C. All Rights Reserved. All trademarks shown are owned by Hendrickson USA, L.L.C., or one of its affiliates, in one or more countries.
Information contained in this literature was accurate at the time of publication. Product changes may have been made after the copyright date that are not reflected.

Printed in United States of America