

H TECHNICAL PROCEDURE

HTB® 175M Mechanical Rear Suspension for Workhorse UFO Motorhome Chassis

SUBJECT: Service Instructions

LIT NO: 17730-256

DATE: September 2014 **REVISION:** B

TABLE OF CONTENTS

Section 1	Introduction	2	Section 8	Component Replacement	24
Section 2	Product Description	2	Suspension Overview	24	
Section 3	Important Safety Notice	4	Fasteners	24	
Section 4	Parts List	8	Shock Absorber	24	
Section 5	Special Tools	10	Coil Spring	26	
Section 6	Preventive Maintenance	11	Coil Spring Hanger	28	
	Component Inspection	11	Frame Hanger	28	
	U-bolts	12	Longitudinal Torque Rod	29	
	Axle Brackets	12	Torque Rod Bushing	31	
	Longitudinal Torque Rods	13	Torque Box	33	
	Shock Absorber Inspection	14	Clamp Group (Top Pad, Lower Coil Spring Bracket, U-bolts)	36	
Section 7	Alignment & Adjustments	16	Auxiliary Bumper	39	
	Checking and Correcting Axle Alignment . .	16	Cross Member	39	
	Pinion Angle	22	Section 9	Troubleshooting Guide	41
			Section 10	Torque Specifications	42



SECTION 1

Introduction

This publication is intended to acquaint and assist maintenance personnel in the preventive maintenance, service, repair and rebuild of the HTB® Mechanical suspension system as installed on applicable Workhorse UFO motorhome.

NOTE

Use only Genuine  Hendrickson parts for servicing this suspension system.

It is important to read and understand the entire Technical Procedure publication prior to performing any maintenance, service, repair, or rebuild of this product. The information in this publication contains parts lists, safety information, product specifications, features, proper maintenance, service, repair and rebuild instructions for the HTB Mechanical Suspension.

Hendrickson reserves the right to make changes and improvements to its products and publications at any time. Contact Hendrickson Tech Services for information on the latest version of this manual at 1-866-755-5968 (toll-free U.S. and Canada), 1-630-910-2800 (outside U.S. and Canada) or e-mail: techservices@hendrickson-intl.com.

The latest revision of this publication is also available online at www.hendrickson-intl.com.

SECTION 2

Product Description

The **HTB® 175M** — Lightweight, non-torque reactive mechanical rear suspension system combines superior ride, improved stability and reduced maintenance. Unique design and components make the HTB 175M reliable and rugged.

- **Axle alignment** — The torque box, torque rods and clamp group joints provide consistent axle alignment and reduce the need for realignment.
- **Coil springs** — HTB Mechanical Suspension has a highly optimized motion ratio since the coil spring and axle travel at the same rate.
- **Rubber bushings** — All pivot points come equipped with premium rubber bushings eliminating the need for lubrication. Torque box bushings are designed for long life.
- **Torque box** — HTB Mechanical Suspension's unique, maintenance-free torque box system improves multi-axial stability and control. The parallelogram design controls suspension windup and corresponding frame rise. Maintaining pinion angles throughout axle travel reduces suspension-induced driveline vibration and extends driveline component life.
- **U-bolts** — Re-torque of the clamp group is reduced since no twisting is applied to the clamp group.



**FIGURE 2-1
LIGHTWEIGHT, NON-TORQUE REACTIVE MECHANICAL REAR SUSPENSION**

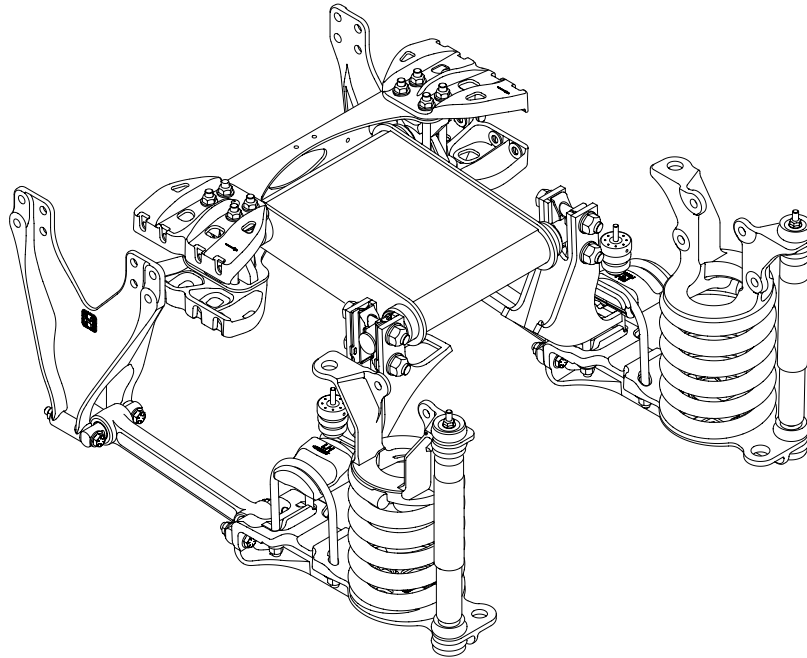

HTB® 175M SPECIFICATIONS¹

	HTB 175M
Capacity	17,500 pounds
Installed Weight	530 pounds
On-highway Rating	100%
Axle Configuration	Single
GVW Approval	26,000 pounds
GCW Approval	30,000 pounds
Ride Heights	8.625" ± 0.139"
Engine Torque Restrictions	None
Applications²	
RV	Yes
Motorhome	Yes

1. Actual product performance may vary depending upon vehicle configuration, operation, service and other factors. All applications must comply with applicable Hendrickson specifications and must also be approved by the respective vehicle manufacturer with the vehicle in its original, as-built configuration. Contact Hendrickson and the respective vehicle manufacturer for approval of additional applications.
2. These are indicative of typical applications. Please contact your dealer or a Hendrickson service representative before using suspension on other applications.

SECTION 3

Important Safety Notice

Proper maintenance, service and repair is important to the reliable operation of the suspension. The procedures recommended by Hendrickson and described in this technical publication are methods of performing such maintenance, service and repair.

The warnings and cautions should be read carefully to help prevent personal injury and to assure that proper methods are used. Improper maintenance, service or repair may damage the vehicle, cause personal injury, render it unsafe in operation, or void manufacturer's warranty.

Failure to follow the safety precautions in this manual can result in personal injury and/or property damage. Carefully read and understand all safety related information within this publication, on all decals and that provided by the vehicle manufacturer before conducting any maintenance, service or repair.

■ EXPLANATION OF SIGNAL WORDS

Hazard "Signal Words" (Danger-Warning-Caution) appear in various locations throughout this publication. Information accented by one of these signal words must be observed to help minimize the risk of personal injury to service personnel, or possibility of improper service methods which may damage the vehicle or render it unsafe.



This is the safety alert symbol. It is used to alert you to potential personal injury hazards. Obey all safety messages that follow this symbol to avoid possible injury or death.

Additional 'Notes' or 'Service Hints' are utilized to emphasize areas of procedural importance and provide suggestions for ease of repair. The following definitions indicate the use of these signal words as they appear throughout the publication.



INDICATES AN IMMINENTLY HAZARDOUS SITUATION, WHICH, IF NOT AVOIDED, WILL RESULT IN SERIOUS INJURY OR DEATH.



INDICATES A POTENTIAL HAZARDOUS SITUATION WHICH, IF NOT AVOIDED, CAN RESULT IN SERIOUS INJURY OR DEATH.



INDICATES A POTENTIAL HAZARDOUS SITUATION WHICH, IF NOT AVOIDED, MAY RESULT IN MINOR OR MODERATE INJURY.

NOTE

An operating procedure, practice condition, etc. which is essential to emphasize.

SERVICE HINT

A helpful suggestion that will make the service being performed a little easier and/or faster.

Also, note that particular service operations may require the use of special tools designed for specific purposes. These special tools can be found in the Special Tools Section of this publication.



The torque symbol alerts you to tighten fasteners to a specified torque value. Refer to Torque Specifications Section of this publication.



■ SAFETY PRECAUTIONS



WARNING

FASTENERS

DISCARD USED FASTENERS. ALWAYS USE NEW FASTENERS TO COMPLETE A REPAIR. FAILURE TO DO SO COULD RESULT IN FAILURE OF THE PART, OR MATING COMPONENTS, LOSS OF VEHICLE CONTROL, PERSONAL INJURY, OR PROPERTY DAMAGE.

LOOSE OR OVER TORQUED FASTENERS CAN CAUSE COMPONENT DAMAGE, LOSS OF VEHICLE CONTROL, PROPERTY DAMAGE, OR SEVERE PERSONAL INJURY. MAINTAIN CORRECT TORQUE VALUE AT ALL TIMES. CHECK TORQUE VALUES ON A REGULAR BASIS AS SPECIFIED, USING A REGULARLY CALIBRATED TORQUE WRENCH. TORQUE VALUES SPECIFIED IN THIS TECHNICAL PUBLICATION ARE FOR HENDRICKSON SUPPLIED FASTENERS ONLY. IF NON HENDRICKSON FASTENERS ARE USED, FOLLOW TORQUE SPECIFICATION LISTED IN THE VEHICLE MANUFACTURER'S SERVICE MANUAL.



WARNING

LOAD CAPACITY

ADHERE TO THE PUBLISHED CAPACITY RATINGS FOR THE SUSPENSION. ADD-ON AXLE ATTACHMENTS AND OTHER LOAD TRANSFERRING DEVICES CAN INCREASE THE SUSPENSION LOAD ABOVE ITS RATED AND APPROVED CAPACITIES, WHICH CAN RESULT IN COMPONENT DAMAGE AND LOSS OF VEHICLE CONTROL, POSSIBLY CAUSING PERSONAL INJURY OR PROPERTY DAMAGE.



WARNING

TORCH/WELDING

DO NOT USE A CUTTING TORCH TO REMOVE ANY FASTENERS. THE USE OF HEAT ON SUSPENSION COMPONENTS WILL ADVERSELY AFFECT THE STRENGTH OF THESE PARTS. A COMPONENT DAMAGED IN THIS MANNER CAN RESULT IN THE LOSS OF VEHICLE CONTROL AND POSSIBLE PERSONAL INJURY OR PROPERTY DAMAGE.

EXERCISE EXTREME CARE WHEN HANDLING OR PERFORMING MAINTENANCE IN THE AREA OF THE EQUALIZING BEAM. DO NOT CONNECT ARC WELDING GROUND LINE TO THE EQUALIZING BEAM. DO NOT STRIKE AN ARC WITH THE ELECTRODE ON THE EQUALIZING BEAM AND AXLE. DO NOT USE HEAT NEAR THE EQUALIZING BEAM ASSEMBLY. DO NOT NICK OR GOUGE THE EQUALIZING BEAM. SUCH IMPROPER ACTIONS CAN DAMAGE THE EQUALIZING BEAM ASSEMBLY, AND CAN CAUSE LOSS OF VEHICLE CONTROL AND POSSIBLE PERSONAL INJURY OR PROPERTY DAMAGE.



WARNING

MODIFYING COMPONENTS

DO NOT MODIFY OR REWORK PARTS WITHOUT AUTHORIZATION FROM HENDRICKSON. DO NOT SUBSTITUTE REPLACEMENT COMPONENTS NOT AUTHORIZED BY HENDRICKSON. USE OF MODIFIED, REWORKED, SUBSTITUTE OR REPLACEMENT PARTS NOT AUTHORIZED BY HENDRICKSON MAY NOT MEET HENDRICKSON'S SPECIFICATIONS, AND CAN RESULT IN FAILURE OF THE PART, LOSS OF VEHICLE CONTROL, POSSIBLE PERSONAL INJURY OR PROPERTY DAMAGE, AND WILL VOID ANY APPLICABLE WARRANTIES. USE ONLY HENDRICKSON AUTHORIZED REPLACEMENT PARTS.



CAUTION

PROCEDURES AND TOOLS

A TECHNICIAN USING A SERVICE PROCEDURE OR TOOL WHICH HAS NOT BEEN RECOMMENDED BY HENDRICKSON MUST FIRST SATISFY HIMSELF THAT NEITHER HIS/HER SAFETY NOR THE VEHICLE'S SAFETY WILL BE JEOPARDIZED BY THE METHOD OR TOOL SELECTED. INDIVIDUALS DEVIATING IN ANY MANNER FROM THE INSTRUCTIONS PROVIDED WILL ASSUME ALL RISKS OF CONSEQUENTIAL PERSONAL INJURY OR DAMAGE TO EQUIPMENT INVOLVED.



WARNING

JACKING METHODS

IMPROPER JACKING METHODS CAN RESULT IN LOSS OF WARRANTY, COMPONENT DAMAGE, VEHICLE DAMAGE, SEVERE PERSONAL INJURY, OR DEATH. ALWAYS CHOCK THE WHEELS OF THE VEHICLE TO PREVENT VEHICLE MOVEMENT. SUPPORT THE VEHICLE WITH SAFETY STANDS. NEVER WORK ON A VEHICLE SUPPORTED ONLY WITH A FLOOR JACK. REFER TO THE VEHICLE MANUFACTURER FOR PROPER JACKING INSTRUCTIONS.

 **WARNING****PERSONAL PROTECTIVE EQUIPMENT**

ALWAYS WEAR PROPER EYE PROTECTION AND OTHER REQUIRED PERSONAL PROTECTIVE EQUIPMENT TO HELP PREVENT PERSONAL INJURY WHEN PERFORMING VEHICLE MAINTENANCE, REPAIR OR SERVICE.

 **WARNING****TORQUE BOX CLAMP BOLTS**

IT IS IMPORTANT THAT THE TORQUE BOX CLAMP CONNECTIONS BE TIGHTENED IN THE PROPER SEQUENCE AND HAVE THE PROPER TORQUE VALUES MAINTAINED. FAILURE TO DO SO CAN RESULT IN THE DEFORMATION OF PARTS, RESULTING IN THE LOSS OF CLAMP FORCE, BOLT FAILURE, LOSS OF THE AXLE'S ALIGNMENT, LOSS OF VEHICLE CONTROL, PROPERTY DAMAGE, OR PERSONAL INJURY.

 **CAUTION**

THE TORQUE BOX CLAMP BOLTS, AT THE AXLE BRACKETS AND CROSS MEMBER, MUST BE TIGHTENED WHEN THE VEHICLE IS AT RIDE HEIGHT. TIGHTENING THE CLAMP BOLTS WHEN THE VEHICLE IS NOT AT RIDE HEIGHT WILL PRODUCE A TWIST IN THE TORQUE BOX BUSHINGS RESULTING IN PREMATURE COMPONENT WEAR OF THE TORQUE BOX BUSHINGS, IMPROPER RIDE HEIGHT OF THE VEHICLE AND ALTER RIDE QUALITY.

 **CAUTION****TORQUE BOX**

THE TORQUE BOX IS HEAVY (APPROXIMATELY 100 POUNDS). THE USE OF A LIFTING DEVICE IS REQUIRED FOR REMOVAL AND INSTALLATION OF THE TORQUE BOX. DO NOT ATTEMPT REMOVAL OR INSTALLATION WITHOUT THE PROPER EQUIPMENT.

 **WARNING****TORQUE BOX ALIGNMENT SHIMS**

THE DRIVE AXLE IS EQUIPPED WITH TWO SETS OF BAR PIN CLAMPS. ONE SET OF BAR PIN CLAMPS WILL BE ADJUSTABLE. THE OTHER SET OF BAR PIN CLAMPS MAY BE EITHER ADJUSTABLE OR NON-ADJUSTABLE. FOUR (4) AXLE BRACKET SHIMS MUST BE USED WITH THE ADJUSTABLE SET OF BAR PIN CLAMPS. THE NON-ADJUSTABLE BAR PIN CLAMPS DO NOT USE ANY AXLE BRACKET SHIMS. IF A PARTICULAR AXLE HAS ADJUSTABLE BAR PIN CLAMPS IN BOTH AXLE BRACKETS, THEN EIGHT (8) AXLE BRACKET SHIMS WILL BE USED (4 PER AXLE BRACKET). THE BAR PIN CLAMP PAIRS CAN BE CHANGED FROM SIDE TO SIDE BUT CANNOT BE MIXED. FAILURE TO PROPERLY INSTALL THE BAR PIN CLAMPS CAN RESULT IN THE DEFORMATION OF PARTS, LOSS OF CLAMP FORCE, BOLT FAILURE, LOSS OF THE AXLE'S ALIGNMENT, LOSS OF VEHICLE CONTROL, PROPERTY DAMAGE, OR PERSONAL INJURY.

 **WARNING****U-BOLT CLAMP GROUP CONNECTION**

IT IS IMPORTANT THAT THE U-BOLT CLAMP GROUP CONNECTION BE PROPERLY ALIGNED AND HAVE THE PROPER TORQUE VALUES MAINTAINED. METAL SURFACES CAN WORK AND WEAR AGAINST OTHER RELATED CLAMP GROUP COMPONENTS IF NOT PROPERLY ALIGNED OR PROPERLY TIGHTENED TO MAINTAIN THE PROPER CLAMP FORCE. FAILURE TO DO SO CAN CAUSE PREMATURE COMPONENT WEAR, POSSIBLE SEPARATION OF THE CLAMP GROUP, CAUSING LOSS OF VEHICLE CONTROL, PROPERTY DAMAGE, OR PERSONAL INJURY.

 **WARNING****LONGITUDINAL TORQUE ROD**

THE COIL SPRING TRANSFERS LOAD TO THE FRAME HANGER THROUGH THE LONGITUDINAL TORQUE ROD. PRIOR TO LONGITUDINAL TORQUE ROD REMOVAL THE COIL SPRING FORCE MUST BE NEUTRALIZED AS DETAILED IN THE LONGITUDINAL TORQUE ROD COMPONENT REPLACEMENT SECTION. FAILURE TO DO SO WILL CAUSE THE AXLE TO ROTATE AND/OR SHIFT, RESULTING IN POSSIBLE DAMAGE TO COMPONENTS AND/OR PERSONAL INJURY.



WARNING

SHOCK ABSORBERS

THE SHOCK ABSORBERS ARE THE REBOUND TRAVEL STOPS FOR THE SUSPENSION. ANYTIME THE AXLE ON A HTB MECHANICAL SUSPENSION IS SUSPENDED IT IS MANDATORY THAT THE SHOCK ABSORBERS REMAIN CONNECTED. FAILURE TO DO SO WILL RESULT IN OVER-EXTENSION OF THE SUSPENSION, CAUSING DAMAGE TO COMPONENTS. REPLACEMENT OF SHOCK ABSORBERS WITH NON-HENDRICKSON PARTS CAN ALTER THE REBOUND TRAVEL OF THE SUSPENSION.



WARNING

COIL SPRING STORED ENERGY

IMPROPER RESTRAINT OF COMPRESSED COIL SPRINGS CAN RESULT IN A VIOLENT SHIFT OF COMPONENTS, AND CAUSE SEVERE PERSONAL INJURY, DEATH AND/OR PROPERTY DAMAGE. FULLY DECOMPRESS OR SECURELY RESTRAIN COMPRESSED COIL SPRINGS BEFORE LOOSENING ANY CLAMP GROUP HARDWARE OR DISASSEMBLING ANY PART OF THE SUSPENSION SYSTEM. DO NOT OPERATE THE VEHICLE WITHOUT COIL SPRINGS PROPERLY INSTALLED AND RESTRICTED BY OTHER SUSPENSION COMPONENTS. SEE FURTHER INSTRUCTIONS AND DETAILS IN THIS PUBLICATION.



WARNING

PARTS CLEANING

SOLVENT CLEANERS CAN BE FLAMMABLE, POISONOUS, AND CAUSE BURNS. TO HELP AVOID SERIOUS PERSONAL INJURY, CAREFULLY FOLLOW THE MANUFACTURER'S PRODUCT INSTRUCTIONS AND GUIDELINES AND THE FOLLOWING PROCEDURES:

1. WEAR PROPER EYE PROTECTION.
2. WEAR CLOTHING THAT PROTECTS YOUR SKIN.
3. WORK IN A WELL-VENTILATED AREA.
4. DO NOT USE GASOLINE OR SOLVENTS THAT CONTAIN GASOLINE. GASOLINE CAN EXPLODE.
5. ACIDIC SOLUTIONS CANNOT BE USED ON ALUMINUM COMPONENTS.
6. HOT SOLUTION TANKS OR ALKALINE SOLUTIONS MUST BE USED CORRECTLY. FOLLOW THE MANUFACTURER'S RECOMMENDED INSTRUCTIONS AND GUIDELINES CAREFULLY TO HELP PREVENT PERSONAL ACCIDENT OR INJURY.

DO NOT USE HOT SOLUTION TANKS OR WATER AND ALKALINE SOLUTIONS TO CLEAN GROUND OR POLISHED PARTS. DOING SO WILL CAUSE DAMAGE TO THE PARTS AND VOID WARRANTY.

SECTION 4 Parts List

HTB® 175M for Workhorse UFO Motorhome Chassis

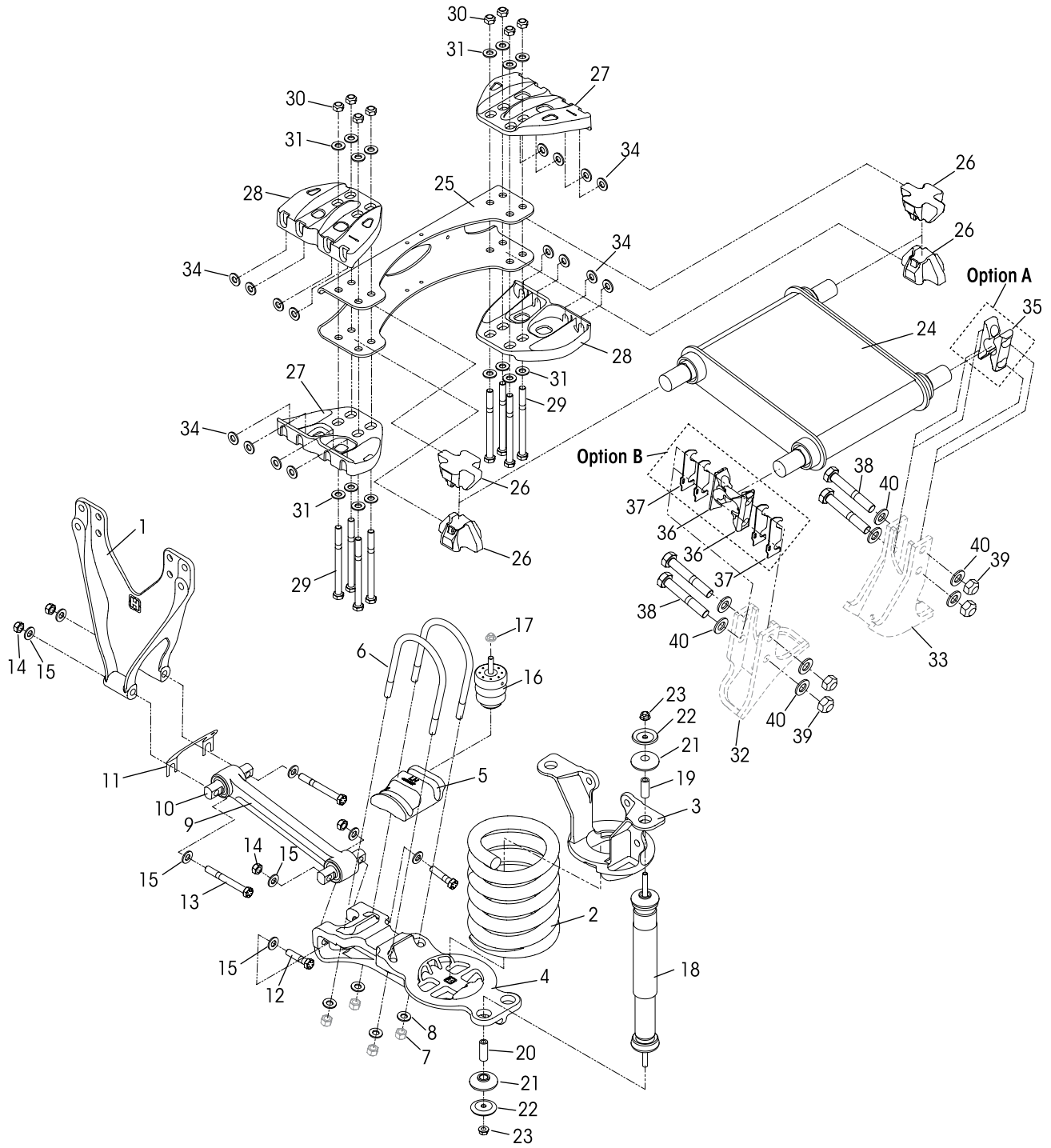



HTB® 175M for Workhorse UFO Motorhome Chassis

KEY NO.	PART NO.	DESCRIPTION	NO.REQ.	KEY NO.	PART NO.	DESCRIPTION	NO.REQ.
1	66512-000	Frame Hanger	2	20		**Lower Shock Spacer Length 2 ³ / ₁₆ "	2
2	66319-000	Coil Spring – 17.5K Pounds	2	21		**Rubber Isolator	4
3	66315-000	Coil Spring Hanger	2	22		**Retaining Washer	4
4	66317-000	Lower Coil Spring Bracket	2	23		**M12 Flange Locknut	4
5		Axle Top Pad		66513-002		Torque Box Cross Member Assembly, Includes Key Nos. 24-31	1
	66316-001	Left Hand	1	24	64785-005	Torque Box, Replaces 64785-004	1
	66316-002	Right Hand	1	25	64970-000	Cross Member C-Channel	1
	58821-022	Axle Clamp Fastener Kit, Axle Set, Includes Key Nos. 6-8		26	65144-000	Cross Member Bar Pin Clamp (Aluminum)	4
6	66323-000	5/8"-18 UNF U-bolt - 9.45"	4			Cross Member Gusset	
7		*5/8"-18 UNF U-bolt Tall Nut	8	27	66503-001	RH Top, LH Bottom	2
8	22962-004	5/8" Hardened Flat Washer	8	28	66503-002	LH Top, RH Bottom	2
9	48411-015	Torque Rod Assembly, Includes Key No.10	2	29	32043-016	5/8"-11 UNC Hex Bolt - 8.0"	8
10	47691-000	Torque Rod Bushing	4	30	47764-000	5/8"-11 UNC Locknut	8
11	57856-000	1/32" Torque Rod Shim (as required)	4	31	22962-004	5/8" Hardened Flat Washer	16
	49176-027	Torque Rod Fastener Kit, Axle Set, Includes Key Nos. 12-15		32		*Torque Box Axle Bracket - Dana (Short)	1
12	32043-002	5/8"-11 UNC Hex Bolt - 2.75"	4	33		*Torque Box Axle Bracket - Dana (Long)	1
13	32043-019	5/8"-11 UNC Hex Bolt - 5.5"	4	34	22962-004	5/8" Hardened Flat Washer	16
14	47764-000	5/8"-11 UNC Locknut	8	35	66174-000	Non-Adjustable Axle Bracket Bar Pin Clamp	2
15	22962-004	5/8" Hardened Flat Washer	16	36	66274-000	***Adjustable Axle Bracket Bar Pin Clamp	2
16	66308-001	Auxiliary Bumper	2	37	65737-001	***Axle Bracket Shims	4
17		*M10 Flanged Locknut	2	66027-002		Torque Box Axle Fastener Kit, Axle Set, Includes Key Nos. 38-40	
	60961-149	Shock Absorber Service Kit, One Side, Includes Key Nos. 18-23		38	58917-003	3/4"-10 UNC Hex Bolt - 5.5"	4
18		**Shock Absorber Assembly M12 Stud Mount, Includes Key Nos. 19-20	2	39	49842-000	3/4"-10 UNC Locknut	4
19		**Upper Shock Spacer Length 1 ⁵ / ₁₆ "	2	40	22962-001	3/4" Hardened Flat Washer	8
				Not Shown	70867-001	P-80 Lubricant - 10 ml.	per Bushing 1

NOTE:

* Not supplied by Hendrickson, used for reference only. Refer to vehicle manufacturer for more information. Hendrickson is not responsible for components supplied by vehicle manufacturer.

For assistance with maintenance and rebuild instructions on these components see vehicle manufacturer.

** Item included in assembly or service kit only, part not sold separately.

*** In the aftermarket, it is acceptable to replace the non-adjustable axle bracket bar pin clamp (Key No. 35) with the adjustable bar pin clamp plus and axle bracket shims (Key No. 36 and 37).

SECTION 5 Special Tools

TORQUE ROD BUSHING TOOLS

TORQUE ROD BUSHING ASSEMBLY TOOL (FUNNEL)

Contact your authorized Hendrickson distributor to order the bushing funnel tool, Hendrickson part number 66086-000.



TORQUE ROD BUSHING RECEIVING TOOL

This shop made tool is designed for the torque rod bushing replacement. Bushing tools are made from cold rolled steel or equivalent. Drawing is for reference only.

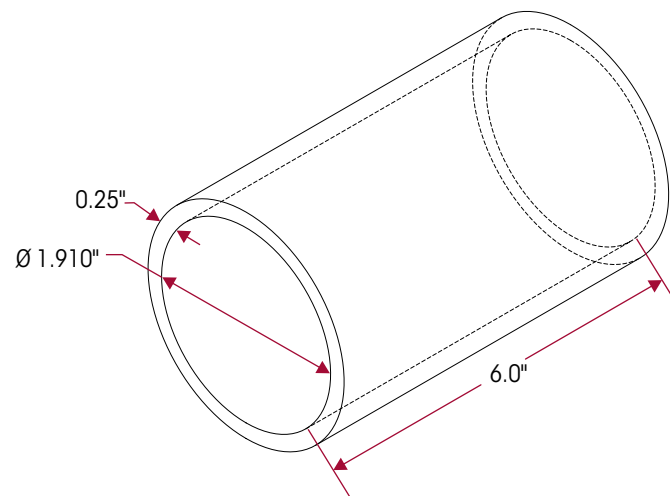



SECTION 6

Preventive Maintenance

Following appropriate inspection procedures is important to help ensure the proper maintenance and operation of the HTB® 175M suspension system and component parts function to their highest efficiency. Look for bent or cracked parts. Replace all worn or damaged parts.

HENDRICKSON RECOMMENDED PREVENTIVE MAINTENANCE INTERVALS

- **On-highway** – every 10,000 miles or annually, whichever comes first

COMPONENT INSPECTION

- **Auxiliary bumper** — Inspect for cracks or missing auxiliary bumper. Check fasteners for proper torque. Replace if necessary, see Component Replacement Section of this publication for replacement procedure.
- **Clamp group** — Clamp group includes U-bolts, top pad, and lower coil spring bracket. Look for any loose or damaged fasteners. Make sure the U-bolt clamp group connection is properly aligned and have the proper torque values maintained. See Torque Specifications Section of this publication.
- **Coil spring** — Inspect coil springs for any signs of coil spring or component damage. Check for any lateral slippage at the lower coil spring bracket. Slippage of 1/8" in either direction is acceptable. Ensure the open end of the coil spring is tight against the coil spring hanger.
- **Coil spring hanger** — Check the overall condition of the coil spring hanger. Inspect the coil spring hanger for any signs of loosening or damage.
- **Cross member and gussets** — Inspect the cross member and gussets for any signs of loosening or damage. Inspect the bar pin clamps for any signs of looseness or movement. Check all fasteners for proper torque.
- **Fasteners** — Look for any loose, missing or damaged fasteners on the entire suspension. Make sure all fasteners are tightened to a torque value within the specified torque range. See Torque Specifications Section of this publication for Hendrickson recommended torque requirements. Use a calibrated torque wrench to check torque in the tightening direction. As soon as the fastener starts to move, record the torque. Correct the torque if necessary.

NOTE

Hendrickson recommends the use of Grade 8 bolts, Grade C locknuts and hardened flat washers for all suspension component attachments.

- **Frame hanger** — Inspect the frame hanger for any signs of loosening or damage. Inspect all fasteners securing the frame hanger to the frame rails as well as the longitudinal torque rod mounting fasteners. Check all fasteners for proper torque.
- **Shock absorbers** — Look for any signs of dents or leakage. Misting is not considered a leak. See Shock Absorber Inspection in this section.
- **Tire wear** — Inspect the tires for wear patterns that may indicate suspension damage or misalignment. Replace all worn or damaged parts. Verify proper alignment and correct as necessary.
- **Torque box** — It is important to inspect the torque box during preventive maintenance service. Visually inspect the torque box for cracks, damage, torn or shredded rubber, or any signs of looseness at the bar pin clamps. Replace all worn or damaged parts. The torque box is a non-serviceable item and must be replaced as an assembly, if damaged, or the bushings are worn out. Maintain all fasteners at the proper torque, see Torque Specifications Section of this publication.
- **Wear and damage** — Inspect all parts of the suspension for wear and damage. Look for bent or cracked parts.

See vehicle manufacturer's applicable publications for other preventive maintenance requirements.

U-BOLTS

1. U-bolts must be torqued to specification at preparation for delivery.
2. U-bolts must be re-torqued at 500 miles or first service interval.
3. Thereafter, follow annually or 10,000 mile inspection and re-torque interval.

NOTE

Current Hendrickson Truck Suspension Systems U-bolt clamp group hardware for the HTB Mechanical suspension consist of phosphate and oil coated $\frac{5}{8}$ "-18 UNF Grade 8 U-bolts, $\frac{5}{8}$ "-18 UNF Grade C tall nuts and $\frac{5}{8}$ " hardened flat washers.

Tighten the U-bolts evenly in 50 foot pounds increments to vehicle manufacturer's torque specifications in the proper pattern to achieve uniform bolt tension as shown in Figure 6-1.

FIGURE 6-1

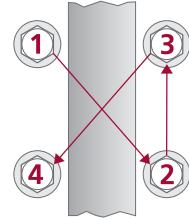

WARNING

IT IS IMPORTANT THAT THE U-BOLT CLAMP GROUP CONNECTION BE PROPERLY ALIGNED AND HAVE THE PROPER TORQUE VALUES MAINTAINED. METAL SURFACES CAN WORK AND WEAR AGAINST OTHER RELATED CLAMP GROUP COMPONENTS IF NOT PROPERLY ALIGNED OR PROPERLY TIGHTENED TO MAINTAIN THE PROPER CLAMP FORCE. FAILURE TO DO SO CAN CAUSE PREMATURE COMPONENT WEAR, POSSIBLE SEPARATION OF THE CLAMP GROUP, CAUSING LOSS OF VEHICLE CONTROL, PROPERTY DAMAGE, OR PERSONAL INJURY.

AXLE BRACKETS

Due to the importance and complexity of the axle housing to axle bracket weld, the axle brackets and axle housing require visual inspection. If the axle brackets show excessive wear, or the welds have cracks, the components will need to be repaired or replaced. If repair is needed, contact the vehicle or axle manufacturer for approved repair procedures.

1. Inspect the axle brackets for signs of excessive wear. Inspect the welds for signs of cracking, see Figure 6-2.
2. Inspect the axle bracket to axle weld for signs of cracking, see Figure 6-2.

FIGURE 6-2

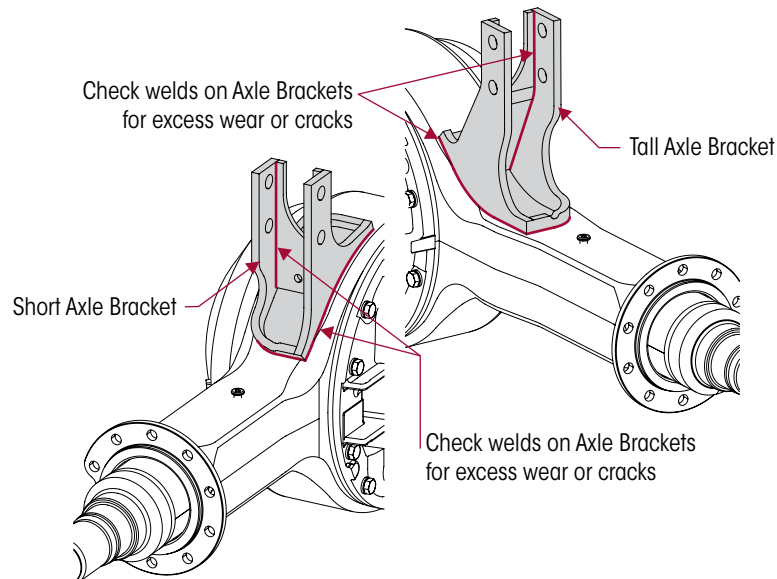

LONGITUDINAL TORQUE RODS

The longitudinal torque rods, coil spring brackets, and the torque box, maintain driveline angles while controlling acceleration, cornering, and braking forces. All torque rods, torque rod bushings and mounting hardware, see Figure 6-3, should be inspected for damage and proper fastener torque every 10,000 miles or annually, whichever comes first to help ensure all components function to their highest efficiency. See Torque Specifications Section of this publication for torque values.

INSPECTION

1. Chock the wheels.
2. Visually inspect the following:
 - a. The torque rods for cracks, bends, breaks, or end hubs which are elongated or oval. Any of these conditions require torque rod replacement.
 - b. The torque rod bushings for torn or shredded rubber. Any of these conditions require torque rod bushing replacement.
 - c. The torque rod assembly for movement while applying pressure with a long pry bar to each torque rod end. If movement is detected, replace torque rod bushings and/or torque rod as required.

NOTE

To replace the torque rod, or torque rod bushings, see the Component Replacement Section of this publication.

3. Remove the wheel chocks.

FIGURE 6-3

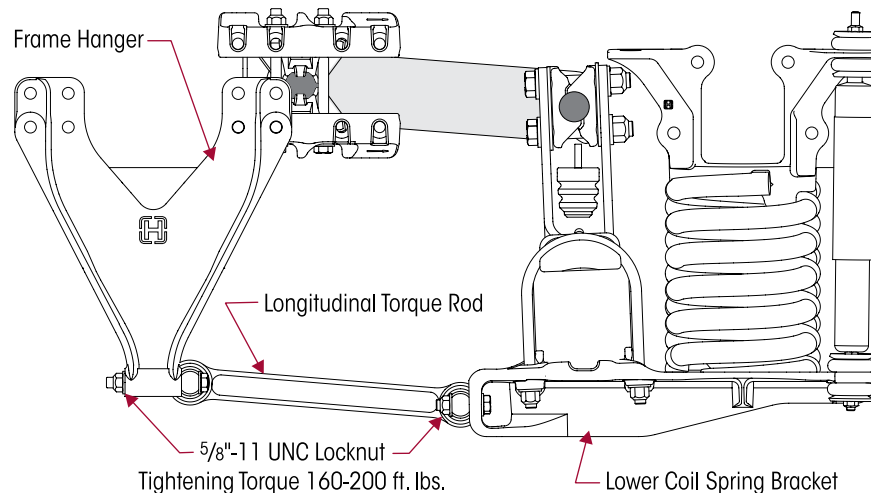



SHOCK ABSORBER INSPECTION

WARNING

THE SHOCK ABSORBERS ARE THE REBOUND TRAVEL STOPS FOR THE SUSPENSION. ANYTIME THE AXLE ON A HTB MECHANICAL SUSPENSION IS SUSPENDED IT IS MANDATORY THAT THE SHOCK ABSORBERS REMAIN CONNECTED. FAILURE TO DO SO WILL RESULT IN OVER-EXTENSION OF THE SUSPENSION, CAUSING DAMAGE TO COMPONENTS. REPLACEMENT OF SHOCK ABSORBERS WITH NON-HENDRICKSON PARTS CAN ALTER THE REBOUND TRAVEL OF THE SUSPENSION.

Hendrickson uses a long service life, premium shock absorber on all HTB Mechanical suspensions. If shock absorber replacement is necessary, Hendrickson recommends that the shock absorbers be replaced with identical Hendrickson Genuine parts for servicing. Failure to do so will affect the suspension performance, durability, and will void the warranty.

Inspection of the shock absorber can be performed by doing a heat test, and a visual inspection. For instructions on shock absorber replacement see the Component Replacement Section of this publication. It is not necessary to replace shock absorbers in pairs if one shock absorber requires replacement.

HEAT TEST

1. Drive the vehicle at moderate speeds on rough road for a minimum of fifteen minutes.

WARNING

DO NOT GRAB THE SHOCK AS IT COULD POSSIBLY CAUSE PERSONAL INJURY.

2. Lightly touch the shock body carefully below the dust cover, see Figure 6-4.
3. Touch the frame to get an ambient reference. A warm shock absorber is acceptable, a cold shock absorber should be replaced.
4. To inspect for an internal failure, remove and shake the suspected shock. (Refer to shock absorber disassembly in Component Replacement Section of this publication). Listen for the sound of metal parts rattling inside. Rattling of metal parts can indicate that the shock has an internal failure.

FIGURE 6-4



VISUAL INSPECTION

Look for these potential problems when doing a visual inspection. Inspect the shock absorbers fully extended. Replace as necessary.

FIGURE 6-5



Damaged upper or lower mount



Damaged upper or lower bushing



Damaged dust cover and / or shock body



Bent or dented shock



Improper installation
Example: washers (if equipped) installed backwards.

LEAKING VS. MISTING SHOCK VISUAL INSPECTION

The inspection must not be conducted after driving in wet weather or a vehicle wash. Shocks need to be free from water. Many shocks are often misdiagnosed as failures. Misting is the process whereby very small amounts of shock fluid evaporate at a high operating temperature through the upper seal of the shock. When the "mist" reaches the cooler outside air, it condenses and forms a film on the outside of the shock body. Misting is perfectly normal and necessary function of the shock. The fluid which evaporates through the seal area helps to lubricate and prolong the life of the seal.

A shock that is truly leaking and needs to be replaced will show signs of fluid leaking in streams from the upper seal. These streams can easily be seen when the shock is fully extended, underneath the main body (dust cover) of the shock. Look for these potential problems when doing a visual inspection. Inspect the shock absorbers fully extended. Replace as necessary.

NOTE

The HTB Mechanical suspension is equipped with a premium seal on the shock, however this seal will allow for misting to appear on the shock body (misting is not a leak and is considered acceptable).

If the shock is damaged install new shock absorber and replace as detailed in the Component Replacement Section of this publication.

FIGURE 6-6



SECTION 7

Alignment & Adjustments

CHECKING AND CORRECTING AXLE ALIGNMENT

ALIGNMENT

Checking and correcting alignment involves performing the following steps in the sequence listed.

STEP	DESCRIPTION	COMMENTS
A	Preparing the vehicle	
B	Measuring the lateral alignment of the torque box	
C	Correcting torque box lateral alignment	(if necessary)
D	Measuring the lateral alignment of the axle	
E	Correcting lateral alignment of the axle	(if necessary)
F	Measuring axle thrust angle	
G	Correcting axle thrust angle	(if necessary)
H	Final Torque	(if adjustments were made)

STEP A. PREPARING THE VEHICLE

1. Use a work bay with a level surface.
2. Relax the suspension by slowly moving the vehicle back and forth several times in a straight line without using the brakes. This will slacken or loosen the suspension as the vehicle is positioned. End with all wheels positioned straight ahead.
3. **DO NOT** set the parking brake. Consult the vehicle manufacturer for parking brake override procedure. Chock the front wheels of the vehicle.
4. Verify all suspension components are in good condition. Repair or replace any worn or damaged suspension components before proceeding with the alignment process.

STEP B. MEASURING TORQUE BOX LATERAL ALIGNMENT (See Figure 7-1)

5. Measure the distance between the left front side of the torque box and the left inside frame rail (A). Record the measurement.
6. Measure the distance between the right front side of the torque box and the right inside frame rail (B). Record the measurement.
7. Measure the distance between the left rear side of the torque box and the left inside frame rail (C). Record the measurement.
8. Measure the distance between the right rear side of the torque box and the right inside frame rail (D). Record the measurement.
9. Calculate the difference between A-B.
10. Calculate the difference between C-D.
11. Calculate the difference between A-C.
12. If all the calculated differences in Steps 9-11 are:
 - a. **equal** to or **less than** ¼", proceed to Step D "Measuring the Lateral Alignment of the Axle."
 - b. **greater than** ¼", this indicates the torque box is either offset or rotated. It will be necessary to correct the lateral alignment of the torque box. Proceed to Step C "Correcting Lateral Alignment of the Torque Box."

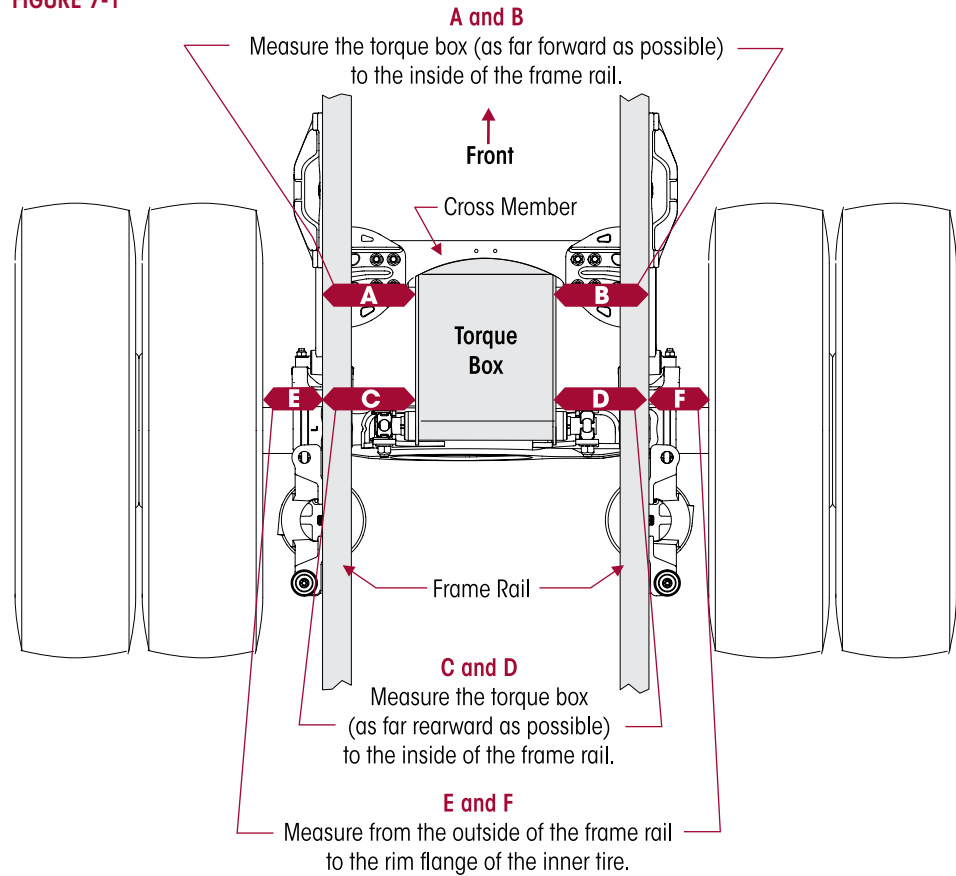
FIGURE 7-1

STEP C. CORRECTING TORQUE BOX LATERAL ALIGNMENT (IF NECESSARY)
NOTE

This step is only necessary if the torque box lateral alignment needs to be corrected as determined in Step B.

13. Support the frame at ride height.
14. See Coil Spring safety related information in the Important Safety Notice Section of this publication prior to compressing or decompressing the suspension system or refer to vehicle manufacturer's instructions.
15. Loosen, **DO NOT** remove torque box clamp bolts at all four corners of the torque box.
16. Using a pry bar, center the torque box in the frame rails. Measurements (**A** and **B**), (**C** and **D**) and (**A** and **C**) should be within $\frac{1}{4}$ " of each other. This will center the torque box and ensure parallelism of the torque box to the frame rails.

WARNING

IT IS IMPORTANT THAT THE TORQUE BOX CLAMP CONNECTIONS BE TIGHTENED IN THE PROPER SEQUENCE AND HAVE THE PROPER TORQUE VALUES MAINTAINED. FAILURE TO DO SO CAN RESULT IN THE DEFORMATION OF PARTS, RESULTING IN THE LOSS OF CLAMP FORCE, BOLT FAILURE, LOSS OF THE AXLE'S ALIGNMENT, LOSS OF VEHICLE CONTROL, PROPERTY DAMAGE, OR PERSONAL INJURY.

CAUTION

THE TORQUE BOX CLAMP BOLTS, AT THE AXLE BRACKETS AND CROSS MEMBER, MUST BE TIGHTENED WHEN THE VEHICLE IS AT RIDE HEIGHT. TIGHTENING THE CLAMP BOLTS WHEN THE VEHICLE IS NOT AT RIDE HEIGHT WILL PRODUCE A TWIST IN THE TORQUE BOX BUSHINGS RESULTING IN PREMATURE COMPONENT WEAR OF THE TORQUE BOX BUSHINGS, IMPROPER RIDE HEIGHT OF THE VEHICLE AND ALTER RIDE QUALITY.

17. First snug, and then tighten the torque box to cross member clamp bolts in the proper sequence (inboard fasteners first then outboard fasteners), to prevent cross member deformation, see Figure 7-2. Tighten the $\frac{5}{8}$ " locknuts to 160-200 foot pounds torque.

FIGURE 7-2

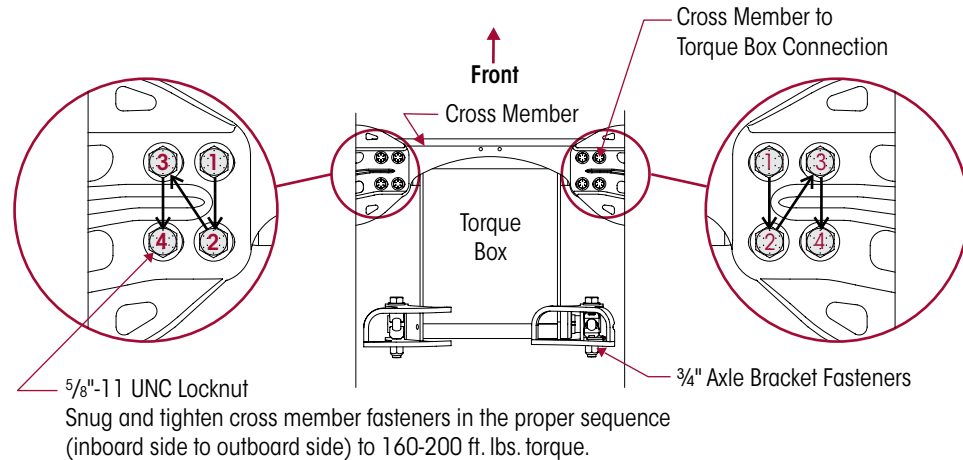

18. Hand-tighten the torque box to axle bracket clamp bolts. **DO NOT** apply final torque to the locknuts at this time as further adjustments may be required.
19. Verify measurements, (A and B), (C and D) and (A and C) should be within 1/4" of each other.

STEP D. MEASURING THE LATERAL ALIGNMENT OF THE AXLE (See Figure 7-1)

20. Measure the distance from the outside of the left frame rail to the rim flange of the left inner tire (E). Record the measurement.
21. Measure the distance from the outside of the right frame rail to the rim flange of the right inner tire (F). Record the measurement.
22. Calculate the difference between the two measurements (E-F).
 - a. (E-F = <1/4") – If the difference is 1/4" or less than proceed to Step F "Measuring Axle Thrust Angle."
 - b. (E-F = >1/4") – If the difference is greater than 1/4", it will be necessary to correct the lateral alignment of the axle. Proceed to Step E "Correcting Lateral Alignment of the Axle".

STEP E. CORRECTING LATERAL ALIGNMENT OF THE AXLE (IF NECESSARY)

NOTE This step is only necessary if the lateral alignment of the axle needs to be corrected as determined in Step D.

NOTE It is important to ensure the torque box is centered and parallel to the frame rails before correcting lateral alignment on an axle. Refer to Step B.

23. Support the frame at ride height.
24. See Coil Spring Warnings and Instructions in the Important Safety Notice Section of this publication prior to compressing or decompressing the suspension system or refer to vehicle manufacturer's instructions.
25. Using the measurements from Step D "Measuring the Lateral Alignment of the Axle" determine which direction the axle needs to be moved to center the axle under the vehicle.
26. Loosen, but **DO NOT** remove the torque box to axle bracket clamp bolts. The bolts may already be loose from Step 18. **DO NOT** loosen the torque box to cross member bolts.
27. Move the axle in the direction required to center the axle under the vehicle. Measurements (E) and (F) should be within 1/4" of each other.
28. Hand-tighten the torque box to axle bracket clamp fasteners. **DO NOT** final torque the bolts at this time.
29. Verify measurement (E) and (F) are within 1/4" of each other.

STEP F. MEASURING AXLE THRUST ANGLE

30. If axle alignment equipment is not available, using “C” clamps, securely clamp a six-foot piece of straight bar stock or angle iron across the lower frame flange as shown in Figure 7-3. Select a location as far forward of the drive axle as possible where components will not interfere.

NOTE

A six-foot minimum length piece of straight bar stock must be used to ensure proper measurement to the axle. Axle alignment equipment must be used if components of body installation prevents the use of a six-foot piece of straight bar stock.

31. Accurately square straight edge to frame using a carpenter’s square.
32. Using a measuring tape, measure from the straight edge to the forward face of the front drive axle arm at the centerline of the axle top pad assembly on both sides of the vehicle as shown in Figure 7-3, (G) and (H).
- If measurements (G) and (H) are within the vehicle manufacturer’s specifications then the thrust alignment of the drive axle is acceptable.
 - If measurements (G) and (H) are not within the vehicle manufacturer’s specifications, it will be necessary to correct the drive axle’s thrust angle. Proceed to Step G “Correcting Axle Thrust Angle.”

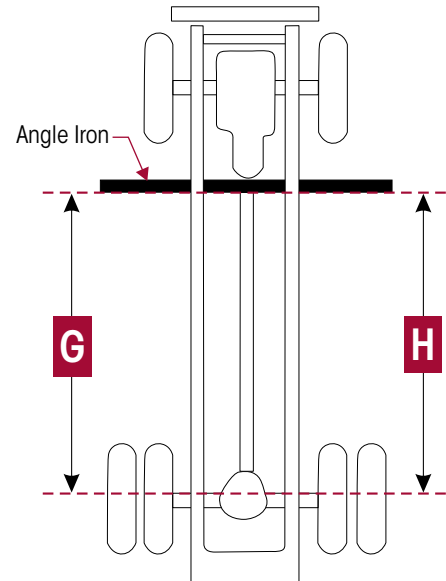
FIGURE 7-3

STEP G. CORRECTING AXLE THRUST ANGLE (IF NECESSARY)
NOTE

The HTB Mechanical is a parallelogram suspension. When correcting an axle’s thrust angle, the shims on both the torque box and longitudinal torque rod must be adjusted in order to maintain parallelism and drive axle pinion angles.

33. Support the frame at ride height.
34. See Coil Spring safety related information in the Important Safety Notice Section of this publication prior to compressing or decompressing the suspension system.
35. Loosen, but **DO NOT** remove the torque box to axle bracket clamp bolts. Note, the bolts may already be loose from Step 18. **DO NOT** loosen the torque box to cross member bolts.

WARNING

THE DRIVE AXLE IS EQUIPPED WITH TWO SETS OF BAR PIN CLAMPS. ONE SET OF BAR PIN CLAMPS WILL BE ADJUSTABLE. THE OTHER SET OF BAR PIN CLAMPS MAY BE EITHER ADJUSTABLE OR NON-ADJUSTABLE. FOUR (4) AXLE BRACKET SHIMS MUST BE USED WITH THE ADJUSTABLE SET OF BAR PIN CLAMPS. THE NON-ADJUSTABLE BAR PIN CLAMPS DO NOT USE ANY AXLE BRACKET SHIMS. IF A PARTICULAR AXLE HAS ADJUSTABLE BAR PIN CLAMPS IN BOTH AXLE BRACKETS, THEN EIGHT (8) AXLE BRACKET SHIMS WILL BE USED (4 PER AXLE BRACKET). THE BAR PIN CLAMP PAIRS CAN BE CHANGED FROM SIDE TO SIDE BUT CANNOT BE MIXED. FAILURE TO PROPERLY INSTALL THE BAR PIN CLAMPS CAN RESULT IN THE DEFORMATION OF PARTS, LOSS OF CLAMP FORCE, BOLT FAILURE, LOSS OF THE AXLE’S ALIGNMENT, LOSS OF VEHICLE CONTROL, PROPERTY DAMAGE, OR PERSONAL INJURY.

36. Locate the axle bracket that contains the adjustable bar pin clamps and axle bracket shims, see Figure 7-4.

FIGURE 7-4

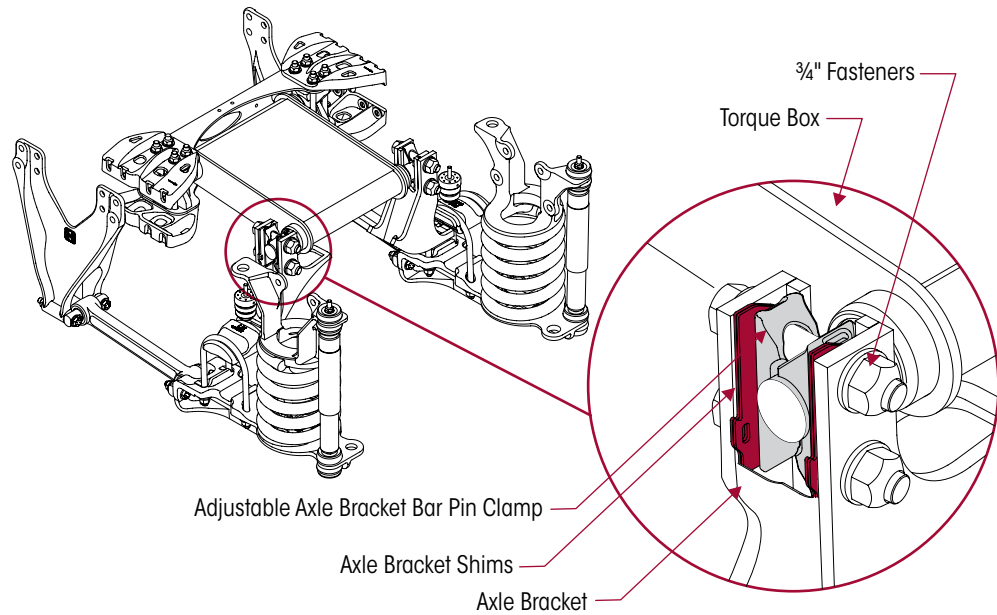

FIGURE 7-5

37. Remove all the axle bracket shims from the axle bracket connection with the adjustable bar pin clamps. **DO NOT** remove adjustable axle bracket bar pin clamps, it is not necessary to remove the adjustable bar pin clamps or the axle bracket connection clamp bolts to perform adjustment.
38. Loosen, but **DO NOT** remove, the fasteners attaching the torque rod to the frame hanger, see Figure 7-5.
39. The position of the floor jacks is important so the lifting force can be transmitted through the center rib of the lower coil spring bracket. Position floor jacks under the center rib and at the rear of each lower coil spring bracket, see Figures 7-6 and 7-7.

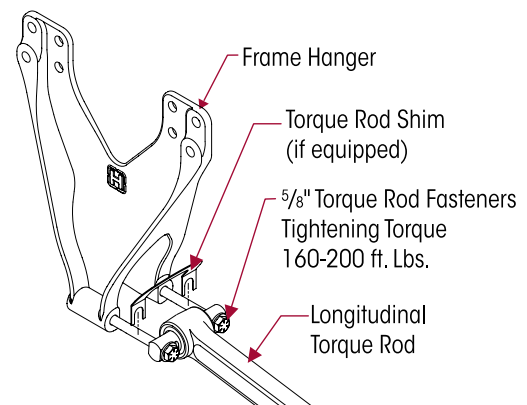

FIGURE 7-6 Compression of the coil spring with floor jack

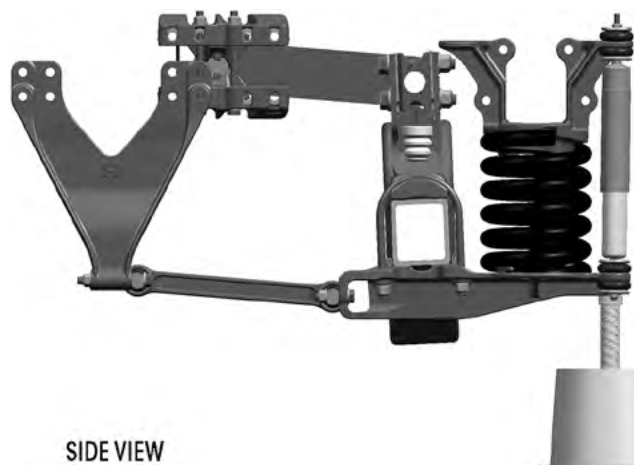
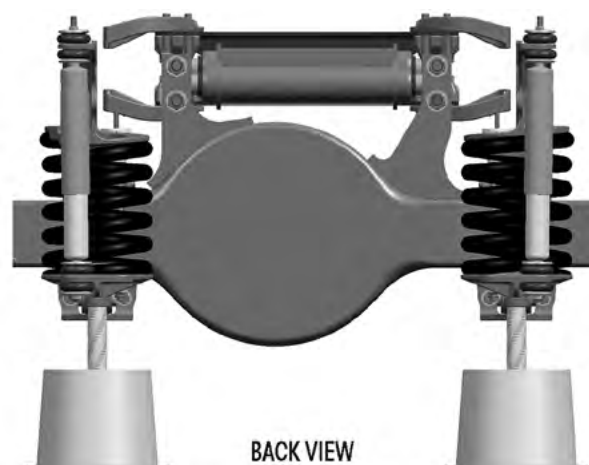

FIGURE 7-7



40. Using the floor jacks as positioned in Step 39, raise both lower coil spring brackets until the torque rods are loose.
41. Add or remove shims between the longitudinal torque rod and the frame hanger connection as required, to adjust the axle thrust angle to within the manufacturer's recommendations, see Figure 7-5.

NOTE

The torque rod shims should only be adjusted on one side of the axle to adjust the thrust angle. Adjusting both longitudinal torque rods will affect the axle's pinion angle.

42. Lower the floor jacks until the vehicle is fully on the ground.
43. Tighten the torque rod attaching fasteners to 160-200 foot pounds torque.

**WARNING**

THE DRIVE AXLE IS EQUIPPED WITH TWO SETS OF BAR PIN CLAMPS. ONE SET OF BAR PIN CLAMPS WILL BE ADJUSTABLE. THE OTHER SET OF BAR PIN CLAMPS MAY BE EITHER ADJUSTABLE OR NON-ADJUSTABLE. FOUR (4) AXLE BRACKET SHIMS MUST BE USED WITH THE ADJUSTABLE SET OF BAR PIN CLAMPS. THE NON-ADJUSTABLE BAR PIN CLAMPS DO NOT USE ANY AXLE BRACKET SHIMS. IF A PARTICULAR AXLE HAS ADJUSTABLE BAR PIN CLAMPS IN BOTH AXLE BRACKETS, THEN EIGHT (8) AXLE BRACKET SHIMS WILL BE USED (4 PER AXLE BRACKET). THE BAR PIN CLAMP PAIRS CAN BE CHANGED FROM SIDE TO SIDE BUT CANNOT BE MIXED. FAILURE TO PROPERLY INSTALL THE BAR PIN CLAMPS CAN RESULT IN THE DEFORMATION OF PARTS, LOSS OF CLAMP FORCE, BOLT FAILURE, LOSS OF THE AXLE'S ALIGNMENT, LOSS OF VEHICLE CONTROL, PROPERTY DAMAGE, OR PERSONAL INJURY.

44. Fill the gap between the axle bracket and the adjustable bar pin clamps with the axle bracket shims removed in Step 37. All four axle bracket shims must be re-installed. **DO NOT** force the axle forward or backwards to install the axle bracket shims. The axle bracket shims may be arranged in any order to achieve an easy fit.

EXAMPLE

The axle bracket shim arrangement may end up being three shims in front and one behind the adjustable bar pin clamps, or no shims in front and four behind the adjustable bar pin clamps, etc.

45. Verify measurements (G) and (H) are within the vehicle manufacturer's specifications.

STEP H. FINAL TORQUE AXLE BRACKET CLAMP BOLTS**WARNING**

IT IS IMPORTANT THAT THE TORQUE BOX CLAMP CONNECTIONS BE TIGHTENED IN THE PROPER SEQUENCE AND HAVE THE PROPER TORQUE VALUES MAINTAINED. FAILURE TO DO SO CAN RESULT IN THE DEFORMATION OF PARTS, RESULTING IN THE LOSS OF CLAMP FORCE, BOLT FAILURE, LOSS OF THE AXLE'S ALIGNMENT, LOSS OF VEHICLE CONTROL, PROPERTY DAMAGE, OR PERSONAL INJURY.

**CAUTION**

THE TORQUE BOX CLAMP BOLTS, AT THE AXLE BRACKETS AND CROSS MEMBER, MUST BE TIGHTENED WHEN THE VEHICLE IS AT RIDE HEIGHT. TIGHTENING THE CLAMP BOLTS WHEN THE VEHICLE IS NOT AT RIDE HEIGHT WILL PRODUCE A TWIST IN THE TORQUE BOX BUSHINGS RESULTING IN PREMATURE COMPONENT WEAR OF THE TORQUE BOX BUSHINGS, IMPROPER RIDE HEIGHT OF THE VEHICLE AND ALTER RIDE QUALITY.

46. Tighten the axle bracket clamp locknuts using the following sequence, see Figure 7-8:
 - a. Pre-torque the **lower** axle bracket clamp fasteners to 50-75 foot pounds.
 - b. Pre-torque the **upper** axle bracket clamp fasteners to 50-75 foot pounds.
 - c. Apply the final torque of 290-315 foot pounds to the **lower** axle clamp fasteners.
 - d. Apply the final torque of 290-315 foot pounds to the **upper** axle clamp fasteners.

FIGURE 7-8

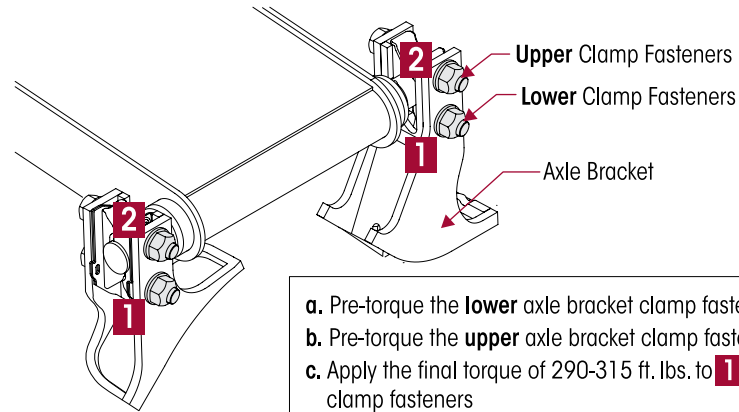

- a. Pre-torque the **lower** axle bracket clamp fasteners to 50-75 ft. lbs.
- b. Pre-torque the **upper** axle bracket clamp fasteners to 50-75 ft. lbs.
- c. Apply the final torque of 290-315 ft. lbs. to **1** the **lower** axle bracket clamp fasteners
- d. Apply the final torque of 290-315 ft. lbs. to **2** the **upper** axle bracket clamp fasteners

47. Remove the frame supports.
48. Engage the parking brake.
49. Remove the wheel chocks.

PINION ANGLE

The vehicle manufacturer establishes the drive axle pinion angles. Contact the vehicle manufacturer for the proper drive axle pinion angle for your vehicle.

1. Use a work bay with a level surface.
2. Relax the suspension by slowly moving the vehicle back and forth several times in a straight line without using the brakes. This will slacken or loosen the suspension as the vehicle is positioned. End with all wheels positioned straight ahead. Try to roll to a stop without the brakes being applied. **DO NOT** set the parking brake. Consult the vehicle manufacturer for parking brake override procedure.
3. Chock the front wheels of the vehicle.
4. Place the digital protractor on the frame rail, at the centerline of the drive axle, and zero the protractor.
5. Place the digital protractor on the axle housing as shown in Figure 7-9.
6. Record the pinion angle for the drive axle. Determine if the pinion angle is within the vehicle manufacturer's specified range.
7. If drive axle pinion angle is out of specification:
 - It will be necessary to adjust the torque rod shims on both sides (left hand and right hand) of the axle in equal amounts. This will maintain axle alignment while correcting the pinion angle.
8. Determine which direction the axle needs to be tilted in order to achieve the correct pinion angle.

FIGURE 7-9





9. See Coil Spring safety related information in the Important Safety Notice Section of this publication prior to compressing or decompressing the suspension system.
10. Loosen, but **DO NOT** remove the fasteners attaching the torque rods to the frame hangers.
11. The position of the floor jacks is important so the lifting force can be transmitted through the center rib of the lower coil spring bracket. Position floor jacks under the center rib and at the rear of each lower coil spring bracket, see Figures 7-10 and 7-11.

FIGURE 7-10

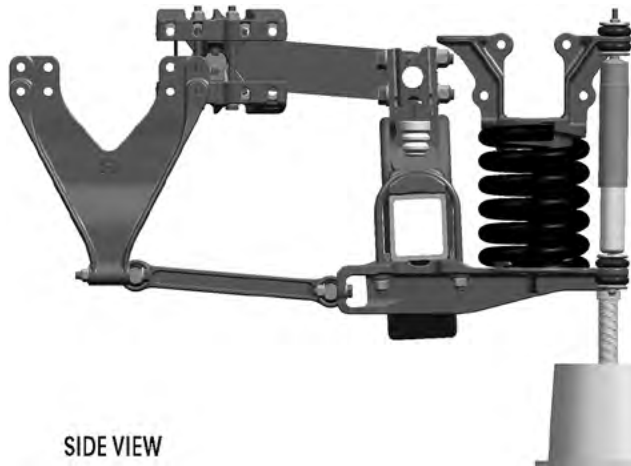
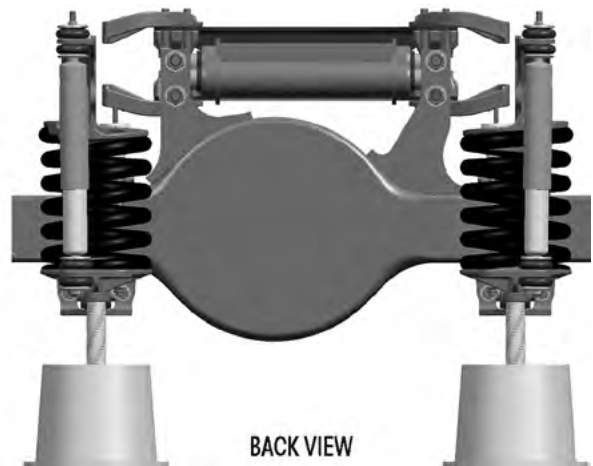

FIGURE 7-11



12. Using the floor jacks as positioned in Step 11, raise both lower coil spring brackets until the torque rods are loose.
13. Add/remove shims at both longitudinal torque rod connections as required to achieve the proper pinion angle. Adjustments must be equal on both sides of the axle in order to maintain axle thrust alignment.
14. Lower the floor jacks until the vehicle is fully on the ground.
15. When the pinion angle is correct, tighten the torque rod fasteners to  160-200 foot pounds of torque and recheck pinion angle, see Figure 7-12.
16. Remove the wheel chocks.

FIGURE 7-12



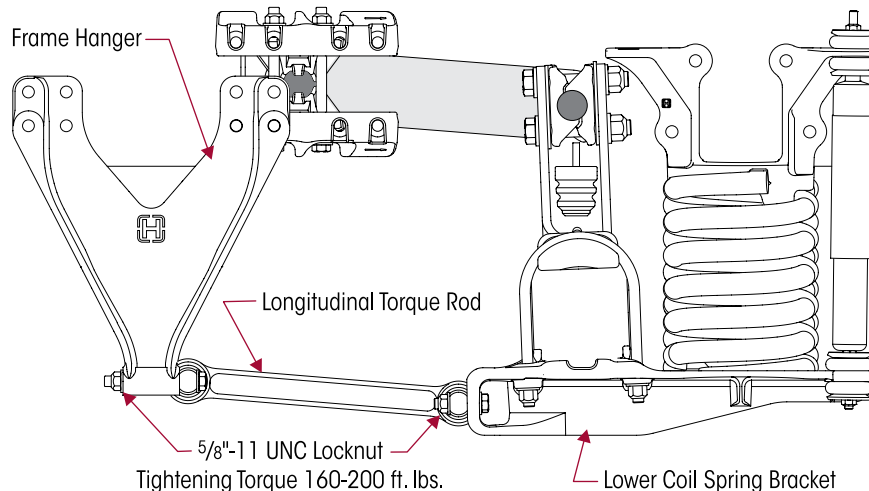

SECTION 8 Component Replacement

SUSPENSION OVERVIEW

The HTB Mechanical suspension uses unique geometry and components to achieve a superior riding and handling vehicle. The suspension uses large coil springs to support the vehicles weight. The forces the coil springs generate are distributed to the frame hangers through the longitudinal torque rods (in compression), and to the cross-member through the torque box (in extension), see Figure 8-1. These components are under constant spring force. When the suspension is disassembled the spring force must be removed. Follow the coil spring component replacement procedure detailed in this section. Review the Important Safety Notice Section of this publication prior to servicing the vehicle.

FIGURE 8-1

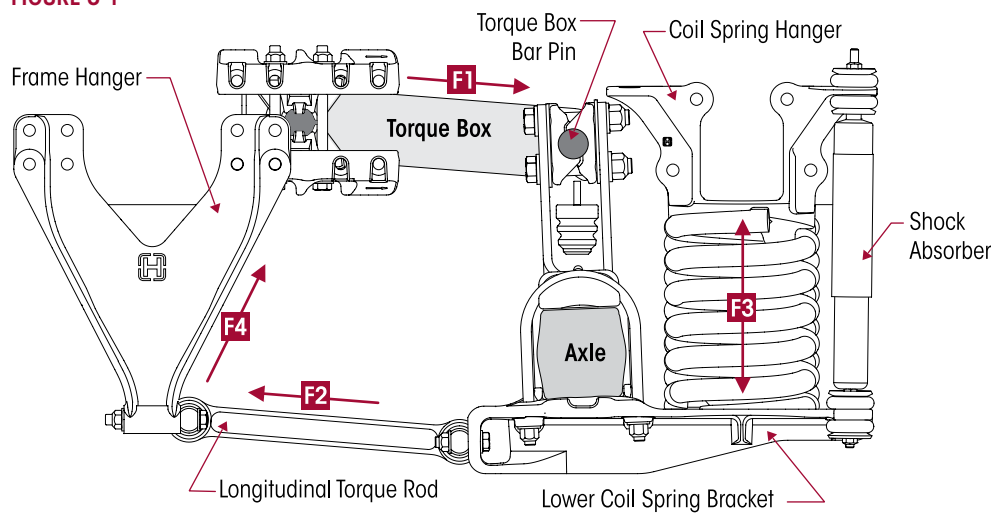

	Direction of Force	Amount of Force
F1	Backward	8200 pounds
F2 Left Hand / F2 Right Hand	Forward	4100 pounds each
F3 Left Hand / F3 Right Hand	Vertical	7850 pounds each
F4 Left Hand / F4 Right Hand	Upward	330 pounds

FASTENERS

Hendrickson recommends when servicing the vehicle, replace all removed fasteners with new equivalent fasteners. Maintain correct torque values at all times. Check torque values as specified. See Hendrickson’s Torque Specifications Section of this publication. If non-Hendrickson fasteners are used, follow torque specifications listed in the vehicle manufacturer’s service manual.

SHOCK ABSORBER



WARNING

THE SHOCK ABSORBERS ARE THE REBOUND TRAVEL STOPS FOR THE SUSPENSION. ANYTIME THE AXLE ON A HTB MECHANICAL SUSPENSION IS SUSPENDED IT IS MANDATORY THAT THE SHOCK ABSORBERS REMAIN CONNECTED. FAILURE TO DO SO WILL RESULT IN OVER-EXTENSION OF THE SUSPENSION, CAUSING DAMAGE TO COMPONENTS. REPLACEMENT OF SHOCK ABSORBERS WITH NON-HENDRICKSON PARTS CAN ALTER THE REBOUND TRAVEL OF THE SUSPENSION.

NOTE

The HTB Mechanical suspension is equipped with gas charged shock absorbers and the shock requires a force of 70 pounds to compress the shock absorbers for service replacement.

DISASSEMBLY

1. Chock the wheels of the vehicle.
2. Remove the locknut, retaining washer, rubber isolator and shock spacer from both the upper and lower mounts of the shock absorbers, see Figure 8-2.
3. Push the shock absorber down and out of the upper shock mount.
4. Remove the shock absorber from the lower mount.

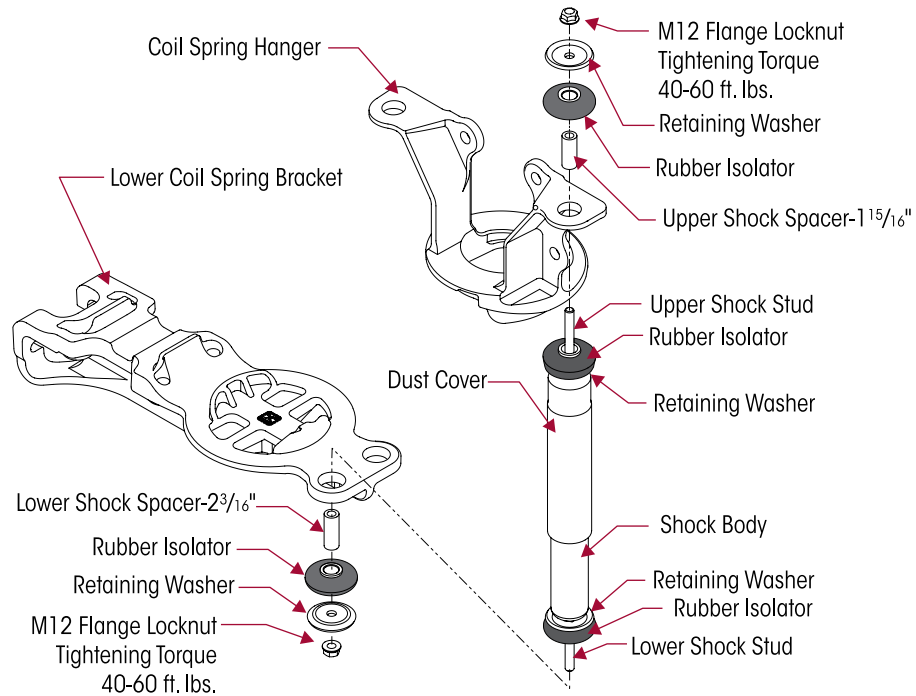
FIGURE 8-2

INSPECTION

1. Inspect the shock absorber, shock absorber mounting brackets and hardware for damage or wear, and replace as necessary, see Preventive Maintenance Section of this publication.

ASSEMBLY

1. Install a retaining washer and rubber isolator onto the upper and lower mounting studs of the shock absorber.
2. Install the lower mounting stud into the outboard shock absorber mounting hole of the lower coil spring bracket.

NOTE

The HTB Mechanical suspension is equipped with gas charged shock absorbers and the shock requires a force of 70 pounds to compress the shock absorbers for service replacement.

3. Push the shock absorber down and install the upper mounting stud into the shock absorber mounting hole of the coil spring hanger.
4. Install the lower shock spacer (2 3/16 inch), rubber isolator, retaining washer and locknut onto the lower mounting stud of the shock absorber. Ensure the longer shock spacer is installed on the lower shock absorber mounting stud.
5. Install the upper shock spacer (1 15/16 inch), rubber isolator, retaining washer and locknut onto the upper shock absorber mounting stud.



6. Tighten both upper and lower locknuts to  40-60 foot pounds of torque.
7. Remove the wheel chocks.

COIL SPRING

DISASSEMBLY

1. Chock the wheels of the vehicle.

WARNING

COIL SPRING STORED ENERGY

IMPROPER RESTRAINT OF COMPRESSED COIL SPRINGS CAN RESULT IN A VIOLENT SHIFT OF COMPONENTS, AND CAUSE SEVERE PERSONAL INJURY, DEATH AND/OR PROPERTY DAMAGE. FULLY DECOMPRESS OR SECURELY RESTRAIN COMPRESSED COIL SPRINGS BEFORE LOOSENING ANY CLAMP GROUP HARDWARE OR DISASSEMBLING ANY PART OF THE SUSPENSION SYSTEM. DO NOT OPERATE THE VEHICLE WITHOUT COIL SPRINGS FULLY INSTALLED AND RESTRICTED BY OTHER SUSPENSION COMPONENTS.

2. Loosen, but **DO NOT** remove the torque box clamp bolts, at both the cross member and the axle brackets.
3. Raise and support the vehicle frame with the wheels off the ground, the suspension in full hang.
4. Remove the wheels from the axle being serviced.
5. Disconnect the parking brake cable. Refer to the vehicle manufacturer's instructions.
6. Remove the brake calipers from the axle. Refer to the vehicle manufacturer's instructions.
7. Remove the drive shaft. Refer to the vehicle manufacturer's instructions.
8. Position a floor jack under the axle, making sure the floor jack securely engages the axle. Raise the axle one to two inches. Support the axle at this height.
9. Remove the locknuts, retaining washers, rubber isolators, and shock spacers from the upper and lower mounts of both shock absorbers.

NOTE

The HTB Mechanical suspension is equipped with gas charged shock absorbers and the shock requires a force of 70 pounds to compress the shock absorbers for service replacement.

10. Push the shock absorber down and out of the coil spring hanger.
11. Remove the shock absorber from the lower coil spring bracket.
12. Repeat Steps 10 and 11 for the remaining shock absorber.
13. Using the floor jack, raise the axle one to two inches and remove the supports from the axle.
14. Lower the axle until both coil springs are loose and decompressed.
15. Remove both coil springs by hand.

ASSEMBLY

1. Lower axle until the coil springs can be installed
2. Install the coil springs making sure the flat end of the spring is on the lower spring seat, see Figure 8-3.
3. Rotate springs so the upper end of each spring is against the upper spring hanger stop, see Figure 8-4.

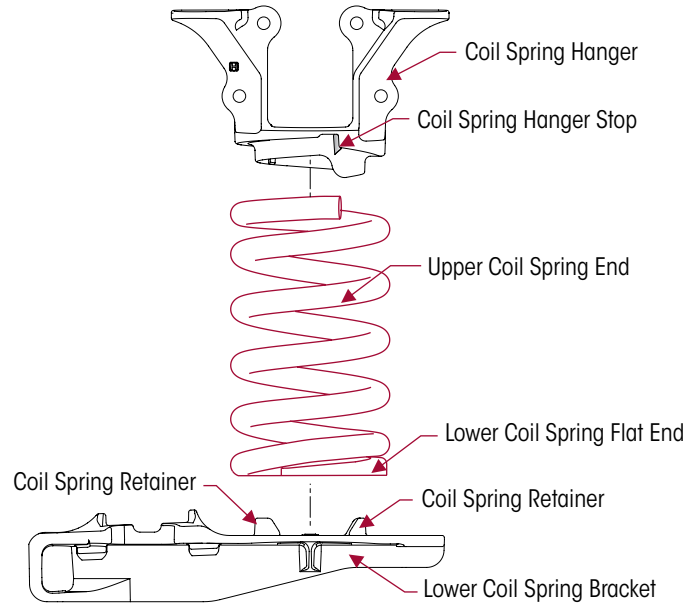
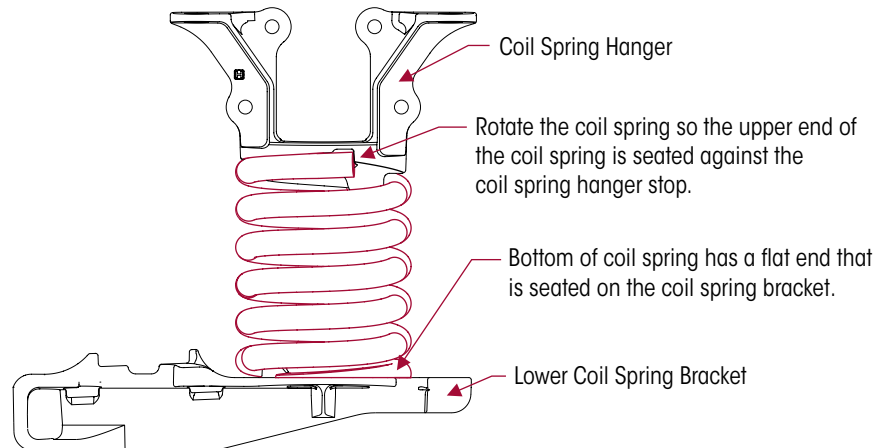
FIGURE 8-3

FIGURE 8-4

4. Raise the axle and install the shock absorbers. Install the shock spacer, rubber isolators, retaining washers, and locknuts onto the upper and lower shock absorber mounts. Ensure the longer spacer is installed on the lower shock absorber mount. Tighten the locknuts to 40-60 foot pounds torque, see Figure 8-2.
5. Install the drive shaft. Refer to the vehicle manufacturer's instructions.
6. Install the brake calipers. Refer to the vehicle manufacturer's instructions.
7. Install the parking brake cable. Refer to the vehicle manufacturer's instructions.
8. Install the wheels.
9. Raise vehicle and remove frame supports.
10. Lower vehicle onto ground so the vehicle is at ride height.

WARNING

IT IS IMPORTANT THAT THE TORQUE BOX CLAMP CONNECTIONS BE TIGHTENED IN THE PROPER SEQUENCE AND HAVE THE PROPER TORQUE VALUES MAINTAINED. FAILURE TO DO SO CAN RESULT IN THE DEFORMATION OF PARTS, RESULTING IN THE LOSS OF CLAMP FORCE, BOLT FAILURE, LOSS OF THE AXLE'S ALIGNMENT, LOSS OF VEHICLE CONTROL, PROPERTY DAMAGE, OR PERSONAL INJURY.

 **CAUTION**

THE TORQUE BOX CLAMP BOLTS, AT THE AXLE BRACKETS AND CROSS MEMBER, MUST BE TIGHTENED WHEN THE VEHICLE IS AT RIDE HEIGHT. TIGHTENING THE CLAMP BOLTS WHEN THE VEHICLE IS NOT AT RIDE HEIGHT WILL PRODUCE A TWIST IN THE TORQUE BOX BUSHINGS RESULTING IN PREMATURE COMPONENT WEAR OF THE TORQUE BOX BUSHINGS, IMPROPER RIDE HEIGHT OF THE VEHICLE AND ALTER RIDE QUALITY.

1. Align the torque box and axle; including proper tightening of the torque box clamp bolts. Refer to the Alignment & Adjustments Section of this publication.

COIL SPRING HANGER

DISASSEMBLY

1. Remove both coil springs. See Coil Spring Disassembly procedure in this section.
2. Remove fasteners securing coil spring hanger to the frame rail.
3. Remove the coil spring hanger.

INSPECTION

1. Inspect the coil spring hanger for cracks, wear or damage. Replace as necessary.
2. Inspect the coil spring for damage or wear. Replace as necessary.
3. Inspect the lower coil spring bracket for cracks, wear, or damage. Replace as necessary.

ASSEMBLY

1. Install the upper coil spring hanger to the frame rail.
2. Tighten/crimp coil spring hanger to frame rail fasteners per the vehicle manufacturer's specifications.
3. Install the coil springs. See the Coil Spring Assembly procedure in this section, including alignment of the torque box and axle.

FRAME HANGER

DISASSEMBLY

1. Remove both coil springs. See Coil Spring Disassembly procedure in this section.
2. Raise and support the drive axle at ride height.
3. Support the pinion of the drive axle.

NOTE

Prior to disassembly of the longitudinal torque rod fasteners, note the orientation and quantity of torque rod shims, see Figure 8-5. It is required that the longitudinal torque rod shims be installed in the same orientation and location as removed to preserve the existing alignment and pinion angles.

FIGURE 8-5

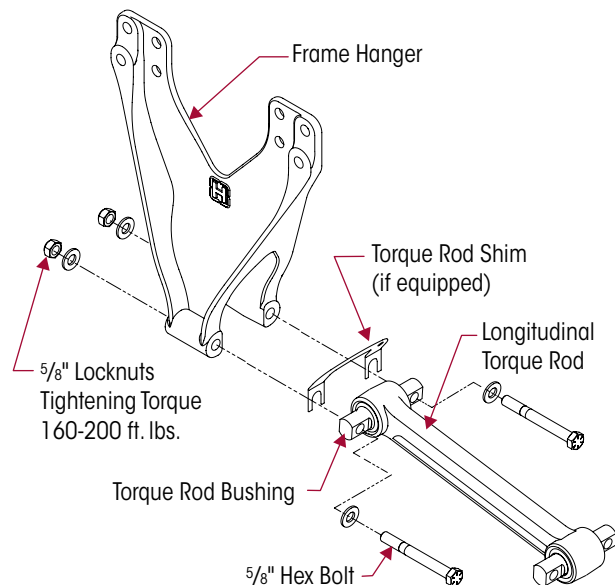

4. Remove the fasteners and any torque rod shims (if equipped) attaching the torque rod to the frame hanger.



5. Remove the fasteners attaching the frame hanger to the frame rail. Refer to the vehicle manufacturer's instructions.
6. Remove the frame hanger(s).

INSPECTION

1. Inspect the cross member C-channel, gussets, and frame hanger for signs of excessive wear, cracking or damage. Replace as necessary. See the Preventive Maintenance Section of this publication.
2. Inspect the frame rail for signs of wear, cracking or damage. Repair as necessary. Refer to vehicle manufacturer's instructions.

ASSEMBLY

1. Install the frame hanger(s) onto the frame rail(s).

NOTE

There are several different length fasteners used to connect the frame hanger to the frame rail. Verify the proper fastener length is used in the proper location. Refer to the vehicle manufacturer's specifications.

2. Tighten / crimp frame hanger to the frame rail fasteners per the vehicle manufacturer's specifications.

NOTE

It is required that the longitudinal torque rod shims be installed in the same orientation and location as removed to preserve the existing alignment and pinion angle.

3. Install the longitudinal torque rod fasteners and any shims (if equipped) that were removed during disassembly. Tighten the torque rod attaching fasteners to  160-200 foot pounds torque, see Figure 8-5.
4. Install the coil springs. See the Coil Spring Assembly procedure in this section, including alignment of the torque box and axle.

LONGITUDINAL TORQUE ROD



IMPROPER RESTRAINT OF COMPRESSED COIL SPRINGS CAN RESULT IN A VIOLENT SHIFT OF COMPONENTS, AND CAUSE SEVERE PERSONAL INJURY, DEATH AND/OR PROPERTY DAMAGE. FULLY DECOMPRESS OR SECURELY RESTRAIN COMPRESSED COIL SPRINGS BEFORE LOOSENING ANY CLAMP GROUP HARDWARE OR DISASSEMBLING ANY PART OF THE SUSPENSION SYSTEM. DO NOT OPERATE THE VEHICLE WITHOUT COIL SPRINGS FULLY INSTALLED AND RESTRICTED BY OTHER SUSPENSION COMPONENTS.

PRIOR TO SERVICING A SINGLE LONGITUDINAL TORQUE ROD, MAKE SURE:

- BOTH COMPRESSED COIL SPRINGS ARE PROPERLY SECURED BY ENGAGING A FLOOR JACK LOCATED UNDER THE RESPECTIVE LOWER COIL SPRING BRACKETS,
- THE LONGITUDINAL TORQUE ROD ON THE OPPOSITE SIDE OF THE VEHICLE IS PROPERLY CONNECTED TO THE FRAME HANGER AND LOWER COIL SPRING BRACKET,
- THE TORQUE BOX CONNECTIONS ARE PROPERLY ASSEMBLED AND TIGHTENED TO THE SPECIFIED TORQUE VALUES.

NOTE

If service requires removal of both longitudinal torque rods, prior to disassembly both coil springs must be removed. Refer to the Coil Spring disassembly procedure in this section.



DISASSEMBLY

1. Chock the wheels of the vehicle.
2. The position of the floor jacks is important so the lifting force can be transmitted through the center rib of the lower coil spring bracket. Position floor jacks under the center rib and at the rear of each lower coil spring bracket, see Figures 8-6 and 8-7.

FIGURE 8-6

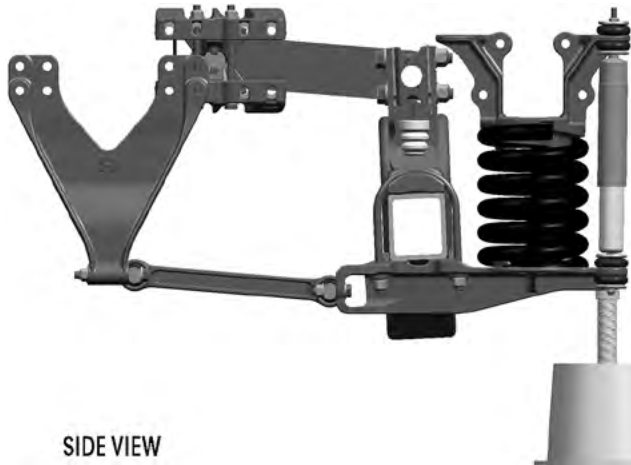

SIDE VIEW

FIGURE 8-7

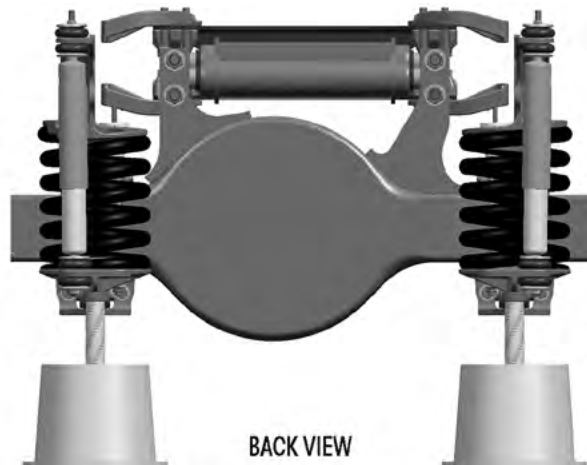

BACK VIEW

3. See Coil Spring safety related information in the Important Safety Notice Section of this publication prior to compressing or decompressing the suspension system.
4. Loosen, but **DO NOT** remove the fasteners attaching the torque rod being serviced to the frame hanger and to the lower coil spring bracket, see Figure 8-8. **DO NOT** loosen the torque rod on the opposite side of the suspension.

FIGURE 8-8

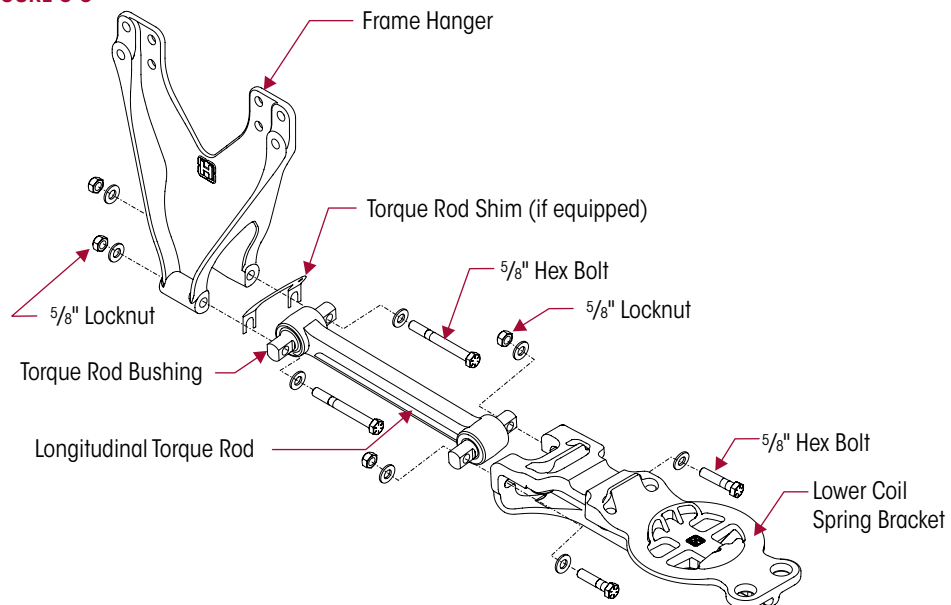

5. Using the floor jacks as positioned in Step 2, raise both lower coil spring brackets until the torque rods are loose.

NOTE

Prior to disassembly of the longitudinal torque rod fasteners, note the orientation and quantity of torque rod shims, see Figure 8-8. It is required that the longitudinal torque rod shims be installed in the same orientation and location as removed to preserve the existing alignment and pinion angles.



CAUTION

FAILURE TO INSTALL THE TORQUE ROD SHIMS IN THE SAME ORIENTATION AND LOCATION MAY REQUIRE A VEHICLE ALIGNMENT. IMPROPER VEHICLE ALIGNMENT CAN INCREASE TIRE WEAR.

6. Remove the fasteners and any shims (if equipped) attaching the torque rod being serviced to the frame hanger and to the lower coil spring bracket.
7. Remove the longitudinal torque rod.
8. Lower the floor jacks.

INSPECTION

1. Inspect all mating components for damage or wear. Replace as necessary.
2. Visually inspect the following:
 - a. The torque rods for cracks, bends, breaks, or end hubs, which are elongated or oval. Any of these conditions require torque rod replacement.
 - b. The torque rod bushings for torn or shredded rubber. Any of these conditions require torque rod bushing replacement.

ASSEMBLY

1. Position the floor jacks under the rear of both lower coil spring brackets, see Figure 8-6. It is important to position the floor jacks at the rear of the lower coil spring brackets so the lifting force can be transmitted through the center rib of the lower coil spring brackets, see Figure 8-7.
2. Using the floor jacks, raise the lower coil spring brackets until the torque rod and shims can be positioned between the frame hanger and the lower coil spring bracket.
3. Position the torque rod between the frame hanger and lower coil spring bracket.

NOTE

It is required that the longitudinal torque rod shims be installed in the same orientation and location as removed to preserve the existing alignment and pinion angles.

4. Loosely install the fasteners and any shims that were removed during the disassembly procedure which attach the torque rod to the frame hanger. **DO NOT** tighten at this time.
5. Lower the floor jacks until the vehicle is fully on the ground.
6. Remove the floor jacks.
7. Tighten the torque rod attaching fasteners to 160-200 foot pounds of torque.
8. Remove the wheel chocks.

TORQUE ROD BUSHING

DISASSEMBLY

You will need:

- A vertical press with a capacity of at least 10 tons.
- Torque Rod Bushing Receiving Tool, see Special Tools Section of this publication
- Torque Rod Bushing Assembly Tool (Funnel) – Part No. 66086-000, see Special Tools Section of this publication



WARNING

DO NOT USE HEAT OR USE A CUTTING TORCH TO REMOVE THE BUSHINGS FROM THE LONGITUDINAL TORQUE ROD. THE USE OF HEAT WILL ADVERSELY AFFECT THE STRENGTH OF THE LONGITUDINAL TORQUE ROD. HEAT CAN CHANGE THE MATERIAL PROPERTIES. A COMPONENT DAMAGED IN THIS MANNER CAN RESULT IN THE LOSS OF VEHICLE CONTROL AND POSSIBLE PERSONAL INJURY OR PROPERTY DAMAGE.

1. Remove the longitudinal torque rod as detailed in this section.

2. Install the longitudinal torque rod in the press. Support the longitudinal torque rod end hub on the receiving tool with the end hub of the longitudinal torque rod centered on the tool. Be sure the longitudinal torque rod is squarely supported on the press bed.
3. Push directly on the bar pin until the bushing clears the longitudinal torque rod end hub.

INSPECTION AND CLEANING

1. Inspect the longitudinal torque rod for straightness, wear, or cracks. Replace as necessary.

NOTE

Care must be used when servicing the aluminum longitudinal torque rod and aluminum bar pin components to avoid damaging them.

2. Clean and inspect the inner diameter of the longitudinal torque rod end tubes. Break any sharp edges and remove any nicks with an emery cloth.

ASSEMBLY

NOTE

DO NOT use petroleum or soap base lubricant. Such lubricants can cause adverse reactions with the bushing, such as deterioration of the rubber, causing premature failure.

1. Lubricate the inner diameter of the torque rod end hub, the assembly funnel, and the new rubber bushing with P-80 Lubricant (refer to Parts List Section of this publication) or light Naphthenic Base Oil, such as 60 SUS at 100°F, see Figure 8-9.
2. Support the torque rod end hub on the receiving tool with the end hub of the torque rod centered on the receiving tool, see Figure 8-10.

FIGURE 8-9



NOTE

When replacing a straddle mount bar pin type bushing assembly, verify the correct clocking position of the straddle mount bar pin flats prior to installing the bushing assembly in the torque rod end hub.

3. Place the torque rod bushing centered in the torque rod end hub, see Figure 8-11. The bar pin must have the mounting flats positioned as indicated in Figure 8-12.

FIGURE 8-10

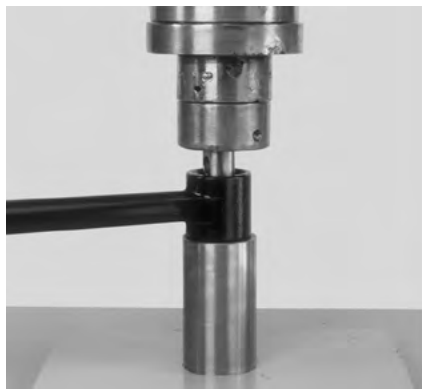
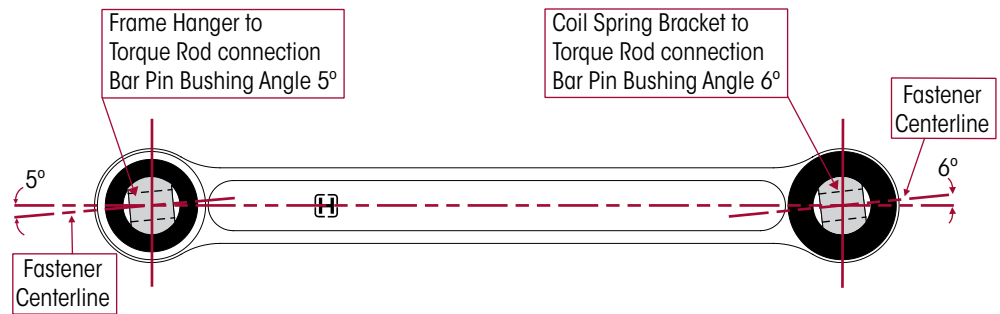

FIGURE 8-11



FIGURE 8-12

4. Press the torque rod bushing into the torque rod end hub. When pressing in the new bushings overshoot the desired final position by approximately $\frac{3}{16}$ " see Figure 8-13.
5. Press the bar pin again from the opposite side to center the bar pin within the torque rod end hub, see Figure 8-14. The rubber bushing and the bar pin must be centered within the torque rod end hubs.

FIGURE 8-13

FIGURE 8-14

6. Wipe off any excess lubricant. Allow the lubricant a minimum of four hours to dissipate before operating the vehicle.

CAUTION

IF THE TORQUE ROD ASSEMBLY IS NOT ALLOWED THE ALLOTTED TIME FOR THE LUBRICANT TO DISSIPATE, THE BUSHING WILL SLIDE FROM THE LONGITUDINAL TORQUE ROD END HUB. IF THIS OCCURS, THE BUSHING MAY BE DAMAGED AND THE BUSHING WILL NEED TO BE REMOVED AND A NEW BUSHING RE-INSTALLED.

7. Install longitudinal torque rod assembly as detailed in this section.

TORQUE BOX

It is important to inspect the torque box during preventive maintenance service. Visually inspect the torque box for cracks, damage, torn or shredded rubber, or any signs of looseness at the bar pin clamps. Replace all worn or damaged parts. The torque box is a non-serviceable item and must be replaced as an assembly, if damaged, or the bushings are worn out. Check all fasteners for proper torque, see Torque Specifications Section of this publication.

DISASSEMBLY

1. Remove both coil springs, see Coil Spring Disassembly procedure in this section.
2. Raise the axle to ride height and support with jack stands.
3. Support the drive axle pinion with a jack stand.

 **WARNING**

THE DRIVE AXLE IS EQUIPPED WITH TWO SETS OF BAR PIN CLAMPS. ONE SET OF BAR PIN CLAMPS WILL BE ADJUSTABLE. THE OTHER SET OF BAR PIN CLAMPS MAY BE EITHER ADJUSTABLE OR NON-ADJUSTABLE. FOUR (4) AXLE BRACKET SHIMS MUST BE USED WITH THE ADJUSTABLE SET OF BAR PIN CLAMPS. THE NON-ADJUSTABLE BAR PIN CLAMPS DO NOT USE ANY AXLE BRACKET SHIMS. IF A PARTICULAR AXLE HAS ADJUSTABLE BAR PIN CLAMPS IN BOTH AXLE BRACKETS, THEN EIGHT (8) AXLE BRACKET SHIMS WILL BE USED (4 PER AXLE BRACKET). THE BAR PIN CLAMP PAIRS CAN BE CHANGED FROM SIDE TO SIDE BUT CANNOT BE MIXED. FAILURE TO PROPERLY INSTALL THE BAR PIN CLAMPS CAN RESULT IN THE DEFORMATION OF PARTS, LOSS OF CLAMP FORCE, BOLT FAILURE, LOSS OF THE AXLE'S ALIGNMENT, LOSS OF VEHICLE CONTROL, PROPERTY DAMAGE, OR PERSONAL INJURY.

NOTE

Prior to disassembly of the axle bracket clamp bolts, note the orientation and quantity of axle bracket shims, see Figure 8-16. It is required that the axle bracket shims be installed in the same orientation and location as removed to preserve the existing alignment and pinion angles.

4. Remove the axle bracket clamp bolts from the axle bracket (2 per side).

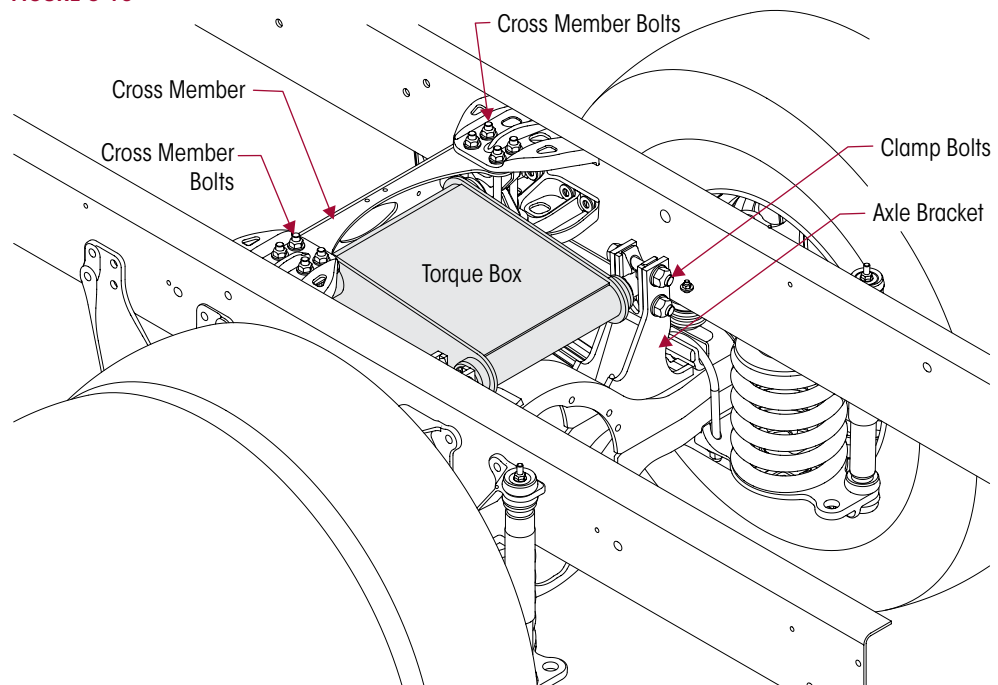
FIGURE 8-15

5. Remove the cross member clamp bolts from the cross member (4 per side), see Figure 8-15.
6. Raise the torque box up and out of the axle bracket. Retain the axle bracket bar pin clamps and shims.

 **CAUTION**

THE TORQUE BOX IS HEAVY (APPROXIMATELY 100 POUNDS). THE USE OF A LIFTING DEVICE IS REQUIRED FOR REMOVAL AND INSTALLATION OF THE TORQUE BOX. DO NOT ATTEMPT REMOVAL OR INSTALLATION WITHOUT THE PROPER EQUIPMENT.

7. Slide the torque box out of the cross member and remove.

INSPECTION

1. Inspect all mating components including torque box, torque box bushings, and bar pin clamps for cracks, damage or wear. Replace as necessary.
2. Inspect cross member C-channel, cross member gussets, and bar pin clamps for cracks, signs of damage, or wear. Replace as necessary.
3. Inspect the axle housing for cracks, wear, or damage. If repair is needed, contact the vehicle or axle manufacturer for approved repair procedures.

ASSEMBLY

CAUTION

THE TORQUE BOX IS HEAVY (APPROXIMATELY 100 POUNDS). THE USE OF A LIFTING DEVICE IS REQUIRED FOR REMOVAL AND INSTALLATION OF THE TORQUE BOX. DO NOT ATTEMPT REMOVAL OR INSTALLATION WITHOUT THE PROPER EQUIPMENT.

1. Maneuver the torque box into position by first sliding the torque box bar pin into the cross-member C-channel, then into the axle brackets.
2. Slide the cross member bar pin clamps onto the torque box bar pin from the side. Loosely install the eight cross member bolts through the cross member and cross member bar pin clamps. **DO NOT** tighten at this time, see Figure 8-16.

FIGURE 8-16

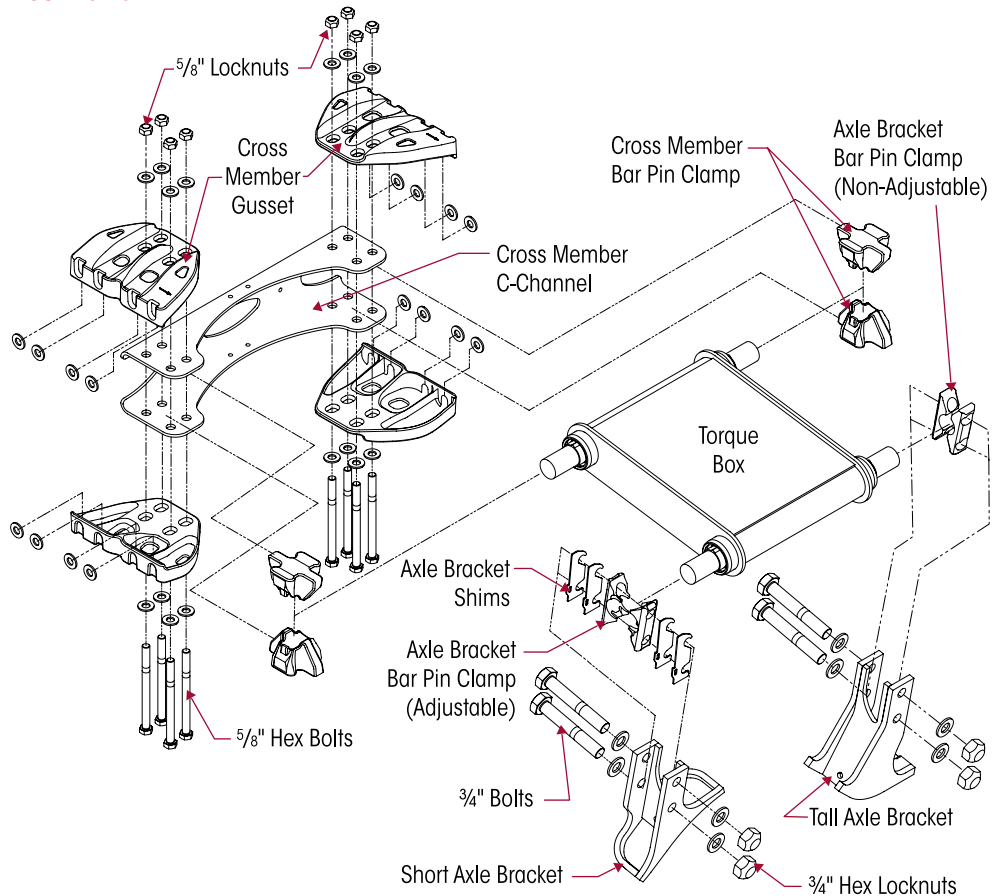

WARNING

THE DRIVE AXLE IS EQUIPPED WITH TWO SETS OF BAR PIN CLAMPS. ONE SET OF BAR PIN CLAMPS WILL BE ADJUSTABLE. THE OTHER SET OF BAR PIN CLAMPS MAY BE EITHER ADJUSTABLE OR NON-ADJUSTABLE. FOUR (4) AXLE BRACKET SHIMS MUST BE USED WITH THE ADJUSTABLE SET OF BAR PIN CLAMPS. THE NON-ADJUSTABLE BAR PIN CLAMPS DO NOT USE ANY AXLE BRACKET SHIMS. IF A PARTICULAR AXLE HAS ADJUSTABLE BAR PIN CLAMPS IN BOTH AXLE BRACKETS, THEN EIGHT (8) AXLE BRACKET SHIMS WILL BE USED (4 PER AXLE BRACKET). THE BAR PIN CLAMP PAIRS CAN BE CHANGED FROM SIDE TO SIDE BUT CANNOT BE MIXED. FAILURE TO PROPERLY INSTALL THE BAR PIN CLAMPS CAN RESULT IN THE DEFORMATION OF PARTS, LOSS OF CLAMP FORCE, BOLT FAILURE, LOSS OF THE AXLE'S ALIGNMENT, LOSS OF VEHICLE CONTROL, PROPERTY DAMAGE, OR PERSONAL INJURY.

NOTE

It is required that the axle bracket shims be installed in the same orientation and location as removed to preserve the existing alignment and pinion angles.

3. Install the axle bracket bar pin clamps and all axle bracket shims that were removed during disassembly. Ensure all axle bracket shims are installed in the same position as noted upon disassembly. Loosely install axle bracket clamp bolts. **DO NOT** tighten at this time, see Figure 8-17.
4. Install the coil springs. See the Coil Spring Assembly procedure in this section, including alignment of the torque box and axle.

FIGURE 8-17

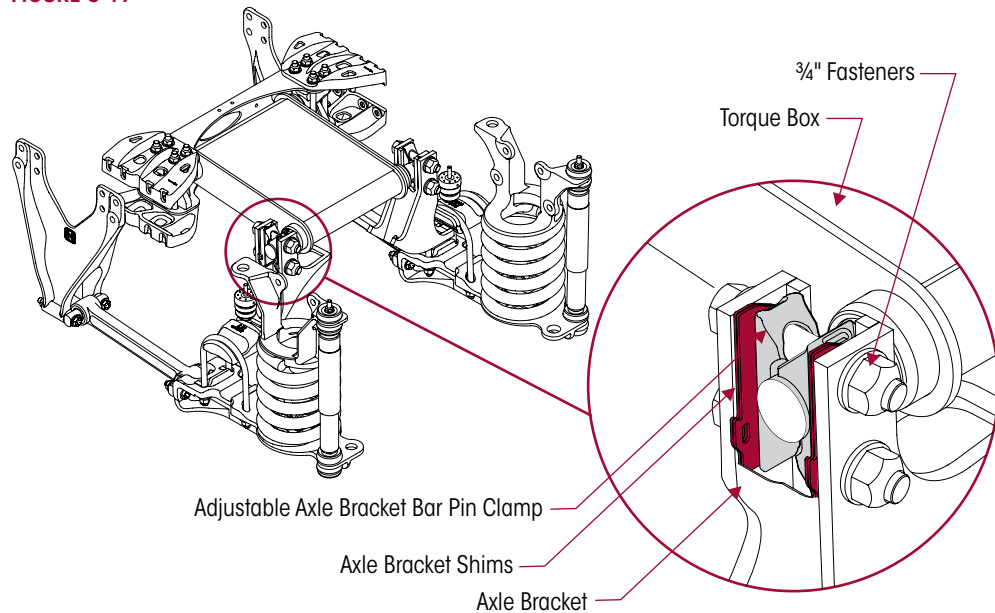

CLAMP GROUP (Top Pad, Lower Coil Spring Bracket, U-bolts)

WARNING

IT IS IMPORTANT THAT THE U-BOLT CLAMP GROUP CONNECTION IS PROPERLY ALIGNED AND HAS THE PROPER TORQUE VALUES MAINTAINED. METAL SURFACES CAN WORK AND WEAR AGAINST OTHER RELATED CLAMP GROUP COMPONENTS IF NOT PROPERLY ALIGNED OR PROPERLY TIGHTENED TO MAINTAIN THE PROPER CLAMP FORCE. FAILURE TO DO SO CAN CAUSE PREMATURE COMPONENT WEAR, POSSIBLE SEPARATION OF THE CLAMP GROUP, CAUSING LOSS OF VEHICLE CONTROL, PROPERTY DAMAGE, OR PERSONAL INJURY.

DISASSEMBLY

DANGER

IMPROPER RESTRAINT OF COMPRESSED COIL SPRINGS CAN RESULT IN A VIOLENT SHIFT OF COMPONENTS, AND CAUSE SEVERE PERSONAL INJURY, DEATH AND/OR PROPERTY DAMAGE. FULLY DECOMPRESS OR SECURELY RESTRAIN COMPRESSED COIL SPRINGS BEFORE LOOSENING ANY CLAMP GROUP HARDWARE OR DISASSEMBLING ANY PART OF THE SUSPENSION SYSTEM. DO NOT OPERATE THE VEHICLE WITHOUT COIL SPRINGS FULLY INSTALLED AND RESTRICTED BY OTHER SUSPENSION COMPONENTS.

1. Remove both coil springs. See Coil Spring Disassembly procedure in this section.
2. Raise the axle to ride height and support with jack stands.
3. Support the drive axle pinion with a jack stand.

NOTE

Prior to disassembly of the longitudinal torque rod fasteners, note the orientation and quantity of torque rod shims, see Figure 8-18. It is required that the longitudinal torque rod shims be installed in the same orientation and location as removed to preserve the existing alignment and pinion angles.

4. Remove the fasteners and shims (if equipped) securing the torque rod to the lower coil spring bracket.
5. Remove the U-bolts from the clamp group.

6. Remove the lower coil spring bracket.
7. Remove the top pad.

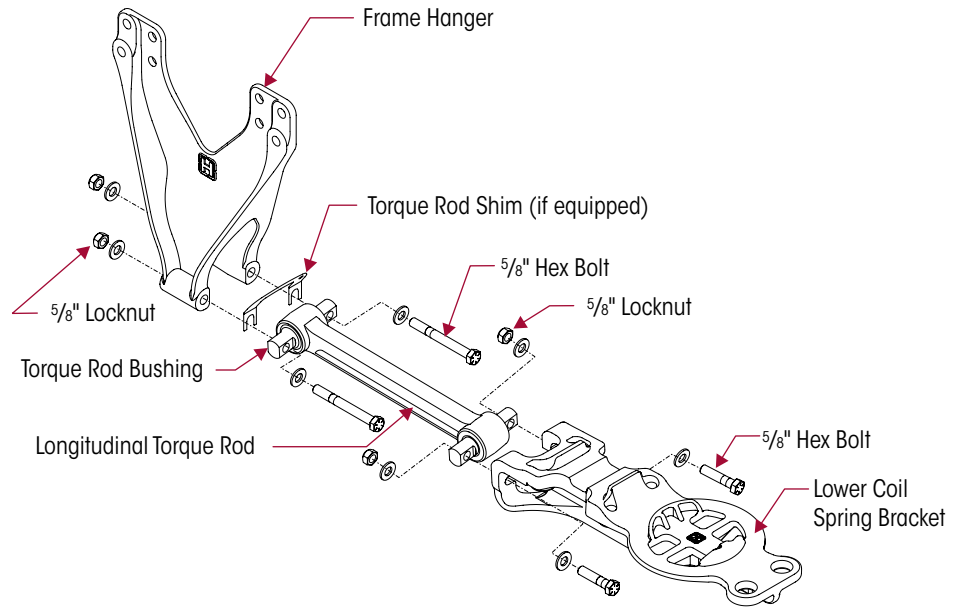
FIGURE 8-18

INSPECTION

1. Inspect the lower coil spring bracket for cracks, wear, or damage. Replace as needed.
2. Inspect the top pad for cracks, wear, or damage. Replace as needed.
3. Inspect the axle housing for cracks, wear, or damage. If repair is needed, contact the vehicle or axle manufacturer for approved repair procedures.

FIGURE 8-19
ASSEMBLY

1. Install the top pad on the axle housing engaging the alignment dowel pin. Verify the top pad is on the correct side of the axle housing and the arrow is pointing towards the front of the vehicle, see Figure 8-19.
2. The two markings on the top pad indicate the correct orientation of the top pad, see Figure 8-19.

A. RH (Right Hand), LH (Left Hand) designates the correct side of the axle to install the top pad.

B. The **FRONT** arrow must point towards the front of the vehicle.

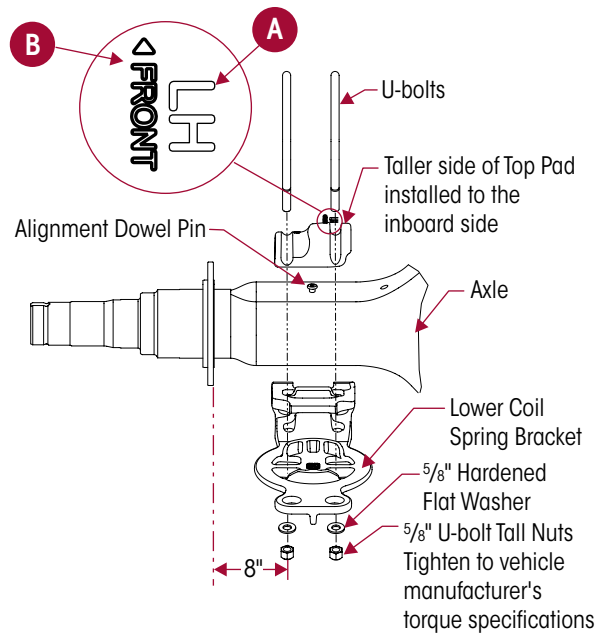
NOTE

Current Hendrickson Truck Suspension Systems U-bolt clamp group hardware for the HTB Mechanical suspension consist of 5/8"-18 UNF Grade C tall nuts, 5/8" hardened flat washers, and phosphate and oil coated 5/8"-18 UNF Grade 8 U-bolts.

3. Install new U-bolts over the top pad. Ensure the U-bolts are seated in the channels of the top pad, see Figure 8-20.

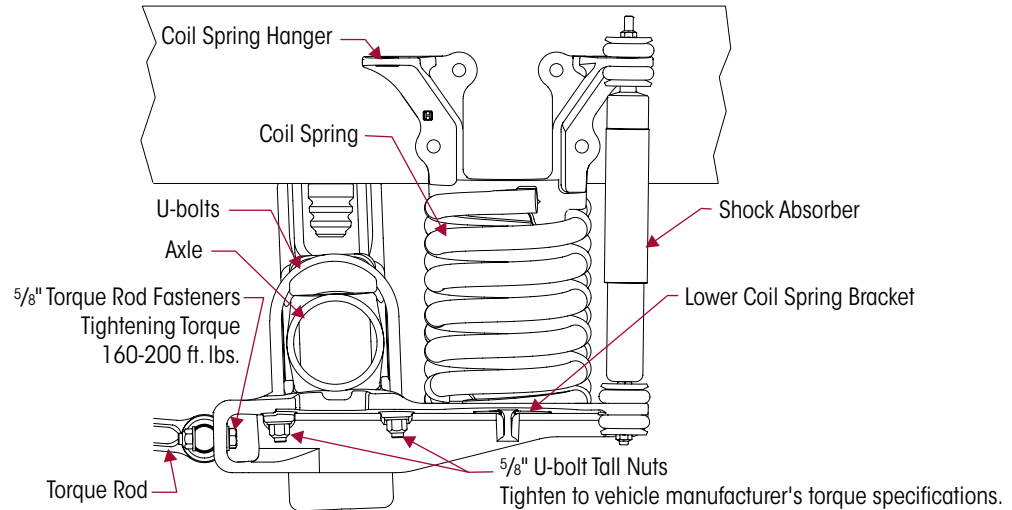
FIGURE 8-20

4. Install the lower coil spring bracket onto the U-bolts.
5. Loosely install the U-bolt washers and tall nuts onto the U-bolts.
6. Tighten the U-bolt until the lower coil spring bracket is in contact with the bottom of the axle housing but is not tight.
7. Align the lower coil spring bracket to the axle housing. The lower coil spring bracket should be centered under the top pad and flush with the front face of the axle housing.

SERVICE HINT

Measure center of outer U-bolt legs under lower coil spring bracket to inside face of brake flange. Clamp group is properly centered if measurement is 8.0", see Figure 8-19.

8. Tighten the U-bolt tall nuts evenly in 50 foot pounds increments to vehicle manufacturer's torque specifications in the proper pattern to achieve uniform bolt tension, see Figure 8-21.

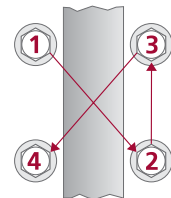
FIGURE 8-21**NOTE**

It is required that the longitudinal torque rod shims be installed in the same orientation and location as removed to preserve the existing alignment and pinion angles.

9. Install the torque rod fasteners securing the torque rod to the lower coil spring bracket and any shims (if equipped) that were removed, see Figure 8-18.
10. Tighten longitudinal torque rod fasteners to 160-200 foot pounds torque.
11. Raise the axle and remove the jack stands.
12. Install the coil springs. See the Coil Spring Assembly procedure in this section, including alignment of the torque box and axle.

AUXILIARY BUMPER

DISASSEMBLY

1. Remove auxiliary bumper mounting fasteners from auxiliary bumper stud, see Figure 8-22.
2. Remove auxiliary bumper from the bottom of the frame rail.

FIGURE 8-22

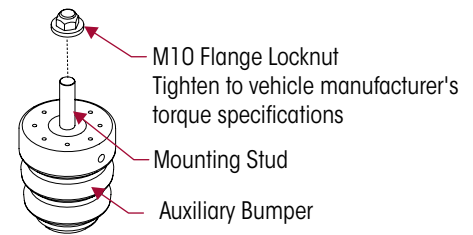

ASSEMBLY

1. Install new auxiliary bumper into position on the bottom of the frame rail.
2. Install fasteners on auxiliary bumper mounting stud, see Figure 8-22.
3. Tighten mounting locknut to vehicle manufacturer's torque specifications.

CROSS MEMBER

DISASSEMBLY

WARNING

COIL SPRING STORED ENERGY

IMPROPER RESTRAINT OF COMPRESSED COIL SPRINGS CAN RESULT IN A VIOLENT SHIFT OF COMPONENTS, AND CAUSE SEVERE PERSONAL INJURY, DEATH AND/OR PROPERTY DAMAGE. FULLY DECOMPRESS OR SECURELY RESTRAIN COMPRESSED COIL SPRINGS BEFORE LOOSENING ANY CLAMP GROUP HARDWARE OR DISASSEMBLING ANY PART OF THE SUSPENSION SYSTEM. DO NOT OPERATE THE VEHICLE WITHOUT COIL SPRINGS FULLY INSTALLED AND RESTRICTED BY OTHER SUSPENSION COMPONENTS.

1. Remove both coil springs. See Coil Spring Disassembly procedure in this section.
2. Raise the axle to ride height and support with jack stands.
3. Support the drive axle pinion with a jack stand.
4. Support the torque box.

SERVICE HINT

It may be helpful to tighten the torque box clamp bolts at the axle to help hold the torque box in position during the disassembly and assembly procedure.

5. Remove the vertical fasteners which connect the torque box to the cross member, see Figure 8-23.
6. Remove the torque box bar pin clamps from the cross member.
7. Remove the cross member C-channel.
8. Remove the fasteners securing the frame hangers to the frame rails per the vehicle manufacturer's recommendations.
9. Remove the cross member gussets, see Figure 8-23.

INSPECTION

1. Inspect the cross member C-channel, gussets, and frame hanger for signs of excessive wear, cracking or damage. Replace as necessary. See the Preventive Maintenance Section of this publication.
2. Inspect the frame rail for signs of wear, cracking or damage. Repair as necessary. Refer to vehicle manufacturer's instructions.

FIGURE 8-23

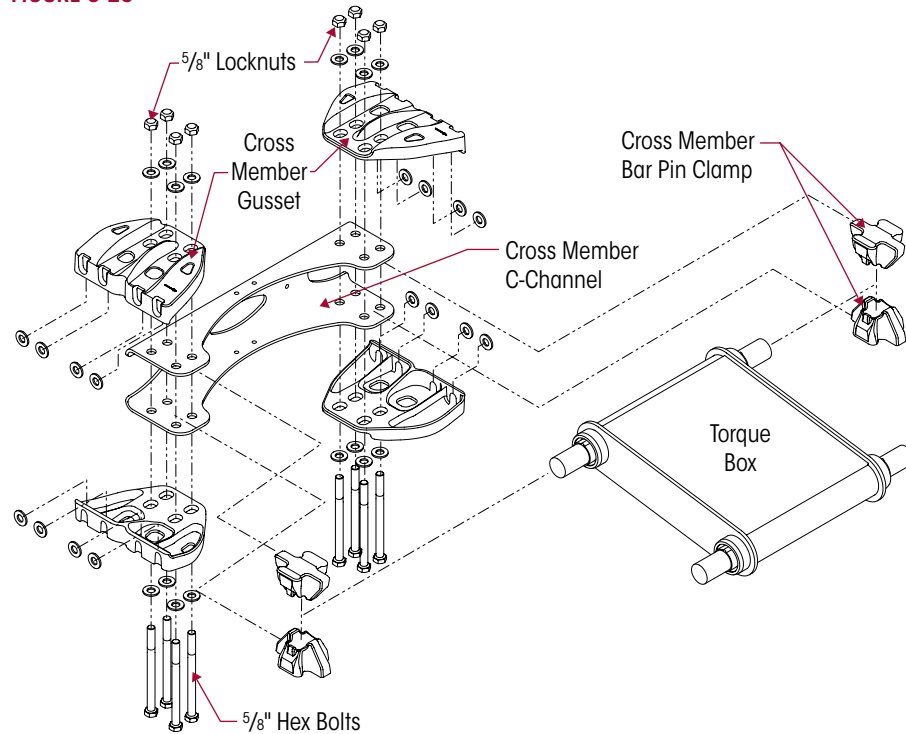
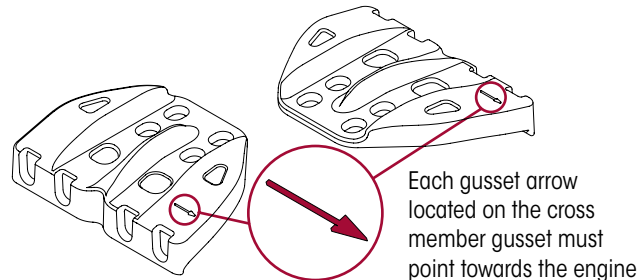

FIGURE 8-24

ASSEMBLY
CAUTION

THE CORRECT GUSSET MUST BE INSTALLED IN THE PROPER POSITION AND ORIENTATION. EACH GUSSET HAS AN ARROW THAT MUST POINT TOWARDS THE ENGINE WHEN INSTALLED, SEE FIGURE 8-24.



1. Position the cross member gussets and frame hangers against the frame rail. Verify the correct cross member gusset is installed in the correct position and the arrow on each cross member gusset must point towards the engine. Loosely install the proper length fasteners through gussets, frame rail, and frame hangers.

NOTE

There are several different length fasteners used to connect the frame hanger to the frame rail. Verify the proper fastener length is used in the proper location. Refer to the vehicle manufacturer's specifications.

2. Position the cross member C-channel between the cross member gussets.
3. Install the torque box clamps onto the torque box bar pin shafts.
4. Install the vertical clamp bolts through the gussets and the cross member C-channel. Ensure the torque box clamps are between the vertical clamp bolts.
5. Tighten the frame hanger to frame fasteners per the vehicle manufacturer's torque specifications.
6. Raise the axle and remove the supports from the axle and pinion.
7. Install the coil springs. See the Coil Spring Assembly procedure in this section, including alignment of the torque box and axle.



SECTION 9 Troubleshooting Guide

HTB 175M FOR WORKHORSE UFO MOTORHOME CHASSIS		
CONDITION	POSSIBLE CAUSE	CORRECTION
Suspension has harsh or bumpy ride	Suspension is overloaded	Redistribute load to the correct weight.
	Torque box not tightened at ride height	See Alignment & Adjustment Section of this publication for proper tightening procedure.
Irregular tire wear	Incorrect tire inflation pressure	Correct tire pressure per the vehicle and tire manufacturer's specifications.
	Axle Alignment	Check vehicle alignment. Adjust if necessary. See the Alignment & Adjustments Section of this publication.
	Worn torque box bushings	Replace torque box as necessary.
	Worn torque rod bushings	Replace torque rod bushings as necessary.
Excessive driveline vibration	Incorrect pinion angle	Adjust pinion angle, refer to the vehicle manufacturer's specifications.
Suspension is noisy	Broken shock or loose shock	Check fasteners for proper torque requirements and inspect for damage. See Preventive Maintenance Section of this publication. Replace as necessary.
	Loose U-bolts	Tighten U-bolts to specifications, see Preventive Maintenance Section of this publication.
	Worn torque rod bushings	Replace torque rod bushings as necessary.
Vehicle bouncing excessively	Damaged or leaking shock absorber	Replace shock absorber.
Vehicle leaning	Incorrect tire inflation pressure	Correct tire pressure per the vehicle manufacturer's and tire manufacturer's specifications.
	Load not centered	Redistribute the load.
	Frame twisted	Straighten the frame per vehicle manufacturer's guidelines.
	Axle housing bent or broken	Replace axle housing per vehicle the manufacturer's guidelines and align vehicle.
	Loose U-bolts	Tighten U-bolts to specifications, see Preventive Maintenance Section of this publication.
	Front suspension	Inspect and repair front suspension.
	Coil spring damaged	Replace coil spring, see Component Replacement Section of this publication.

SECTION 10

Torque Specifications

HENDRICKSON RECOMMENDED TORQUE VALUES
PROVIDED IN FOOT POUNDS

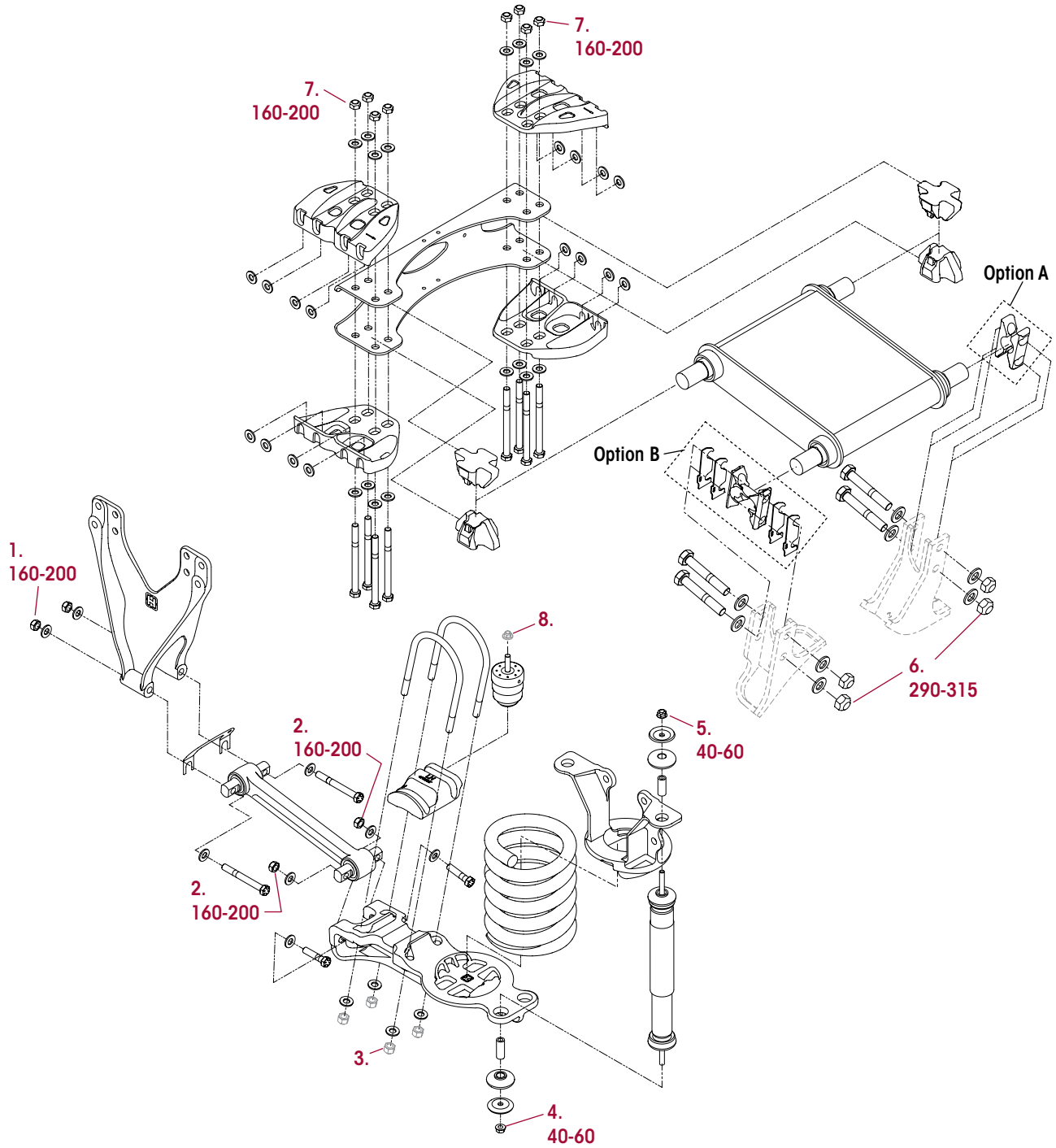



HTB 175M FOR WORKHORSE UFO MOTORHOME CHASSIS				
HENDRICKSON RECOMMENDED TORQUE SPECIFICATIONS				
NO.	COMPONENT	QUANTITY	***SIZE	*TORQUE VALUE in foot pounds
1.	Torque Rod to Frame Hanger	4	5/8"-11 UNC Crown Locknut	160-200
2.	Torque Rod to Lower Coil Spring Bracket	4	5/8"-11 UNC Crown Locknut	160-200
3.	U-bolt to Lower Coil Spring Bracket	8	5/8"-18 UNF U-bolt Tall Nut	***
4.	Shock Absorber to Lower Coil Spring Bracket	2	M12 x 1.75-6H Flange Locknut	40-60
5.	Shock Absorber to Upper Coil Spring Hanger	2	M12 x 1.75-6H Flange Locknut	40-60
6.	Torque Box to Axle Bracket	4	3/4"-10 UNC Crown Locknut	**290-315
7.	Torque Box to Cross Member C-Channel	8	5/8"-11 UNC Crown Locknut	160-200
8.	Auxiliary Bumper	2	M10 x 1.5-6H Flange Locknut	***
<p>NOTE: Current Hendrickson Truck Suspension Systems' U-bolt clamp group hardware for the HTB Mechanical suspension consist of 5/8"-18 UNF Grade C Tall Nuts, 5/8" hardened flat washers and phosphate and oil coated 5/8"-18 UNF Grade 8 U-bolts.</p> <p>* Torque values listed above apply only if Hendrickson supplied fasteners are used. If non Hendrickson fasteners are used, follow torque specification listed in vehicle manufacturer's service manual. Torque calculations based on specific fasteners, using alternate fasteners may alter torque values. See vehicle manufacturer for more information.</p> <p>** See "Final Torque Axle Bracket Clamp Bolts" in the Alignments & Adjustments Section for proper torque procedure.</p> <p>*** Not supplied by Hendrickson. Follow vehicle manufacturer's torque specifications.</p>				

www.hendrickson-intl.com



Truck Commercial Vehicle Systems
800 South Frontage Road
Woodridge, IL 60517-4904 USA

1.866.755.5968 (Toll-free U.S. and Canada)
1.630.910.2800 (Outside U.S. and Canada)
Fax 1.630.910.2899