

- Steer axle systems
- Rear suspension systems



To learn more about Fire and Rescue Products, call 855.743.3733 or visit [www.hendrickson-fire.com](http://www.hendrickson-fire.com)

## Suspension Options

Hendrickson is a leading manufacturer and supplier of premium fire / rescue suspension components to global fire / rescue markets. Our legacy embodies over 100 years as the leading innovator and manufacturer of suspension systems and components for the global transportation industry. Utilizing world class design, testing and validation capabilities, Hendrickson provides robust solutions that feature the ride quality, vehicle handling and stability required for fire / rescue applications around the world.

### **STEERTEK™ NXT**

#### *Fabricated Front Steer Axle System*

- Designed as a platform for next generation front axle and suspension systems
- Full system designed for optimal control under heavy braking
- Compatible with drum and disc brakes
- Two-piece knuckle reduces maintenance and downtime
- Fabricated axle assembly for weight savings vs. traditional forged I-beam axles
- Proprietary threaded pin bushings increase roll stiffness
- Capacity up to 24,000 pounds

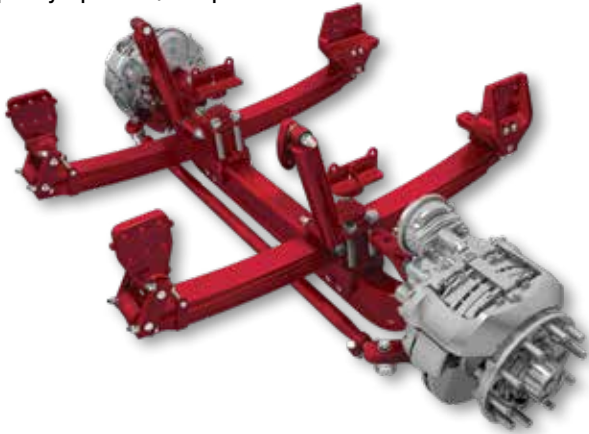

### **RT™ / RTE™**

#### *Steel Leaf Spring Suspension*

- Equalizing beams distribute load equally between both axles for improved traction and lower the center of gravity for increased stability
- Durable steel spring suspension with a legacy of over 85 years of reliability
- Hendrickson-designed springs provide a consistent spring rate for longer spring life
- Capacity up to 65,000 pounds

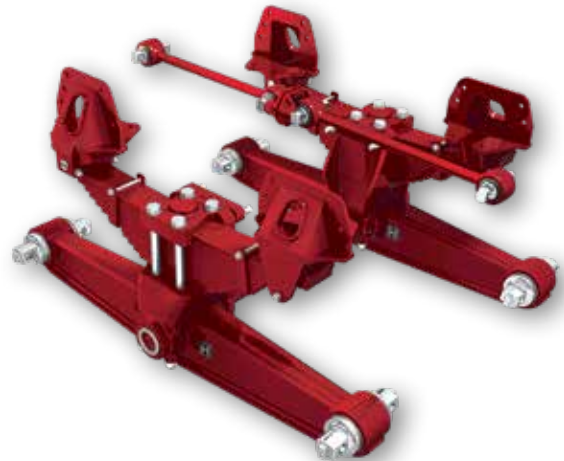

### **HTS**

#### *Mechanical Suspension*

- Single drive axle spring suspension is designed around proven durability, stability and ride quality
- Capacity up to 31,000 pounds

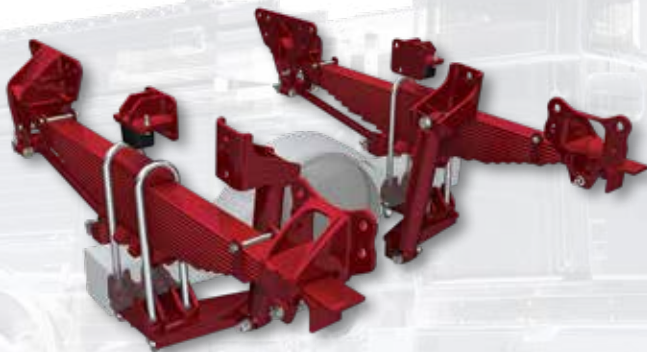

### **ULTIMAAX®**

#### *Advanced Severe-Duty Rubber Suspension 54k - 65k*

- Fabricated walking-beam design equalizes axle loading while providing optimal clearance, axle travel and weight
- Superior ride results in reduced road shock and vibration to the vehicle, which contributes to longer service life of the cab, chassis and body equipment
- Progressive load springs and bar pin end bushing provide extended service life and reduce replacement time
- Capacities up to 65,000 pounds

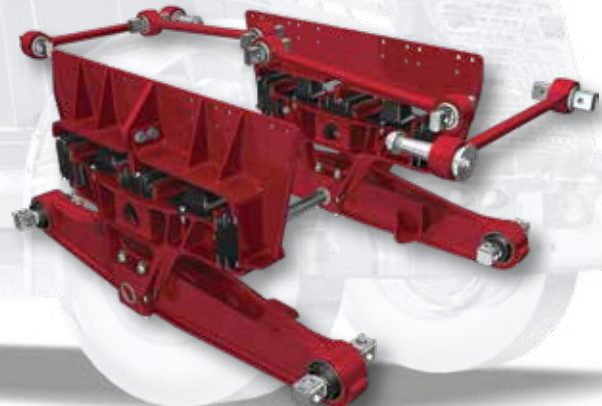



## **HN® FR Series**

### **Rubber Suspensions 40K - 52K**

- HN® FR family of suspensions can be tailored to meet the specific needs of unique vehicle applications
- Elimination of center bushings reduces maintenance
- Bar pin beam end connection extends bushing life and allows axle alignment capability for improved tire life
- Utilizes a VARIRATE® spring system to provide an optimum balance of empty ride quality and loaded stability
- Capacity up to 52,000 pounds



## **FIREMAAX® EX**

### **Heavy-Duty Air Suspension**

- Premium, heavy-duty rubber bushings require no lubrication
- Air springs and shock absorbers designed to package within tire envelope for protection from external damage
- Improved ride for equipment, vehicle and passenger protection
- Exceptional handling for greater control during road maneuvers
- Delivers more than twice the roll stiffness compared to other air suspensions.
- Capacity up to 62,000 pounds



## **ROADMAAX™**

### **Heavy-Duty Air Suspension**

- Provides consistent ride quality with varying vehicle loads
- Optimized configuration provides improved driver feel for increased handling and confidence when performing maneuvers
- Inboard or outboard shock options available
- Featuring TRAAX ROD™ torque rods for exceptional performance life
- Single axle capacities up to 35,000 pounds



## Important Factors to Consider When Selecting a Suspension



### Handling

The vehicle's ability to perform double lane changes, tight turns and other emergency maneuvers.



### Durability / Required Maintenance

Decreased downtime means less time in the repair shop and more time saving lives.



### Ride Quality

The comfort of the driver as well as a reduction in the wear and tear on the vehicle.



### Road and Environmental Conditions

Poor road and extreme environmental conditions have varying effects on suspension systems.



### Chassis / Equipment Protection

Off-highway driving and road debris can expose suspension components to increased wear and tear.



### Loaded to Unloaded Weight Difference

The correct suspension system will maintain excellent quality and performance under a variety of loading condition.

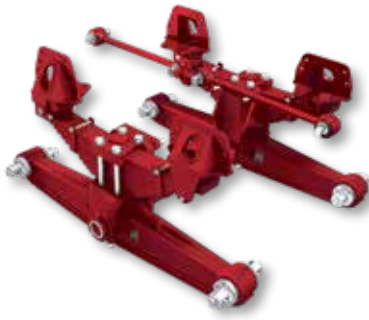

	Rear Leaf Suspension	Rear Rubber Suspension	Rear Air Suspension
Advantages	<ul style="list-style-type: none"> <li>• Low cost</li> <li>• Readily available parts</li> <li>• Good serviceability</li> <li>• Can be used without transverse torque rods</li> </ul>	<ul style="list-style-type: none"> <li>• Lower life cycle cost</li> <li>• Lower maintenance</li> <li>• Durability</li> <li>• Better corrosion protection</li> <li>• Improved ride quality over leaf spring design</li> <li>• Walking beams provide load sharing</li> <li>• Lighter weight than leaf spring design</li> </ul>	<ul style="list-style-type: none"> <li>• Better equipment protection</li> <li>• Better ride quality</li> <li>• Similar ride quality for loaded or empty</li> <li>• Built in side-to-side leveling (no lean)</li> <li>• Maintain constant ride height</li> </ul>
Considerations	<ul style="list-style-type: none"> <li>• Durability and maintenance</li> <li>• Reduced equipment protection</li> <li>• Ride quality</li> <li>• Side to side load balancing may be required</li> <li>• Heavy</li> </ul>	<ul style="list-style-type: none"> <li>• More expensive initial cost than leaf spring designs</li> <li>• Ride quality is less than air suspensions but greater than spring suspensions</li> <li>• Weight sensitive (loaded vs. unloaded)</li> </ul>	<ul style="list-style-type: none"> <li>• More expensive than spring and rubber suspensions</li> <li>• Airbags are susceptible to wear and tear</li> <li>• More complex installation</li> </ul>
Application Suggestions	<ul style="list-style-type: none"> <li>• Areas with roads well maintained</li> <li>• Empty to loaded axle weight is less than 10 percent</li> </ul>	<ul style="list-style-type: none"> <li>• Ideal for harsh road and environment conditions</li> <li>• Empty to loaded axle weight is less than 15 percent</li> </ul>	<ul style="list-style-type: none"> <li>• Ideal for vehicles requiring premium equipment protection</li> <li>• Vehicle with large loaded to unloaded weight differences</li> </ul>

*Actual product performance may vary depending upon vehicle configuration, operation, service and other factors.*

*All applications must comply with applicable Hendrickson specifications and must be approved by the respective vehicle manufacturer with the vehicle in its original, as-built configuration.*

*Contact Hendrickson for additional details regarding specifications, applications, capacities, and operation, service and maintenance instructions.*

Call Hendrickson at **630.910.2800** or **855.RIDERED (743.3733)** for additional information.



#### TRUCK COMMERCIAL VEHICLE SYSTEMS

800 South Frontage Road  
Woodridge, IL 60517-4904 USA  
855.RIDERED (743.3733)  
630.910.2800 • Fax 630.910.2899

www.hendrickson-intl.com

45745-468 Rev A 03-19

© 2018 – 2019 Hendrickson USA, L.L.C. All Rights Reserved. All trademarks shown are owned by Hendrickson USA, L.L.C., or one of its affiliates, in one or more countries.

Information contained in this literature was accurate at the time of publication. Product changes may have been made after the copyright date that are not reflected.

Printed in United States of America