

HENDRICKSON USE ONLY

ORDERING GUIDE

CONNEX[®] ST TRAILER SELF-STEER SUSPENSION SYSTEM

LIT NO: L1251

DATE: December 2020

REVISION: G

FORM INSTRUCTIONS

For complete price and model number information on a CONNEX[®] ST trailer self-steer suspension system, fax this form to 800.696.4416 in the U.S. or 905.789.1033 in Canada. For additional assistance, please call toll-free 866.RIDEAIR (743.3247) in the U.S. or 800.668.5360 in Canada.

TO:		FROM:		COMPANY NAME:	
DATE:	PHONE:	FAX:		EMAIL:	
SAME AS:			EXCEPT:		

CUSTOMER / APPLICATION INFORMATION

OE:	LOCATION:		QUANTITY:
TRAILER TYPE:	TRAILER BEAM OUT-TO-OUT (in):	PRIMARY SUSP. INFO. (i.e. INTRAAX.#):	
TIRE SIZE(S):	TIRE MANUFACTURER:	WHEEL MANUFACTURER:	
WHEEL SIZE:	WHEEL OUTSET (in):	WHEEL INSET (in):	WHEEL PART NUMBER:

SUSPENSION

SUSPENSION MODEL:	CXSL 25K						
RIDE HEIGHT (inches):	<input type="checkbox"/> 13	<input type="checkbox"/> 14	<input type="checkbox"/> 15	<input type="checkbox"/> 16	<input type="checkbox"/> 17	<input type="checkbox"/> 18	<input type="checkbox"/> 19
FRAME BRACKET:	<input type="checkbox"/> Bolt-on	<input type="checkbox"/> Weld-on	<input type="checkbox"/> Weldable Bolt-on				
FRAME BRACKET STYLE:	<input type="checkbox"/> Wingless ¹	<input type="checkbox"/> Winged					
SHOCK ABSORBER:	Standard						
AIR SPRING PSI RANGE²:	<input type="checkbox"/> Standard ³	<input type="checkbox"/> Low Pressure ⁴					
FRAME BRACKET SUPPORT:	<input type="checkbox"/> Weld-on Channel	<input type="checkbox"/> Bolt-on with strut ⁵	<input type="checkbox"/> Customer Supplied		<input type="checkbox"/> Frame Bracket Gusset (Winged only)		
FRAME BRACKET TO BEAM:	<input type="checkbox"/> Assembled		<input type="checkbox"/> Separate Frame kit				
BEAM / AXLE COATING:	<input type="checkbox"/> Standard Black Primer		<input type="checkbox"/> Black Soft-coat				
COMPONENT COATING / COVER: <small>(Frame Brackets and Air Spring Mounts)</small>	<input type="checkbox"/> Standard Black Primer		<input type="checkbox"/> Galvanized		<input type="checkbox"/> None		

1. Only available with weld-on frame brackets.
2. Air spring PSI range does not change overall suspension capacity rating.
3. For load equalization, the standard air spring is to be used with 23K and 25K primary suspension capacities.
4. For load equalization, the low pressure air spring is to be used with 30K primary suspension capacity.
5. Only available with bolt-on frame brackets. Coating will match selected coating on frame brackets.

HENDRICKSON

AXLE	
AXLE:	Leading King Pin Self-steer
STYLE:	Straight
SPINDLE:	HP
 Reference page 5 to help select axle track below.	
TRACK (inches):	<input type="checkbox"/> 77.5 <input type="checkbox"/> 80 <input type="checkbox"/> 83.5 <input type="checkbox"/> 84 <input type="checkbox"/> 85 <input type="checkbox"/> 86
Suspension Beam Center (by track):	30.00" 32.50" 36.00" 36.50" 37.50" 38.5"
WHEEL CUT:	<input type="checkbox"/> 20 degrees <input type="checkbox"/> 25 degrees <input type="checkbox"/> 28 degrees <input type="checkbox"/> 30 degrees
LOCK STRAIGHT MECHANISM:	Standard
TIRE INFLATION SYSTEM ⁶ :	<input type="checkbox"/> TIREMAAX [®] CP (Complete Worksheet on pg. 4) <input type="checkbox"/> TIREMAAX PRO (Complete Worksheet on pg. 4) <input type="checkbox"/> No

DRUM BRAKES *	*Refer to L809 for Drum Brake Certifications.
BRAKE RATING:	<input type="checkbox"/> 20,000 GAWR <input type="checkbox"/> 23,000 GAWR
BRAKE SIZE:	16.5" x 7"
BRAKE MODEL:	HXS [®]
BRAKE COATING:	Standard
BRAKE CHAMBER:	<input type="checkbox"/> Type 30 <input type="checkbox"/> Type 30/30
BRAKE CHAMBER STROKE:	3.0"
BRAKE CHAMBER WARRANTY:	Extended
BRAKE ADJUSTER:	<input type="checkbox"/> 5.5" <input type="checkbox"/> 6.0"
S-CAM:	28 Spline
CAM TUBE SYSTEM:	Standard
DUST SHIELD:	Yes
ABS SENSOR:	<input type="checkbox"/> No <input type="checkbox"/> Haldex (19.7") <input type="checkbox"/> WABCO (15.7") <input type="checkbox"/> Bendix (14.8")

ACCESSORY ITEMS	
SUSPENSION LIFT KIT ⁷ :	<input type="checkbox"/> No <input type="checkbox"/> UBL [™] Painted <input type="checkbox"/> UBL Galvanized

6. Hendrickson does not provide warranty coverage for the installation, performance or components of a competitor brand tire inflation system installed on a Hendrickson suspension. Any consequential damages to the Hendrickson suspension resulting from a failure to the competitor brand tire inflation system or components, whether installed by the OEM, repair facility or end-user customer, should be directed to the respective tire inflation system manufacturer for warranty coverage.
7. If UBL Kit is selected, it will be included with suspension kit. UBL beam brackets will be installed on suspension beams by Hendrickson.

DRUM BRAKE RTR® READY-TO-ROLL® PACKAGES *

*Consult a customer service representative to ensure compatibility of the wheel-end equipment with the other selected suspension parameters.

	<input type="checkbox"/> HXL3® Hendrickson Extended-Life System™ (3-Year Limited Warranty ⁸)	<input type="checkbox"/> HXL5® Hendrickson Extended-Life System™ (5-Year Limited Warranty ⁸)
SPINDLE:	HP	HP
HUB MATERIAL:	<input type="checkbox"/> Ductile Iron <input type="checkbox"/> Dura-Light Hub® <input type="checkbox"/> Aluminum	<input type="checkbox"/> Ductile Iron <input type="checkbox"/> Dura-Light Hub <input type="checkbox"/> Aluminum
HUB STYLE:	Hub Piloted	Hub Piloted
NUMBER OF STUDS:	10	10
BOLT CIRCLE DIAMETER:	11.25"	11.25"
WHEEL MATERIAL:	<input type="checkbox"/> Aluminum <input type="checkbox"/> Steel <input type="checkbox"/> Steel / Aluminum	<input type="checkbox"/> Aluminum <input type="checkbox"/> Steel <input type="checkbox"/> Steel / Aluminum
DUAL / SUPER SINGLE: (SS) Short Stud (LS) Long Stud	<input type="checkbox"/> Dual <input type="checkbox"/> Super Single (SS) <input type="checkbox"/> Super Single (LS)	<input type="checkbox"/> Dual <input type="checkbox"/> Super Single (SS) <input type="checkbox"/> Super Single (LS)
LUBE TYPE:	<input type="checkbox"/> SAE 80/90 <input type="checkbox"/> Synthetic 75W/90	Semi-Fluid Grease
SEAL:	Standard	Standard
BEARING:	Standard	Standard
SPINDLE NUT:	PRECISION320® Nut System	PRECISION320 Nut System
HUBCAP TYPE:	Standard Aluminum Bolt-on	Standard Aluminum Bolt-on
ABS TONE RING:	Yes	Yes

DRUM OPTIONS			
DRUM MATERIAL:	<input type="checkbox"/> Cast – Standard Duty	<input type="checkbox"/> Cast – Heavy Duty	<input type="checkbox"/> Fused – Standard Duty <input type="checkbox"/> None
DRUM BALANCING:	Balanced		
WHEEL FASTENERS:	<input type="checkbox"/> Yes ⁹	<input type="checkbox"/> No	

8 . Refer to Hendrickson publication L583 Comprehensive Warranty Statement for complete details.

9 . Two (2) wheel fasteners factory installed per wheel-end with balance packaged in plastic bag, taped and stretch-wrapped to each wheel-end.

TIREMAAX® KIT WORKSHEET^{6, 10}

TOTAL NUMBER OF TRAILER AXLES (Primaries and liftable / self-steers):	<input type="checkbox"/> 1	<input type="checkbox"/> 2	<input type="checkbox"/> 3	<input type="checkbox"/> 4	<input type="checkbox"/> More than 4						
COLD TIRE PRESSURE SETTING (psi):	Primary Suspension(s): <input type="checkbox"/> 70 <input type="checkbox"/> 75 <input type="checkbox"/> 80 <input type="checkbox"/> 85 <input type="checkbox"/> 90 <input type="checkbox"/> 95 <input type="checkbox"/> 100 <input type="checkbox"/> 105 <input type="checkbox"/> 110 <input type="checkbox"/> 115 <input type="checkbox"/> 120		CONNEX® ST Self-Steer Suspension(s): <input type="checkbox"/> 70 <input type="checkbox"/> 75 <input type="checkbox"/> 80 <input type="checkbox"/> 85 <input type="checkbox"/> 90 <input type="checkbox"/> 95 <input type="checkbox"/> 100 <input type="checkbox"/> 105 <input type="checkbox"/> 110 <input type="checkbox"/> 115 <input type="checkbox"/> 120								
 Verify answer before proceeding.	If the psi settings are different between the primary and CONNEX ST suspensions, a separate L868 TIREMAAX Ordering Guide must be completed for the primary TIREMAAX kit and the below TIREMAAX worksheet must be completed for the CONNEX ST TIREMAAX kit.				Contact Hendrickson Controls at 330-489-1532 for assistance.						
	If the psi settings are the same between the primary and CONNEX ST suspensions, complete the TIREMAAX worksheet below for a single TIREMAAX kit that works for both.										
TIRE HOSE:	<input type="checkbox"/> Standard <input type="checkbox"/> Integral Check Port (22.5" tire size only)										
CONTROLLER TYPE:	<input type="checkbox"/> CP <input type="checkbox"/> PRO										
ELECTRICAL CONNECTION:	<input type="checkbox"/> Delphi Weather Pack (Standard)		<input type="checkbox"/> Blade Terminals ¹¹								
KIT STYLE:	For OEM Install										
AXLE STYLE:	Standard										
AXLE PREPARATION:	TIREMAAX Prepped / Wheel-ends Installed by Hendrickson (Kit includes controller and tire hoses.)										
NUMBER OF AXLES:	<input type="checkbox"/> 1	<input type="checkbox"/> 2	<input type="checkbox"/> 3	<input type="checkbox"/> 4							
SPINDLE STYLE:	HP										
HUBCAP TYPE:	Hendrickson Bolt-on										
LUBE TYPE:	<input type="checkbox"/> Semi-fluid Grease		<input type="checkbox"/> Oil								
TIRE SIZE:	22.5"										
WHEEL STYLE / MATERIAL:	<input type="checkbox"/> Dual / Aluminum		<input type="checkbox"/> Dual / Steel or Combo								
	<input type="checkbox"/> Super Single / Aluminum		<input type="checkbox"/> Super Single / Steel (outboard valve stem)		<input type="checkbox"/> Super Single / Steel (inboard valve stem)						
COLD TIRE PRESSURE SETTING (psi)¹²:	<input type="checkbox"/> 70	<input type="checkbox"/> 75	<input type="checkbox"/> 80	<input type="checkbox"/> 85	<input type="checkbox"/> 90	<input type="checkbox"/> 95	<input type="checkbox"/> 100	<input type="checkbox"/> 105	<input type="checkbox"/> 110	<input type="checkbox"/> 115	<input type="checkbox"/> 120
TRAILER-MOUNTED INDICATOR LIGHT KIT:	<input type="checkbox"/> LED - 12V with 65-foot Cable (Standard)		<input type="checkbox"/> LED - 12V with 35-foot Cable (Standard)			<input type="checkbox"/> LED - 24V (Export ¹³)					
	<input type="checkbox"/> Incandescent - 12V		<input type="checkbox"/> No ¹¹								
WIRING HARNESS:	<input type="checkbox"/> Premium, 15-foot, ABS-ready		<input type="checkbox"/> Premium, 3-foot, ABS-ready			<input type="checkbox"/> Standard, 18-inch, Wiring Adapter Plug					
	<input type="checkbox"/> No ¹¹										
AIR PLUMBING KIT:	<input type="checkbox"/> Manifold ¹⁴		<input type="checkbox"/> None								
CONTROLLER TANK VALVE¹⁵: (Pressure Check)	<input type="checkbox"/> Yes (CP models only)		<input type="checkbox"/> No								

10. When installing TIREMAAX, please contact Hendrickson to verify correct wheel-end component integration.

11. Controllers featuring blade terminals, require the light kit and wiring harness options to be "no".

12. Refer to tire manufacturer's recommended tire pressure. TIREMAAX PRO is restricted to cold tire pressure setting of 85-120 psi.

13. Please note, 12V is used in some export countries. If this is a new venture into a foreign country, please validate voltage requirements with Controls Engineering.

14. Not available for single-axle systems.

15. Not available with TIREMAAX PRO.

AXLE TRACK / TIRE OUT-TO-OUT

For a 96" or 102" wide trailer, the following axle tracks are listed as references for non-steerable suspensions:				
SUSPENSION TYPE	Non-Steerable			
WHEEL STYLE / MATERIAL	Duals / Steel			
WHEEL SIZE: (Diameter x Width x Offset)	22.5 x 8.25 x 6.62		24.5 x 8.25 x 6.62	
TIRE SIZE	11R22.5		11R24.5	
AXLE TRACK	71.5	77.5	71.5	77.5
A (TIRE OUT TO OUT)	96.2	102.2	96.0	102.0

For a 96" wide trailer, the following axle tracks are recommended for steerable suspensions:			
SUSPENSION TYPE	CONNEX ST		
WHEEL STYLE / MATERIAL	Super Single / Aluminum		
WHEEL SIZE: (Diameter x Width x Offset)	22.5 x 12 x 0.56		22.5 x 14 x 0
TIRE SIZE	385 / 65R22.5	425 / 65R22.5	455 / 55R22.5
AXLE TRACK	80.0	77.5	77.5
B (TIRE OUT TO OUT)	95.5	94.5	94.6

For a 102" wide trailer, the following axle tracks are recommended for steerable suspensions:			
SUSPENSION TYPE	CONNEX ST		
WHEEL STYLE / MATERIAL	Super Single / Aluminum		
WHEEL SIZE: (Diameter x Width x Offset)	22.5 x 12 x 0.56		22.5 x 14 x 0
TIRE SIZE	385 / 65R22.5	425 / 65R22.5	455 / 55R22.5
AXLE TRACK	86.0	84.0	85.0
B (TIRE OUT TO OUT)	101.5	101.0	102.1

For a 96" or 102" wide trailer, the following axle tracks are recommended for steerable suspensions:				
SUSPENSION TYPE	CONNEX ST			
WHEEL STYLE / MATERIAL	Duals / Steel			
WHEEL SIZE: (Diameter x Width x Offset)	22.5 x 8.25 x 6.62		24.5 x 8.25 x 6.62	
TIRE SIZE	11R22.5		11R24.5	
AXLE TRACK	71.5	77.5	71.5	77.5
B (TIRE OUT TO OUT)	N/A	102.2	N/A	102.0

NOTE: Please see L1250 CONNEX ST Application Guide for additional information.

Dual Tires

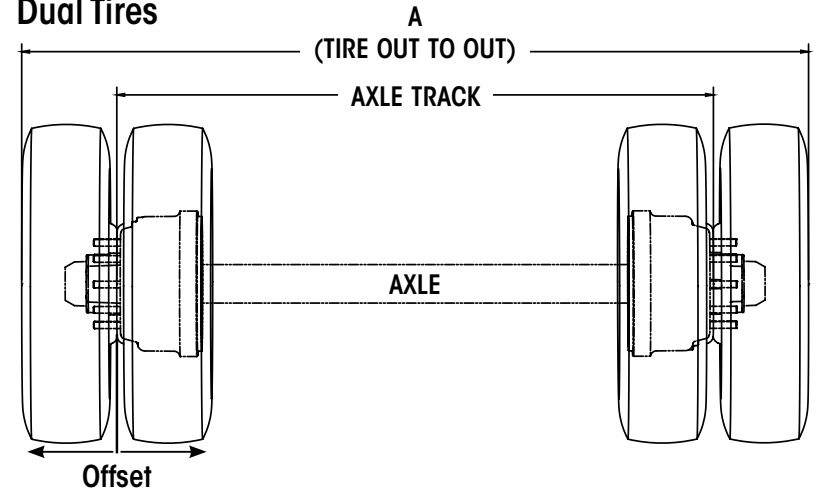

Super Single Tires

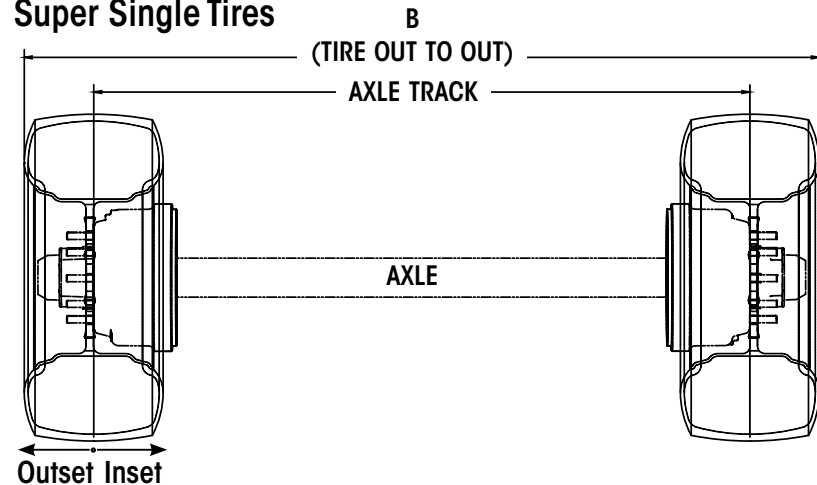

*Actual product performance may vary depending upon vehicle configuration, operation, service and other factors.
All applications must comply with applicable Hendrickson specifications and must be approved by the respective vehicle manufacturer with the vehicle in its original, as-built configuration.
Contact Hendrickson for additional details regarding specifications, applications, capacities, and operation, service and maintenance instructions.*

Call Hendrickson at 330.489.0045 or 866.RIDEAIR (743.3247) for additional information.



www.hendrickson-intl.com

L1251 Rev G 12-20

© 2015 - 2020 Hendrickson USA, L.L.C. All Rights Reserved. All trademarks shown are owned by Hendrickson USA, L.L.C., or one of its affiliates, in one or more countries.
Information contained in this literature was accurate at the time of publication. Product changes may have been made after the copyright date that are not reflected.

TRAILER COMMERCIAL VEHICLE SYSTEMS

2070 Industrial Place SE
Canton, OH 44707-2641 USA
866.RIDEAIR (743.3247)
330.489.0045 • Fax 800.696.4416

Hendrickson Canada

250 Chrysler Drive, Unit #3
Brampton, ON Canada L6S 6B6
800.668.5360
905.789.1030 • Fax 905.789.1033

Hendrickson Mexicana

Circuito El Marqués Sur #29
Parque Industrial El Marqués
Pob. El Colorado, Municipio El Marqués,
Querétaro, México C.P. 76246
+52 (442) 296.3600 • Fax +52 (442) 296.3601