

H PARTS LIST

COMFORT AIR® Rear Air Suspension for Thomas Built Buses

LIT NO: SP-295

DATE: September 2015

REVISION: A

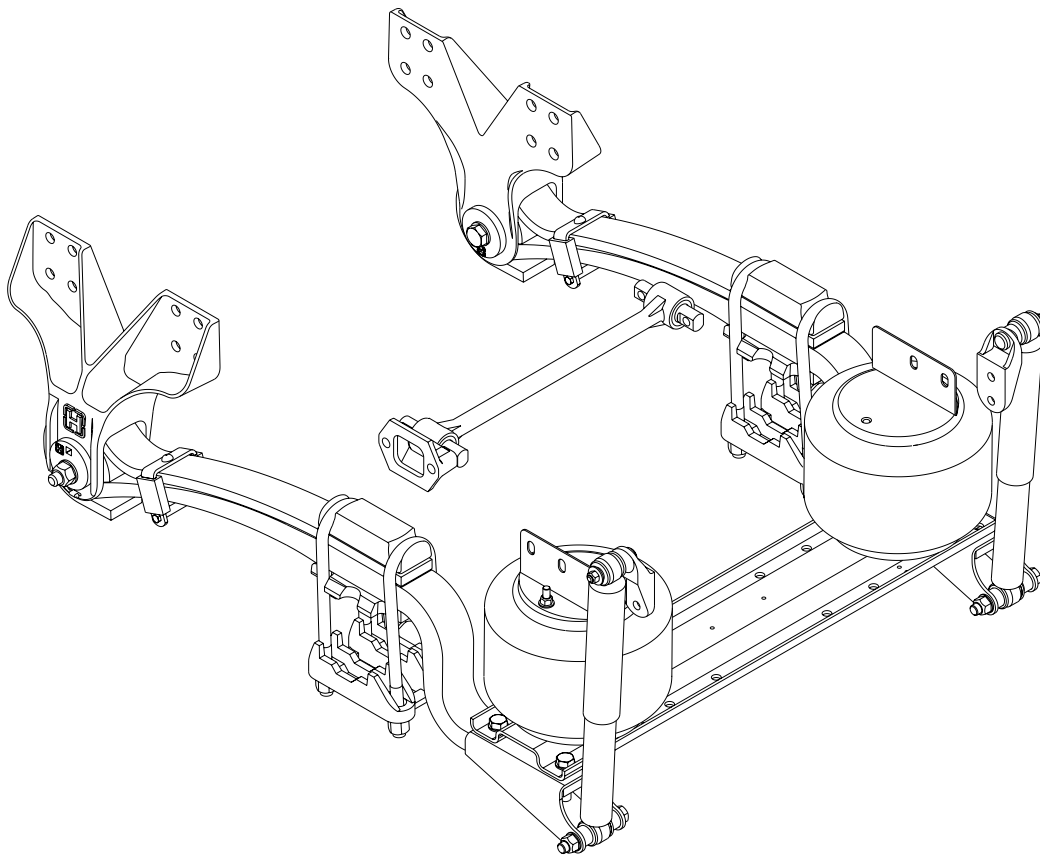

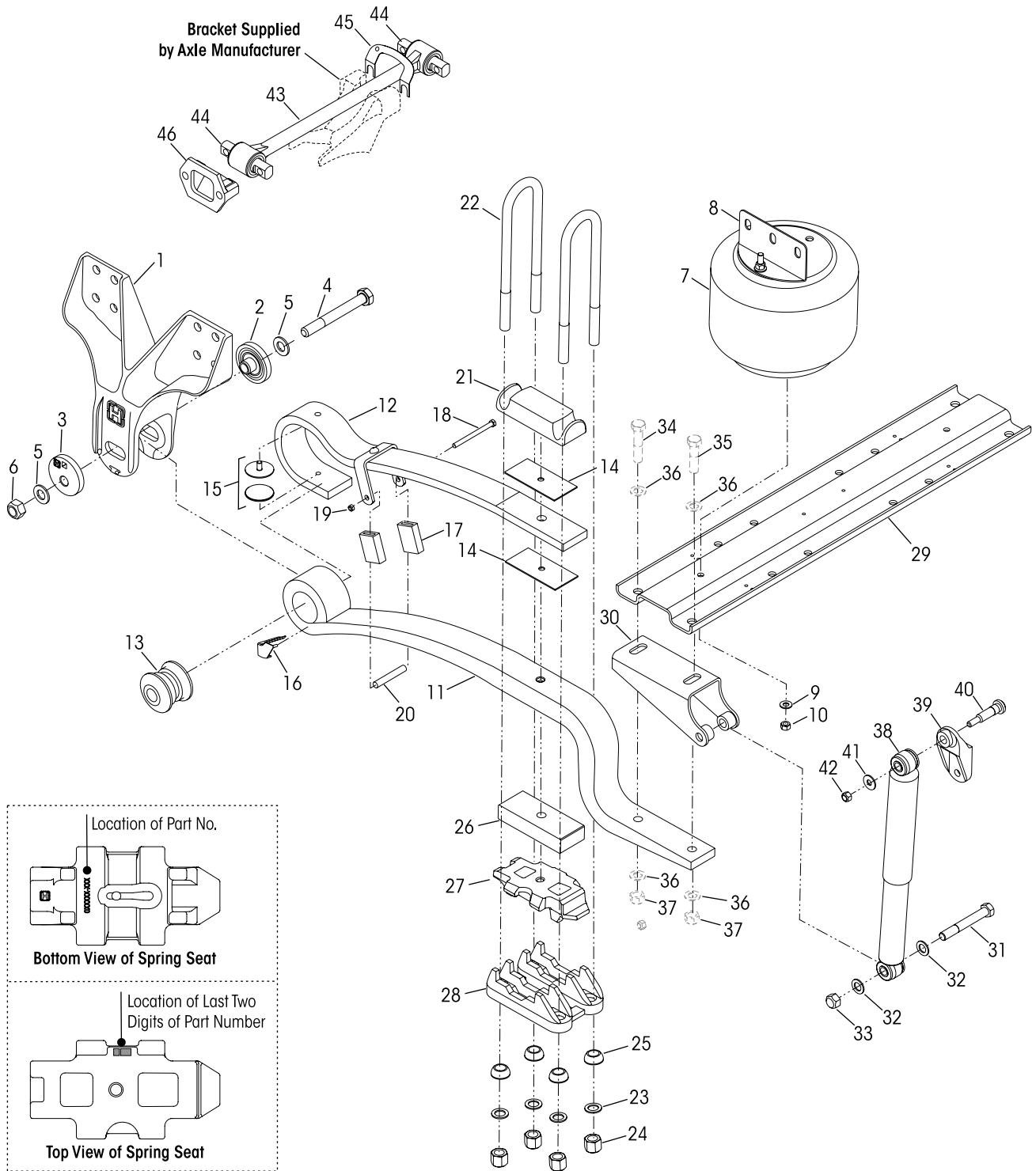



VEHICLE				VEHICLE			
KEY NO.	PART NO.	DESCRIPTION	QTY.	KEY NO.	PART NO.	DESCRIPTION	QTY.
1	60784-000	Frame Hanger	2	21	56805-000	Top Pad	2
	60632-038	QUIK-ALIGN Pivot Bushing Service Kit, Axle Set , Includes Key Nos. 2-6, 13, 15, 47			48718-007	U-bolt Service Kit, Axle Set Includes Key Nos. 22-25	
	34013-103	QUIK-ALIGN Pivot Bushing Service Kit, One Side , Includes Key Nos. 4-6, 13, 15, 47		22	47417-008	5/8"-14 UNF x 1 1/2" U-bolt	4
	60632-013	QUIK-ALIGN® Collar Service Kit, Axle Set , Includes Key Nos. 2-6		23	22962-002	7/8" Hardened Flat Washer	8
2	64633-000	QUIK-ALIGN Concentric Collar	3	24	50765-000	7/8" 14 UNF U-bolt Locknut	8
3	64632-000	QUIK-ALIGN Eccentric Collar	1	25	48574-000	Spherical Washer	8
4	68217-000	1"-8 UNC x 7 1/2" Bolt	2	26	48531-015	Spring Seat Spacer	2
5	68232-000	1" Hardened Washer	4	27	56501-020	Spring Seat, 4.5° Pinion Angle LH/RH - 5"	2
6	68218-000	1"-8 UNC Locknut	2	28	50216-000	Axle Bottom Cap	2
	60925-002	Air Spring Assembly, Includes Key Nos. 7-8 and Fasteners	2	29	66279-001	Cross Channel	1
7		*Air Spring	2		57356-000	Lower Shock Bracket Assembly, Includes Key Nos. 30-33	2
8	57096-002	Air Spring Bracket	2	30		*Lower Shock Bracket	2
	49177-006	Lower Air Spring Fastener Service Kit, Axle Set , Includes Key Nos. 9-10		31	50764-002	3/4"-10 UNC x 5 1/2" Bolt	2
9	22962-014	1/2" Flat Washer	2	32	22962-001	3/4" Hardened Washer	4
10	17700-010	1/2"-13 UNC Nylocknut	2	33	49842-000	3/4"-10 UNC Locknut	2
	60779-000	Main Support Assembly, Includes Key Nos. 11-20	2	34		**3/4"-10 UNC x 3 1/2" Bolt	2
11		*Main Support Member	2	35		**3/4"-10 UNC x 3" Bolt	2
12		*Secondary Leaf	2	36		**3/4" Hardened Washer	8
13	58648-000	Pivot Bushing	2	37		**3/4"-10 UNC Locknut	4
14	37674-051	Liner	4	38	60670-006	Shock Absorber	2
15	64817-000	Plastic Isolator Puck	4		57322-002	Upper Shock Bracket Assembly, Includes Key Nos. 39-42	2
16	60392-000	Spring Eye Clip	2	39		*Upper Shock Bracket	2
	49175-026	Spring Clip Fastener Service Kit, Axle Set , Includes Key Nos. 17-19		40	50368-000	1/2"-13 UNC Serrated Shank Bolt	2
17	64272-004	Spring Clip Sleeve	4	41	22962-031	1/2" Hardened Washer	2
18	37042-006	7/8"-14 UNC Bolt	2	42	49846-000	1/2"-13 UNC Locknut	2
19	37587-000	7/8"-14 UNC Nut	2	43	62000-570	Transverse Torque Rod Assembly	1
20		*Clip Bolt Spacer	2	44	47691-000	Torque Rod Bushing	2
				45	49689-000	Torque Rod Shim	As Req.
				46	22186-000	Transverse Torque Rod Frame Bracket	1
				47	70867-001	P-80 Lubricant - 10 ml (Not Shown)	As Req.

NOTE

* Item included in assembly only, part not sold separately.

** Not supplied by Hendrickson, used for reference only. Refer to vehicle manufacturer for more information. Hendrickson is not responsible for components supplied by vehicle manufacturer.



■ Special Tools

QUIK-ALIGN PIVOT BUSHING TOOL

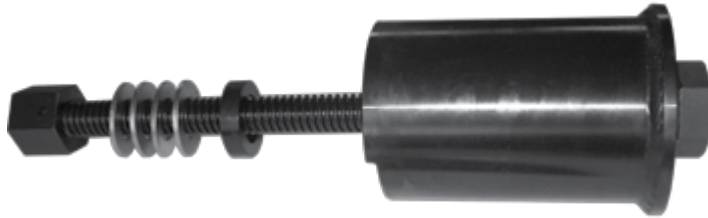

Hendrickson Part No. 66086-203L

Reference Literature No. 59310-061

QUIK-ALIGN SOCKET TOOL



Hendrickson Part No. 66086-200

OTC Part No. 1767

Visit otctools.com

TORQUE ROD BUSHING FUNNEL TOOL

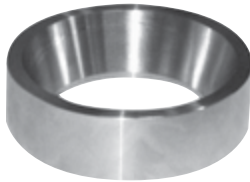

Hendrickson Part No. 66086-001

ULTRA ROD Assembly Funnel Tool

This is a general parts list to provide directional information. Components may vary by model. Questions in regards to parts, contact Hendrickson Truck Parts at 1.866.755.5968 (Toll-free U.S. and Canada), 630.910.2800 (Outside U.S. and Canada) or e-mail: truckparts@hendrickson-intl.com.

Actual product performance may vary depending upon vehicle configuration, operation, service and other factors.

All applications must comply with applicable Hendrickson specifications and must be approved by the respective vehicle manufacturer with the vehicle in its original, as-built configuration.

Contact Hendrickson for additional details regarding specifications, applications, capacities, and operation, service and maintenance instructions.

Call Hendrickson at 1.866.755.5968 (toll-free) or 1.630.910.2800 for additional information.



www.hendrickson-intl.com

TRUCK COMMERCIAL VEHICLE SYSTEMS
 800 South Frontage Road
 Woodridge, IL 60517-4904 USA
 1.866.755.5968 (Toll-free U.S. and Canada)
 1.630.910.2800 (Outside U.S. and Canada)
 Fax 1.630.910.2899

SP-295 Rev C 09-15

© 2015 Hendrickson USA, L.L.C. All Rights Reserved. All trademarks shown are owned by Hendrickson USA, L.L.C., or one of the affiliates, in one or more countries.

Information contained in this literature was accurate at the time of publication. Product changes may have been made after the copyright date that are not reflected.

Printed in United States of America