

H PARTS LIST

INTRAAX® AANL 23K

LIT NO: L1051

DATE: August 2016

REVISION: B



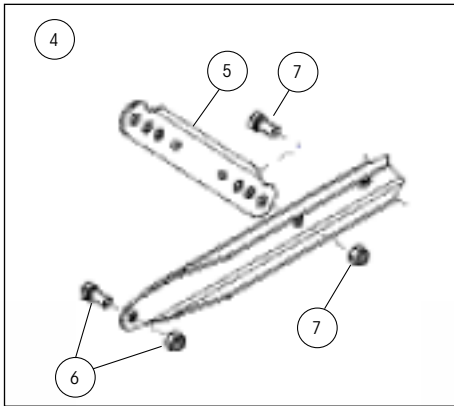

Bolt-on C-channel

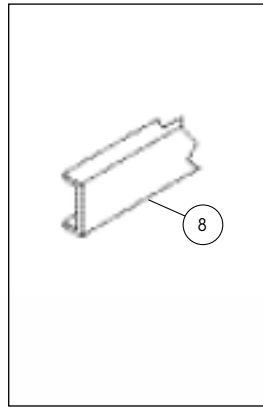

Weld-on C-channel

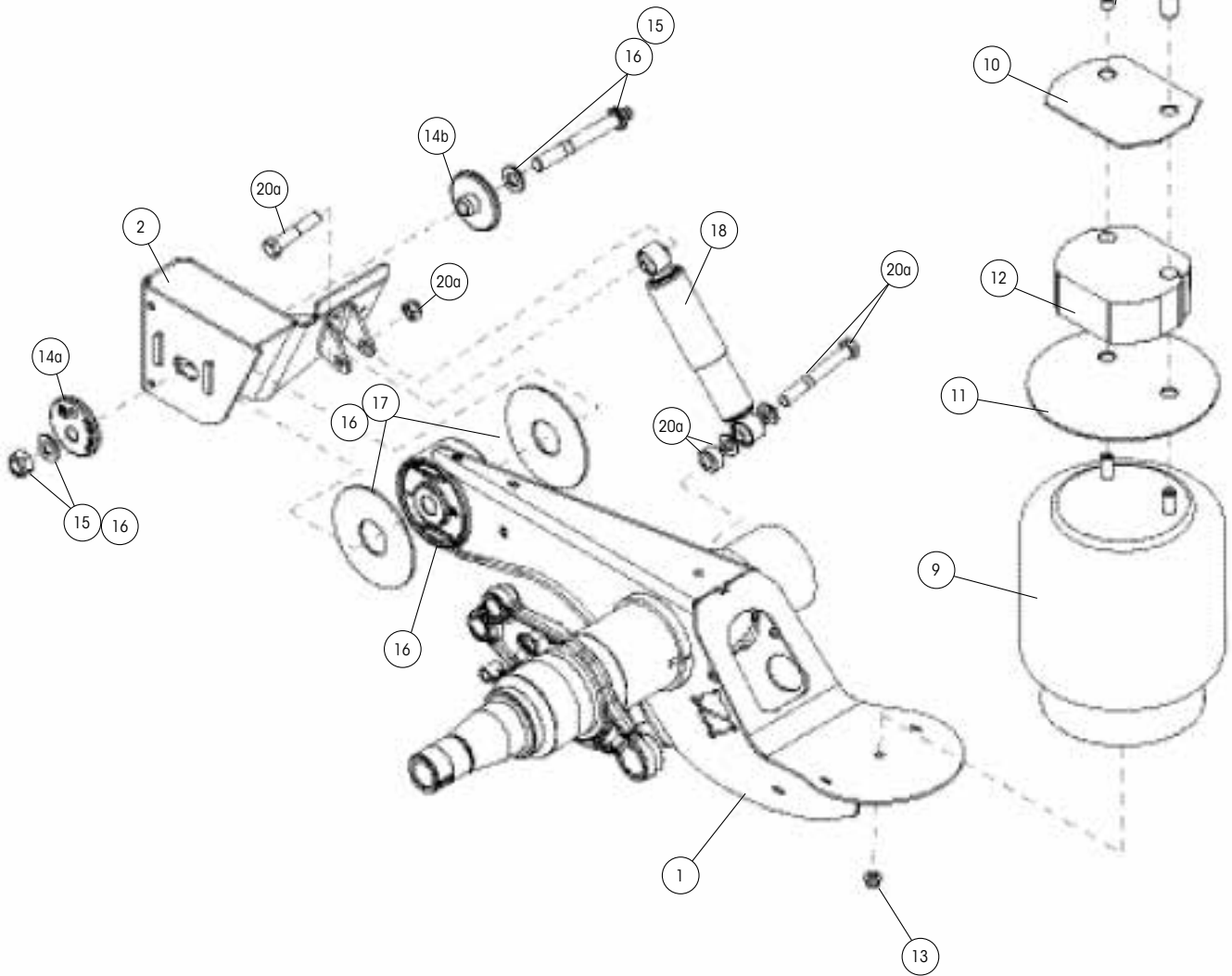

NOTE: Drawing is a general representation of the actual suspension. Not all components are shown.



INTRAAX® AANL 23K PARTS LIST

ITEM	DESCRIPTION	PART NO.	QTY.	NOTE
1	AXLE/BEAM WELDMENT	HTRAAX.XX		Contact Hendrickson for assistance
2	FRAME BRACKET¹			See L1266 Frame Bracket Parts List
3	FRAME BRACKET GUSSET (For winged weld-on) (Not Shown)	S-27330	2	
4	BOLT-ON C-CHANNEL KIT²			
	73.0" Track	S-31901-4C	1	Standard black primer; includes a c-channel, 2 struts and strut bolt kit
	77.5" Track	S-31901-2C	1	Standard black primer; includes a c-channel, 2 struts and strut bolt kit
5	STRUTS²	B-30591	2	12" and 19" ride heights (NA with 6.5" - 9" RH)
6	C-CHANNEL BOLT-KIT	S-29822	1	2 screws and 2 prevailing torque nuts
7	STRUT BOLT-KIT	S-30720	1	6 screws and 6 prevailing torque nuts
8	WELD-ON C-CHANNEL			
	71.5" Track	C-27375-1	1	7" C-Channel
	77.5" Track	C-27375	1	7" C-Channel
9	AIR SPRING			
	Standard Pressure	S-23720	2	6.5" and 7.5" ride heights
		S-23613	2	8" and 9" ride heights
		S-23614	2	12" to 17" ride heights
	Low Pressure	S-23721	2	6.5" and 7.5" ride heights
		S-23611	2	8" and 9" ride heights
		S-23612	2	12" to 17" ride heights
10	AIR SPRING MOUNTING PLATE³	S-20905	2	Weld-On
11	AIR SPRING FLEX PLATE	S-23294	2	Used as mounting plate for 6.5" and 7.5" RH
12	AIR SPRING SPACER			
	Plastic	B-22510-3	2	3-1/8", 15" and 16" ride heights
		B-22510-4	2	3/4", 14" ride height
	Steel (Weld-on)	D-27049-5	2	4-13/16", 17" ride height
13	AIR SPRING MOUNTING KIT			
	6.5" - 12" and 17" - 19" ride heights	S-22619/2	2	Standard frame thickness
	14" ride height	S-22630/2	2	Standard frame thickness
	15" and 16" ride heights	S-22632/2	2	Standard frame thickness
14	ALIGNMENT COLLARS			
	14a Eccentric	S-20925	2	Pivot bolt hole is offset from center of collar
	14b Concentric	S-20924	2	Pivot bolt hole is in center of collar
15	QUIK-ALIGN® PIVOT BOLT KIT⁴	S-24705	2	Pivot bolt, nut and two washers.
16	TRI-FUNCTIONAL® PIVOT BUSHING KIT^{4, 5}	S-26321	1	2 pivot bushings, 2 pivot bolts, nuts, washers, lube pack and bushing tube spacers.
17	BUSHING TUBE SPACERS	S-26807	4	
18	FRONT SHOCK ABSORBER			
	Standard	S-23651	2	6.5" - 9" ride heights
	Extended Service, High Damping	S-24579	2	6.5" - 9" ride heights
		S-25515	2	12" - 17" ride heights
19	REAR SHOCK ABSORBER (Not Shown)			
	Extended Service, High Damping	S-20345	2	6.5" - 7.5" ride heights
		S-25436	2	8" - 12" ride heights
		S-25437	2	14" - 17" ride heights

1. Options exist based on frame attachments, frame bracket style, bolt hole pattern and connection.

Contract Hendrickson for assistance, or refer to L1266 Frame Bracket Parts List.

2. Struts are only optional for bolt-on frame brackets. Other options exist for galvanized or different track widths.

3. Bolt-on air spring mounting plates exist. Please contact Hendrickson for assistance

4. Best installed with Hendrickson's E-20 socket S-24536 (1-inch drive) or S-24303 (3/4-inch).

5. Bushing tool S-24736 is required to correctly rebush the suspension.

NOTE: Identification can be found on the inside of the curbside beam assembly.

Continued on page 4

INTRAAX® AANL 23K PARTS LIST



ITEM	DESCRIPTION	PART NO.	QTY.	NOTE
20	SHOCK BOLT KIT			
	20a Front Shock Absorber	S-29199/2	2	
	20b Rear Shock Absorber (Not Shown)	S-2157/2	2	
21	REAR UPPER SHOCK CLEVIS (Not Shown)			
	6.5" – 7.5", 12" and 15" – 17" ride heights	S-25420	2	
	8" – 9" and 14" ride heights	S-29967	2	
22	REAR SHOCK TOWER (Not Shown)			
	Roadside	S-36122-1	1	
	Curbside	S-36122-2	1	
23	REAR SHOCK TOWER BACKING PLATE (Not Shown)	S-34790	2	
24	REAR SHOCK TOWER BOLT KIT (Not Shown)	S-25449/2	2	4 flange screws and 4 prevailing torque hex nuts
25	AXLE FILTER KIT (Not Shown)			
	HP	S-24960	1	
	HN	S-24963	1	
26	SPINDLE NUT KIT (Not Shown)			
	HP	S-20475/2	2	
	HN	S-20492/2	2	

Actual product performance may vary depending upon vehicle configuration, operation, service and other factors.

All applications must comply with applicable Hendrickson specifications and must be approved by the respective vehicle manufacturer with the vehicle in its original, as-built configuration. Contact Hendrickson for additional details regarding specifications, applications, capacities, and operation, service and maintenance instructions.

Call Hendrickson at **330.489.0045** or **866.RIDEAIR (743.3247)** for additional information.



www.hendrickson-intl.com

TRAILER COMMERCIAL VEHICLE SYSTEMS

2070 Industrial Place SE
Canton, OH 44707-2641 USA
866.RIDEAIR (743.3247)
330.489.0045 • Fax 800.696.4416

Hendrickson Canada

250 Chrysler Drive, Unit #3
Brampton, ON Canada L6S 6B6
800.668.5360
905.789.1030 • Fax 905.789.1033

Hendrickson Mexicana

Circuito El Marqués Sur #29
Parque Industrial El Marqués
Pob. El Colorado, Municipio El Marqués,
Querétaro, México C.P. 76246
+52 (442) 296.3600 • Fax +52 (442) 296.3601

L1051 Rev B 08-16

© 2012 - 2020 Hendrickson USA, L.L.C. All Rights Reserved. All trademarks shown are owned by Hendrickson USA, L.L.C., or one of its affiliates, in one or more countries. Information contained in this literature was accurate at the time of publication. Product changes may have been made after the copyright date that are not reflected.

Printed in United States of America