



H TECHNICAL PROCEDURE

PRIMAAX® EX Tridem Rear Suspension for Mack Heavy Dump Truck (HDT) Vehicles

SUBJECT: Service Instructions

LIT NO: 17730-329

DATE: June 2020

REVISION: A

TABLE OF CONTENTS

Section 1	Introduction	2	Section 8	Component Replacement	
Section 2	Product Description	2		Fasteners	29
Section 3	Important Safety Notice	4		Air Spring / Upper Air Spring Bracket	29
Section 4	Parts Lists	8		Height Control Valve	31
Section 5	Special Tools	12		Shock Absorber	32
Section 6	Preventive Maintenance			Transverse Torque Rod	32
	Hendrickson Recommended			Longitudinal Torque Rod	33
	Inspection Intervals	13		U-beam Assembly	34
	Component Inspection	14		D-pin Bushing	37
	U-bolt locknuts	15		QUIK-ALIGN Pivot Bushing	40
	Pivot Bushing and D-Pin Bushing Inspection	16		Top Pad	44
	Longitudinal and Transverse Torque Rods	18		Bottom Cap	46
	Air Fitting Inspection	18		Axle Stops	48
	Shock Absorber Inspection	19		Frame Hanger	48
Section 7	Alignment & Adjustments		Section 9	Plumbing Diagram	51
	Ride Height – Dual Height Control Valves	21	Section 10	Torque Specifications	52
	Drive Axle Alignment Inspection	23	Section 11	Troubleshooting Guide	54
	Axle Pinion Angle	25			
	Axle Lateral Alignment	25			
	Alignment Adjustment Instructions	26			
	Pinion Angle Adjustment	28			

SECTION 1

Introduction

This publication is intended to acquaint and assist maintenance personnel in the preventive maintenance, service, repair, and rebuild of PRIMAAX® EX tridem suspension system on applicable Mack Heavy Dump Truck (HDT) Vehicles.

NOTE

Use only Hendrickson Genuine parts for servicing this suspension system.

It is important to read and understand the entire Technical Procedure publication prior to performing any maintenance, service, repair, or rebuild of this product. The information in this publication contains parts lists, safety information, product specifications, features, proper maintenance, service, repair and rebuild instructions for the PRIMAAX EX tridem suspension.

Hendrickson reserves the right to make changes and improvements to its products and publications at any time. Contact Hendrickson Tech Services for information on the latest version of this manual at 1-866-755-5968 (toll-free U.S. and Canada), 630-910-2800 (outside U.S. and Canada) or e-mail: techservices@hendrickson-intl.com.

The latest revision of this publication is also available online at www.hendrickson-intl.com.

SECTION 2

Product Description

FIGURE 2-1

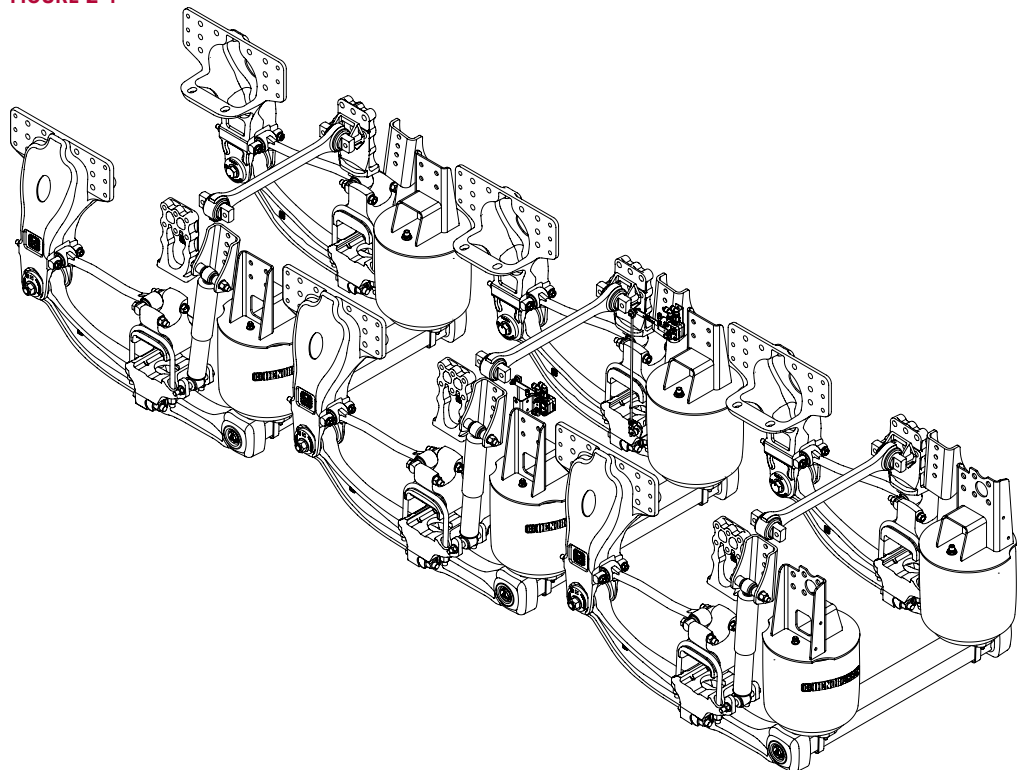



PRIMAAX EX

MAAXimize the performance of vocational and heavy-haul vehicles with a suspension engineered specifically for demanding on- and off- road conditions. With over a 100 years of robust suspension design, Hendrickson delivers another premium suspension with PRIMAAX EX. Rugged, dependable and extensively tested in challenging applications, PRIMAAX EX paves a new road for suspension technology. Drivers, cargo and vehicles are major investments that require protection. PRIMAAX EX adjusts to variations in load and road conditions for optimal ride and performance. This low-maintenance design delivers greater stability for improved control on and off the job site.

- **Unique suspension geometry** — Optimized configuration significantly controls suspension windup and corresponding frame rise, while increasing roll stiffness and reducing roll steer.
- **Easy axle alignment** — Hendrickson's proven QUIK-ALIGN® axle alignment system helps save time and money and offers a fast method to ensure proper alignment for improved tire life.
- **D-pin axle connection and clamp group** — Reduces stress input to the axle housing by transferring the torsional loads to the integrated stabilizer system, which helps extend axle and joint service life.
- **Large volume air springs** — Reduce noise, vibration and harshness to cab, chassis and body equipment for reduced total vehicle maintenance; new integrated pistons and spacers provide a more robust beam connection while lifting and supporting the load with less air pressure.
- **Frame Hanger** — New, more robust design to meet a variety of grueling vocational and severe-duty applications.
- **Structural beam end joint** — Maintenance-free connection with cross brace reduces downtime for improved productivity.
- **Cast structural beams** — Redesigned beams utilize premium materials to improve durability.
- **Heavy-duty shock absorbers** — Positioned and tuned for optimum damping characteristics and to protect air springs from over-extension.
- **Torque Rods** — Three-rod configuration reduces axle stress, welding and complexity. Optimized configuration helps improve handling and roll stiffness for expanded applications. Premium retained rubber bushings for increased service life and resistance to walkout. Designed for optimum clearance and articulation. Alternative rods available for disc brake use.

SECTION 3

Important Safety Notice

Proper maintenance, service and repair are important to the reliable operation of the suspension. The procedures recommended by Hendrickson and described in this technical publication are methods of performing such maintenance, service and repair.

This technical publication should be read carefully to help prevent personal injury and to assure that proper methods are used. Improper maintenance, service or repair may damage the vehicle, cause personal injury, render the vehicle unsafe in operation, or void the manufacturer's warranty.

Failure to follow the safety precautions in this manual can result in personal injury and/or property damage. Carefully read and understand all safety related information within this publication, on all decals and in all such materials provided by the vehicle manufacturer before conducting any maintenance, service or repair.

■ EXPLANATION OF SIGNAL WORDS

Hazard "Signal Words" (Danger • Warning • Caution) appear in various locations throughout this publication. Information accented by one of these signal words must be observed to help minimize the risk of personal injury to service personnel, or possibility of improper service methods which may damage the vehicle or render it unsafe.



This is the safety alert symbol. It is used to alert you to potential personal injury hazards. Obey all safety messages that follow this symbol to avoid possible injury or death.

Additional Notes or Service Hints are utilized to emphasize areas of procedural importance and provide suggestions for ease of repair. The following definitions indicate the use of these signal words as they appear throughout the publication.



INDICATES AN IMMINENTLY HAZARDOUS SITUATION, WHICH IF NOT AVOIDED, WILL RESULT IN SERIOUS INJURY OR DEATH.



INDICATES A POTENTIAL HAZARDOUS SITUATION WHICH, IF NOT AVOIDED, CAN RESULT IN SERIOUS INJURY OR DEATH.



INDICATES A POTENTIAL HAZARDOUS SITUATION WHICH, IF NOT AVOIDED, MAY RESULT IN MINOR OR MODERATE INJURY.

NOTE

An operating procedure, practice condition, etc. which is essential to emphasize.

SERVICE HINT

A helpful suggestion that will make the servicing being performed a little easier and/or faster.

Also note that particular service operations may require the use of special tools designed for specific purposes. These special tools can be found in the "Special Tools" Section of this publication.



The torque symbol alerts you to tighten fasteners to a specified torque value. Refer to Torque Specifications Section of this publication.



■ SAFETY PRECAUTIONS



WARNING

LOAD CAPACITY

ADHERE TO THE PUBLISHED CAPACITY RATINGS FOR THE SUSPENSION. ADD-ON AXLE ATTACHMENTS AND OTHER LOAD TRANSFERRING DEVICES, SUCH AS LIFTABLE AXLES, CAN INCREASE THE SUSPENSION LOAD ABOVE ITS RATED AND APPROVED CAPACITIES, WHICH CAN RESULT IN COMPONENT DAMAGE AND ADVERSE VEHICLE HANDLING, POSSIBLY CAUSING PERSONAL INJURY OR PROPERTY DAMAGE.



WARNING

FASTENERS

DISCARD USED FASTENERS. ALWAYS USE NEW FASTENERS TO COMPLETE A REPAIR. FAILURE TO DO SO COULD RESULT IN FAILURE OF THE PART, OR MATING COMPONENTS, ADVERSE VEHICLE HANDLING, PERSONAL INJURY, OR PROPERTY DAMAGE.

LOOSE OR OVER TORQUED FASTENERS CAN CAUSE COMPONENT DAMAGE, ADVERSE VEHICLE HANDLING, PROPERTY DAMAGE, OR SEVERE PERSONAL INJURY. MAINTAIN CORRECT TORQUE VALUE AT ALL TIMES. CHECK TORQUE VALUES ON A REGULAR BASIS AS SPECIFIED, USING A REGULARLY CALIBRATED TORQUE WRENCH. TORQUE VALUES SPECIFIED IN THIS TECHNICAL PUBLICATION ARE FOR HENDRICKSON SUPPLIED FASTENERS ONLY. IF NON HENDRICKSON FASTENERS ARE USED, FOLLOW TORQUE SPECIFICATION LISTED IN THE VEHICLE MANUFACTURER'S SERVICE MANUAL.



WARNING

QUIK-ALIGN FASTENERS

DISCARD USED QUIK-ALIGN FASTENERS. ALWAYS USE NEW QUIK-ALIGN FASTENERS TO COMPLETE A REPAIR. FAILURE TO DO SO COULD RESULT IN FAILURE OF THE PART, OR MATING COMPONENTS, ADVERSE VEHICLE HANDLING, PERSONAL INJURY, OR PROPERTY DAMAGE.

DO NOT ASSEMBLE QUIK-ALIGN JOINT WITHOUT THE PROPER FASTENERS. USE ONLY H-COATED FASTENERS TO SUSTAIN PROPER CLAMP FORCE. FAILURE TO DO SO CAN CAUSE ADVERSE VEHICLE HANDLING, PROPERTY DAMAGE OR PERSONAL INJURY AND VOID WARRANTY. ENSURE THAT THE QUIK-ALIGN FASTENER'S TORQUE VALUES ARE SUSTAINED AS RECOMMENDED IN THE TORQUE SPECIFICATIONS SECTION OF THIS PUBLICATION. FAILURE TO DO SO CAN CAUSE ADVERSE VEHICLE HANDLING RESULTING IN PERSONAL INJURY OR PROPERTY DAMAGE. FOLLOW VEHICLE MANUFACTURER'S FASTENER ORIENTATION WHEN PERFORMING ANY MAINTENANCE, SERVICE OR REPAIR.



WARNING

MODIFYING COMPONENTS

DO NOT MODIFY OR REWORK PARTS WITHOUT AUTHORIZATION FROM HENDRICKSON. DO NOT SUBSTITUTE REPLACEMENT COMPONENTS NOT AUTHORIZED BY HENDRICKSON. USE OF MODIFIED, REWORKED, SUBSTITUTE OR REPLACEMENT PARTS NOT AUTHORIZED BY HENDRICKSON MAY NOT MEET HENDRICKSON'S SPECIFICATIONS, AND CAN RESULT IN FAILURE OF THE PART, ADVERSE VEHICLE HANDLING, POSSIBLE PERSONAL INJURY OR PROPERTY DAMAGE, AND WILL VOID ANY APPLICABLE WARRANTIES. USE ONLY HENDRICKSON AUTHORIZED REPLACEMENT PARTS.



CAUTION

PROCEDURES AND TOOLS

A TECHNICIAN USING A SERVICE PROCEDURE OR TOOL WHICH HAS NOT BEEN RECOMMENDED BY HENDRICKSON MUST FIRST SATISFY HIMSELF THAT NEITHER HIS SAFETY NOR THE VEHICLE'S SAFETY WILL BE JEOPARDIZED BY THE METHOD OR TOOL SELECTED. INDIVIDUALS DEVIATING IN ANY MANNER FROM THE INSTRUCTIONS PROVIDED WILL ASSUME ALL RISKS OF CONSEQUENTIAL PERSONAL INJURY OR DAMAGE TO EQUIPMENT INVOLVED.



WARNING

WORK SITE DUMPING

WHEN THE TRUCK/TRAILER BODY/BOOM/AND OR ATTACHMENT IS LIFTED IT IS MANDATORY TO COMPLETELY EXHAUST THE AIR FROM THE SUSPENSION SYSTEM TO HELP PROVIDE STABILITY WHEN LIFTED. FAILURE TO DO SO CAN RESULT IN LOSS OF VEHICLE CONTROL, ROLL-OVER, OR VEHICLE INSTABILITY, POSSIBLY CAUSING SEVERE PERSONAL INJURY, PROPERTY DAMAGE, OR DEATH. FIRST RAISE ANY AUXILIARY AXLES AND THEN EXHAUST ALL PRESSURE FROM REAR TRACTOR / TRAILER AND TRUCK AIR SUSPENSION SYSTEMS PRIOR TO RAISING THE BODY / BOOM OR ATTACHMENTS. FOLLOW THE VEHICLE MANUFACTURER'S OPERATING INSTRUCTIONS FOR MAINTAINING PROPER STABILITY.



 **WARNING****TORCH/WELDING**

DO NOT USE A CUTTING TORCH TO REMOVE ANY FASTENERS. THE USE OF HEAT ON SUSPENSION COMPONENTS WILL ADVERSELY AFFECT THE STRENGTH OF THESE PARTS. A COMPONENT DAMAGED IN THIS MANNER CAN RESULT IN THE ADVERSE VEHICLE HANDLING AND POSSIBLE PERSONAL INJURY OR PROPERTY DAMAGE.

EXERCISE EXTREME CARE WHEN HANDLING OR PERFORMING MAINTENANCE IN THE AREA OF THE SUPPORT BEAM. DO NOT CONNECT ARC WELDING GROUND LINE TO THE SUPPORT BEAM. DO NOT STRIKE AN ARC WITH THE ELECTRODE ON THE SUPPORT BEAM. DO NOT USE HEAT NEAR THE SUPPORT BEAM ASSEMBLY. DO NOT NICK OR GOUGE THE SUPPORT BEAM. SUCH IMPROPER ACTIONS CAN DAMAGE THE SUPPORT BEAM ASSEMBLY AND CAUSE ADVERSE VEHICLE HANDLING AND POSSIBLE PERSONAL INJURY OR PROPERTY DAMAGE.

 **CAUTION****AIR SPRING LOWER MOUNTING STUDS**

IF THE AIR SPRING IS BEING REMOVED FOR AN ALTERNATE REPAIR, IT IS MANDATORY TO LUBRICATE THE LOWER AIR SPRING FASTENERS WITH PENETRATING OIL AND REMOVE WITH HAND TOOLS TO PREVENT DAMAGE TO THE LOWER AIR SPRING MOUNTING STUD. FAILURE TO DO SO CAN CAUSE COMPONENT DAMAGE AND VOID WARRANTY.

 **WARNING****AIR SPRING PRESSURE RETENTION**

SOME VEHICLE APPLICATIONS, SUCH AS VEHICLES EQUIPPED WITH OUTRIGGERS, RETAIN SOME AIR PRESSURE IN THE AIR SPRINGS AT ALL TIMES. PRIOR TO PERFORMING ANY MAINTENANCE, SERVICE, OR REPAIR OF THE SUSPENSION, VERIFY EACH AIR SPRING IS COMPLETELY DEFLATED. FAILURE TO DO SO COULD RESULT SERIOUS PROPERTY DAMAGE AND/OR SEVERE PERSONAL INJURY.

 **WARNING**

FAILURE TO PRESS THE AIR SPRING AGAINST THE UNDERSIDE OF THE FRAME WHILE TIGHTENING THE UPPER AIR SPRING BRACKET CAN RESULT IN COMPONENT DAMAGE AND PERSONAL INJURY OR PROPERTY DAMAGE.

 **WARNING****AIR SPRING INFLATION AND DEFLATION**

PRIOR TO DISASSEMBLY OF THE SUSPENSION, AIR SPRING ASSEMBLIES MUST BE DEFLATED. UNRESTRICTED AIR SPRING ASSEMBLIES CAN VIOLENTLY SHIFT. DO NOT INFLATE AIR SPRING ASSEMBLIES WHEN THEY ARE UNRESTRICTED. AIR SPRING ASSEMBLIES MUST BE RESTRICTED BY SUSPENSION OR OTHER ADEQUATE STRUCTURE. DO NOT INFLATE BEYOND PRESSURES RECOMMENDED BY AIR SPRING MANUFACTURER, CONTACT HENDRICKSON TECHNICAL SERVICES FOR DETAILS. IMPROPER USE OR OVER INFLATION MAY CAUSE AIR SPRING ASSEMBLIES TO BURST, CAUSING PROPERTY DAMAGE AND/OR SEVERE PERSONAL INJURY.

PRIOR TO AND DURING DEFLATION AND INFLATION OF THE AIR SUSPENSION SYSTEM, ENSURE ALL PERSONNEL AND EQUIPMENT ARE CLEAR FROM UNDER THE VEHICLE AND AROUND THE SERVICE AREA, FAILURE TO DO SO CAN CAUSE SERIOUS PERSONAL INJURY, DEATH, OR PROPERTY DAMAGE.

 **CAUTION****AIR SPRING INFLATION**

INFLATE THE SUSPENSION SLOWLY AND MAKE SURE THE RUBBER BLADDER OF THE AIR SPRING INFLATES UNIFORMLY AND IS NOT BINDING. FAILURE TO DO SO CAN CAUSE DAMAGE TO THE AIR SPRING AND/OR MOUNTING BRACKETS AND VOID WARRANTY.

 **WARNING****SHOCK ABSORBERS**

THE SHOCK ABSORBERS ARE THE REBOUND TRAVEL STOPS FOR THE SUSPENSION. ANYTIME THE AXLE ON A PRIMAAX EX SUSPENSION IS SUSPENDED IT IS MANDATORY THAT THE SHOCK ABSORBERS REMAIN CONNECTED. FAILURE TO DO SO CAN CAUSE THE AIR SPRINGS TO SEPARATE FROM THE PISTON AND RESULT IN PREMATURE AIR SPRING FAILURE. REPLACEMENT OF SHOCK ABSORBERS WITH NON-HENDRICKSON PARTS CAN ALTER THE REBOUND TRAVEL OF THE SUSPENSION.

 **WARNING****TRANSVERSE RODS**

PRIMAAX EX SUSPENSIONS INCORPORATE TRANSVERSE RODS FOR VEHICLE STABILITY. IF THESE COMPONENTS ARE DISCONNECTED OR ARE NON-FUNCTIONAL, THE VEHICLE SHOULD NOT BE OPERATED. FAILURE TO DO SO CAN RESULT IN ADVERSE VEHICLE HANDLING, POSSIBLE TIRE CONTACT WITH THE FRAME, PREMATURE COMPONENT DAMAGE, OR SEVERE PERSONAL INJURY.



SUPPORT THE VEHICLE PRIOR TO SERVICING

PLACE THE VEHICLE ON A LEVEL FLOOR AND CHOCK THE WHEELS TO PREVENT THE VEHICLE FROM MOVING OR ROLLING. DO NOT WORK AROUND OR UNDER A RAISED VEHICLE SUPPORTED BY ONLY A FLOOR JACK OR OTHER LIFTING DEVICE. ALWAYS SUPPORT A RAISED VEHICLE WITH RIGID SAFETY STANDS. FAILURE TO DO SO CAN CAUSE SERIOUS PERSONAL INJURY OR DAMAGE TO EQUIPMENT.



PERSONAL PROTECTIVE EQUIPMENT

ALWAYS WEAR PROPER EYE PROTECTION AND OTHER REQUIRED PERSONAL PROTECTIVE EQUIPMENT TO HELP PREVENT PERSONAL INJURY WHEN PERFORMING VEHICLE MAINTENANCE, REPAIR OR SERVICE.



PARTS CLEANING

SOLVENT CLEANERS CAN BE FLAMMABLE, POISONOUS, AND CAUSE BURNS. TO HELP AVOID SERIOUS PERSONAL INJURY, CAREFULLY FOLLOW THE MANUFACTURER'S PRODUCT INSTRUCTIONS AND GUIDELINES AND THE FOLLOWING PROCEDURES:

1. WEAR PROPER EYE PROTECTION.
2. WEAR CLOTHING THAT PROTECTS YOUR SKIN.
3. WORK IN A WELL-VENTILATED AREA.
4. DO NOT USE GASOLINE OR SOLVENTS THAT CONTAIN GASOLINE. GASOLINE CAN EXPLODE.
5. HOT SOLUTION TANKS OR ALKALINE SOLUTIONS MUST BE USED CORRECTLY. FOLLOW THE MANUFACTURER'S RECOMMENDED INSTRUCTIONS AND GUIDELINES CAREFULLY TO HELP PREVENT PERSONAL ACCIDENT OR INJURY.

DO NOT USE HOT SOLUTION TANKS OR WATER AND ALKALINE SOLUTIONS TO CLEAN GROUND OR POLISHED PARTS. DOING SO WILL CAUSE DAMAGE TO THE PARTS AND VOID WARRANTY.



CROSS TUBE

IMPROPER JACKING METHODS CAN CAUSE STRUCTURAL DAMAGE (SEE SAFETY DECAL, FIGURE 3-2) AND RESULT IN ADVERSE VEHICLE HANDLING, SEVERE PERSONAL INJURY OR DEATH AND WILL VOID HENDRICKSON'S WARRANTY.

FIGURE 3-2 Safety Decal Number 60905-015

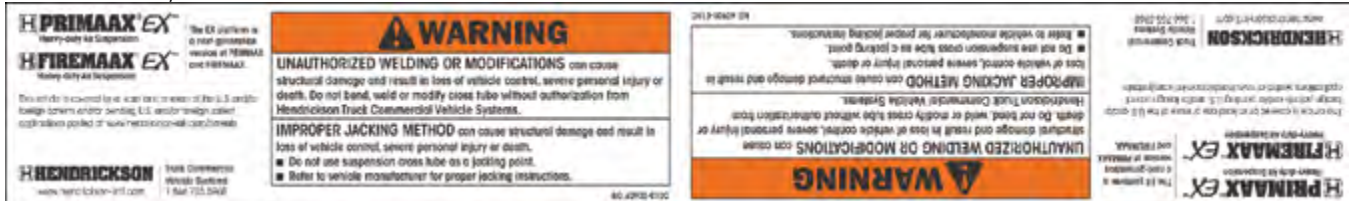

- REPLACE ANY SAFETY DECALS THAT ARE FADED, TORN, MISSING, ILLEGIBLE, OR OTHERWISE DAMAGED. CONTACT HENDRICKSON TO ORDER REPLACEMENT LABELS
- DO NOT USE THE SUSPENSION CROSS TUBE AS A JACKING POINT TO RAISE THE VEHICLE, SEE FIGURE 3-3
- REFER TO VEHICLE MANUFACTURER FOR PROPER JACKING INSTRUCTIONS, SEE FIGURE 3-4

FIGURE 3-3

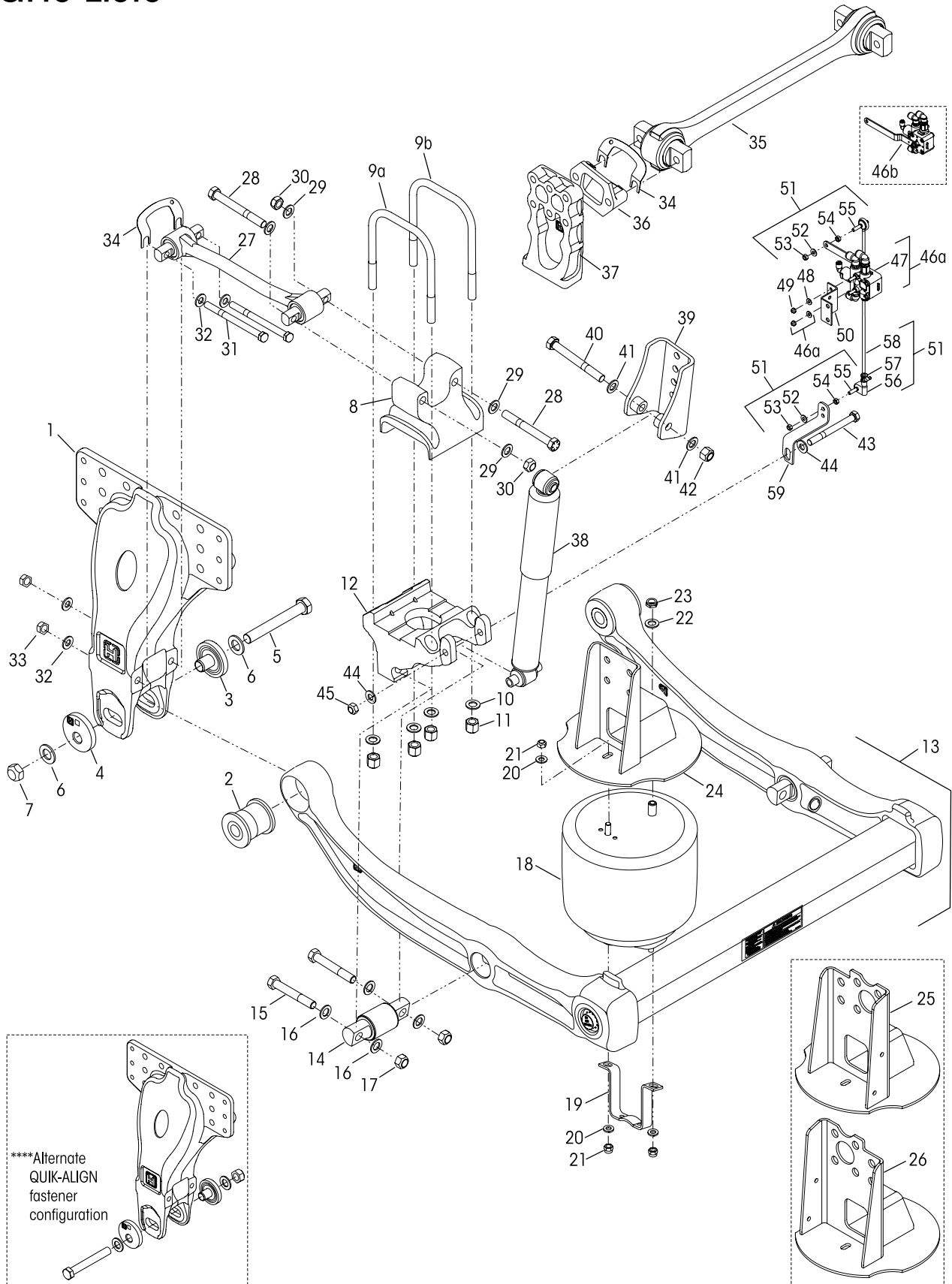

FIGURE 3-4





SECTION 4 Parts Lists





KEY NO.	PART NO.	DESCRIPTION	VEHICLE *QTY.
1	80735-001	Frame Hanger – CARC Tan 686A	6
		QUIK-ALIGN® Pivot Bushing Service Kit, Includes Keys Nos. 2-7, 60	
	60961-720	One Wheel End	
	60632-020	Axle Set	
		QUIK-ALIGN Collar Service Kit, Includes Keys Nos. 3-7	
	60632-019	One Wheel End	
	60632-021	Axle Set	
	60632-018	QUIK-ALIGN Fastener Service Kit, One Wheel End Includes Keys Nos. 5-7	
2	70425-001	QUIK-ALIGN Pivot Bushing	6
3	64633-000	QUIK-ALIGN Concentric Collar	6
4	64632-000	QUIK-ALIGN Eccentric Collar	6
5	68217-000	1"-14 UNF-2A x 7½" H-Coat Hex Bolt	6
6	68232-000	1" H-Coat Flat Washer	12
7	68218-000	1"-14 UNF-2B H-Coat Locknut	6
8	80731-001	Top Pad – CARC Tan 686A	6
		U-bolt Service Kit, Includes Key Nos. 9a-9b, 10-11	
	48718-120	One Wheel End	
	48718-117	Axle Set	
9		¾"-16 UNF-2A Square U-bolt	12
a	59367-007	10", Outboard	
b	59367-008	10½", Inboard	
10	22962-001	¾" Flat Washer	12
11	49685-000	¾"-16 UNF-2B U-bolt Locknut	12
12	80732-001	Bottom Cap – CARC Tan 686A	6
13	80863-001	U-Beam Assembly – CARC Tan 686A, Includes Key Nos. 2, 14	3
		D-pin Bushing Service Kits	
	34013-114	Single, Includes Key Nos. 14-17	
	56659-010	Fasteners Only, Axle Set, Includes Key Nos. 15-17	
14	65381-000	D-pin Bushing	6
15	30418-011	⅞"-14 UNF x 5" Bolt	12
16	22962-007	⅞" Flat Washer	24
17	29248-000	⅞"-14 UNF Locknut	12
18	67044-002	Air Spring	6
19	80734-001	Lower Air Spring Mounting Bracket CARC Tan 686A	6
		Air Spring Fastener Service Kit, Upper/Lower, Includes Key Nos. 20-23	
	49177-023	One Wheel End	
	49177-003	Axle Set	
20	22962-014	½" Flat Washer	18
21	17700-010	½"-13 UNC Locknut	18
22	22962-001	¾" Flat Washer	6
23	17700-031	¾"-16 UNF Locknut	6
24	80730-001	Front Upper Air Spring Bracket – CARC Tan 686A	4
		Rear Upper Air Spring Bracket – CARC Tan 686A	
25	91286-101	Left Hand	1
26	91286-201	Right Hand	1

KEY NO.	PART NO.	DESCRIPTION	VEHICLE *QTY.
27		***Longitudinal Torque Rod Assembly, <i>See Table 1 on Page 10</i>	
		Longitudinal Torque Rod Fastener Service Kits	
		• To Top Pad	
	49176-024	Axle Set, Includes Key Nos. 28-30	
	58821-021	One Wheel End, Includes Key Nos. 28-30	
		• To Frame Hanger	
	49176-032	Axle Set, Includes Key Nos. 31-33	
	58821-027	One Wheel End, Includes Key Nos. 31-33	
		• To Top Pad and Frame Hanger	
	49176-031	Axle Set, Includes Key Nos. 28-33	
28	21867-007	¾"-16 UNF x 6" Hex Bolt	12
29	22962-001	¾" Flat Washer	24
30	30191-000	¾"-16 UNF Locknut	12
31	32043-016	⅝"-11 UNC-2B x 8" Hex Bolt	12
32	22962-004	⅝" Flat Washer	24
33	47764-000	⅝"-11 UNC-2A Locknut	12
34	49689-000	Shim	As Req.
35	80738-001	***Transverse TRAAAX ROD™ – CARC Tan 686A	3
36	80746-001	Transverse Torque Rod Frame Bracket CARC Tan 686A	3
37	80742-001	Axle Stop, Frame Mounted – CARC Tan 686A	6
38	80733-001L	Shock Absorber – CARC Tan 686A	6
39	80743-001	Upper Shock Frame Bracket – CARC Tan 686A	6
	50754-064	Single Shock Absorber Fastener Service Kit Includes Key Nos. 40-45	
40	50764-018	¾"-10 UNC-2A x 6½" Hex Bolt	6
41	22962-001	¾" Flat Washer	12
42	49842-000	¾"-10 UNC-2B Locknut	6
43	32043-007	⅝"-1 UNC-2A x 7" Lower Shock Bolt	6
44	22962-004	⅝" Flat Washer	12
45	47764-000	⅝"-11 UNC-2B Locknut	6
46		Height Control Valve Assembly, Includes Key Nos. 47-49	2
	a	69031-004	Left Side Assembly (Drivers Side)
	b	69031-005	Right Side Assembly (Passenger Side)
47		**Height Control Valve	2
48		**¼" Flat Washer	4
49		**¼"-20 UNC Locknut	4
50	80748-001	HCV Mounting Bracket – CARC Tan 686A	
51	58994-062	HCV Linkage Assembly, Includes Key Nos. 52-58	2
52	22962-029	⅝" Flat Washer	4
53	59016-000	⅝"-18 UNC-2B Locknut	4
54	17491-011	⅝"-18 UNC-2B Nut	4
55	59169-000	⅝"-18 UNC Mounting Stud	4
56	58987-000	Valve Arm Joint	2
57	58969-000	Valve Arm Clamp	2
58	58993-010	HCV Extension Rod	2
59	80749-001	HCV Linkage Bracket – CARC Tan 686A	2
60	70867-001	P-80 Lubricant 10 ml (Not Shown) per Bushing	1

NOTES: * Quantities specified are for tridem suspension. Quantities of service kit components may vary from amount shown in lists.

** Item included in kit/assembly only, part not sold separately.

*** Longitudinal and transverse torque rod bushings are not serviceable, replacement requires complete torque rod assembly which includes bushings.

**** Alternate configuration of the QUIK-ALIGN fasteners shown in exploded view. The locknuts located inboard will allow additional clearance for wider tires or tires with chains. Tightening is still required ONLY on the locknut.



TABLE 1		Key No. 27	◆ CARC Tan 686A – Longitudinal Torque Rod Part Nos.	
Rear Axle Location	**Pinion Angle		Left Hand (Drivers Side)	Right Hand (Passenger Side)
Front	0°		80737-460A	80737-460B
Mid	2°		80737-475A	80737-475B
Rear	3°		80737-480A	80737-480B

◆ Longitudinal torque rod bushings are non-serviceable, replacement requires complete torque rod assembly which includes bushings.
 ** Measured with QUIK-ALIGN set at neutral position (12 O'Clock).

CROSS REFERENCE

HENDRICKSON PART NO.	MACK PART NO.	DESCRIPTION
17491-011	23490430	5/16"-18 UNC-2B Nut
17700-010	20760820	1/2"-13 UNC Locknut
17700-031	23490433	3/4"-16 UNF Locknut
21867-007	23490441	3/4"-16 UNF x 6" Hex Bolt
22962-001	25092158	3/4" Flat Washer
22962-004	25173404	3/4" Flat Washer
22962-007	23490435	7/8" Flat Washer
22962-014	23490436	1/2" Flat Washer
22962-028	23490437	1/4" Flat Washer
22962-029	23490438	5/16" Flat Washer
29248-000	85109234	7/8"-14 UNF Locknut
30191-000	23490440	3/4"-16 UNF Locknut
30418-011	23490443	7/8"-14 UNF x 5" Bolt
32043-007	23490444	3/4"-1 UNC-2A x 7" Lower Shock Bolt
32043-016	23490446	3/4"-11 UNC-2B x 8" Hex Bolt
47764-000	25157616	3/4"-11 UNC-2A Locknut
49685-000	20755348	3/4"-16 UNF-2B U-bolt Locknut
49689-000	24424092	Shim
49842-000	25153574	3/4"-10 UNC-2B Locknut
49983-000	23490445	1/4"-20 UNC Locknut
50764-018	23490447	3/4"-10 UNC-2A x 6 1/2" Hex Bolt
58969-000	23481879	Valve Arm Clamp
58987-000	23482698	Valve Arm Joint
58993-010	23482710	HCV Extension Rod
58994-062		HCV Linkage Assembly
59016-000	23490448	5/16"-18 UNC-2B Lock Nut
59169-000	23490449	5/16"-18 UNC Mounting Stud
59367-007	23490450	3/4"-16 UNF-2A Square U-bolt 10", Outboard
59367-008	23490451	3/4"-16 UNF-2A Square U-bolt 10 1/2", Inboard
60501-005	3975547	Height Control Valve
64632-000	20755337	QUIK-ALIGN Eccentric Collar
64633-000	20755339	QUIK-ALIGN Concentric Collar
65381-000		D-pin Bushing
67044-002	23482799	Air Spring
68217-000	21469179	1"-14 UNF-2A x 7 1/2" H-Coat Hex Bolt
68218-000	21469181	1"-14 UNF-2B H-Coat Locknut
68232-000	21469187	1" H-Coat Flat Washer
69031-004		Left Hand Height Control Valve Assembly (Drivers Side)
69031-005		Right Hand Height Control Valve Assembly (Passenger Side)
70425-001		QUIK-ALIGN Pivot Bushing
70867-001		P80 Lubricant 10 mL (Not Shown)
80730-001	23482857	Front Upper Air Spring Bracket CARC Tan 686A
80731-001		Top Pad CARC Tan 686A
80732-001	23482790	Bottom Cap CARC Tan 686A
80733-001	23482842	Shock Absorber CARC Tan 686A
80734-001	23482743	Lower Air Spring Mounting Bracket CARC Tan 686A



HENDRICKSON PART NO.	MACK PART NO.	DESCRIPTION
80735-001	23482860	Frame Hanger CARC Tan 686A
80737-460A		Left Hand Longitudinal Torque Rod CARC Tan 686A
80737-460B		Right Hand Longitudinal Torque Rod CARC Tan 686A
80737-475A		Left Hand Longitudinal Torque Rod CARC Tan 686A
80737-475B		Right Hand Longitudinal Torque Rod CARC Tan 686A
80737-480A		Left Hand Longitudinal Torque Rod CARC Tan 686A
80737-480B		Right Hand Longitudinal Torque Rod CARC Tan 686A
80738-001	23482870	Transverse TRAAX ROD Rod CARC Tan 686A
80742-001	23482868	Axle Stop, Frame Mounted CARC Tan 686A
80743-001	23482869	Upper Shock Frame Bracket CARC Tan 686A
80746-001	23482872	Transverse Torque Rod Frame Bracket CARC Tan 686A
80748-001	23481876	HCV Mounting Bracket CARC Tan 686A
80749-001	23482755	HCV Linkage Bracket CARC Tan 686A
80863-001	23482801	U-beam Assembly CARC Tan 686A
91286-101	23482858	Left Hand Rear Upper Air Spring Bracket CARC Tan 686A
91286-201	23482859	Right Hand Rear Upper Air Spring Bracket CARC Tan 686A

SECTION 5 Special Tools

D-PIN / QUIK-ALIGN PIVOT BUSHING SERVICE TOOLS

Hendrickson Part No. 66086-202

OTC Part No. 4246 Visit otctools.com

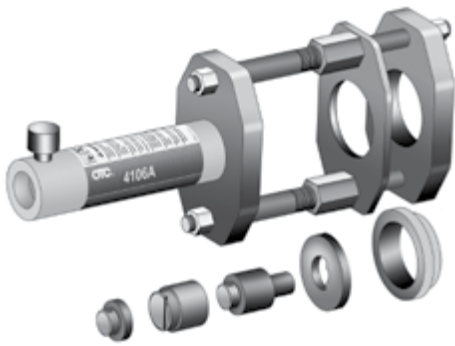

Hendrickson Part No. 66086-204

OTC Part No. 4247 Visit otctools.com

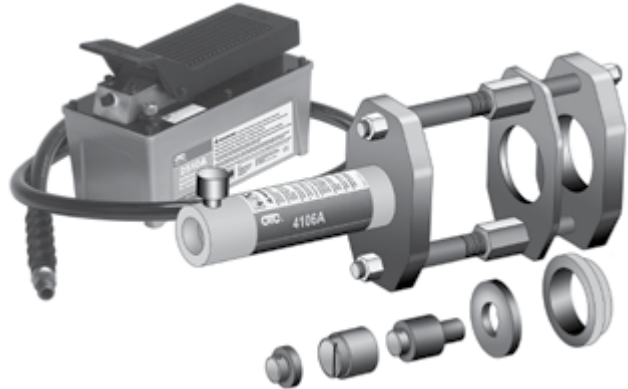

Hendrickson Part No. 66086-205

OTC Part No. 4254 Visit otctools.com

NOTE: In conjunction with Hendrickson Part No. 66086-204 (OTC 4247) this additional adapter tool kit is available to purchase to be used on Hendrickson SOFTEK NXT suspension (not needed for this suspension)

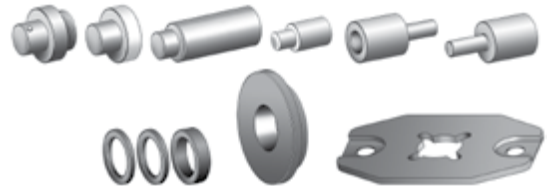

QUIK-ALIGN PIVOT BUSHING SERVICE TOOL

Hendrickson Part No. 66086-203L

Reference Literature No. 59310-061



QUIK-ALIGN SOCKET TOOL

Hendrickson Part No. 66086-200

OTC Part No. 1767

Visit otctools.com





SECTION 6 Preventive Maintenance

Following appropriate inspection procedures is important to help ensure the proper maintenance and operation of the suspension system and component parts function to their highest efficiency. Hendrickson recommends PRIMAAX EX heavy-duty rear suspensions be inspected at pre-delivery, the first 1,000 miles of service and at the regular preventive maintenance intervals. Off-highway and severe service operating conditions require more frequent inspections than on-highway service operation.

NOTE Torque values shown in this publication apply only if Hendrickson supplied fasteners are used. If non Hendrickson fasteners are used, follow the torque specification listed in the vehicle manufacturer's service manual.

AREAS OF INSPECTION

- Air springs
- Air supply and fittings
- All fasteners
- Clamp group:
Top pad • U-bolts and locknuts
- Frame hanger bracket
- Height control valve and air lines
- QUIK-ALIGN connections
- Shock absorbers
- Transverse TRAAX ROD
- Longitudinal torque rods
- Tire wear
- U-beam assembly: Cross tube / Support beam / End cap

■ Signifies performance critical components.

HENDRICKSON RECOMMENDED INSPECTION INTERVALS

	PRE-DELIVERY INSPECTION	FIRST IN-SERVICE INSPECTION	PREVENTIVE MAINTENANCE
Visual inspection for proper assembly and function. Check for all of the following and replace components as necessary:			Off-highway Every 6 Months/1,200 Hours or 25,000 miles/ 40,000 km, whichever comes first On-Highway Every 12 Months or 50,000 miles, whichever comes first
<ul style="list-style-type: none"> • Signs of unusual movement, loose or missing components • Signs of abrasive or adverse contact with other components • Damaged, or cracked parts • Improper suspension function or alignment 			
Visually inspect the overall condition of and for any signs of damage to:			Every 12 Months / 2400 Hours
<ul style="list-style-type: none"> • U-beam assembly • Air springs and air lines 	Within the first 500 miles (500 km)	Within the first 1,000 miles (1,600 km) or 100 Hours	
Inspect fasteners for proper torque as recommended in the Torque Specification Section of this publication:			
<ul style="list-style-type: none"> • QUIK-ALIGN fasteners and torque rod to top pad fasteners, see Figure 6-1 • Clamp group U-bolt fasteners, see Figure 6-1 • DO NOT re-torque Integrated End Cap, see Figure 6-2 • Transverse TRAAX ROD fasteners, see vehicle manufacturer's specifications 			
Verify the lateral alignment of the drive axles are within the vehicle manufacturer's tolerances			
Verify the ride height. Refer to ride height in the Alignment & Adjustment section of this publication			

See vehicle manufacturer's applicable publications for other preventive maintenance requirements.

NOTE

Figures 6-1 and 6-2 illustrate PRIMAAX EX suspension basic connections.

FIGURE 6-1

15½" Ride Height

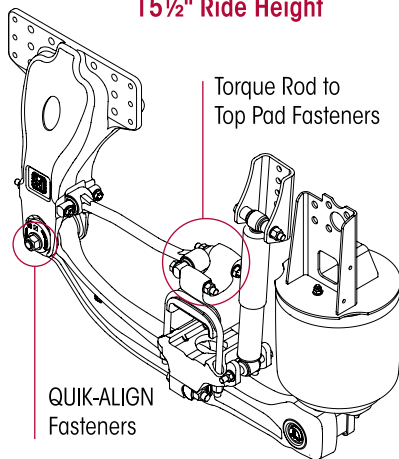

Clamp Group Fasteners

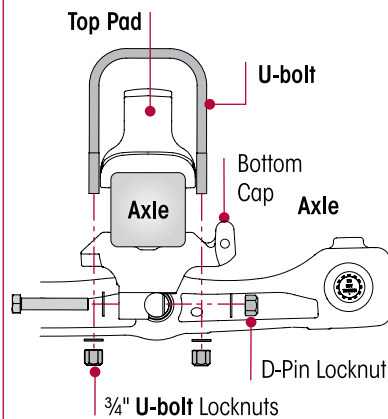
FIGURE 6-2
Integrated End Cap

PRIMAAX EX

DO NOT re-torque the integrated end cap.

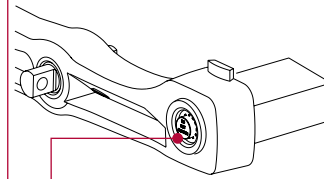

INTEGRATED End Cap

DO NOT re-torque. **Tamper Resistant Cap** attached to integrated end cap bolts with SIKAFLEX 221 sealant applied around the cap.

COMPONENT INSPECTION

IMPORTANT NOTE

Replace all worn or damaged parts.

- **Air springs** — Visually inspect the outer surface of the air spring for chafing, uneven wear, cracks or any signs of component damage. Ensure that the upper bead plate is tight against the underside of the frame. Check for any lateral slippage at the lower air spring bracket. An 1/8" of slippage in either direction is acceptable. Verify all mounting hardware have the proper torque values maintained. See the Torque Specification Section of this publication for recommended torque requirements.
- **Air supply (Pneumatic components)** — The air supply to the system plays a large role in the air springs' performance. Inspect, clean and replace, if necessary, any support products to the air springs, valves, regulators and air lines. See Air Fitting Inspection in this section if an air leak is suspected.
- **Clamp group** — Visually inspect for any loose or damaged fasteners. Verify the U-bolt locknuts have the proper torque values maintained. See the U-bolt Locknuts in this section.
- **Fasteners** — Visually inspect for any loose or damaged fasteners on the entire suspension. Make sure all fasteners are tightened to a torque value within the specified torque range. See Torque Specification Section in this publication for recommended torque requirements. Use a calibrated torque wrench to check torque in a tightening direction. As soon as the fastener starts to move, record the torque and correct the torque if necessary.
- **Frame hanger bracket** — Visually inspect for any signs of loose fasteners, movement, or damage. Verify the frame attaching fasteners have the proper torque values maintained. See the vehicle manufacturer for proper torque specifications.
- **Height control valve and Air lines** — Check the suspension air system for air leaks. Check all air lines for proper routing. Check for chafing or pinched air lines. Check the height control valve linkage for damage or interference with peripheral components.
- **QUIK-ALIGN connection** — Visually inspect the connection for signs of looseness or movement. Visually inspect the bushing for wear. Verify the connections have the proper torque values maintained. See the Torque Specification Section of this publication for recommended torque requirements. See QUIK-ALIGN Fastener Warnings in the Important Safety Notice Section of this publication prior to installing the QUIK-ALIGN connection.
- **Shock absorbers** — Visually inspect for any signs of dents or leakage. Misting is not considered a leak, see Shock Absorber Inspection in this section.

- **Tire wear** — Visually inspect the tires for wear patterns that may indicate suspension damage or misalignment.
- **Top pad/Longitudinal torque rod connection** — Visually inspect the connection for signs of movement or damage. Use a lever check to help assess movement in this joint, see Longitudinal and Transverse Torque Rods in this section for proper inspection. Verify the top pad/longitudinal torque rod connections have the proper torque values maintained. See the Torque Specifications Section of this publication for recommended torque requirements.
- **Torque rods (longitudinal and transverse)** — All torque rods must be inspected for looseness, torn or shredded rubber, and for proper fastener torque. If there is metal-to-metal contact in the bushing joint, this is a sign of excessive bushing wear and the torque rod needs to be serviced, see Longitudinal and Transverse Torque Rod inspection in this section.

NOTE

Torque rods assemblies equipped on the PRIMAAX EX suspension for Mack HDT vehicles have curled end hubs and are not re-bushable. The entire torque rod assembly must be replaced. This feature provides superior bushing retention in the torque rod end hub.

- **U-beam assembly**— Visually inspect for cracks, damage, metal shavings, or looseness at the U-beam connection. Visually inspect the overall condition of the support beam for dents, dings, or other damage on the outer edges of the beam flanges. Visually inspect the D-pin bushings for tearing or extreme bulging. Check for any metal-to-metal contact in the bushed joints.
- **Wear and damage** — Visually inspect all parts of the suspension for wear and damage. Look for bent or cracked parts.

See vehicle manufacturer’s applicable publications for other preventive maintenance requirements.

U-BOLT LOCKNUTS

NOTE

U-bolt clamp group hardware for the PRIMAAX EX suspension is ¾"-16 UNF Grade C locknuts and ¾"-16 UNF Grade 8 U-bolts which are phosphate and oil coated.

1. U-bolt locknuts (see Figure 6-3) must be torqued to specification at preparation for delivery.
2. U-bolt locknuts must be re-torqued at 1,000 miles.
3. Thereafter, follow the inspection and re-torque intervals below:
 - **Off-highway and severe service** – Every 25,000 miles or 6 months, whichever comes first.
 - **100% On-highway** – Every 50,000 miles or 12 months, whichever comes first.

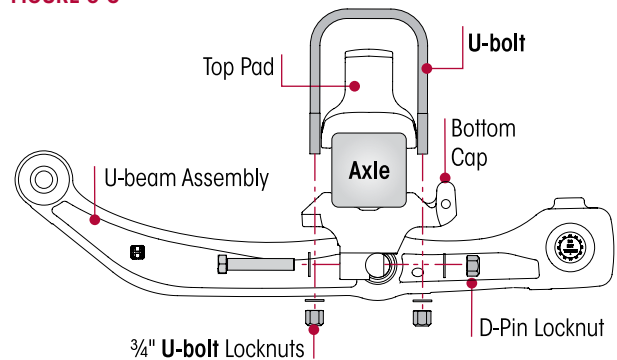
FIGURE 6-3

Off-highway and severe service operating conditions require more frequent inspections than on-highway service operation.

SERVICE HINT

Due to certain pinion angle configurations, the removal of the D-Pin bolts may be necessary to access the U-bolt locknuts.

WARNING

IT IS IMPORTANT THAT THE U-BOLT CLAMP GROUP CONNECTION BE PROPERLY ALIGNED AND HAVE THE PROPER TORQUE VALUES MAINTAINED. METAL SURFACES CAN WORK AND WEAR AGAINST OTHER RELATED CLAMP GROUP COMPONENTS IF NOT PROPERLY ALIGNED OR PROPERLY TIGHTENED TO MAINTAIN THE PROPER CLAMP FORCE. FAILURE TO DO SO CAN CAUSE PREMATURE COMPONENT WEAR, POSSIBLE SEPARATION OF THE CLAMP GROUP, CAUSING ADVERSE VEHICLE HANDLING, PROPERTY DAMAGE, OR PERSONAL INJURY.

- Tighten the U-bolt locknuts evenly in 50 foot pound increments to 375 ± 25 foot pounds torque in the proper pattern to achieve uniform bolt tension, see Figures 6-4.

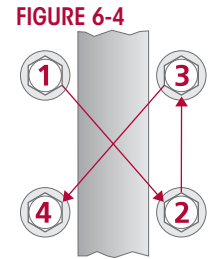

PIVOT BUSHING AND D-PIN BUSHING INSPECTION

WARNING

THE PIVOT BUSHING AND THE D-PIN BUSHING ARE CRITICAL COMPONENTS OF THE PRIMAAX EX SUSPENSIONS. IF ANY SUCH COMPONENTS APPEAR DAMAGED OR WORN THE COMPONENT MUST BE REPLACED. FAILURE TO REPLACE SUCH WORN OR DAMAGED COMPONENTS CAN RESULT IN THE DEFORMATION OF PARTS, LOSS OF CLAMP FORCE, BOLT FAILURE, LOSS OF THE AXLE'S ALIGNMENT, ADVERSE VEHICLE HANDLING, PROPERTY DAMAGE, OR PERSONAL INJURY.

There are two types of pivot bushing inspections for the PRIMAAX EX suspension. The pivot bushing can be visually inspected by looking at the outer rubber flange(s) of the bushing. If the visual inspection warrants, a physical inspection can be conducted in which disassembly is required.

PIVOT BUSHING VISUAL INSPECTION

To perform pivot bushing visual inspection, it is not necessary to disassemble the pivot bushing connection. If the pivot bushing rubber flange(s) are intact and there are no signs of metal to metal contact the bushing does not require replacement.

- The support beam is designed with the pivot bushing centered in the support beam end hub. If the pivot bushing is not centered in the end hub, it is an indication that the pivot bushing could be worn and a pivot bushing physical inspection is required.
- If the pivot bushing shows signs of torn, separated or disconnected rubber, see Figures 6-5 and 6-6, this could be a result of axle misalignment. If this condition is evident, a pivot bushing physical inspection is required.
- If the outer rubber flange(s) is missing, or there are shards of rubber visible, see Figure 6-7, this could be a result of axle misalignment. If this condition is evident, pivot bushing replacement is required.

FIGURE 6-5

FIGURE 6-6

FIGURE 6-7

INSPECT FOR TORN, DISCONNECTED OR MISSING RUBBER FLANGE

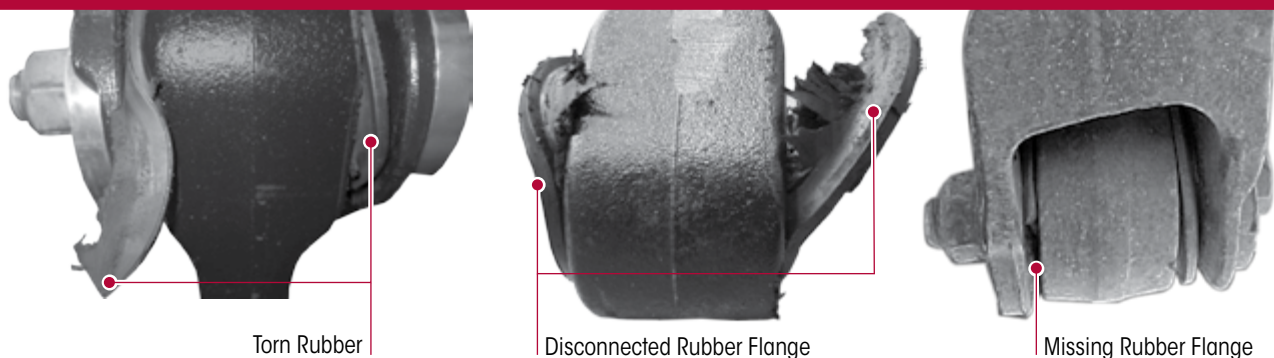

Torn Rubber

Disconnected Rubber Flange

Missing Rubber Flange

PIVOT BUSHING PHYSICAL INSPECTION

- Remove the U-beam assembly, refer to U-beam Assembly in the Component Replacement of this publication.
- After removal, inspect the pivot bushing connection, examine the pivot bushing inner metal area.

3. No replacement is needed if the bushing exhibits a tight joint, see Figure 6-8. An imprinted two-line wear pattern on the bushing inner metal indicates the pivot bushing is securely clamped in the frame hanger.
4. Inspect pivot bushing, replacement is necessary if any indications of the following are apparent, see Figure 6-9:
 - Signs of rust, distorted, separated or torn rubber, elongated or damaged bore. This could be a result of axle misalignment or loose fasteners.

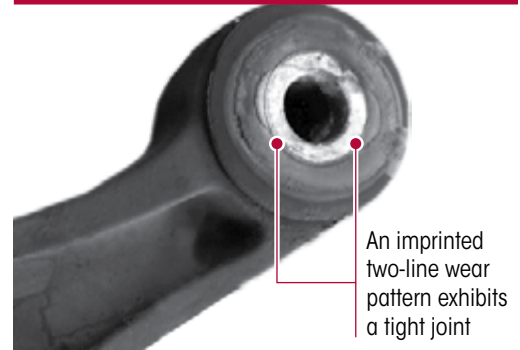
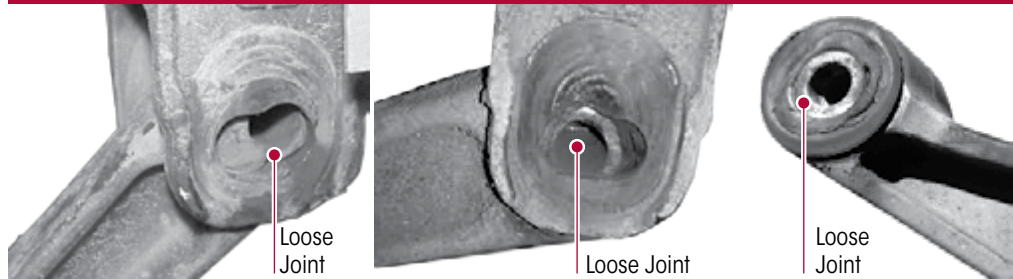
FIGURE 6-8
GOOD JOINT - NO REPLACEMENT NEEDED

FIGURE 6-9
INSPECT FOR INDICATIONS OF A LOOSE JOINT

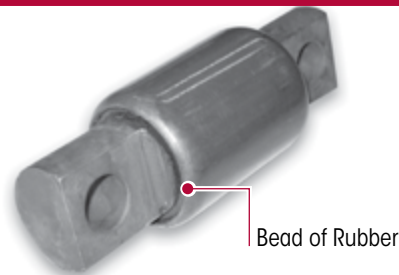
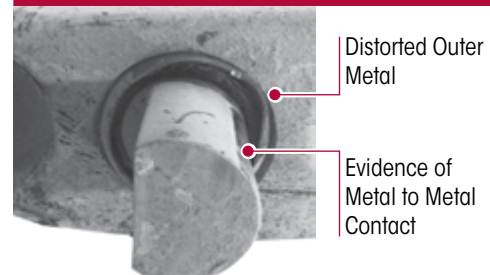
5. Inspect the inside of the frame hanger legs and the QUIK-ALIGN collars. If any of the following are present, the pivot bushing and one (1) or more of the mating components may require replacement:
 - Evidence of wear marks on the inside of the frame hanger legs indicating metal to metal contact or movement
 - The snout of the QUIK-ALIGN concentric or eccentric collar is elongated or damaged
6. Check the suspension alignment and adjust if necessary. Refer to Alignment & Adjustments Section of this publication.

D-PIN BUSHING VISUAL INSPECTION
FIGURE 6-10
ACCEPTABLE D-PIN

FIGURE 6-11
UNACCEPTABLE D-PIN

It is not necessary to disassemble the D-Pin connection to perform a D-Pin visual inspection. The D-Pin bushing is designed with a layer of rubber in the bushing, it is acceptable to see a bead of rubber protruding from the bushing, see Figure 6-10.

D-Pin bushing replacement **IS REQUIRED** only when:

- Metal to metal contact wear marks on the D-pin outer metal are evident, see Figure 6-11
- D-pin outer metal is distorted, see Figure 6-11

WARNING

LONGITUDINAL AND TRANSVERSE TORQUE RODS

THE PRIMAAX EX SUSPENSION INCORPORATES TRANSVERSE TRAAX RODS FOR VEHICLE STABILITY. IF THESE COMPONENTS ARE DISCONNECTED OR ARE NON-FUNCTIONAL THE VEHICLE SHOULD NOT BE OPERATED. FAILURE TO DO SO CAN RESULT IN ADVERSE VEHICLE HANDLING, POSSIBLE TIRE CONTACT WITH THE FRAME, SEVERE PERSONAL INJURY, AND PREMATURE COMPONENT DAMAGE.

VISUAL INSPECTION

All torque rods need to be inspected during preventive maintenance and service for looseness.

Visually inspect (1) torque rod bushings for any torn or shredded rubber material interfaces or elongated oval shapes and **(2) torque rods** for any metal to metal contact, bent, cracked or broken components. The torque rod will require replacement if any of these conditions are encountered.

Torque rod looseness inspection is necessary. With the vehicle shut down, a lever check can be made with a long pry bar placed under each torque rod end and pressure applied.

Torque rod length is determined by the original vehicle manufacturer, see Figure 6-12.

The transverse torque rods also control axle walk-out during cornering. The mounting bracket at the axle housing end of the torque rods are furnished and welded into position on the axle housings by the axle or vehicle manufacturer, see Figure 6-12.

If the lateral alignment of the axles is incorrect, it may be necessary to add the shim to transverse torque rod, see Figure 6-12. Refer to Lateral Alignment in the Alignment & Adjustments Section of this publication.

NOTE

Hendrickson Suspension recommends Grade 8 bolts, hardened flat washer and Grade C locknuts be used for all straddle mount torque rod attachments.

It is important that the **tightening torque** of the locknuts be checked during preventive maintenance and service. Follow the tightening torque specifications and all applicable preventive maintenance, service and safety instructions issued by the respective vehicle and suspension manufacturers.

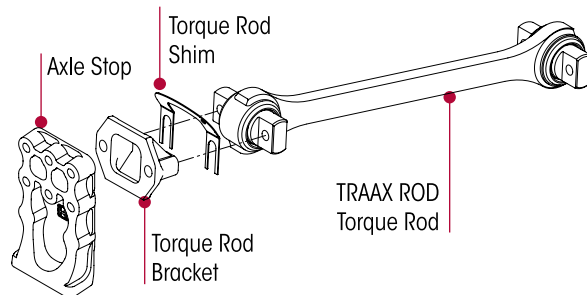
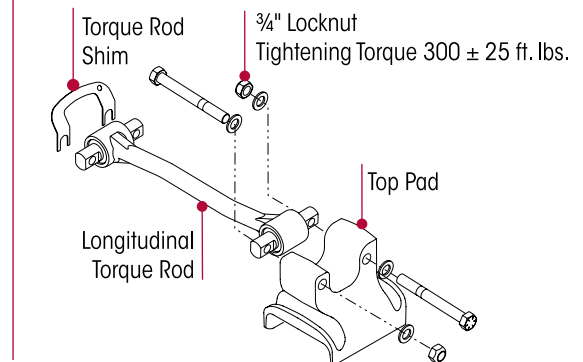
FIGURE 6-12
Transverse Torque Rod

Longitudinal Torque Rod

AIR FITTING INSPECTION

1. If an air leak is suspected, begin by building up the air system to normal operating pressure.
2. Spray all nylon tube air fittings with a soapy water solution to detect the leak location.

NOTE

Air lines and fittings may be inspected for leaks using a soapy water solution. The height control valve, however, cannot be inspected using this method. All height control valves have an allowable leakage rate. The only acceptable method for inspection of the height control valves is the height control valve test found in this section.

3. If an air leak is located, ensure the tubing end is clean and in good condition and the end is cut square. Check to see if the tubing is binding, bent or being pulled upon.
4. Visually inspect the air fitting's O-ring seal for signs of damage or contamination.



SHOCK ABSORBER INSPECTION

NOTE

It is not necessary to replace shock absorbers in pairs if only one (1) shock absorber requires replacement.

Hendrickson uses a long service life, premium shock absorber on all PRIMAAX EX suspensions. When the shock absorber replacement is necessary, Hendrickson recommends that the shock absorbers be replaced with identical Hendrickson Genuine parts for servicing. Failure to do so will affect the suspension performance, durability, and will void any applicable warranty. See vehicle manufacturer's applicable publications for other shock absorber inspection requirements.

Inspection of the shock absorber can be performed by doing a heat test, and a visual inspection. Replace as necessary, refer to the Component Replacement Section of this publication.

FIGURE 6-13



HEAT TEST INSPECTION

1. Drive the vehicle at moderate speeds on rough road for minimum of fifteen minutes.



WARNING

DO NOT GRAB THE SHOCK ABSORBER AS IT COULD POSSIBLY BE HOT AND CAUSE PERSONAL INJURY.

2. Use an infrared thermometer to check the temperature of the shock absorber. This can also be performed by carefully touching the shock absorber body below the dust cover. Touch the frame to get an ambient reference, see Figure 6-13. A warm shock absorber is acceptable, a cold shock absorber should be replaced.
3. To inspect for an internal failure, remove and shake the suspected shock absorber. Listen for the sound of metal parts rattling inside. Rattling of metal parts can indicate that the shock absorber has an internal failure and the shock absorber should be replaced.

VISUAL INSPECTION

Look for these potential problems when doing a visual inspection. Inspect the shock absorbers fully extended. Replace as necessary.

FIGURE 6-14

SHOCK ABSORBER VISUAL INSPECTION - UNACCEPTABLE CONDITIONS



LEAKING VS. MISTING SHOCK ABSORBER VISUAL INSPECTION

The inspection must not be conducted after driving in wet weather or a vehicle wash. The shock absorber needs to be free from water. Many shock absorbers are often misdiagnosed as failures. Misting is the process whereby very small amounts of shock absorber fluid evaporate at a high operating temperature through the upper seal of the shock absorber. When the "mist" reaches the cooler outside air, it condenses and forms a film on the outside of the shock absorber body. Misting is perfectly normal and necessary function of the shock absorber. The fluid which evaporates through the seal area helps to lubricate and prolong the life of the seal.

NOTE

PRIMAAX EX systems are equipped with a premium seal on the shock absorber, however this seal will allow for misting to appear on the shock absorber body (misting is not a leak and is considered acceptable).

Inspect the shock absorber fully extended. **A shock absorber that is truly leaking** will show signs of fluid **leaking in streams from the upper seal**. These streams can easily be seen, underneath the main body (dust cover) of the shock absorber. Replace as necessary.

FIGURE 6-15

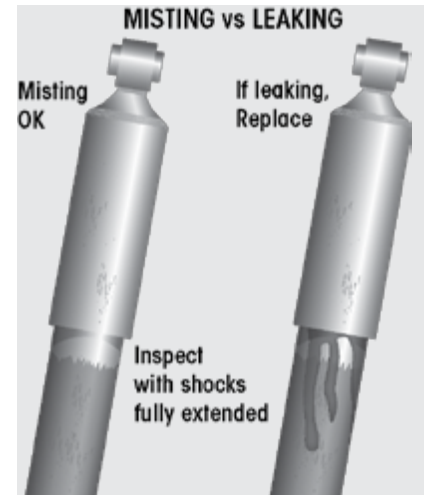

SECTION 7

Alignment & Adjustments

RIDE HEIGHT – Dual Height Control Valves

Hendrickson requires dual height control valves (see Figure 7-1) for Mack HDT vehicles equipped with PRIMAAX EX tridem suspension.

FIGURE 7-1



INSPECTION

SERVICE HINT

When inspecting or setting ride height on a lightly loaded vehicle, such as, a bobtail tractor equipped with dual height control valves, it is necessary to have a load on the vehicle. Loading the vehicle to its normal operating condition, such as a tractor with a loaded trailer, increases ride height setting accuracy.

1. Drive the vehicle onto a level surface.
2. Free and center all suspension joints by slowly moving vehicle back and forth several times without using the brakes. **When coming to a complete stop, make sure the brakes are released.** End with all wheels positioned straight ahead. Try to roll to a stop without the brakes being used. **DO NOT** set the parking brake.
3. Chock front wheels of the vehicle.
4. When checking or adjusting ride height, verify and maintain the vehicle's air system at full operating pressure.

SERVICE HINT

It is very important that the height control valves be cycled completely before and after any ride height adjustments. The cycling of the height control valve will help to make the adjustment more accurate.

WARNING

PRIOR TO AND DURING DEFLATION AND INFLATION OF THE AIR SUSPENSION SYSTEM, ENSURE THAT ALL PERSONNEL AND EQUIPMENT ARE CLEAR FROM UNDER THE VEHICLE AND AROUND THE SERVICE AREA, FAILURE TO DO SO CAN CAUSE SERIOUS PERSONAL INJURY, DEATH, OR PROPERTY DAMAGE.

5. See additional Air Spring Cautions and Warnings in the Important Safety Notice Section of this publication prior to deflating or inflating the air system.

WARNING

SOME VEHICLE APPLICATIONS, SUCH AS VEHICLES EQUIPPED WITH OUTRIGGERS, RETAIN SOME AIR PRESSURE IN THE AIR SPRINGS AT ALL TIMES. PRIOR TO PERFORMING ANY MAINTENANCE, SERVICE, OR REPAIR OF THE SUSPENSION, VERIFY EACH AIR SPRING IS COMPLETELY DEFLATED. FAILURE TO DO SO COULD RESULT SERIOUS PROPERTY DAMAGE AND/OR SEVERE PERSONAL INJURY.

FIGURE 7-2

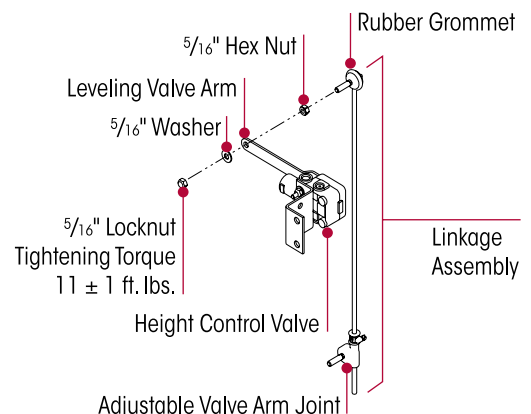

6. Deflate the suspension by using one of the following appropriate methods:
 - a. If vehicle is equipped with a suspension dump system in the cab, deflate the suspension air system by using the cab dump valve control.
 - b. If not equipped with a suspension dump system, detach both the upper rubber grommets of the height control valve linkages from the height control valve arms and exhaust the suspension system air by lowering the height control valve arms, see Figure 7-2.

7. Inflate the suspension by using one of the following methods:
 - a. If the vehicle is equipped with a suspension dump system in the cab, inflate the suspension air system by using the cab dump valve control. Allow the suspension system to inflate.
 - b. If the vehicle is not equipped with a suspension dump system, raise the height control valve arms and attach the upper rubber grommets of the height control valve linkage to the height control valve arms. Allow the suspension system to inflate.
8. Measure the suspension ride height. Measure the distance from the bottom of the frame rail to the axle centerline on the wheel ends where the height control valves are located.

NOTE A vehicle equipped with dual height control valves must measure the ride height at each height control valve location.

NOTE All ride heights are measured on the axle attached to the height control valve(s). Ride height is measured from the bottom of the frame to the axle centerline.

9. Compare the measured ride height dimensions to the specified dimension for your suspension in Figure 7-3.
 - a. If ride height **IS** $15\frac{1}{2}'' \pm \frac{1}{8}''$ then height control valve adjustment is not required.
 - b. If ride height is **NOT** $15\frac{1}{2}'' \pm \frac{1}{8}''$ then height control valve adjustment is required. Refer to the Adjustment Procedure in this section.

FIGURE 7-3

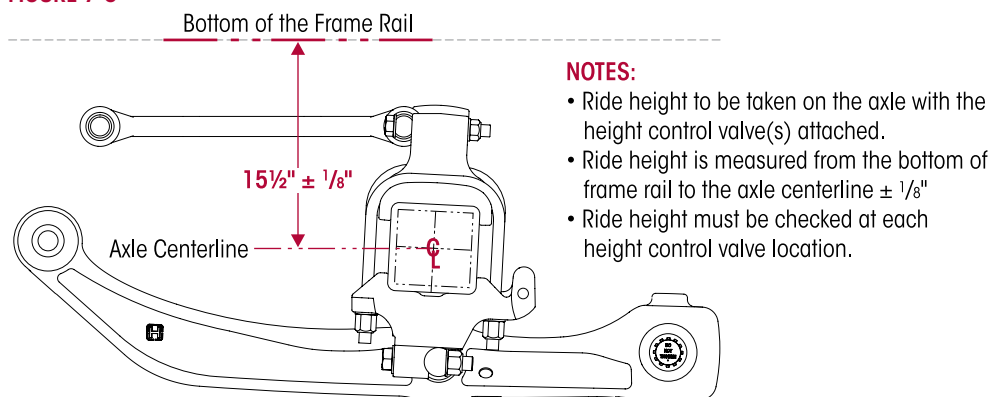

ADJUSTMENT PROCEDURE

SERVICE HINT When inspecting or setting ride height on a lightly loaded vehicle, such as a bobtail tractor, equipped with dual height control valves, it is necessary to have a load on the vehicle. Loading the vehicle to its normal operating condition, such as a tractor with a loaded trailer, increases ride height setting accuracy.

1. Drive the vehicle onto a level surface.
2. Free and center all suspension joints by slowly moving vehicle back and forth several times without using the brakes. When coming to a complete stop, make sure the brakes are released. End with all wheels positioned straight ahead. Try to roll to a stop without the brakes being used. **DO NOT** set the parking brake.
3. Chock front wheels of the vehicle.
4. When checking or adjusting ride height, verify and maintain the vehicle's air system at full operating pressure.

SERVICE HINT It is very important that the height control valves be cycled completely before and after any ride height adjustments. The cycling of the height control valves will help to make the adjustment more accurate.



WARNING PRIOR TO AND DURING DEFLATION AND INFLATION OF THE AIR SUSPENSION SYSTEM, ENSURE THAT ALL PERSONNEL AND EQUIPMENT ARE CLEAR FROM UNDER THE VEHICLE AND AROUND THE SERVICE AREA, FAILURE TO DO SO CAN CAUSE SERIOUS PERSONAL INJURY, DEATH, OR PROPERTY DAMAGE.

- See additional Air Spring Cautions and Warnings in the Important Safety Notice Section of this publication prior to deflating or inflating the air system.

WARNING

SOME VEHICLE APPLICATIONS, SUCH AS VEHICLES EQUIPPED WITH OUTRIGGERS, RETAIN SOME AIR PRESSURE IN THE AIR SPRINGS AT ALL TIMES. PRIOR TO PERFORMING ANY MAINTENANCE, SERVICE, OR REPAIR OF THE SUSPENSION, VERIFY EACH AIR SPRING IS COMPLETELY DEFLATED. FAILURE TO DO SO COULD RESULT SERIOUS PROPERTY DAMAGE AND/OR SEVERE PERSONAL INJURY.

- Detach the upper rubber grommets of the height control valve linkages from the height control valve arms and exhaust the suspension system air by lowering the height control valve arms.
- Refill the suspension by raising the height control valve arms by hand, so that the air springs are above the proper ride height.
- Lower the height control valve arms to exhaust the suspension air system until the suspension is at proper ride height.

NOTE

Adjustments to one (1) height control valve may affect ride height setting on the other height control valve. Verify ride height is correct at both height control valves whenever an adjustment is made.

- Use a 1/8" wooden dowel rod (golf tee) to set the neutral position for each height control valve by aligning the hole in the leveling arm with the hole in the height control valve cover, as shown in Figure 7-4. **DO NOT** use a metal rod or nail as this may cause damage to the height control valve.

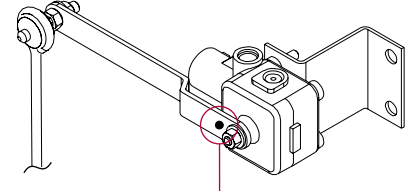
FIGURE 7-4

To set neutral position align hole with hole on height control valve cover

- Steps 7 to 9 might need to be repeated using one (1) height control valve at a time.
- Correct the adjustable valve arm joints so the rubber grommets can be reconnected to the height control valve arms at the proper height. Check the rubber components for any tearing or damage, replace as necessary.
- Connect the rubber grommets to the height control valve arms.
- Tighten the clamps on the adjustable valve arm joints with a screwdriver until securely fastened, see Figure 7-2. Remove the dowel from the height control valves.
- Verify the ride height is correct by performing the Ride Height Inspection as detailed in this section.

DRIVE AXLE ALIGNMENT INSPECTION

Proper alignment is essential for maximum ride quality, performance, and tire service life, the recommended alignment procedure is described below. This procedure should be performed if excessive or irregular tire wear is observed, or any time the QUIK-ALIGN connection is loosened or removed.

- Use a work bay with a level surface.
- Relax the suspension by slowly moving the vehicle back and forth several times in a straight line without using the brakes. This will slacken or loosen the suspension as the vehicle is positioned. End with all wheels positioned straight ahead.
- DO NOT** set the parking brake. Chock the front wheels of the vehicle.
- Verify and maintain the air system at full operating pressure.
- Verify the vehicle is at the correct ride height. Correct as necessary. Refer to Ride Height Adjustment in this section.
- Verify all suspension components are in good condition. Repair or replace any worn or damaged suspension components before proceeding with the alignment process.
- Ensure all drive axle tires are the same size.

FIGURE 7-5

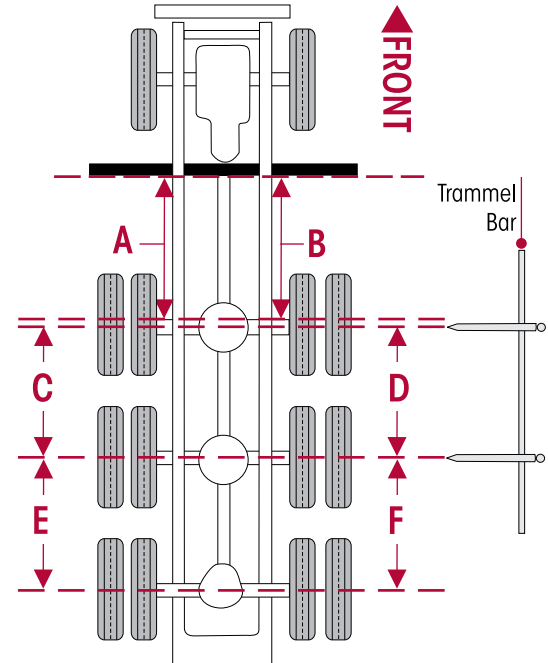

8. If axle alignment equipment is not available, using "C" clamps, securely clamp a six-foot piece of STRAIGHT bar stock or angle iron across the lower frame flange as shown in Figure 7-5. Select a location for the angle iron as far forward of the drive axle as possible where components will not interfere.
9. Accurately square the straight edge to the frame using a carpenter's square.
10. Using a measuring tape, measure from the straight edge to the forward face of the front drive axle arms at the center-line on both sides of the vehicle as shown in Figure 7-5, **A** and **B**.
11. Calculate the difference between measurements **A** and **B**.
 - a. If the front drive axle is within vehicle manufacturer's specifications, proceed to check the rear drive axle (Step 12).
 - b. If alignment of the front drive axle **IS NOT** within the vehicle manufacturer's specifications, then the alignment of this axle **MUST** be corrected **BEFORE** measuring the rear drive axle alignment (Step 12). Correct the alignment of this axle by following the proper alignment instructions for the PRIMAAX EX suspension model as determined by the ride height of the suspension.

NOTE

Since the remaining drive axle(s) will be aligned relative to the front drive axle, it is essential that the front drive axle is aligned within the vehicle manufacturer's specifications prior to the alignment of the remaining drive axle(s).

12. Using a trammel bar, measure the distance from the spindle center of the front drive axle to the spindle center of the rear drive axle on both sides of the vehicle, see Figure 7-5, **C** and **D**.
13. Calculate the difference between measurements **C** and **D**.
 - a. If the measurements are within the vehicle manufacturer's specifications, then the rear drive axle alignment is acceptable. Proceed to check the pinion angles of the drive axles (Step 15).
 - b. If alignment of the rear drive axle **IS NOT** within the vehicle manufacturer's specifications, then the alignment of this axle **MUST** be corrected **BEFORE** checking the drive axle pinion angles. Correct the alignment of this axle by following the proper alignment instructions for the PRIMAAX EX suspension model as determined by the ride height of the suspension.
14. Repeat Steps 12 and 13 for any remaining drive axle(s). Be sure all remaining drive axles are aligned relative to the front drive axle.
15. After all drive axles are aligned, check the pinion angle of each drive axle with a digital protractor, see Figure 7-6. Refer to the vehicle manufacturer specifications for the required pinion angles.
 - a. If all pinion angles are within the vehicle manufacturer's specifications then proceed to Step 16.
 - b. If any pinion angle is out of the vehicle manufacturer's specifications it must be corrected. Follow the Axle Pinion Angle adjustment procedure.
16. Recheck measurements to confirm adjustments. Repeat Steps 10 through 15 until the correct alignment and pinion angles are achieved.
17. When all drive axle alignments and pinion angles are within the vehicle manufacturer's specifications then the alignment procedure is complete.

AXLE PINION ANGLE

Drive axle pinion angles are established by the vehicle manufacturer. The bottom caps are machined to specific angles to meet the vehicle manufacturer's specified requirements, see Table 1 in the Parts Lists Section of this publication. If it is necessary to fine tune the pinion angle see the Alignment & Adjustments Section of this publication.

To check the pinion angle, verify first that the suspension is at the proper ride height (see Ride Height Adjustment in this Section), place a digital protractor on the axle housing as shown in Figure 7-6. Verify the pinion angle is within the range specified by the vehicle manufacturer.

FIGURE 7-6



AXLE LATERAL ALIGNMENT

FIGURE 7-7

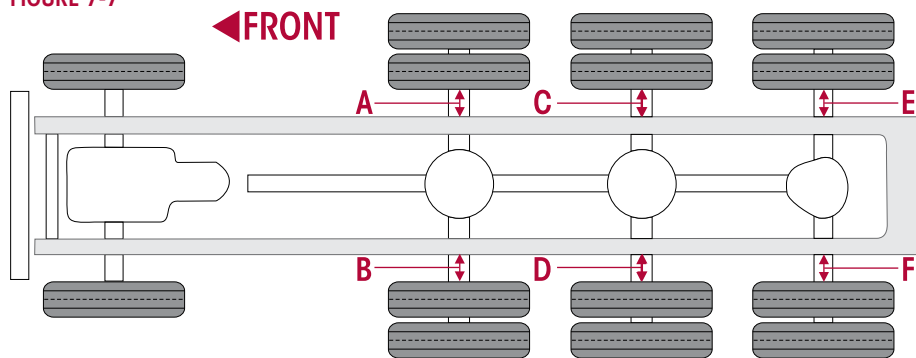

1. Use a work bay with a level floor. Drive the vehicle slowly, straight ahead. Try to slacken or loosen the suspension as the vehicle is positioned. End with all wheels positioned straight ahead. Try to roll to a stop without the brakes being used. **DO NOT** set the parking brake. Chock the front wheels of the vehicle.
2. Measure from the outside of the frame rail to the rim flange of the inner tire. Record the measurement **A** and **B**, see Figure 7-7.
3. Measure the same distance on remaining axle(s). Record the measurements **C**, **D** and **E**, **F**, see Figure 7-7.
4. Verify the axle lateral alignment is within the vehicle manufacturer's specifications. Adding or removing shims that are located between the transverse torque rod and the frame rail will normally correct the axle lateral alignment.
 - A general rule of thumb is to use a torque rod shim with a thickness that is half of the difference between the two measurements.

EXAMPLE

If the axle lateral alignment is out of specification by $\frac{1}{4}$ " (6 mm), remove or install a $\frac{1}{8}$ " (3 mm) torque rod shim between the transverse torque rod and frame rail as needed. Refer to Longitudinal and Transverse Torque Rod Section in Preventive Maintenance Section of this publication.

NOTE

Hendrickson recommends the use of Grade 8 bolts and Grade C locknuts. Washers are not necessary when flanged fasteners are used.



ALIGNMENT ADJUSTMENT INSTRUCTIONS

SERVICE HINT

The eccentric collars (with the square drive feature) are located on the outboard side of the frame hangers with the concentric collars on the inboard side. The total range of fore/aft axle adjustment is 1.0" ± ½".

SERVICE HINT

A suspension equipped with eccentric QUIK-ALIGN collars on both sides of an axle can be adjusted on both sides. A suspension equipped with an eccentric QUIK-ALIGN collar on only one side of the axle can be adjusted only on the side that has the eccentric QUIK-ALIGN collar. Contact the vehicle manufacturer for specifications.

WARNING

DISCARD USED QUIK-ALIGN FASTENERS. ALWAYS USE NEW QUIK-ALIGN FASTENERS TO COMPLETE A REPAIR. FAILURE TO DO SO COULD RESULT IN FAILURE OF THE PART, OR MATING COMPONENTS, ADVERSE VEHICLE HANDLING, PERSONAL INJURY, OR PROPERTY DAMAGE.

DO NOT ASSEMBLE QUIK-ALIGN JOINT WITHOUT THE PROPER FASTENERS. USE ONLY H-COATED FASTENERS TO SUSTAIN PROPER CLAMP FORCE. FAILURE TO DO SO CAN CAUSE ADVERSE VEHICLE HANDLING, PROPERTY DAMAGE OR PERSONAL INJURY AND VOID WARRANTY. ENSURE THAT THE QUIK-ALIGN FASTENER'S TORQUE VALUES ARE SUSTAINED AS RECOMMENDED IN THE TORQUE SPECIFICATIONS SECTION OF THIS PUBLICATION. FAILURE TO DO SO CAN CAUSE ADVERSE VEHICLE HANDLING RESULTING IN PERSONAL INJURY OR PROPERTY DAMAGE. FOLLOW VEHICLE MANUFACTURER'S FASTENER ORIENTATION WHEN PERFORMING ANY MAINTENANCE, SERVICE OR REPAIR.

1. Support the frame at ride height.

WARNING

PRIOR TO AND DURING DEFLATION AND INFLATION OF THE AIR SUSPENSION SYSTEM, ENSURE THAT ALL PERSONNEL AND EQUIPMENT ARE CLEAR FROM UNDER THE VEHICLE AND AROUND THE SERVICE AREA, FAILURE TO DO SO CAN CAUSE SERIOUS PERSONAL INJURY, DEATH, OR PROPERTY DAMAGE.

2. See additional Air Spring Warnings and Instructions in the Important Safety Notice Section of this publication prior to deflating or inflating the suspension system.
3. Disconnect the height control linkage assembly from the height control valve arm. Lower the height control valve arm to exhaust the air in the air springs and deflate the rear suspension. (See vehicle manufacturer's instructions).

WARNING

SOME VEHICLE APPLICATIONS, SUCH AS VEHICLES EQUIPPED WITH OUTRIGGERS, RETAIN SOME AIR PRESSURE IN THE AIR SPRINGS AT ALL TIMES. PRIOR TO PERFORMING ANY MAINTENANCE, SERVICE, OR REPAIR OF THE SUSPENSION, VERIFY EACH AIR SPRING IS COMPLETELY DEFLATED. FAILURE TO DO SO COULD RESULT SERIOUS PROPERTY DAMAGE AND/OR SEVERE PERSONAL INJURY.

4. Using the measurements from the Drive Axle Alignment Inspection Procedure, Step 11, determine which QUIK-ALIGN collar will need adjusting to correct the axle alignment.

SERVICE HINT

If the axle can be adjusted on both sides, begin the adjustment on the side that is furthest out of specification.

NOTE

Use a new QUIK-ALIGN pivot bolt kit (see the Parts List Section of this publication) for any axle alignment or disassembly of the QUIK-ALIGN connection. This will help ensure that the proper clamp load is applied to the connection and help prevent the joint to slip in service.

5. On the side being adjusted, remove the old QUIK-ALIGN fastener and replace it with a new QUIK-ALIGN fastener. Snug the QUIK-ALIGN fastener to 50-100 foot pounds. **DO NOT** tighten to torque at this time, see Figure 7-8. This will hold the eccentric flanged collar in place against the frame hanger face, and within the adjustment guide, but loose enough to permit the QUIK-ALIGN eccentric flanged collar to rotate freely.
6. Inflate the suspension by connecting the height control valve linkage to the height control valve arm. Verify the air springs inflate uniformly without binding.
7. Verify correct ride height.

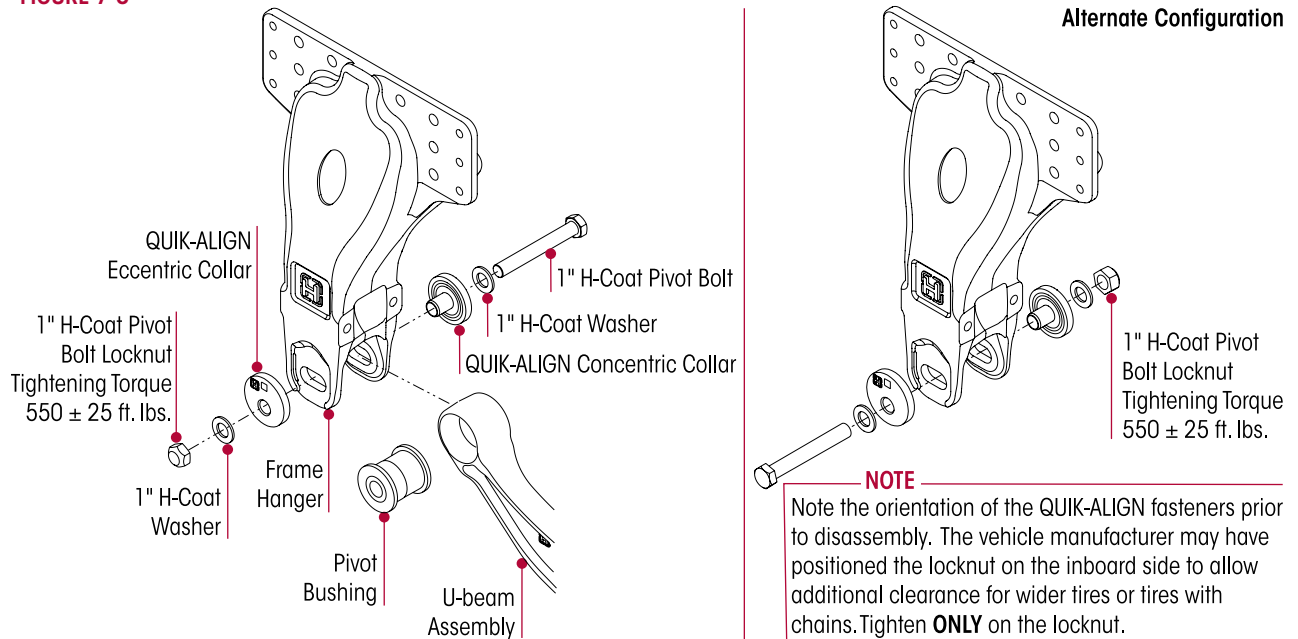
FIGURE 7-8

NOTE

When adjusting the alignment of an axle, the fasteners connecting the longitudinal torque rod to the frame hanger, above the QUIK-ALIGN collar being adjusted, must be loose at the frame hanger. This will allow the longitudinal torque rod to move freely with the axle while the alignment is adjusted. Failure to do so will result in bushing preload in all rubber connections on that side of the axle, shortening component life.

8. On the side of the axle being adjusted, loosen the fasteners connecting the longitudinal torque rod to the frame hanger. Remove any existing shims from this connection. Leave connection loose at this time.
9. Use a QUIK-ALIGN socket tool, Figure 7-9 (also see Tool Section of this publication) and impact gun, see Figure 7-10, or a ½" square drive breaker bar to rotate the QUIK-ALIGN eccentric collar to align the axle.
10. Once the correct axle alignment is achieved, use a calibrated torque wrench to tighten the 1" QUIK-ALIGN locknuts to 550 ± 25 foot pounds torque.
11. Fill any gap between the frame hanger and longitudinal torque rod with shims.
12. Tighten the longitudinal torque rod fasteners to the proper specification, see Torque Specification Section of this publication per model designation.

FIGURE 7-9

FIGURE 7-10

13. Re-check the ride height and the axle alignment to verify they are within the vehicle manufacturer's specifications. See Rear Axle Alignment Inspection in this Section.
14. Return to the Drive Axle Alignment Inspection Procedure, Step 12, for the remaining drive axles.

PINION ANGLE ADJUSTMENT

ADJUSTMENT OF 1.5 DEGREES OR LESS

NOTE When correcting the pinion angle of an axle the correction must be in equal amounts on both sides of the axle. However, the total number of shims per side may differ due to axle alignment.

SERVICE HINT A general rule of thumb is, 1/8" change in the shim pack thickness will increase or decrease the pinion angle by 1/2 degree.

1. Loosen the fasteners connecting the longitudinal torque rods to the frame hangers.
2. Install or remove shims as required in **equal amounts** to both sides of the axle to achieve the proper pinion angle, see Figure 7-11. Therefore, to increase the pinion angle install shims, to decrease the pinion angle remove shims.
3. Tighten the longitudinal torque rod fasteners to the proper specification, see Torque Specification Section of this publication per model designation.
4. Re-check the pinion angle and verify it is within the vehicle manufacturer's specifications.

ADJUSTMENT OF MORE THAN 1.5 DEGREES

If an adjustment of more than 1.5 degrees is required, it will be necessary to replace the bottom cap with a bottom cap that will achieve the desired pinion angle. After replacement of the bottom cap perform the drive axle alignment procedure. See Pinion Angle Chart in the Parts List Section of this publication.

FIGURE 7-11



SECTION 8

Component Replacement

FASTENERS

When servicing a vehicle, Hendrickson recommends replacing all removed fasteners with new equivalent fasteners. Maintain correct torque values at all times. Check torque values as specified. See Hendrickson's Torque Specifications Section of this publication. If non-Hendrickson fasteners are used follow torque specifications listed in the vehicle manufacturer's service manual.

AIR SPRING / UPPER AIR SPRING BRACKET

DISASSEMBLY

1. Chock the wheels of the vehicle.

 **WARNING**

PRIOR TO AND DURING DEFLATION AND INFLATION OF THE AIR SUSPENSION SYSTEM, ENSURE THAT ALL PERSONNEL AND EQUIPMENT ARE CLEAR FROM UNDER THE VEHICLE AND AROUND THE SERVICE AREA, FAILURE TO DO SO CAN CAUSE SERIOUS PERSONAL INJURY, DEATH, OR PROPERTY DAMAGE.

2. See additional Air Spring Cautions and Warnings in the Important Safety Notice Section of this publication prior to deflating or inflating the air system.
3. Disconnect the height control linkage assembly from the height control valve arm by sliding the rubber grommet off the height control valve arm's stud. Lower the height control valve arm(s) to exhaust the air in the air springs and deflate the rear suspension.

 **WARNING**

SOME VEHICLE APPLICATIONS, SUCH AS VEHICLES EQUIPPED WITH OUTRIGGERS, RETAIN SOME AIR PRESSURE IN THE AIR SPRINGS AT ALL TIMES. PRIOR TO PERFORMING ANY MAINTENANCE, SERVICE, OR REPAIR OF THE SUSPENSION, VERIFY EACH AIR SPRING IS COMPLETELY DEFLATED. FAILURE TO DO SO COULD RESULT SERIOUS PROPERTY DAMAGE AND/OR SEVERE PERSONAL INJURY.

4. Remove the air lines from the air spring.
5. Remove the air line fitting from the air spring.

 **CAUTION**

IF THE AIR SPRING IS BEING REMOVED FOR AN ALTERNATE REPAIR, IT IS MANDATORY TO LUBRICATE THE LOWER AIR SPRING FASTENERS WITH PENETRATING OIL AND REMOVE WITH HAND TOOLS TO PREVENT DAMAGE TO THE LOWER AIR SPRING MOUNTING STUD. FAILURE TO DO SO CAN CAUSE COMPONENT DAMAGE AND VOID WARRANTY.

6. If the air spring is being removed for an alternate repair it will be necessary to clean and lubricate the lower mounting fasteners with penetrating oil. This will help prevent the air spring mounting studs from breaking during the removal process. Remove the lower mounting fasteners from the air springs using **HAND TOOLS** only.
7. Remove the lower air spring mounting bracket from the cross tube.
8. Remove and discard the fasteners securing the air spring to the upper air spring bracket assembly.
9. Remove the air spring.
10. Remove and discard the fasteners securing the upper air spring bracket assembly to the frame rail per vehicle manufacturer's specifications.
11. Inspect the upper air spring bracket assembly, mounting surfaces and lower air spring mounting bracket for any damage. Replace as necessary.

ASSEMBLY

1. Loosely attach the upper air spring bracket assembly to the frame rail.
2. Press the upper air spring bracket assembly against the underside of the frame and tighten the frame fasteners to the proper torque per the original equipment manufacturers specifications.

WARNING

FAILURE TO PRESS THE UPPER AIR SPRING BRACKET ASSEMBLY AGAINST THE UNDERSIDE OF THE FRAME WHILE TIGHTENING THE UPPER AIR SPRING FASTENERS CAN RESULT IN COMPONENT DAMAGE AND PERSONAL INJURY OR PROPERTY DAMAGE.

3. Attach the air spring to the upper air spring bracket assembly and tighten the locknuts to proper torque specifications, see Torque Specification Section in this publication.
4. Install the air spring between the frame and the cross tube. Ensure the **air spring slot** in the bottom of the air spring engages the **beam notch** on the top of the beam, see Figure 8-1.
5. Install the lower air spring mounting bracket around the cross tube, engaging the mounting air spring studs, see Figure 8-1.
6. Using **HAND TOOLS** only, install the lower mounting locknuts and tighten to 25 ± 5 foot pounds torque, see Figure 8-1.
7. Install the air line fitting to the air spring using Teflon (or equivalent) thread seal.
8. Connect the air line to the air spring.

WARNING

PRIOR TO AND DURING DEFLATION AND INFLATION OF THE AIR SUSPENSION SYSTEM, ENSURE THAT ALL PERSONNEL AND EQUIPMENT ARE CLEAR FROM UNDER THE VEHICLE AND AROUND THE SERVICE AREA, FAILURE TO DO SO CAN CAUSE SERIOUS PERSONAL INJURY, DEATH, OR PROPERTY DAMAGE.

9. See additional Air Spring Cautions and Warnings in the Important Safety Notice Section of this publication prior to deflating or inflating the air system.
10. Inflate the suspension slowly and verify that the air spring bladder inflates uniformly without binding.
11. Reconnect the height control linkage assembly to the height control valve arm.
12. Remove the frame supports.
13. Verify proper ride height. Refer to the Alignment & Adjustments Section of this publication.
14. Remove the wheel chocks.

FIGURE 8-1

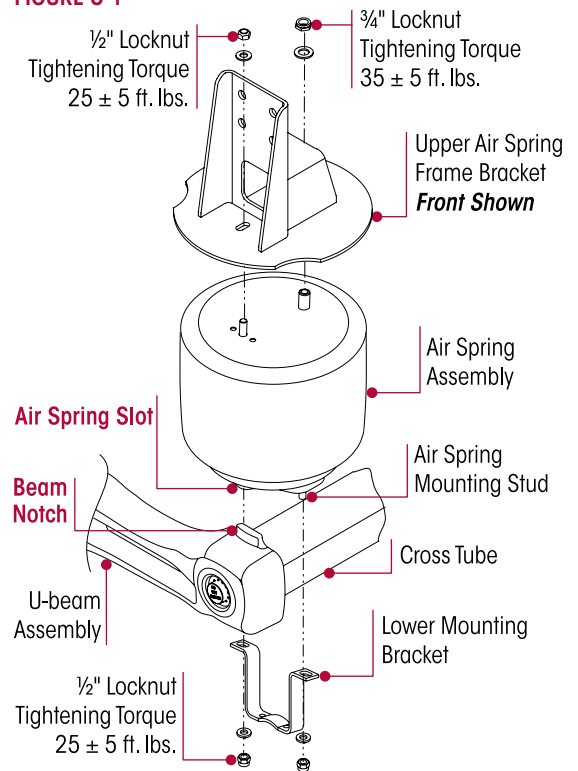

HEIGHT CONTROL VALVE

NOTE

This procedure is for servicing a height control valve supplied by Hendrickson. Contact the vehicle manufacturer for instructions when servicing a non-Hendrickson height control valve.

DISASSEMBLY

1. Chock the wheels of the vehicle.

WARNING

PRIOR TO AND DURING DEFLATION AND INFLATION OF THE AIR SUSPENSION SYSTEM, ENSURE THAT ALL PERSONNEL AND EQUIPMENT ARE CLEAR FROM UNDER THE VEHICLE AND AROUND THE SERVICE AREA, FAILURE TO DO SO CAN CAUSE SERIOUS PERSONAL INJURY, DEATH, OR PROPERTY DAMAGE.

2. See additional Air Spring Cautions and Warnings in the Important Safety Notice Section of this publication prior to deflating or inflating the air system.
3. Disconnect the height control linkage assembly from the height control valve arm by sliding the rubber grommet off the height control valve arm's stud. Lower the height control valve arm(s) to exhaust the air in the air springs and deflate the rear suspension.

WARNING

SOME VEHICLE APPLICATIONS, SUCH AS VEHICLES EQUIPPED WITH OUTRIGGERS, RETAIN SOME AIR PRESSURE IN THE AIR SPRINGS AT ALL TIMES. PRIOR TO PERFORMING ANY MAINTENANCE, SERVICE, OR REPAIR OF THE SUSPENSION, VERIFY EACH AIR SPRING IS COMPLETELY DEFLATED. FAILURE TO DO SO COULD RESULT SERIOUS PROPERTY DAMAGE AND/OR SEVERE PERSONAL INJURY.

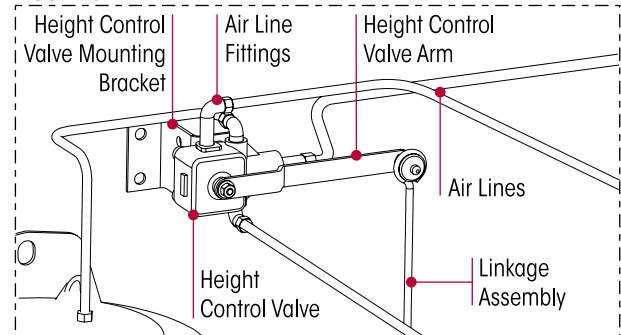
FIGURE 8-2

4. Remove the air lines from the height control valve.
5. Remove and discard the locknut fasteners that attach the height control valve to the frame mounting bracket. **DO NOT** back out the studs from the height control valve body. Loosening the studs may cause the height control valve to leak.
6. Remove the height control valve, see Figure 8-2.
7. Remove the air line fittings from the height control valve.

ASSEMBLY

1. Install the air line fittings into the height control valve using Teflon (or equivalent) thread seal.
2. Install the height control valve to the frame mounting bracket by attaching the ¼" washers and locknuts. Tighten to 9 ± 1 foot pounds torque.
3. Install the air lines to the height control valve. Refer to the Plumbing Diagrams Section of this publication.
4. See additional Air Spring Cautions and Warnings in the Important Safety Notice Section of this publication prior to deflating or inflating the air system.
5. Inflate the suspension slowly and verify that the air spring bladder inflates uniformly without binding.
6. Reconnect the height control linkage assembly to the height control valve arm.
7. Verify proper ride height adjustment, see Ride Height Adjustment in the Preventive Maintenance Section of this publication.
8. Remove the wheel chocks.

SHOCK ABSORBER

DISASSEMBLY

1. Chock the wheels of the vehicle.

NOTE

If removal of the height control valve linkage bracket is necessary for shock absorber replacement, mark the position of the linkage bracket to facilitate reinstallation.

2. Remove and discard the **lower** shock absorber mounting fasteners and, if necessary, the height control valve linkage bracket, see Figure 8-3.
3. Remove and discard the **upper** shock absorber mounting fasteners.
4. Slide the shock absorber out of the **upper** shock frame bracket.
5. Inspect the shock absorber mounting brackets and hardware for damage or wear. Replace if necessary.

ASSEMBLY

1. Install the upper shock absorber mounting bracket (if removed).
2. Install the shock absorber into the upper shock frame bracket.
3. Install the upper shock absorber mounting fasteners.
4. Slide the lower shock absorber mount into the bottom cap.
5. Install the lower shock absorber mounting fasteners and height control valve linkage bracket (if removed).
6. Tighten the upper shock absorber mounting locknut to \mathbb{R} 188 ± 12 foot pounds torque, see Figure 8-3.
7. Tighten the lower shock absorber mounting locknut to \mathbb{R} 213 ± 12 foot pounds torque, see Figure 8-3.
8. If the height control valve linkage bracket was removed, verify the vehicle ride height. Refer to the Alignment & Adjustments Section of this publication.
9. Remove the wheel chocks.

FIGURE 8-3

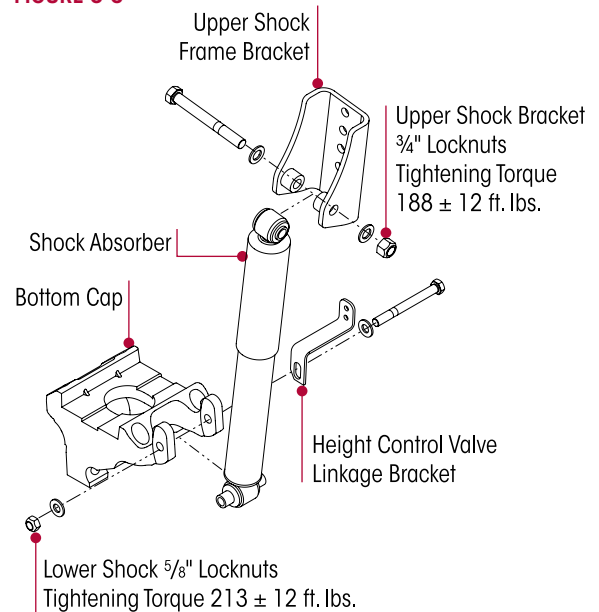

TRANSVERSE TORQUE ROD

WARNING

THE PRIMAAX EX SUSPENSION INCORPORATES TRANSVERSE TRAAX RODS FOR VEHICLE STABILITY. IF THESE COMPONENTS ARE DISCONNECTED OR ARE NON-FUNCTIONAL THE VEHICLE SHOULD NOT BE OPERATED. FAILURE TO DO SO CAN RESULT IN ADVERSE VEHICLE HANDLING, POSSIBLE TIRE CONTACT WITH THE FRAME, SEVERE PERSONAL INJURY, AND PREMATURE COMPONENT DAMAGE.

NOTE

TRAAX ROD rod assemblies equipped on the PRIMAAX EX suspension for Mack HDT vehicles are not re-bushable. The entire torque rod assembly must be replaced. This feature provides superior bushing retention in the torque rod end hub.

DISASSEMBLY

1. Chock the wheels of the vehicle.

SERVICE HINT

Note the quantity and location of shims removed to maintain the lateral alignment of the axle during assembly. See Alignment & Adjustments Section of this publication.

2. Remove and discard the torque rod mounting fasteners.
3. Remove the transverse torque rod.
4. Inspect the mounting surfaces for any wear or damage. Repair or replace as necessary.

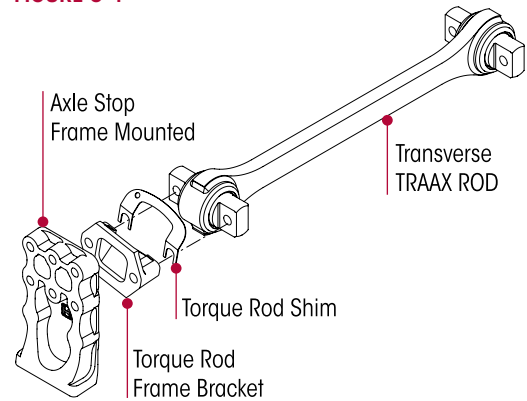
FIGURE 8-4

ASSEMBLY

1. Install the transverse torque rod.
2. Install the mounting fasteners, supplied by vehicle manufacturer, and any shims that were removed, see Figure 8-4.

NOTE

Hendrickson recommends using Grade 8 bolts and Grade C locknuts for all torque rod attachments.

3. Prior to tightening, ensure that the vehicle is at the proper ride height.
4. Tighten all fasteners to the vehicle manufacturer's torque specifications.
5. Check the lateral alignment. If not within vehicle manufacturer's specified range, a lateral alignment is necessary. See Lateral Alignment in the Alignment & Adjustments Section of this publication.
6. Remove the wheel chocks.

LONGITUDINAL TORQUE ROD
NOTE

Torque rod assemblies equipped on the PRIMAAX EX suspension for Mack HDT vehicles have curled end hubs and are not re-bushable. The entire torque rod assembly must be replaced. This feature provides superior bushing retention in the torque rod end hub.

DISASSEMBLY

1. Chock the wheels of the vehicle.

SERVICE HINT

Note the quantity of shims removed to maintain the correct pinion angle of the axle at assembly. See Alignment & Adjustments Section of this publication.

2. Remove and discard the fasteners and shims (if equipped) that connect the longitudinal torque rod to frame hanger, see Figure 8-5.
3. Remove and discard the fasteners that connect the longitudinal torque rod to top pad, see Figure 8-5.
4. Remove the longitudinal torque rod.
5. Inspect the mounting surfaces for any wear or damage, replace if necessary.

ASSEMBLY

1. Install the longitudinal torque rod.
2. Install the fasteners and any shims that were removed, see Figure 8-5.

FIGURE 8-5

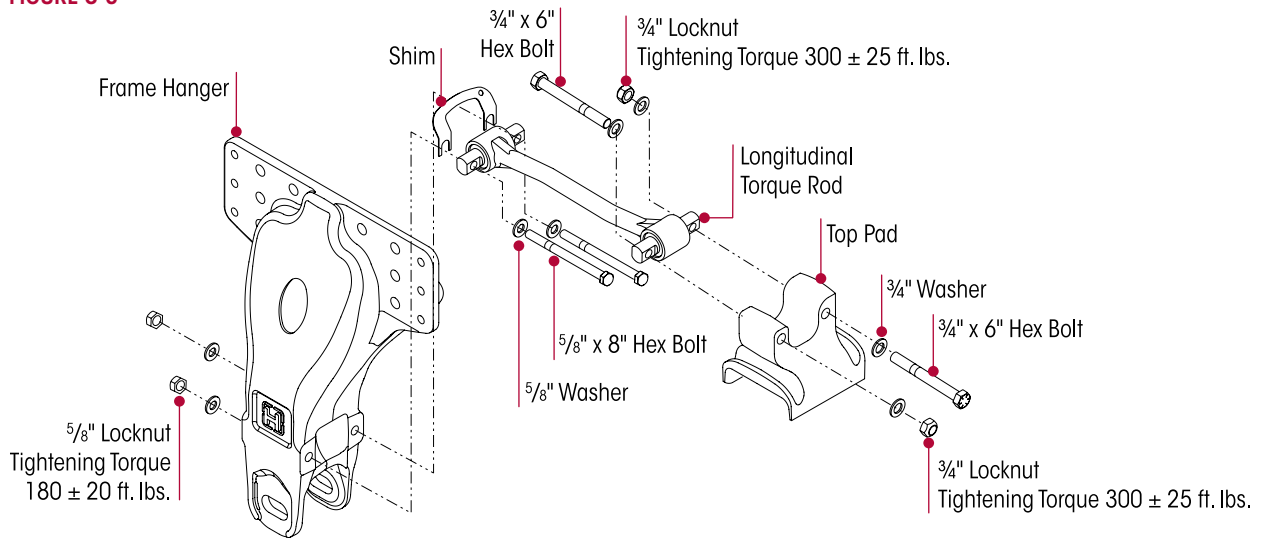

NOTE Hendrickson recommends the use of Grade 8 bolts and Grade C locknuts be used for all torque rod attachments.

NOTE It is mandatory to have the vehicle at proper ride height prior to tightening the $\frac{3}{4}$ " straddle bushing and the $\frac{7}{8}$ " top pad through bolt locknuts to torque specifications.

3. Tighten the $\frac{3}{4}$ " longitudinal to top pad fasteners to \mathbb{R} 300 \pm 25 foot pounds torque.
4. Tighten the $\frac{5}{8}$ " longitudinal to frame hanger fasteners to \mathbb{R} 180 \pm 20 foot pounds torque.
5. When assembly is complete check the drive axle pinion angles, see the Alignment & Adjustments Section of this publication.
6. Remove the wheel chocks.

U-BEAM ASSEMBLY

DISASSEMBLY

1. Chock the front wheels.
2. Support the frame at ride height.
3. Raise and support the axle being serviced. Remove the wheels.
4. Disconnect the height control valve linkage assembly from the height control valve arm(s), see vehicle manufacturer's instructions.

WARNING

PRIOR TO AND DURING DEFLATION AND INFLATION OF THE AIR SUSPENSION SYSTEM, ENSURE THAT ALL PERSONNEL AND EQUIPMENT ARE CLEAR FROM UNDER THE VEHICLE AND AROUND THE SERVICE AREA, FAILURE TO DO SO CAN CAUSE SERIOUS PERSONAL INJURY, DEATH, OR PROPERTY DAMAGE.

WARNING

SOME VEHICLE APPLICATIONS, SUCH AS VEHICLES EQUIPPED WITH OUTRIGGERS, RETAIN SOME PRESSURE IN THE AIR SPRINGS AT ALL TIMES. PRIOR TO PERFORMING ANY MAINTENANCE, SERVICE, OR REPAIR OF THE SUSPENSION, VERIFY EACH AIR SPRING IS COMPLETELY DEFLATED. FAILURE TO DO SO COULD RESULT IN SERIOUS PROPERTY DAMAGE AND/OR SEVERE PERSONAL INJURY.

5. See additional Air Spring Cautions and Warnings in the Important Safety Notice Section of this publication prior to deflating or inflating the air system.
6. Lower the height control valve arm(s) to exhaust the air in the air springs and deflate the rear suspension.

CAUTION

IF THE AIR SPRING IS BEING REMOVED FOR AN ALTERNATE REPAIR, IT IS MANDATORY TO LUBRICATE THE LOWER AIR SPRING FASTENERS WITH PENETRATING OIL AND REMOVE WITH HAND TOOLS TO PREVENT DAMAGE TO THE LOWER AIR SPRING MOUNTING STUD. FAILURE TO DO SO CAN CAUSE COMPONENT DAMAGE AND VOID WARRANTY.

7. Lubricate the lower mounting fasteners of the air springs with penetrating oil. This will help prevent the air spring mounting studs from breaking during the removal process.
8. Remove and discard the lower mounting fasteners from the air springs using **HAND TOOLS** only.
9. Remove both the lower air spring mounting brackets to disconnect both air springs from the cross tube, see Figure 8-6.

WARNING

IT IS MANDATORY TO USE A FLOOR JACK EQUIPPED WITH A FOUR INCH CONTACT PLATE TO SUPPORT THE U-BEAM ASSEMBLY AT THE CROSS TUBE TO FACILITATE SAFE LOWERING AND RAISING OF THE U-BEAM ASSEMBLY. DO NOT USE A BOTTLE JACK. A BOTTLE JACK DOES NOT HAVE ENOUGH CONTACT AREA AND CAN BE UNSTABLE. FAILURE TO DO SO CAN CAUSE COMPONENT DAMAGE OR RESULT IN PERSONAL INJURY.

10. Install a floor jack with a 4" contact plate to support the U-beam assembly at the cross tube.

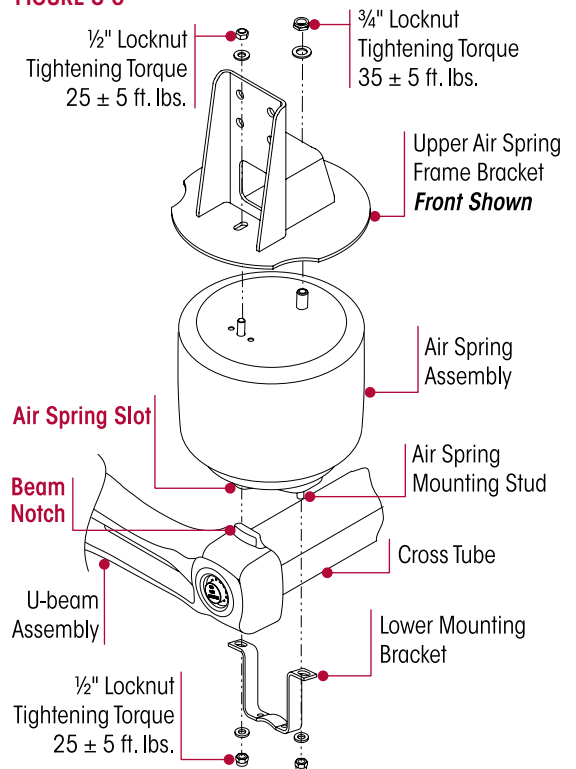
FIGURE 8-6

SERVICE HINT

Each frame hanger will have a pair of QUIK-ALIGN collars. Note which type of QUIK-ALIGN collar is removed from which frame hanger location to facilitate the assemble process. Any eccentric (with the square drive feature) QUIK-ALIGN collar should be mounted on the outboard side of the frame hanger. Axle thrust angles can only be corrected on frame hangers equipped with eccentric QUIK-ALIGN collars.

11. Mark the position of the QUIK-ALIGN square drive in relationship to the frame hanger prior to loosening the QUIK-ALIGN connection. This will facilitate the axle alignment process after the repair is complete.
12. Loosen both the QUIK-ALIGN fasteners, **DO NOT** remove at this time.
13. Remove and discard D-pin fasteners on both sides of the suspension.

SERVICE HINT

It may be necessary to rotate the QUIK-ALIGN eccentric collars to allow the full disengagement of the D-pins into the bottom caps.

SERVICE HINT

It may be necessary to raise the front of the differential to allow the D-pins to disengage the bottom caps.

WARNING

THE WEIGHT OF THE U-BEAM ASSEMBLY IS APPROXIMATELY 225 POUNDS. CARE SHOULD BE TAKEN AT REMOVAL AND INSTALLATION TO PREVENT PERSONAL INJURY OR DAMAGE TO COMPONENTS.

14. Lower the floor jack and pivot the U-beam assembly down.
15. Remove and discard the QUIK-ALIGN fasteners.
16. Remove QUIK-ALIGN eccentric and concentric collars.

NOTE

It may be necessary to use a pry bar to push the U-beam assembly out of the frame hangers.

17. Remove the U-beam assembly from the hangers.
18. Remove the U-beam assembly from the vehicle.
19. Inspect the U-beam assembly for any damage or wear and replace as necessary.

ASSEMBLY

1. Clean the QUIK-ALIGN slots in the hangers and collars of any dirt and debris and inspect for any wear or damage. Replace as necessary.
2. Prior to installing the U-beam assembly, verify the clamp group is tightened to the proper torque.

WARNING

THE WEIGHT OF THE U-BEAM ASSEMBLY IS APPROXIMATELY 225 POUNDS. CARE SHOULD BE TAKEN AT REMOVAL AND INSTALLATION TO PREVENT PERSONAL INJURY OR DAMAGE TO COMPONENTS.

3. Install the U-beam assembly into the frame hangers.

WARNING

DISCARD USED QUIK-ALIGN FASTENERS. ALWAYS USE NEW QUIK-ALIGN FASTENERS TO COMPLETE A REPAIR. FAILURE TO DO SO COULD RESULT IN FAILURE OF THE PART, OR MATING COMPONENTS, ADVERSE VEHICLE HANDLING, PERSONAL INJURY, OR PROPERTY DAMAGE.

WARNING

DO NOT ASSEMBLE QUIK-ALIGN JOINT WITHOUT THE PROPER FASTENERS. USE ONLY H-COATED FASTENERS TO SUSTAIN PROPER CLAMP FORCE. FAILURE TO DO SO CAN CAUSE ADVERSE VEHICLE HANDLING, PROPERTY DAMAGE OR PERSONAL INJURY AND VOID WARRANTY. ENSURE THAT THE QUIK-ALIGN FASTENER'S TORQUE VALUES ARE SUSTAINED AS RECOMMENDED IN THE TORQUE SPECIFICATIONS SECTION OF THIS PUBLICATION. FAILURE TO DO SO CAN CAUSE ADVERSE VEHICLE HANDLING RESULTING IN PERSONAL INJURY OR PROPERTY DAMAGE. FOLLOW VEHICLE MANUFACTURER'S FASTENER ORIENTATION WHEN PERFORMING ANY MAINTENANCE, SERVICE OR REPAIR.

NOTE

Use a new QUIK-ALIGN pivot bolt kit (see the Parts List Section of this publication) for any axle alignment or disassembly of the QUIK-ALIGN connection. This will help ensure that the proper clamp load is applied to the connection and help prevent the joint to slip in service.

4. Verify the correct QUIK-ALIGN collar (eccentric/concentric) is in the correct location as noted in the disassembly procedure.
5. Install QUIK-ALIGN connection with new Hendrickson fasteners and snug to about  50-100 foot pounds torque, **DO NOT** tighten at this time. The final torque must be done after the alignment is complete.
6. Position the U-beam assembly on a floor jack.
7. Raise the U-beam assembly until the D-pins engage in the bottom cap.

SERVICE HINT

It may be necessary to rotate the QUIK-ALIGN eccentric collars to allow the full engagement of the D-pins into the bottom caps.

SERVICE HINT

It may be necessary to raise or lower the front of the differential to allow the D-pins to engage in the bottom cap. Use a drift pin if necessary to align the D-pins with the bottom cap.



8. Install the D-pin fasteners from front to back, see Figure 8-7.
9. Remove the floor jack supporting the U-beam assembly.
10. Tighten D-Pin fasteners to  300 ± 25 foot pounds torque.
11. Install the air spring between the frame and the cross tube, see Figure 8-8. Ensure the **air spring slot** in the bottom of the air spring engages the **beam notch** on the top of the support beam.
12. Install the lower air spring mounting bracket around the cross tube, engaging the mounting air spring studs, see Figure 8-8.
13. Using **HAND TOOLS** install the lower mounting fasteners and tighten to  25 ± 5 foot pounds torque.
14. Install the wheels and remove axle support.

FIGURE 8-7

15. See additional Air Spring Cautions and Warnings in the Important Safety Notice Section of this publication prior to deflating or inflating the air system.
16. Connect the linkage to the height control valve arm(s) to inflate the suspension, see vehicle manufacturer's instructions.
17. Remove frame support(s).
18. Remove the wheel chocks.



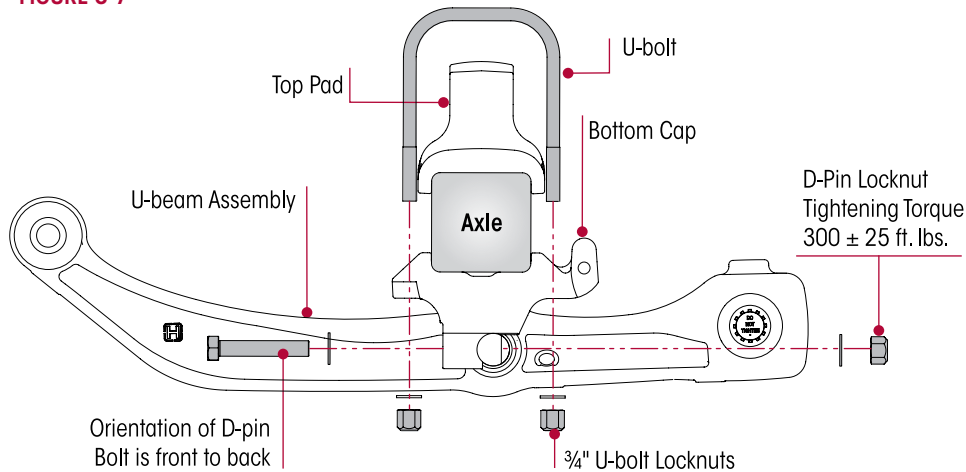

NOTE

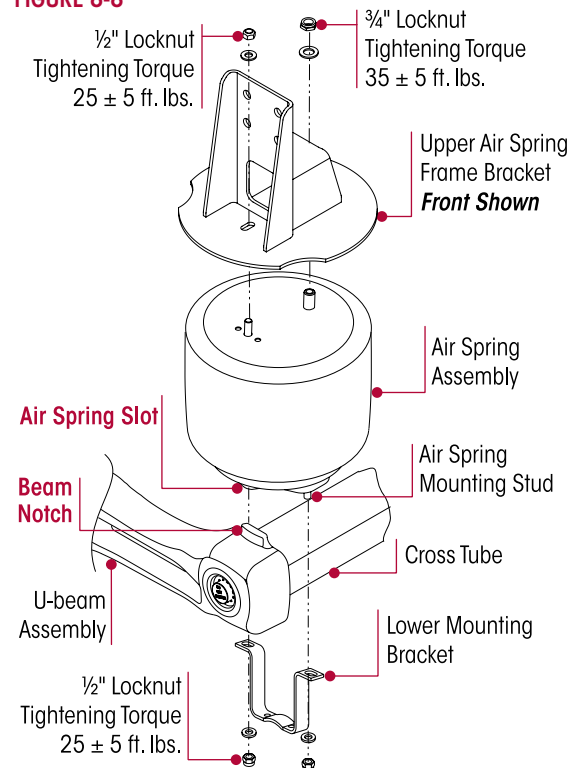
Alignment and QUIK-ALIGN final torque is necessary anytime the U-beam assembly is removed.

19. Check the alignment and adjust if necessary. See Alignment & Adjustments Section of this publication.
20. Once the correct axle alignment is achieved, use a calibrated torque wrench to tighten the 1" QUIK-ALIGN locknuts to 500 ± 25 foot pounds torque.

FIGURE 8-8

D-PIN BUSHING
YOU WILL NEED:

- Hendrickson Tool Part Nos. 66086-204 • 66086-202 (OTC Nos. 4247 • 4246), refer to the *Special Tools Section of this publication*

REMOVAL		✓	✓	✓
INSTALLATION	✓		✓	✓
D-pin	575164 Saddle 	575163 Adapter Pin 	576421 D-pin Adapter 	575167 Alignment Tool 

DISASSEMBLY

1. Mark the spring to show the alignment of the existing D-pin. Install the alignment tool over the D-pin, and place the clamping plate over the alignment tool, see Figure 8-9.
2. Assemble the clamping nuts to the threaded rods.
3. Insert a threaded rod through the upper holes in the clamping plate and the head plate. Install a hex nut on the threaded rod, but **DO NOT** tighten at this time.
4. Insert a threaded rod through the lower holes in the clamping plate and the head plate. Install a hex nut on the threaded rod, but **DO NOT** tighten at this time.
5. Tighten the clamping nuts to the clamping plate, see Figure 8-10.

FIGURE 8-9

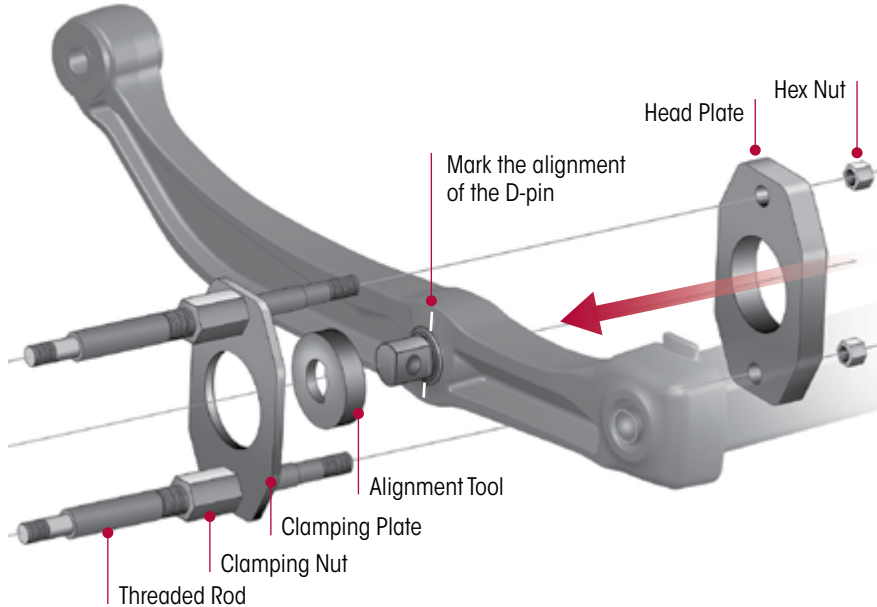
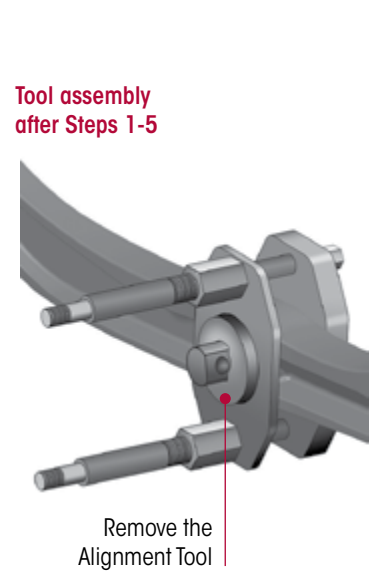

FIGURE 8-10



6. Remove the alignment tool.

WARNING

TO PREVENT PERSONAL INJURY, THE CYLINDER MUST BE FULLY THREADED INTO THE CYLINDER MOUNTING PLATE.

7. Thread the cylinder into the cylinder mounting plate, see Figure 8-11.

FIGURE 8-11

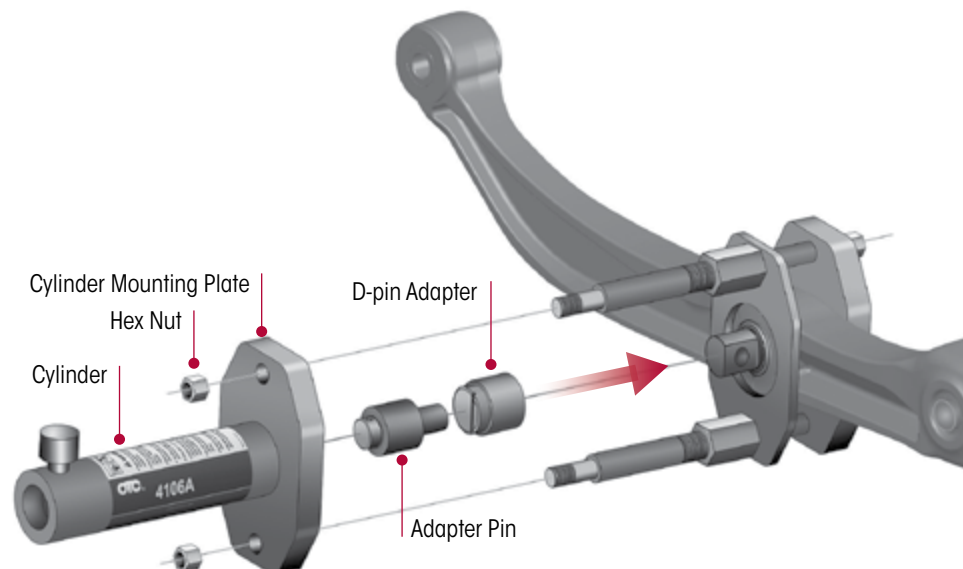

8. Install the cylinder mounting plate onto the end of the threaded rods. Adjust the clamping nuts as needed to fit the threaded rods through the holes in the cylinder mounting plate. Assemble the hex nuts on the threaded rods. Tighten the hex nuts on both ends of the threaded rods.
9. Place the D-pin adapter over the D-pin.
10. Insert the adapter pin into the head of the cylinder.
11. Prepare the hydraulic pump for use by following the instructions provided with the pump regarding hookup, venting, priming, and operation.

WARNING

TO PREVENT PERSONAL INJURY, PUMP CAPACITY MUST NOT EXCEED 10,000 PSI.

12. Connect the hydraulic hose from the hydraulic pump to the cylinder.
13. Operate the pump to extend the cylinder piston and apply pressure to push the D-pin out of the spring.

WARNING

TO PREVENT PERSONAL INJURY FROM POSSIBLE BREAKAGE UNDER PRESSURE, DO NOT STAND IN THE VICINITY OF THE TOOL WHILE THE D-PIN IS BEING EXTRACTED. IT IS ESPECIALLY IMPORTANT TO NOT STAND IN THE DIRECTION OF THE HYDRAULIC FORCE.

ASSEMBLY

1. Clean and thoroughly lubricate the entire surface of the inside diameter of the spring, see Figure 8-12.
2. Insert the saddle into the head of the cylinder.
3. Assemble the new D-pin and the D-pin adapter as shown. Align the line in the D-pin adapter with the alignment marks made during the removal procedure.
4. Operate the pump to extend the cylinder piston and apply enough pressure to hold the tool and components. Check the alignment of the D-pin. The centerline of the D-pin must be aligned with the centerline of the inside diameter of the spring.

WARNING

TO PREVENT PERSONAL INJURY, PUMP CAPACITY MUST NOT EXCEED 10,000 PSI.

5. Operate the pump to apply pressure to install the D-pin completely into the spring.

WARNING

TO PREVENT PERSONAL INJURY FROM POSSIBLE BREAKAGE UNDER PRESSURE, DO NOT STAND IN THE VICINITY OF THE TOOL WHILE THE D-PIN IS BEING INSTALLED. IT IS ESPECIALLY IMPORTANT TO NOT STAND IN THE DIRECTION OF THE HYDRAULIC FORCE.

FIGURE 8-12

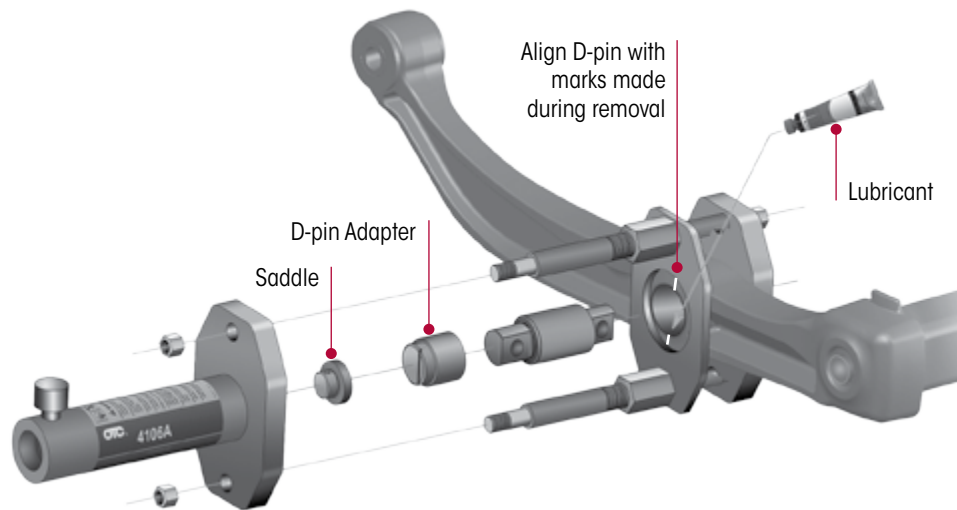





QUIK-ALIGN PIVOT BUSHING

- **Method A** – Using Tool Nos. 66086-204 • 66086-202
- **Method B** – Using Tool No. 66086-203L, see the procedure in this section or refer to Hendrickson Literature No. 59310-061

METHOD A – Using Tool Nos. 66086-204 • 66086-202

You will need:

- Hendrickson Tool Part Nos. 66086-204 • 66086-202 (OTC Nos. 4247 • 4246), refer to the Special Tools Section of this publication

REMOVAL	✓	✓	✓	✓
INSTALLATION	✓		✓	✓
	575163 Adapter Pin	576421 D-pin Adapter	575165 Bushing Support	575167 Alignment Tool
				

DISASSEMBLY

1. Insert the adapter pin through the alignment tool and into the pivot bushing hole as shown in Figure 8-13.
2. Insert the bushing support over the pivot bushing.
3. Assemble the clamping nuts to the threaded rods.
4. Insert a threaded rod through the upper holes in the clamping plate and the head plate while positioning the head plate over the bushing support. Install a hex nut on the threaded rod, but **DO NOT** tighten at this time.
5. Insert a threaded rod through the lower holes in the clamping plate and the head plate. Install a hex nut on the threaded rod, but **DO NOT** tighten at this time.
6. Tighten the clamping nuts to the clamping plate, see Figure 8-14.

FIGURE 8-13

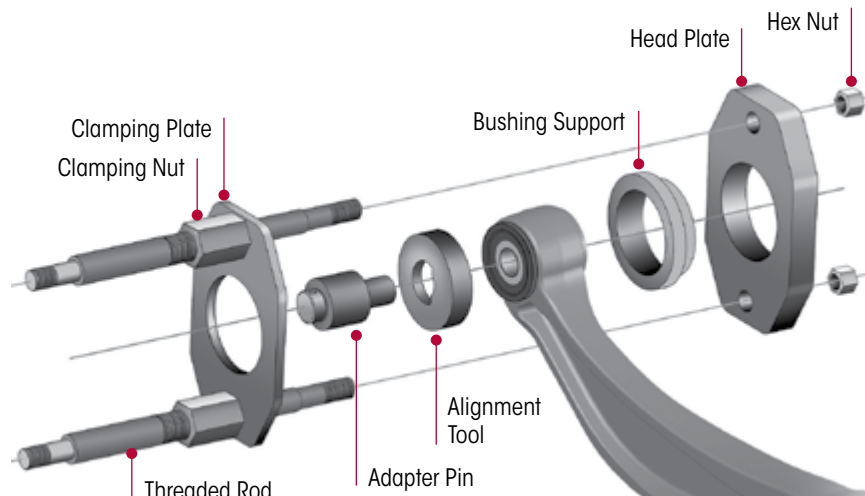
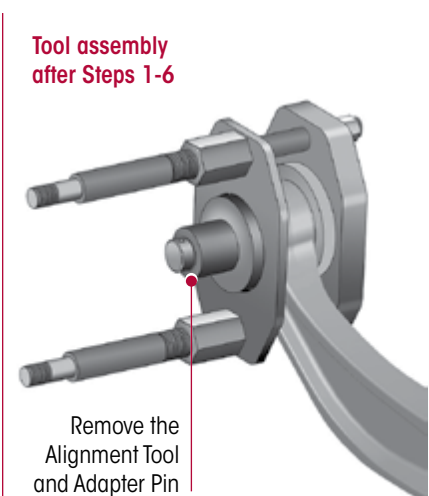

FIGURE 8-14



7. Remove the alignment tool and adapter pin.
8. Thread the cylinder into the cylinder mounting plate, see Figure 8-15.

WARNING

TO PREVENT PERSONAL INJURY, THE CYLINDER MUST BE FULLY THREADED INTO THE CYLINDER MOUNTING PLATE.

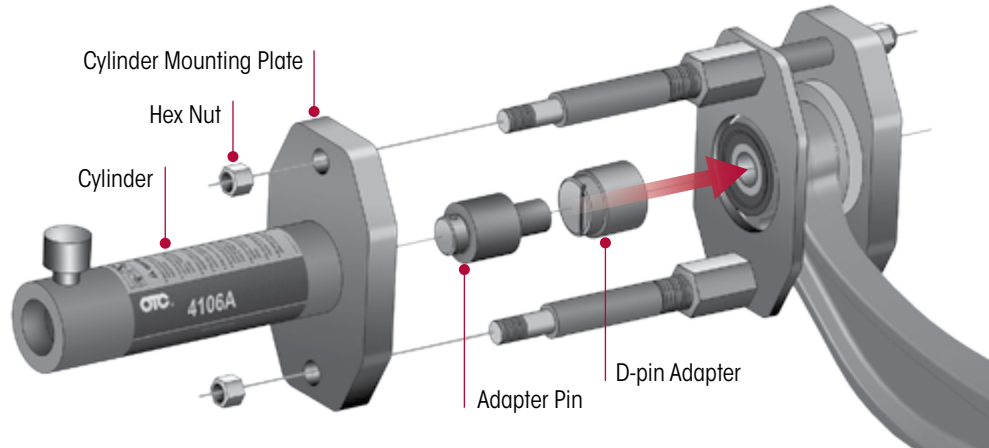
FIGURE 8-15

9. Install the cylinder mounting plate onto the end of the threaded rods. Adjust the clamping nuts as needed to fit the threaded rods through the holes in the cylinder mounting plate. Assemble the hex nuts on the threaded rods. Tighten the hex nuts on both ends of the threaded rods.
10. Hold the D-pin adapter over the pivot bushing until contact is made with the adapter pin.
11. Insert the adapter pin into the head of the cylinder.

WARNING

TO PREVENT PERSONAL INJURY, PUMP CAPACITY MUST NOT EXCEED 10,000 PSI.

12. Prepare the hydraulic pump for use by following the instructions provided with the pump regarding hookup, venting, priming, and operation.

WARNING

TO PREVENT PERSONAL INJURY FROM POSSIBLE BREAKAGE UNDER PRESSURE, DO NOT STAND IN THE VICINITY OF THE TOOL WHILE THE PIVOT BUSHING IS BEING EXTRACTED. IT IS ESPECIALLY IMPORTANT TO NOT STAND IN THE DIRECTION OF THE HYDRAULIC FORCE.

13. Connect the hydraulic hose from the hydraulic pump to the cylinder.
14. Operate the pump to extend the cylinder piston and apply pressure to push the pivot bushing out of the spring.

ASSEMBLY

1. Clean and thoroughly lubricate the entire surface of the inside diameter of the spring, see Figure 8-16.
2. Insert the adapter pin into the head of the cylinder.
3. Place the pivot bushing on the end of the adapter pin as shown.
4. Operate the pump to extend the cylinder piston and apply enough pressure to hold the tool and components. Check the alignment of the pivot bushing.

WARNING

TO PREVENT PERSONAL INJURY, PUMP CAPACITY MUST NOT EXCEED 10,000 PSI.

5. Operate the pump to apply pressure to install the pivot bushing completely into the spring.

WARNING

TO PREVENT PERSONAL INJURY FROM POSSIBLE BREAKAGE UNDER PRESSURE, DO NOT STAND IN THE VICINITY OF THE TOOL WHILE THE PIVOT BUSHING IS BEING INSTALLED. IT IS ESPECIALLY IMPORTANT TO NOT STAND IN THE DIRECTION OF THE HYDRAULIC FORCE.

FIGURE 8-16

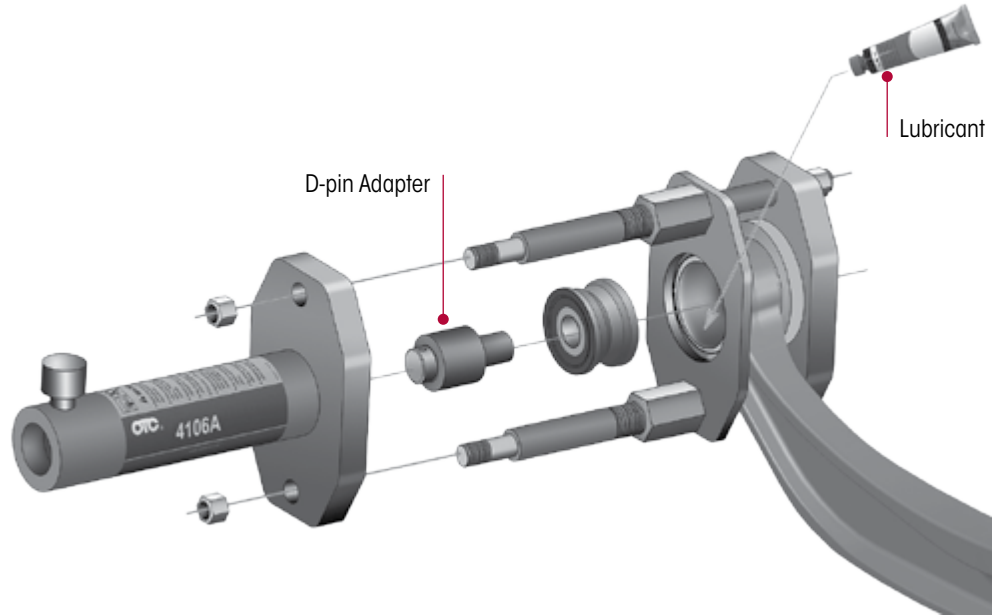

METHOD B – Using Tool No. 66086-203L

SERVICE HINT

Use QUIK-ALIGN Pivot Bushing Tool No. 66086-203L to help with the installation / removal of the QUIK-ALIGN pivot bushing for PRIMAAX EX suspensions. The tool allows the old bushing to be pushed out from the U-beam assembly into the receiving cylinder at the same time as installing the new bushing into the U-beam assembly.

WARNING

A TECHNICIAN USING A SERVICE PROCEDURE OR TOOL WHICH HAS NOT BEEN RECOMMENDED BY HENDRICKSON MUST FIRST SATISFY HIMSELF THAT NEITHER HIS SAFETY NOR THE VEHICLE'S SAFETY WILL BE JEOPARDIZED BY THE METHOD OR TOOL SELECTED. INDIVIDUALS DEVIATING IN ANY MANNER FROM THE INSTRUCTIONS PROVIDED WILL ASSUME ALL RISKS OF CONSEQUENTIAL PERSONAL INJURY OR DAMAGE TO EQUIPMENT INVOLVED.

NOTE

When replacing a pivot bushing it is recommended to replace both pivot bushings on the U-beam assembly.

To replace the QUIK-ALIGN pivot bushing you will need:

- A QUIK-ALIGN pivot bushing service tool (Part No. 66086-203L), see Figure 8-17
- ¾" Impact wrench (impact gun), some ½" impact wrenches may work

FIGURE 8-17

NOTE

Apply NLGI #2-EP chassis lubricant to each face of the thrust washers and to the drive screw that will engage through the receiving cylinder.

Apply P80 lubricant to the face of the lead-in flange and the outer diameter of NEW pivot bushing

**QUIK-ALIGN Pivot Bushing Tool
Part No. 66086-203**

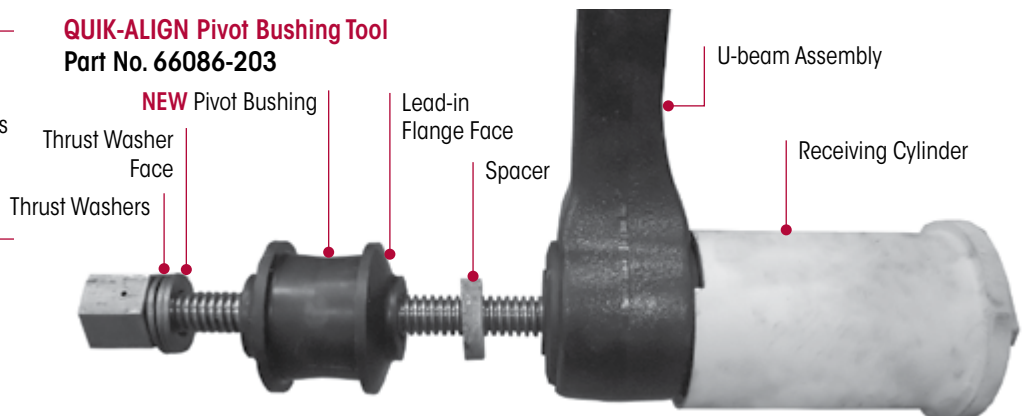

DISASSEMBLY

1. Remove the U-beam assembly from the vehicle per the U-beam Disassembly procedure in this Section.
2. After removal, place U-beam assembly on the floor or suitable work area.

ASSEMBLY
NOTE

The 66086-203L tool can be used to remove the old bushing first then install the new bushing, if bore inspection is needed.

1. Install the pivot bushing tool and the new pivot bushing as shown in Figure 8-17.
2. Remove any loose rubber or debris from the old bushing.
3. Apply NLGI #2-EP (Extreme Pressure) chassis lubricant to each face of the thrust washers and to the drive screw that will engage through the receiving cylinder.
4. Snug the threaded drive screw to hold the thrust washers, NEW pivot bushing, spacer, U-beam assembly with the old pivot bushing and the receiving cylinder in place, see Figure 8-18.

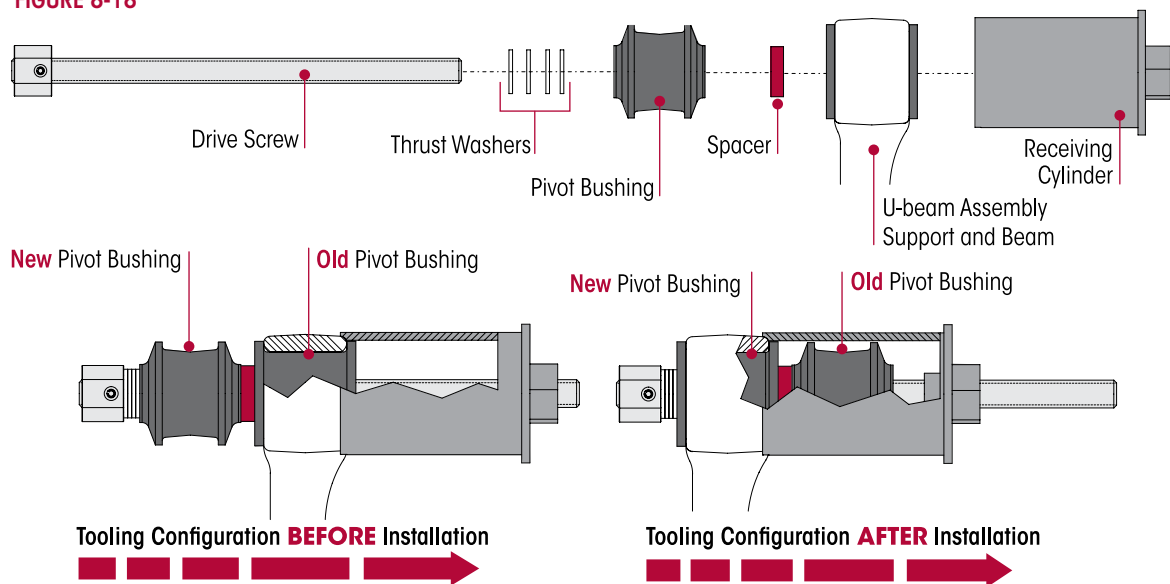
FIGURE 8-18

NOTE

DO NOT use petroleum or soap base lubricant, it can cause an adverse reaction with the bushing material, such as deterioration.

5. Apply P-80 lubricant to the face of the lead-in flange and the outer diameter of NEW pivot bushing, see Figure 8-17. P-80 lubricant is supplied in the QUIK-ALIGN Pivot Bushing Kits (Wheel End Kit No. 60961-720 or Axle Set Kit No. 60632-020).

SERVICE HINT

To center the pivot bushing within the end hub, it may be necessary to overshoot the desired final position. Then from opposite side, reverse the installation tool and press the pivot bushing again to center the bushing within the beam end hub.

6. Using a $\frac{3}{4}$ " impact wrench, rotate the drive screw in a continuous motion without stopping until the pivot bushing appears centered in the hub. The old bushing will fall into the receiving cylinder, see Figure 8-18.
7. Using the impact wrench rotate the drive screw in the opposite direction to remove tool.
8. Repeat Steps 1 through 6 for other side of the U-beam assembly.
9. Allow the lubricant **four hours** to dissipate before fully operating the vehicle.
10. Install the U-beam assembly per the U-beam Assembly procedure in this Section.

TOP PAD

DISASSEMBLY

1. Chock the front wheels.
2. Support the frame at ride height.
3. Disconnect the height control valve linkage assembly from the height control valve arm(s) by sliding the rubber grommet off the stud on the height control valve arm.

WARNING

PRIOR TO AND DURING DEFLATION AND INFLATION OF THE AIR SUSPENSION SYSTEM, ENSURE THAT ALL PERSONNEL AND EQUIPMENT ARE CLEAR FROM UNDER THE VEHICLE AND AROUND THE SERVICE AREA, FAILURE TO DO SO CAN CAUSE SERIOUS PERSONAL INJURY, DEATH, OR PROPERTY DAMAGE.

4. See additional Air Spring Cautions and Warnings in the Important Safety Notice Section of this publication prior to deflating or inflating the air system.

WARNING

SOME VEHICLE APPLICATIONS, SUCH AS VEHICLES EQUIPPED WITH OUTRIGGERS, RETAIN SOME AIR PRESSURE IN THE AIR SPRINGS AT ALL TIMES. PRIOR TO PERFORMING ANY MAINTENANCE, SERVICE, OR REPAIR OF THE SUSPENSION, VERIFY EACH AIR SPRING IS COMPLETELY DEFLATED. FAILURE TO DO SO COULD RESULT SERIOUS PROPERTY DAMAGE AND/OR SEVERE PERSONAL INJURY.

5. Lower the height control valve arm(s) to exhaust the air in the air springs and deflate the rear suspension.

SERVICE HINT

Note the quantity of shims removed to maintain the correct pinion angle of the axle at assembly. Refer to the Alignment & Adjustments Section of this publication.

6. Remove and discard the fasteners from the longitudinal torque rod to top pad joint. Remove the shims (if equipped), see Figure 8-19.

FIGURE 8-19

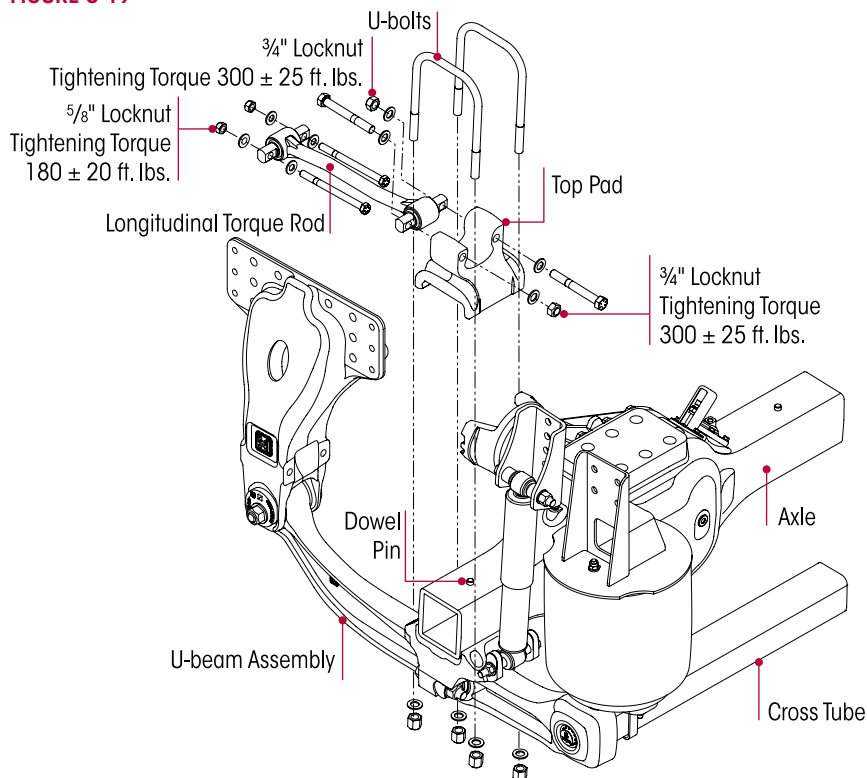

NOTE

Due to certain pinion angle configurations, the removal of the D-Pin bolts may be necessary to access the U-bolt locknuts.

7. Support the U-beam assembly with a floor jack that is equipped with a 4" contact plate.
8. Remove and discard the U-bolt fasteners from the clamp group.

9. Remove the top pad.
10. Inspect the top pad and the axle housing for any cracks or damage. Replace if necessary.

ASSEMBLY

1. Install the top pad on the top of the axle engaging the dowel pin. Care should be taken to ensure the taller ear of the top pad is mounted to the inboard side of the suspension. The top pad varies with different models and may appear different, see Figure 8-20.
2. Install the new U-bolts, washers, and locknuts.

NOTE

Current Hendrickson Truck Suspension Systems U-bolt locknuts for the PRIMAAX EX suspension are 3/4"-16 Grade C and are phosphate and oil coated.

3. Verify that the U-bolts are seated properly in the top pad channels, see Figure 8-19.
4. Tighten the U-bolt locknuts evenly in 50 foot pound increments in the proper pattern to achieve uniform bolt tension, see Figure 8-21.
5. Rap the top of the U-bolts with a dead blow mallet, and retighten to the proper torque. **DO NOT** exceed specified torque on U-bolt locknuts. Tighten the 3/4" locknuts to 375 ± 25 foot pounds torque.
6. Tighten the D-Pin fasteners to 300 ± 25 foot pounds torque if loosened or removed during disassembly, see Figure 8-22.

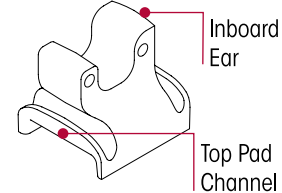
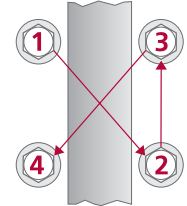
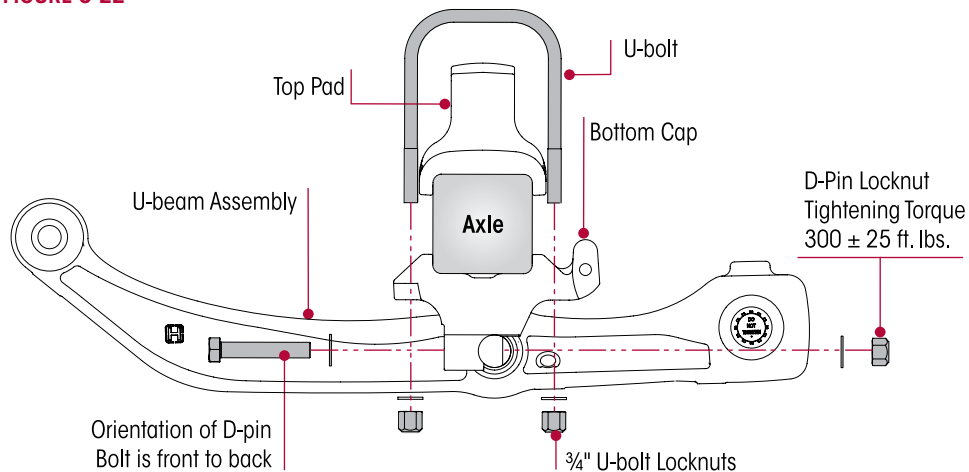
FIGURE 8-20

FIGURE 8-21

FIGURE 8-22

7. Remove the support from the support beam assembly.
8. Install the fasteners on the longitudinal torque rod, **DO NOT** tighten at this time.
9. See additional Air Spring Cautions and Warnings in the Important Safety Notice Section of this publication prior to deflating or inflating the air system.
10. Connect the height control valve linkage rod(s) to the height control valve arm(s) to inflate the suspension.
11. Remove the frame stands.

NOTE

It is mandatory to have the vehicle at proper ride height prior to tightening the 7/8" top pad through bolt locknut to torque specifications.

12. Tighten the longitudinal torque rod fasteners to the required specification, see the Torque Specifications Section of this publication.
13. Remove the wheel chocks.

BOTTOM CAP

NOTE

It is not necessary to loosen the QUIK-ALIGN connection to service the bottom cap therefore alignment is preserved during service. If the QUIK-ALIGN connection is loosened during service, alignment is required after service is completed.

DISASSEMBLY

1. Chock the wheels of the axle.
2. Raise the frame of the vehicle to remove the load from the suspension. Support the frame.
3. Raise and support the axle being serviced. Remove the tires.
4. Disconnect the height control linkage assembly from the height control valve arm by sliding the rubber grommet off the height control valve arm's stud.

WARNING

PRIOR TO AND DURING DEFLATION AND INFLATION OF THE AIR SUSPENSION SYSTEM, ENSURE THAT ALL PERSONNEL AND EQUIPMENT ARE CLEAR FROM UNDER THE VEHICLE AND AROUND THE SERVICE AREA, FAILURE TO DO SO CAN CAUSE SERIOUS PERSONAL INJURY, DEATH, OR PROPERTY DAMAGE.

5. See additional Air Spring Cautions and Warnings in the Important Safety Notice Section of this publication prior to deflating or inflating the air system.

WARNING

SOME VEHICLE APPLICATIONS, SUCH AS VEHICLES EQUIPPED WITH OUTRIGGERS, RETAIN SOME AIR PRESSURE IN THE AIR SPRINGS AT ALL TIMES. PRIOR TO PERFORMING ANY MAINTENANCE, SERVICE, OR REPAIR OF THE SUSPENSION, VERIFY EACH AIR SPRING IS COMPLETELY DEFLATED. FAILURE TO DO SO COULD RESULT SERIOUS PROPERTY DAMAGE AND/OR SEVERE PERSONAL INJURY.

6. Lower the height control valve arm(s) to exhaust the air in the air springs and deflate the rear suspension.
7. Clean and lubricate the lower mounting fasteners of the air springs with penetrating oil. This will help prevent the air spring mounting studs from breaking during the removal process.

8. Remove the lower mounting fasteners from the air springs using **HAND TOOLS** only, see Figure 8-23.

WARNING

IT IS MANDATORY TO USE A FLOOR JACK EQUIPPED WITH A FOUR INCH CONTACT PLATE TO SUPPORT THE U-BEAM ASSEMBLY AT THE CROSS TUBE TO FACILITATE SAFE LOWERING AND RAISING OF THE U-BEAM ASSEMBLY. DO NOT USE A BOTTLE JACK. A BOTTLE JACK DOES NOT HAVE ENOUGH CONTACT AREA AND CAN BE UNSTABLE. FAILURE TO DO SO CAN CAUSE COMPONENT DAMAGE OR RESULT IN PERSONAL INJURY.

9. Support the U-beam assembly at the cross tube with a floor jack that is equipped with a four inch contact plate.

WARNING

THE WEIGHT OF THE U-BEAM ASSEMBLY IS APPROXIMATELY 225 POUNDS. CARE SHOULD BE TAKEN AT REMOVAL AND INSTALLATION TO PREVENT PERSONAL INJURY OR DAMAGE TO COMPONENTS.

10. Remove the D-Pin fasteners from both sides of the support beam.

11. Raise the front of the differential to facilitate removal of the D-Pins from the bottom caps.

FIGURE 8-23

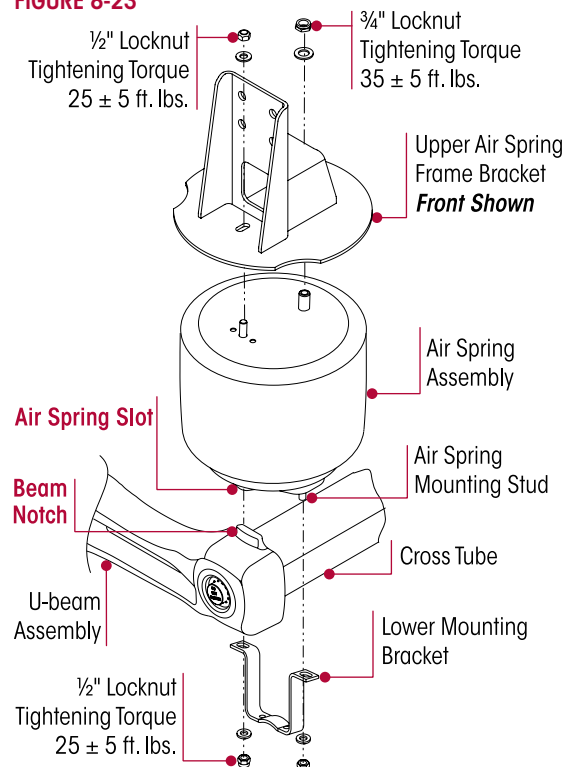

12. Lower the floor jack to pivot the U-beam assembly down from the bottom caps.
13. Remove the lower shock absorber mounting fasteners. Pivot the lower shock mount out of the bottom cap.
14. Remove the U-bolt fasteners from the clamp group and discard.
15. Remove the bottom cap and inspect for damage or wear. Replace as necessary.

ASSEMBLY

1. Install the top pad (if removed) on the top of the axle engaging the dowel pin. Care should be taken to ensure the taller ear of the top pad is mounted to the inboard side of the suspension, see Figure 8-24.
2. Install the bottom cap on the axle in the proper direction, with the lower shock mounting holes facing the rear of the vehicle.
3. Install the new U-bolts. Verify that the U-bolts are seated properly in the top pad channels and through the bottom cap.

FIGURE 8-24

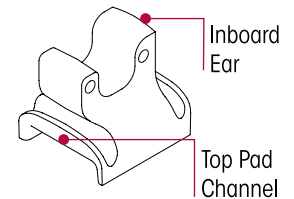

NOTE

Current Hendrickson Truck Suspension Systems U-bolt locknuts for the PRIMAAX EX suspension are 3/4" -16 Grade C and are phosphate and oil coated.



4. Install the U-bolt 3/4" washers and the locknuts.

PRIOR TO TIGHTENING THE U-BOLTS TO THE FINAL TORQUE, ENSURE THE U-BEAM ASSEMBLY AND THE BOTTOM CAP ASSEMBLY ARE CENTERED ON THE AXLE ($A = B \pm 1/8"$). SEE FIGURE 8-25. FAILURE TO DO SO COULD CAUSE PREMATURE COMPONENT WEAR OR CAUSE UNEVEN LOAD DISTRIBUTION.

5. Center the U-beam assembly, and the bottom cap assembly on the axle ($A = B \pm 1/8"$), see Figure 8-25.

FIGURE 8-25 15½" Ride Height

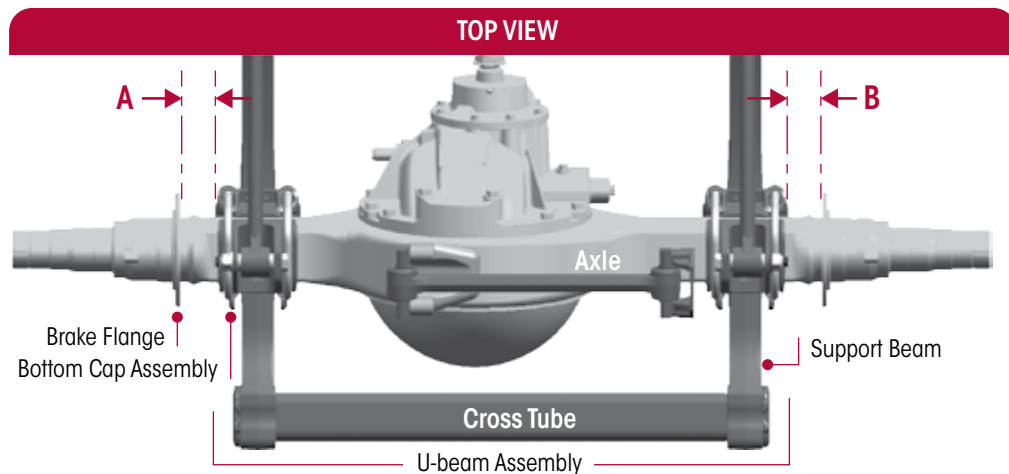

SERVICE HINT

It may be necessary to raise the front of the differential to allow the D-Pins to engage the bottom cap.

6. Raise the U-beam assembly until the D-Pins engage in the bottom cap.
7. Install the D-Pin fasteners with the bolt heads on the forward side of the bottom cap, see Figure 8-22.
8. Lower the front differential to allow the full engagement of the D-Pins into the bottom caps.
9. Prior to tightening the D-pin fasteners, verify the bottom cap is centered over the support beam.
10. Tighten the D-Pin fasteners to $\boxed{300} \pm 25$ foot pounds torque.

11. Tighten the U-bolt locknuts evenly in 50 foot pound increments in the proper pattern to achieve uniform bolt tension, see Figure 8-26.
12. Rap the top of the U-bolts with a dead blow mallet, and retighten to the proper torque. **DO NOT** exceed the specified tightening torque specified on the U-bolt locknuts. Tighten the 3/4" locknuts to \mathbb{R} 375 \pm 25 foot pounds torque.
13. Pivot the shock back into the lower shock mount and install the lower shock absorber mounting fasteners. Tighten the 5/8" locknuts to \mathbb{R} 213 \pm 12 foot pounds torque.
14. Install the air spring between the frame and the cross tube, see Figure 8-23. Ensure the **air spring slot** in the bottom of the air spring engages the **beam notch** on the top of the support beam.
15. Install the lower air spring mounting bracket around the cross tube, engaging the mounting air spring studs, see Figure 8-23.
16. Install the lower mounting fasteners and tighten to \mathbb{R} 25 \pm 5 foot pounds torque.
17. Install the tires (if removed).
18. Remove the jack stands and lower the frame of vehicle.
19. See additional Air Spring Cautions and Warnings in the Important Safety Notice Section of this publication prior to deflating or inflating the air system.
20. Connect the height control valve linkage(s) to the height control valve arm(s) to inflate the suspension.
21. Remove the wheel chocks.

FIGURE 8-26

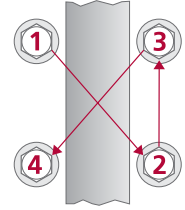

AXLE STOPS

DISASSEMBLY

1. Chock the wheels.
2. Remove the fasteners connecting the axle stop to the frame.
3. Remove the axle stop.
4. Inspect the frame rail mounting surfaces for any cracks or damage.

ASSEMBLY

1. Install the axle stop on the frame.
2. Install new mounting fasteners.
3. Tighten axle stop fasteners to the vehicle manufacturer's torque specifications.
4. Install any items removed
5. Remove the wheel chocks.

FRAME HANGER

WARNING

THIS PROCEDURE TO REPLACE A FRAME HANGER, IS DONE WITH THE REMAINING FRAME HANGERS CONNECTED TO THE FRAME AND IT IS ALSO NECESSARY THAT THE SUPPORT BEAMS AND THE LONGITUDINAL TORQUE RODS ARE ATTACHED TO THE REMAINING FRAME HANGERS. FAILURE TO DO SO COULD CAUSE THE AXLE TO SHIFT RESULTING IN POSSIBLE DAMAGE TO COMPONENTS OR PERSONAL INJURY.

SERVICE HINT

Increasing the pinion angle may facilitate the disassembly/assembly of the frame hanger. To increase the pinion angle place a floor jack under the axle pinion and raise slightly. This will increase the pinion angle slightly easing disassembly/assembly.

DISASSEMBLY

1. Chock the front wheels.
2. Support the frame.
3. Disconnect the height control valve arm(s) from the rubber grommet.

WARNING

PRIOR TO AND DURING DEFLATION AND INFLATION OF THE AIR SUSPENSION SYSTEM, ENSURE THAT ALL PERSONNEL AND EQUIPMENT ARE CLEAR FROM UNDER THE VEHICLE AND AROUND THE SERVICE AREA, FAILURE TO DO SO CAN CAUSE SERIOUS PERSONAL INJURY, DEATH, OR PROPERTY DAMAGE.

4. See additional Air Spring Cautions and Warnings in the Important Safety Notice Section of this publication prior to deflating or inflating the air system.

WARNING

SOME VEHICLE APPLICATIONS, SUCH AS VEHICLES EQUIPPED WITH OUTRIGGERS, RETAIN SOME AIR PRESSURE IN THE AIR SPRINGS AT ALL TIMES. PRIOR TO PERFORMING ANY MAINTENANCE, SERVICE, OR REPAIR OF THE SUSPENSION, VERIFY EACH AIR SPRING IS COMPLETELY DEFLATED. FAILURE TO DO SO COULD RESULT SERIOUS PROPERTY DAMAGE AND/OR SEVERE PERSONAL INJURY.

5. Lower the height control valve arm(s) to exhaust the air in the air springs and deflate the rear suspension.

SERVICE HINT

Each frame hanger will have a pair of QUIK-ALIGN collars. Any eccentric (with the square drive feature) QUIK-ALIGN collar should be mounted on the outboard side of the frame hanger. Axle thrust angles can only be corrected on frame hangers equipped with eccentric QUIK-ALIGN collars.

SERVICE HINT

Mark the position of the QUIK-ALIGN square drive in relationship to the frame hanger with a paint stick prior to loosening the QUIK-ALIGN connection. This will facilitate the axle alignment process after the repair is complete.

6. Remove the QUIK-ALIGN fasteners and collars, and note the orientation of the fasteners, see Figure 8-27. Discard the fasteners. The collars may be reused if they are not damaged.

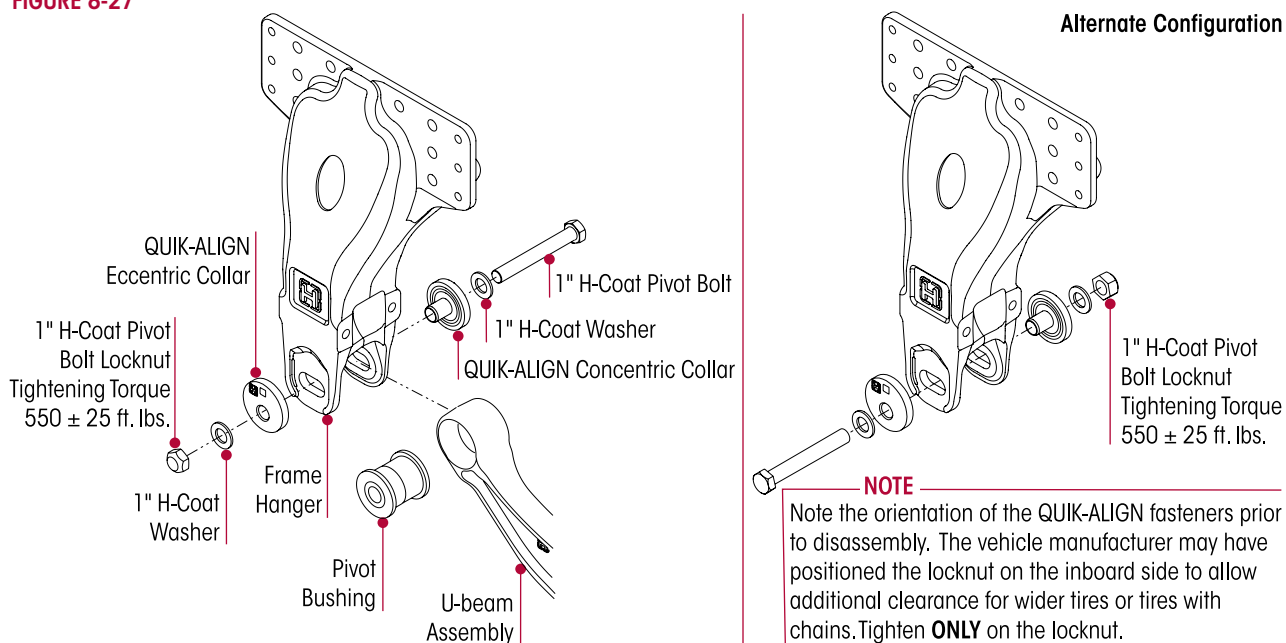
FIGURE 8-27

SERVICE HINT

Note the quantity of longitudinal shims removed to maintain the correct pinion angle of the axle at assembly. See Alignment & Adjustments Section of this publication.

7. Remove the fasteners and shim (if equipped) that attach the longitudinal torque rod to the frame hanger.



8. Remove the fasteners that attach the frame hanger to the vehicle per vehicle manufacturer's specifications.
9. Remove the frame hanger.
10. Inspect mounting surface for any damage or wear.
11. Inspect the QUIK-ALIGN pivot bushing and torque rod bushings for wear or damage, replace as necessary.

ASSEMBLY

1. Slide the new frame hanger over the support beam QUIK-ALIGN bushing.
2. Install the new fasteners that attach the frame hanger to the vehicle and tighten per the vehicle manufacturer's specifications.

WARNING

DISCARD USED QUIK-ALIGN FASTENERS. ALWAYS USE NEW QUIK-ALIGN FASTENERS TO COMPLETE A REPAIR. FAILURE TO DO SO COULD RESULT IN FAILURE OF THE PART, OR MATING COMPONENTS, ADVERSE VEHICLE HANDLING, PERSONAL INJURY, OR PROPERTY DAMAGE.

DO NOT ASSEMBLE QUIK-ALIGN JOINT WITHOUT THE PROPER FASTENERS. USE ONLY H-COATED FASTENERS TO SUSTAIN PROPER CLAMP FORCE. FAILURE TO DO SO CAN CAUSE ADVERSE VEHICLE HANDLING, PROPERTY DAMAGE OR PERSONAL INJURY AND VOID WARRANTY. ENSURE THAT THE QUIK-ALIGN FASTENER'S TORQUE VALUES ARE SUSTAINED AS RECOMMENDED IN THE TORQUE SPECIFICATIONS SECTION OF THIS PUBLICATION. FAILURE TO DO SO CAN CAUSE ADVERSE VEHICLE HANDLING RESULTING IN PERSONAL INJURY OR PROPERTY DAMAGE. FOLLOW VEHICLE MANUFACTURER'S FASTENER ORIENTATION WHEN PERFORMING ANY MAINTENANCE, SERVICE OR REPAIR.

NOTE

Use a new QUIK-ALIGN pivot bolt kit (see the Parts List Section of this publication) for any axle alignment or disassembly of the QUIK-ALIGN connection. This will help ensure that the proper clamp load is applied to the connection and help prevent the joint to slip in service.

3. Install the QUIK-ALIGN collars and the new mounting hardware that attach the support beam to the frame hanger, see Figure 8-27. Verify that the nose of each QUIK-ALIGN collar is installed correctly into pivot bushing sleeve, and the flanged side is flat against the frame hanger face within the alignment guides. Snug QUIK-ALIGN locknuts to 50-100 foot pounds torque, **DO NOT** tighten at this time.
4. Install the torque rod mounting fasteners and reinstall any shims that were removed during disassembly. Tighten the fasteners to the proper specification, see Torque Specification Section of this publication per model designation.
5. See additional Air Spring Cautions and Warnings in the Important Safety Notice Section of this publication prior to deflating or inflating the air system.
6. Connect the height control valve linkage rod(s) to the height control valve arm(s) to inflate the suspension properly.
7. Remove frame supports(s).
8. Verify that the axle is in proper alignment, see Alignment & Adjustments Section of this publication.

NOTE

It is mandatory to have the vehicle at proper ride height prior to tightening the 1.0" QUIK-ALIGN locknuts to torque specifications.

9. After the correct alignment of the axle is verified tighten the 1.0" QUIK-ALIGN locknuts to  550 ± 25 foot pounds torque.
10. Verify the correct pinion angle on the axle per original equipment manufacturer's specifications. Adjust as necessary per the Alignment & Adjustments Section of this publication.
11. Remove the chocks from the front wheels.



SECTION 9 Plumbing Diagram

HENDRICKSON RECOMMENDED PLUMBING DIAGRAM

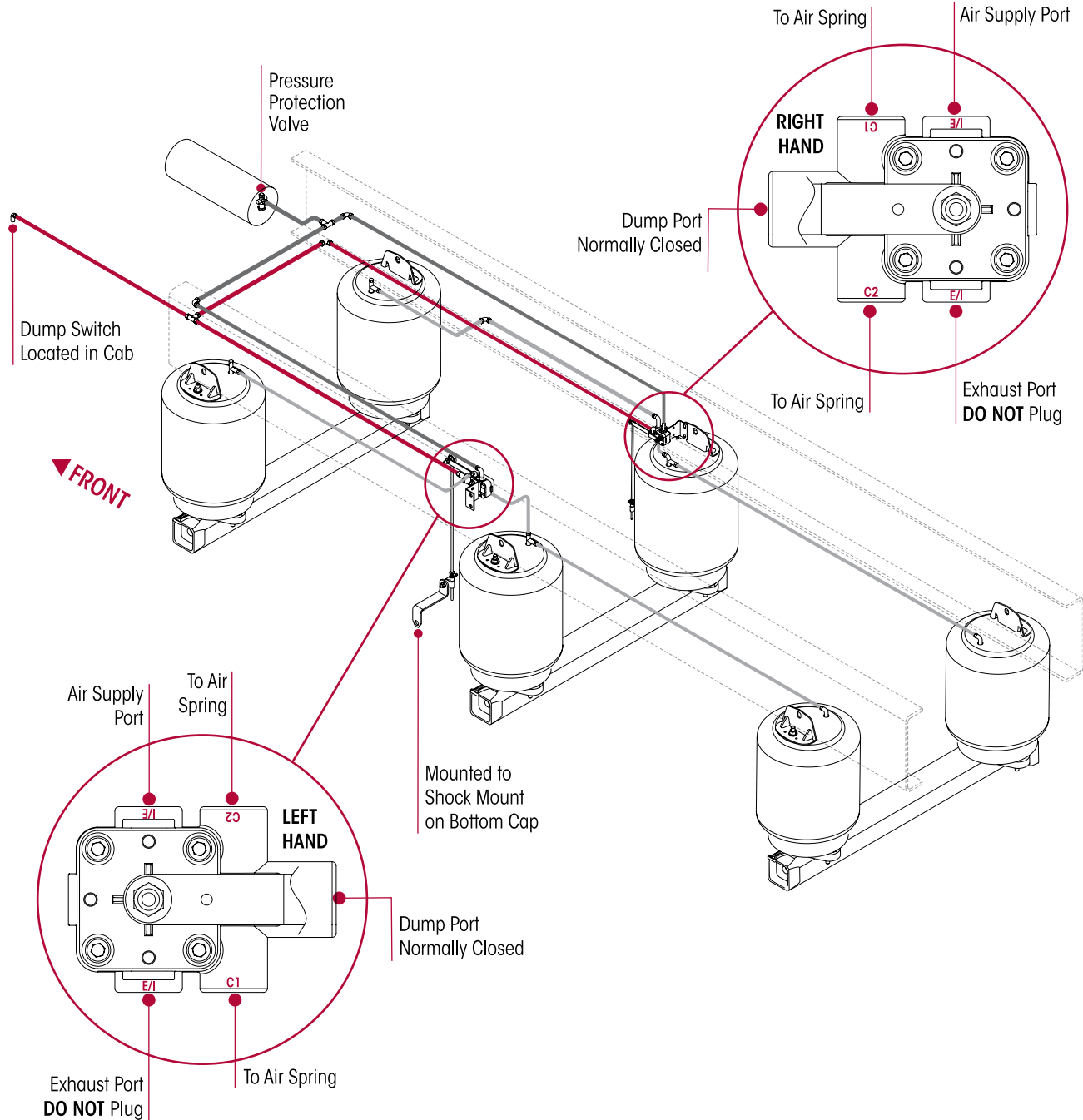



SECTION 10 Torque Specifications

HENDRICKSON RECOMMENDED
TORQUE VALUES PROVIDED IN FOOT POUNDS

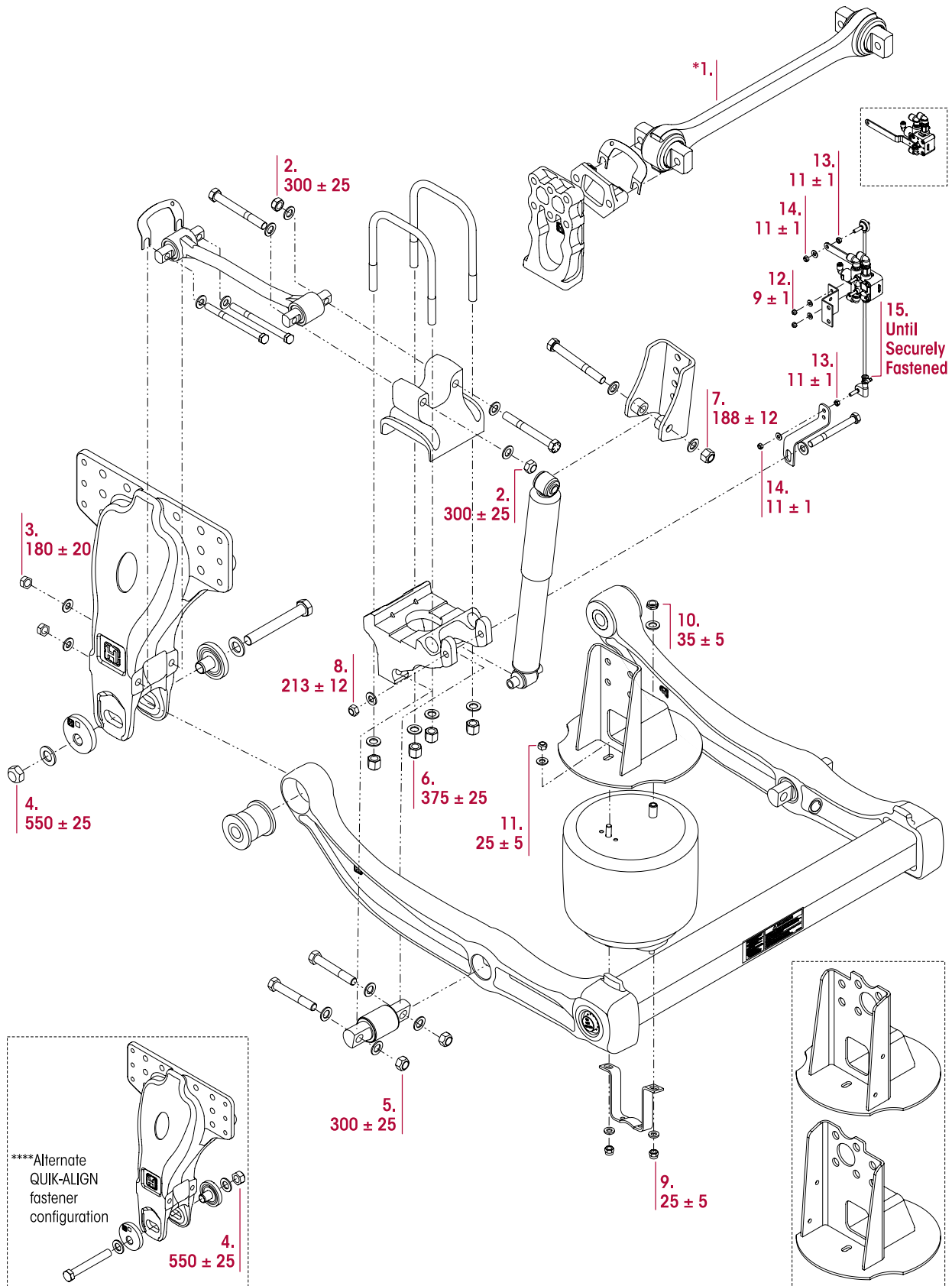

****Alternate
QUIK-ALIGN
fastener
configuration

4.
 550 ± 25



PRIMAAX EX for Mack HDT Vehicles

HENDRICKSON RECOMMENDED TORQUE SPECIFICATIONS

NO	COMPONENT	QUANTITY	SIZE	*TORQUE VALUE (IN FOOT POUNDS)
	Frame fasteners are furnished and installed by the vehicle manufacturer. Vehicle manufacturer may use an equivalent HUCK fastener at frame mount. See vehicle manufacturer for torque requirements.			
1	Transverse TRAAX ROD			*
2	Longitudinal Torque Rod to Top Pad	12	¾"-16 UNF	**300 ± 25
3	Longitudinal Torque Rod to Frame Hanger	12	⅝"-11 UNC	180 ± 20
4	U-beam Assembly to QUIK-ALIGN Bushing	6	1"-8 UNC	**550 ± 25
5	U-beam Assembly to Center D-pin Bushing	12	⅞"-14 UNF	300 ± 25
6	U-bolt Locknuts	12	¾"-16 UNF	**375 ± 25
7	Upper Shock Absorber Locknuts	6	¾"-10 UNC	188 ± 12
8	Lower Shock Absorber Locknuts	6	⅝"-11 UNC	213 ± 25
9	Air Spring Assembly to Lower Air Spring Mounting Bracket	18	½"-13 UNC	25 ± 5
10	Air Spring Assembly to Upper Air Spring Mounting Bracket	6	¾"-16 UNF	35 ± 5
11	Upper Air Spring Assembly	18	½"-13 UNC	25 ± 5
12	Height Control Valve to Height Control Valve Frame Bracket	6	¼"-20 UNC	9 ± 1
13	Height Control Valve Linkage Jam Nut	6	⅝"-18 UNC	11 ± 1
14	Height Control Valve Linkage to HCV and HCV Linkage Bracket	6	⅝"-18 UNC	11 ± 1
15	Height Control Valve Linkage Clamp	6		Until Securely Fastened

NOTE: * Torque values shown apply only if Hendrickson supplied fasteners are used. If non Hendrickson fasteners are used, follow the torque specification listed in vehicle manufacturer's service manual.

** See Preventive Maintenance Section of this publication for re-torque intervals.



SECTION 11

Troubleshooting Guide

TROUBLESHOOTING GUIDE		
CONDITION	POSSIBLE CAUSE	CORRECTION
Suspension has harsh or bumpy ride	Air spring not inflated to specification or damaged	Repair air system and check ride height. See Ride Height Adjustment in the Alignment & Adjustments Section.
	Ride height set incorrectly	Adjust ride height to proper setting. See Ride Height Adjustment in the Alignment & Adjustments Section.
	Suspension is overloaded	Redistribute load to correct weight.
	Broken support beam	Replace broken U-beam assembly.
Irregular tire wear	Incorrect tire inflation pressure	Correct tire pressure per vehicle manufacturer and tire manufacturer specifications.
	Incorrect alignment	Correct the alignment. Refer to the Alignment & Adjustments Section.
	Worn QUIK-ALIGN bushing	Replace QUIK-ALIGN bushing.
	Loose QUIK-ALIGN attachment	Replace QUIK-ALIGN connection, and check vehicle alignment. Adjust if necessary. Check frame hanger for wear around QUIK-ALIGN plates and replace if necessary.
Excessive driveline vibration	Worn torque rod bushings	Replace torque rod bushings as necessary.
	Incorrect pinion angle(s)	Adjust pinion angle(s), refer to the vehicle manufacturer for specifications.
	Loose QUIK-ALIGN attachment	Replace QUIK-ALIGN connection, and check vehicle alignment. Adjust if necessary. Check frame hanger for wear around QUIK-ALIGN plates and replace if necessary.
	Ride height set incorrectly	Adjust ride height to proper setting. See Ride Height Adjustment in the Alignment & Adjustments Section.
Suspension is noisy	Broken support beam	Replace U-beam assembly.
	Loose QUIK-ALIGN attachment	Replace QUIK-ALIGN connection, and check vehicle alignment. Adjust if necessary. Check frame hanger for wear around QUIK-ALIGN plates and replace if necessary.
	Loose U-bolts	Tighten U-bolts to specifications, see Preventive Maintenance Section.
	Loose end caps (if equipped)	Inspect end caps and the support beam to cross tube connection for damage. Repair as necessary, re-torque end cap to specification, see Torque Specifications Section.
Vehicle bouncing excessively	Worn bushings	Replace bushings as necessary.
	Damaged or leaking shock absorber	Replace shock absorber.
	Ride height set incorrectly	Adjust ride height to proper setting. See Ride Height Adjustment in the Alignment & Adjustments Section.



TROUBLESHOOTING GUIDE (CONT.)

CONDITION	POSSIBLE CAUSE	CORRECTION
Vehicle leaning	Air spring not inflated to specification or damaged	Repair air system and check ride height. See Ride Height Adjustment in the Alignment & Adjustments Section in this publication.
	Load not centered	Redistribute the load.
	Frame twisted	Straighten the frame per vehicle manufacturer's guidelines.
	Broken support beam	Replace broken U-beam assembly.
	Axle housing bent or broken	Replace axle housing per vehicle manufacturer guidelines and align vehicle.
	Loose U-bolts	Tighten U-bolts to specifications, see Preventive Maintenance Section.
	Front suspension	Inspect and repair front suspension.
Suspension will not reach ride height	Suspension is overloaded	Redistribute load to correct weight.
	Air Spring leaking or damaged	Replace air spring.
	Leak in air system	Inspect air fittings, see Air Fitting Inspection in the Preventive Maintenance Section of this publication. If necessary, repair air system and check ride height. See Ride Height Adjustment in the Alignment & Adjustments Section of this publication.
	Air line obstructed or improperly connected	Repair air system and check ride height. See Ride Height Adjustment in the Alignment & Adjustments Section.
	HCV dump port activated	Check HCV dump port for proper connection and function
Air springs deflate when parked	Leak in air system	Inspect air fittings, see Air Fitting Inspection in the Preventive Maintenance Section of this publication. If necessary, repair air system and check ride height. See Ride Height Adjustment in the Alignment & Adjustments Section of this publication.
	Malfunctioning Height Control Valve	See test procedure in Preventive Maintenance Section, replace height control valve as necessary.
Excessive frame slope	Ride height set incorrectly	Adjust the ride height to proper setting. See Ride Height Adjustment in the Alignment & Adjustments Section of this publication.
	Suspension is overloaded	Redistribute load to correct weight

Actual product performance may vary depending upon vehicle configuration, operation, service and other factors.
All applications must comply with applicable Hendrickson specifications and must be approved by the respective vehicle manufacturer with the vehicle in its original, as-built configuration.
Contact Hendrickson for additional details regarding specifications, applications, capacities, and operation, service and maintenance instructions.

*Call your truck dealer or Hendrickson at **1.866.755.5968** (toll-free) or **1.630.910.2800** for additional information.*



www.hendrickson-intl.com

TRUCK COMMERCIAL VEHICLE SYSTEMS
800 South Frontage Road
Woodridge, IL 60517-4904 USA
1.866.755.5968 (Toll-free U.S. and Canada)
1.630.910.2800 (Outside U.S. and Canada)
Fax 1.630.910.2899

17730-329 Rev A 06-20

© 2020 Hendrickson USA, L.L.C. All Rights Reserved. All trademarks shown are owned by Hendrickson USA, L.L.C., or one of the affiliates, in one or more countries.
Information contained in this literature was accurate at the time of publication. Product changes may have been made after the copyright date that are not reflected.

Printed in United States of America