

For complete instructions, refer to Hendrickson literature number **L496 TRAILER SUSPENSION SYSTEMS SERVICE WHEEL-END HUB MAINTENANCE** procedures before referencing this document.

## CHECKING ENDPLAY

**NOTE:** If extended wheel-end service (HXL), refer to applicable literature and CONTACTING HENDRICKSON on page 4 of L496 TRAILER SUSPENSION SYSTEMS SERVICE WHEEL-END HUB MAINTENANCE before continuing.

This procedure should be performed:

- After CONTACTING HENDRICKSON Technical Services for guidance relative to suspected wheel-end play movement, before removing the hubcap
- After installing hub and when instructed by spindle nut installation procedure

1. If not already done so:

- Perform PREPARING TRAILER FOR SERVICE on page 5 of L496 WHEEL-END HUB MAINTENANCE.
- Remove** wheel (tire and rims).
- Disengage** brakes.
- If drum brake, **remove** drum (recommended). If ADB, **remove** brake pads per manufacturer's recommended procedures.
- If oil lubricated, **drain** oil from wheel-end (do not reuse).
- Remove** hubcap and discard gasket.

**IMPORTANT:** End play can be checked with drum brake installed or removed (preferred). If installed, **ensure all brake drum wheel fasteners are installed and tightened to manufacturer specifications before** checking endplay.

2. **Ensure** hub hubcap mounting surface and end of spindle are **clean and totally free of any burrs or debris**.

3. **Rotate** hub at least 5 revolutions to ensure bearings are fully seated.

**NOTE:** The hub **MUST** be rotated before performing end play measurement. Rotation works the rollers into their fully seated positions against the bearing cone shoulder. **Failure to rotate hub could result in a false end play reading.**

4. **Attach dial indicator** (Table 2 on page 6 of L496 WHEEL-END HUB MAINTENANCE) with magnetic base to flat surface at end of spindle as shown below.

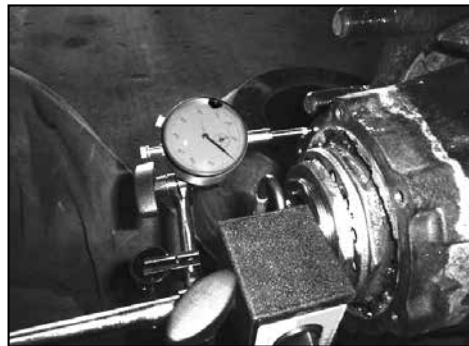

5. **Position dial indicator** so its pointer line of action is parallel to spindle axis and touches the hubcap mounting surface on the hub. Ensure the plunger contacts the hub in an area that is smooth and fully machined. Any regions with scratches, gauges, or non-cleanup should be avoided.

6. **Check** indicator for free movement in both directions. Lightly **push and pull** on indicator arm to verify plunger is free to move at least 0.005 in. each direction. If indicator bottoms out, readjust until its free to move 0.005 in. both directions.

7. **Zero** indicator.

8. **Grasp** hub flange as shown below, and **push** the hub inward **while rotating** the hub slightly in both directions (15-30° between two holes) until the dial indicator reading remains constant. **Record** reading.

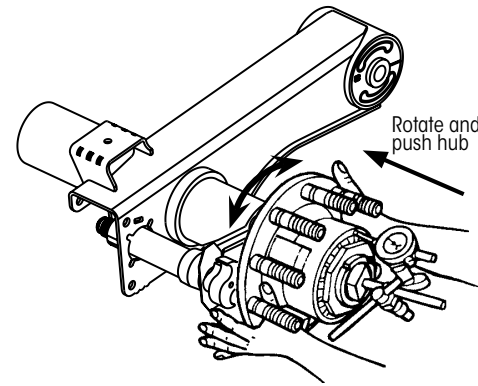

9. While still grasping the hub as shown below, **pull** hub outward **while rotating** hub slightly in both directions (15-30° between two holes) until the dial indicator remains constant. **Record** reading.

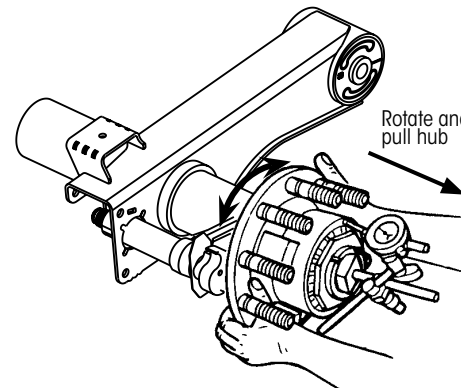

10. End play is the total movement of the indicator. **Calculate** the difference between recorded values of Step 8 and Step 9 to determine endplay. **Record** value.

**IMPORTANT:** End play should be between 0.001 in. (0.0254mm) and 0.005" (0.127mm). If subsequent readings are necessary, the hub must be rotated at least 5 revolutions to reset the bearings (refer to Step 3).

A. **If checking after spindle nut installation**, return to:

SPINDLE NUT SYSTEM	RETURN TO
<b>STANDARD THREE- OR FOUR- PIECE SPINDLE NUT ASSEMBLY</b>	Step 10 on page 15 of <u>L496 WHEEL- END HUB MAINTENANCE</u> .
<b>CASTLE SPINDLE NUT ASSEMBLY</b>	Step 7 on page 17 of <u>L496 WHEEL- END HUB MAINTENANCE</u> .
<b>STEMCO PRO-TORQUE® nut</b>	Refer to manufacturer's manual for installation procedures.
<b>PRECISION240® / PRECISION320®</b>	Refer to T72002, T72006, T72007 & T71005

B. If the end play is **within** specification, no bearing adjustment is necessary. Continue to next step.

C. If end play is **greater than 0.005 in.** (0.0254mm), tighten spindle nut (STANDARD THREE- OR FOUR- PIECE SPINDLE NUT ASSEMBLY on page 15 of L496 WHEEL- END HUB MAINTENANCE) or refer to CONTACTING HENDRICKSON on page 4 of L496 WHEEL- END HUB MAINTENANCE.

**IMPORTANT:** If end play is not within specifications, **DO NOT** place suspension back into service without correcting the problem.

11. Check to **ensure**, for 3-piece nut system (Figure 15 on page 15 of L496 WHEEL- END HUB MAINTENANCE):

- Inner adjusting nut is secure.
- Lock washer and tang are properly seated.
- Outer jam nut and retaining set screw are securely in place.

12. If not already done so, perform CHECKING FOR SEAL LEAKS on page 7 of L496 WHEEL- END HUB MAINTENANCE.

13. **Go to** INSTALL HUBCAP on page 18 of L496 WHEEL- END HUB MAINTENANCE.

www.hendrickson-intl.com  
**HENDRICKSON TRAILER COMMERCIAL VEHICLE SYSTEMS**  
 2070 Industrial Place SE  
 Canton, OH 44707-2641 USA