

**TORQUE SPECIFICATIONS**

DESCRIPTION	SIZE	TORQUE (FT-LB)
AIR SPRING NUT, AIR INLET STUD	3/4-16	45-55
AIR SPRING MOUNTING BOLTS	3/8-16	25-35
SIDE MOUNTING PREVAILING TORQUE NUTS	1/2-13	75-85
FRONT MOUNTING PREVAILING TORQUE NUT	5/8-11	170-210
BRAKE CHAMBER MOUNTING NUTS	5/8-11	100-110

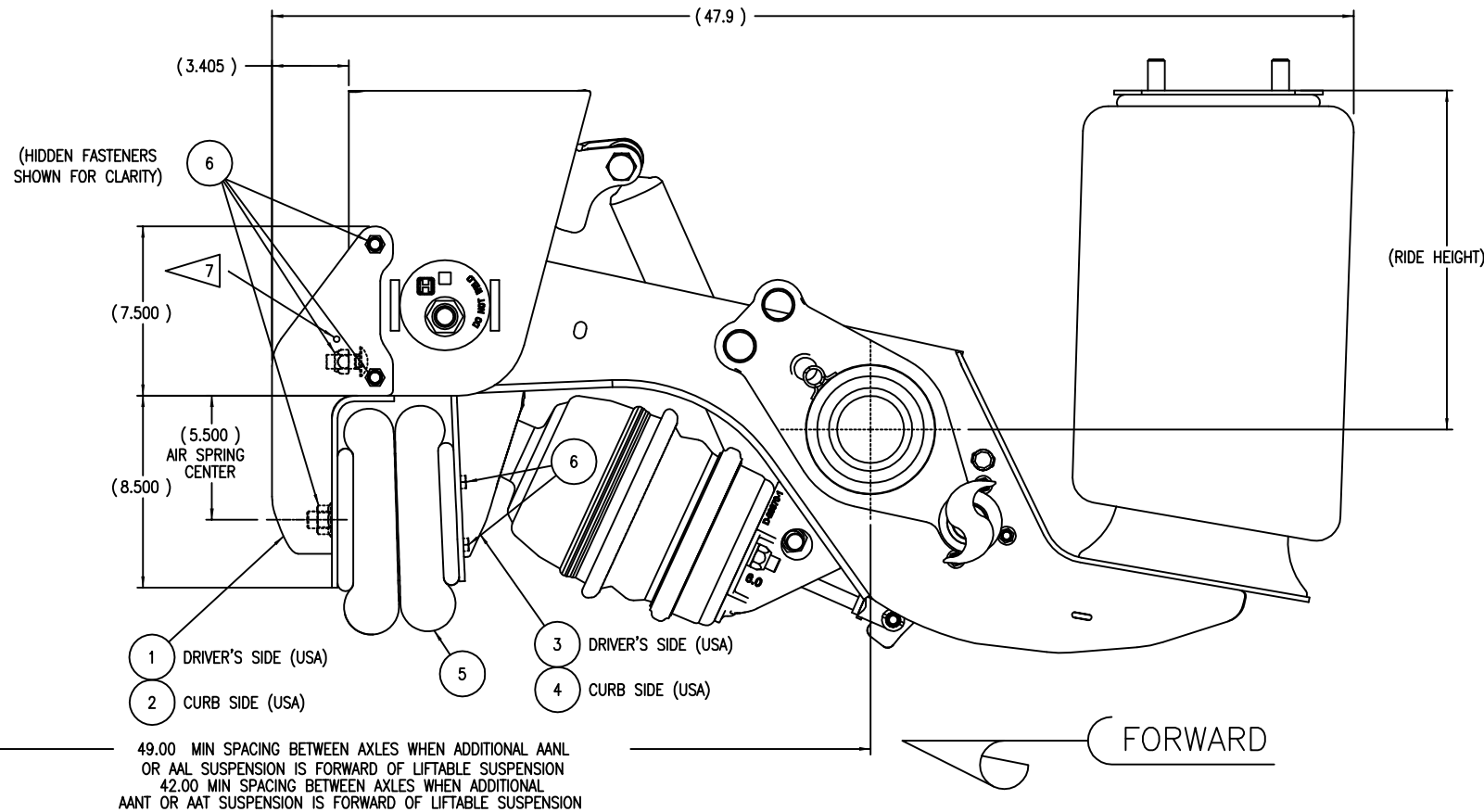

ITEM	PART NUMBER	DESCRIPTION	QTY.	UBL -005	UBL -005GV
1	C-30293-1C	FRONT BRACKET ASSEMBLY	1	8	8
1	C-30293-1GV	FRONT BRACKET ASSEMBLY	-	-	1
2	C-30293-2C	FRONT BRACKET ASSEMBLY	1	-	-
2	C-30293-2GV	FRONT BRACKET ASSEMBLY	-	-	1
3	C-30209-1C	REAR BRACKET ASSEMBLY	1	1	1
4	C-30209-2C	REAR BRACKET ASSEMBLY	1	1	1
5	C-23114	AIR SPRING	2	2	2
6	A-30634	LIFT ASSEMBLY BOLT KIT	1	1	1
7	*DWG D-30635	UBL-005 & UBL-005GV LIFT KIT DRAWING	1	1	1
8	*T91001	UBL HARDWARE KIT INFORMATION	1	1	1

\* NOT SHOWN

- NOTES**
- 15" RIDE HEIGHT SHOWN. INSTALLATION IS SAME FOR ALL RIDE HEIGHTS.
  - WEIGHT: 48.48 LB. INCLUDES .11 LB FOR ATTACHMENT WELDS.
  - WELDING PARAMETERS: 28.5 VOLTS, 400 IPM, 275-300 AMPS, 35 CFH GAS FLOW, .045 WIRE. FILL ALL CRATERS AT END OF WELDS.
  - BRAKE CHAMBERS, IF ALREADY MOUNTED, MUST BE REMOVED BEFORE INSTALLING LIFT KIT.
  - IF EXISTING LATERAL BRACING AT FRONT OF FRAME BRACKETS INTERFERES WITH INSTALLATION OF THE LIFT KIT FRONT BRACKETS, BRACING MUST BE MODIFIED OR REMOVED AND RELOCATED. CONTACT HENDRICKSON TRAILER COMMERCIAL VEHICLE SYSTEMS AT 866-RIDEAIR (866-743-3247).
  - THE LIFT BRACKET WELDING SHOWN ON PAGE 1 SHOULD BE PERFORMED WITH THE SUSPENSION INVERTED TO ALLOW THE WELDS TO BE APPLIED IN THE DOWNHAND POSITION. ID TAG TO BE ATTACHED TO OUTBOARD SIDE OF FRONT BRACKET USING DRIVE RIVET.

**LIFT BRACKET INSTALLATION**

**ASSEMBLY PROCEDURE**

\*UBL CANNOT BE INSTALLED WITH SUSPENSION ASSEMBLED TO FRAME BRACKET (UNITIZED), AS EXCESSIVE WELDING HEAT WILL DAMAGE THE PIVOT BUSHING. SUSPENSION MUST BE DISASSEMBLED FROM FRAME BRACKETS BEFORE WELDING.

- 1 PREPARING THE BEAM SURFACE.** REMOVE PAINT FROM UNDERSIDE OF TRAILING ARM BEAM AS INDICATED BY THE SHADED AREA.
- 2 POSITIONING THE LIFT BRACKET.** LOCATE REAR LIFT BRACKET (ITEM 3 - DRIVER'S SIDE (USA), ITEM 4 - CURB SIDE (USA)) TO UNDERSIDE OF BEAM, INSERTING TAB ON FRONT OF BRACKET INTO SLOT ON BEAM. ALIGN FRONT TAB TO FRONT OF SLOT AND ROTATE BRACKET TO ALIGN REAR TAB WITH EDGE OF BEAM PLATE. TACK INTO PLACE.
- 3 WELDING THE LIFT BRACKET.** COMPLETE ATTACHMENT OF LIFT BRACKET BY WELDING THE FRONT AND SIDES OF THE BRACKET TO THE BEAM AS INDICATED IN "STEP 3" ILLUSTRATION. BE CAREFUL NOT TO EXTEND WELD PAST EDGE OF BEAM PLATE. NO WELDING IS REQUIRED ON THE REAR OF THE BRACKET.

SEE PAGE 2 FOR FRONT BRACKET ASSEMBLY INSTRUCTIONS.

**STEP 1**

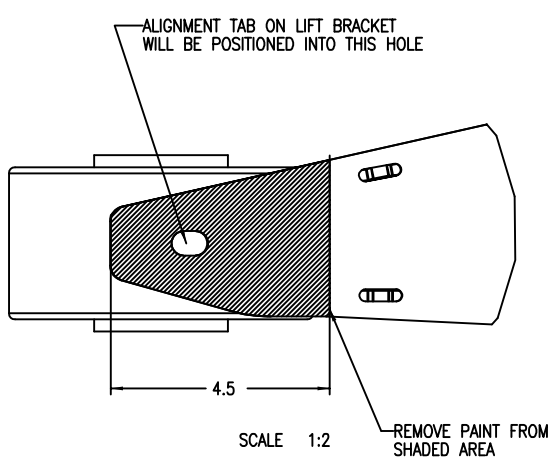

**STEP 2**

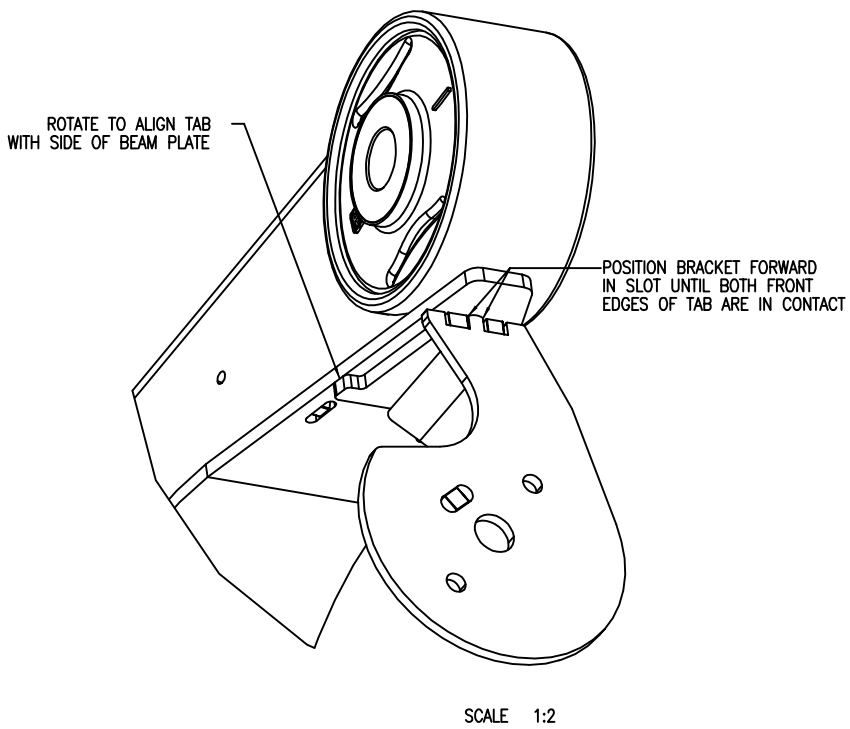

**STEP 3**

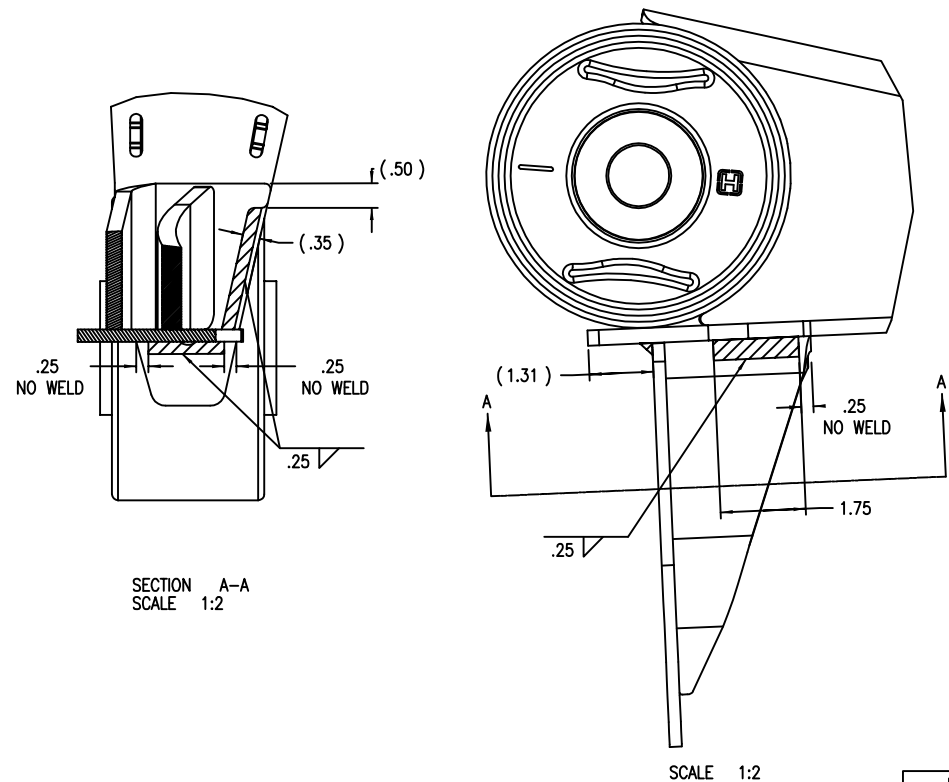

This print remains the property of Hendrickson. All information contained hereon is confidential. It is loaned, subject to return on demand, and on the express condition that it is not to be copied or used directly or indirectly for any purpose other than the purpose for which it has been loaned to you.

**TORQUE SPECIFICATIONS**

DESCRIPTION	SIZE	TORQUE (FT-LB)
AIR SPRING NUT, AIR INLET STUD	3/4-16	45-55
AIR SPRING MOUNTING BOLTS	3/8-16	25-35
SIDE MOUNTING PREVAILING TORQUE NUTS	1/2-13	75-85
FRONT MOUNTING PREVAILING TORQUE NUT	5/8-11	170-210
BRAKE CHAMBER MOUNTING NUTS	5/8-11	100-110

**STEP 4**

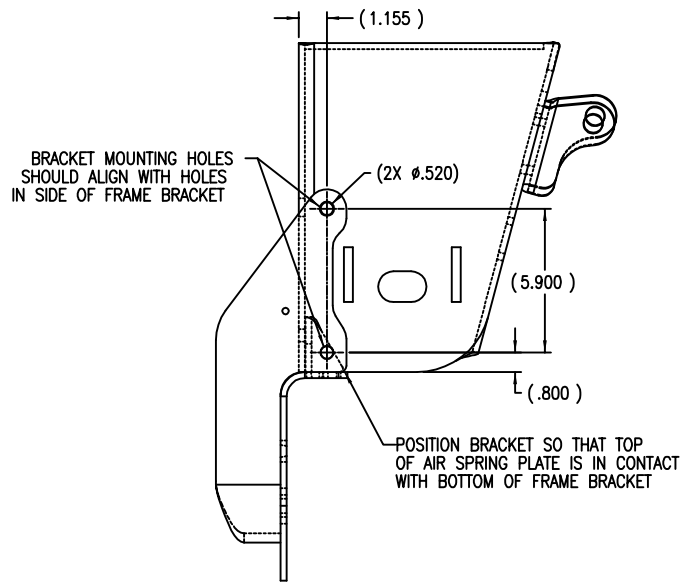

**STEP 5**

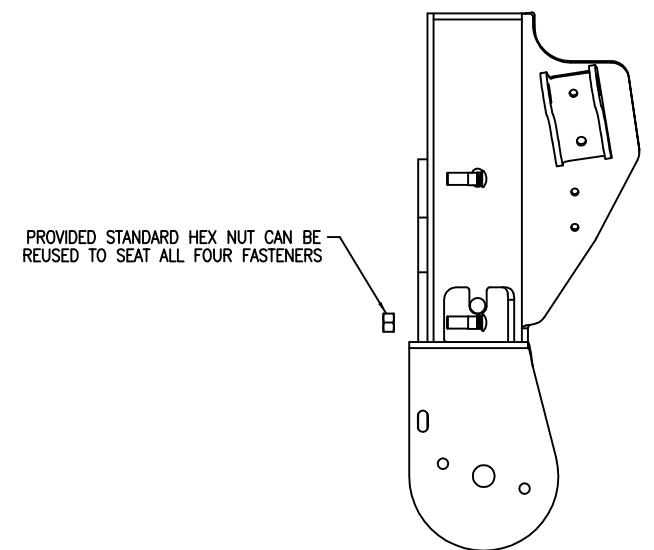

**STEP 6**

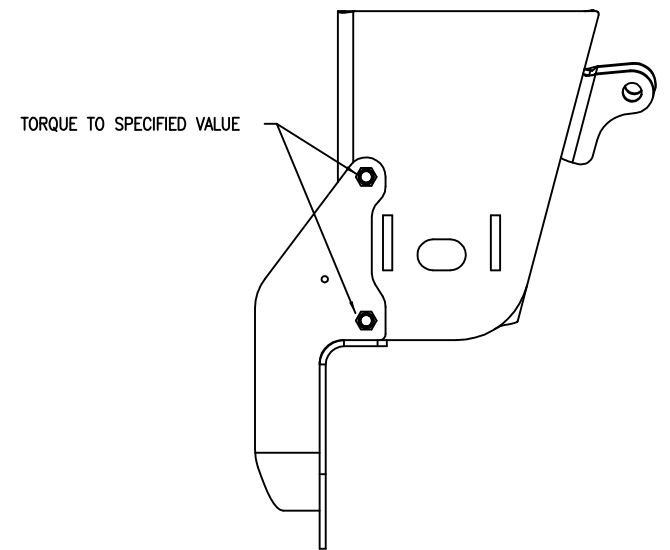

**MODIFICATIONS NECESSARY IF FRAME BRACKETS ARE NOT EQUIPPED WITH MOUNTING HOLES**

1. POSITION FRONT LIFT BRACKET ONTO SUSPENSION FRAME BRACKET.
2. OUTBOARD HOLES: USING TRANSFER PUNCH, CENTER PUNCH TO LOCATE CENTER OF FRONT LIFT BRACKET HOLES ONTO THE OUTBOARD SIDE OF THE SUSPENSION FRAME BRACKET.
3. DRILL PILOT HOLES, SIZE OPTIONAL.
4. DRILL FINISH HOLES USING 33/64" DRILL (.515" DIA.)
5. FRONT HOLE: CHECK TO SEE IF FRONT HOLE IS PRESENT AT CENTER OF FRAME BRACKET, 1.5" FROM BOTTOM, THAT WILL ACCEPT A 5/8" BOLT. IF NOT, CENTER PUNCH AT THIS LOCATION, PILOT DRILL, AND FINISH DRILL USING A 41/64" DRILL (.640" DIA.)
6. FINISH: IF FRAME BRACKETS HAVE BEEN GALVANIZED, SURFACE OF DRILLED HOLES WILL NEED TO BE SUITABLY RECOATED.

**STEP 7**

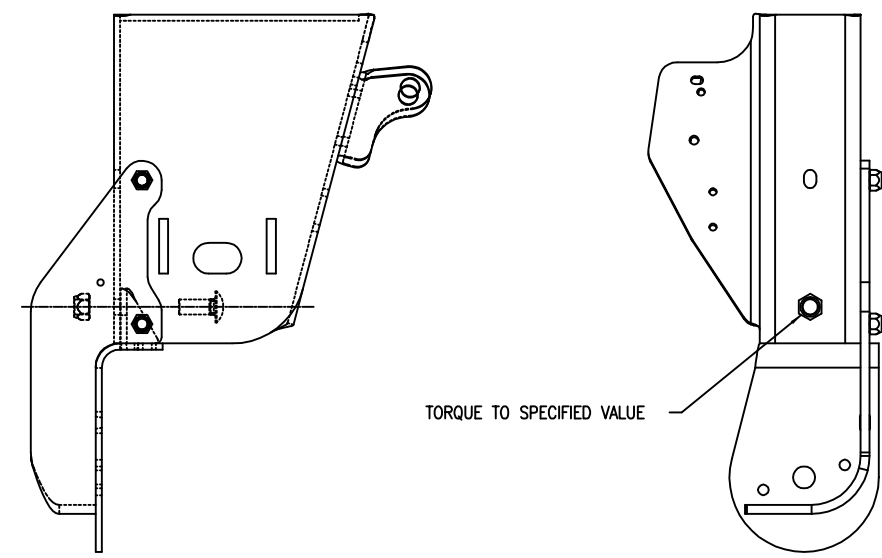

**STEP 8**

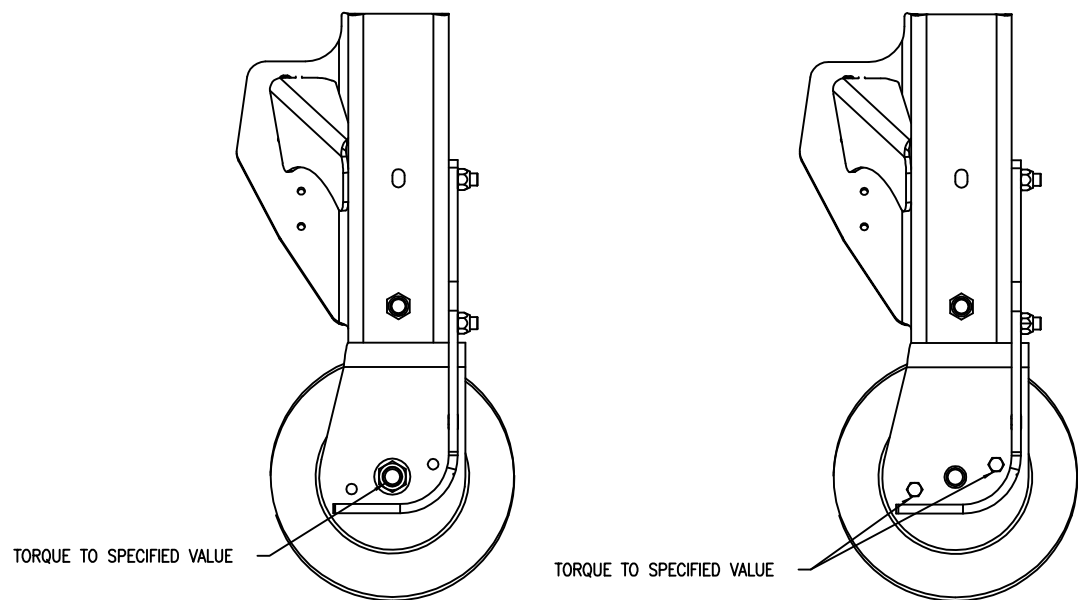

**ALTERNATE INSTALLATION:**  
AIR INLET TOWARD REAR OF SUSPENSION

**ASSEMBLY PROCEDURE**

- \* SUSPENSION MUST REMAIN DISASSEMBLED FROM FRAME BRACKETS FOR FASTENER ACCESSIBILITY DURING FRONT BRACKET INSTALLATION.
  - 4. **FITTING BRACKET INTO PLACE.**  
SLIDE FRONT BRACKET INTO PLACE, MAKING SURE THAT BOTH MOUNTING HOLES IN UBL BRACKET ALIGN WITH HOLES IN FRAME BRACKET. TOP OF AIR SPRING PLATE SHOULD BE IN CONTACT WITH BOTTOM OF FRAME BRACKET.
  - 5. **INSERTING SIDE MOUNTING BOLTS.**  
PUSH RIBBED NECK FASTENERS INTO MOUNTING HOLES FROM INSIDE OF FRAME BRACKET. USE 1/2-13 STANDARD HEX NUT TO FULLY SEAT RIBBED NECK FASTENERS INTO FRAME BRACKET MOUNTING HOLES. (HEX NUT CAN BE REUSED TO SEAT ALL FOUR RIBBED NECK FASTENERS. DO NOT USE PREVAILING TORQUE NUTS TO SEAT RIBBED NECK BOLTS)
  - 6. **TIGHTENING SIDE MOUNTING BOLTS.**  
PLACE 1/2-13 PREVAILING TORQUE NUTS ONTO RIBBED NECK FASTENERS AND TIGHTEN TO VALUE SPECIFIED IN TORQUE SPECIFICATION CHART.
  - 7. **INSTALLING FRONT MOUNTING BOLT.**  
PLACE 5/8-11 X 1.50 CARRIAGE BOLT THROUGH FRONT MOUNTING HOLE WITH THE BOLT HEAD ON THE INSIDE OF THE FRAME BRACKET (NEAREST THE PIVOT BUSHING). HOLD CARRIAGE BOLT IN HOLE AND PLACE 5/8-11 PREVAILING TORQUE NUT ONTO BOLT AND TORQUE TO SPECIFIED VALUE.
  - 8. **AIR SPRING ASSEMBLY.**  
ASSEMBLE THE AIR SPRING WITH THE AIR INLET FACING TO THE FRONT OR REAR, DEPENDING ON AIR LINE ORIENTATION PREFERENCE. TIGHTEN THE 3/4-16 FLANGE NUT AND 3/8-16 X .88 BOLTS TO SPECIFIED TORQUES.
- SEE PAGE 1 FOR REAR LIFT BRACKET ASSEMBLY WELDING INSTRUCTIONS.

This print remains the property of Hendrickson. All information contained hereon is confidential. It is loaned, subject to return on demand, and on the express condition that it is not to be copied or used directly or indirectly for any purpose other than the purpose for which it has been loaned to you.