

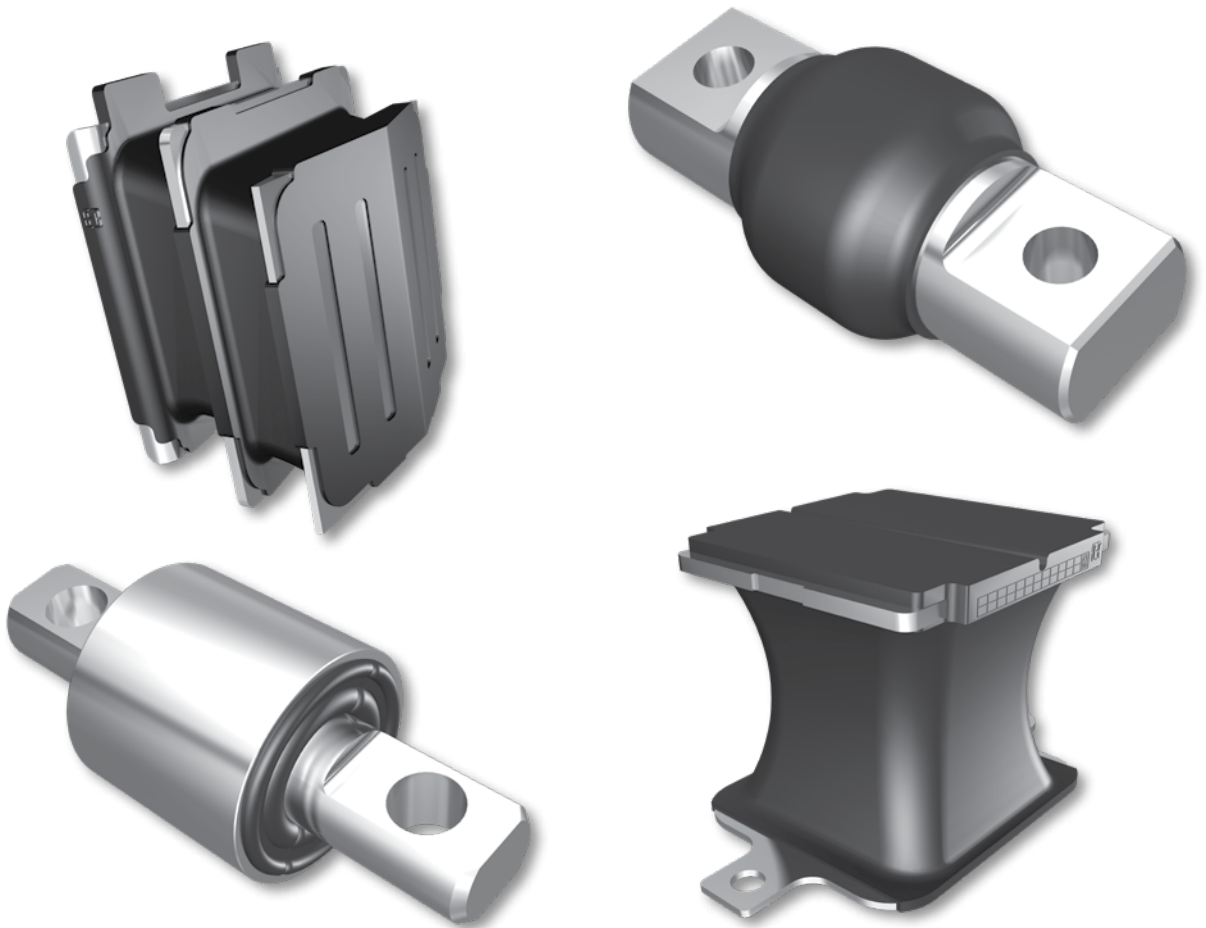

ELASTOMERS

Advanced Rubber Component Technology

- Extended fatigue performance
- Weight efficiency
- Reduced maintenance
- Improved ride quality



Advancing suspension and component technology

Hendrickson leads the advancement of suspension and component technology as a result of more than sixty years of development and over twenty-five years of elastomer manufacturing experience. These accomplishments allow us to fully integrate components, modules and systems that meet commercial vehicle owners demands for durability, weight savings and low life cycle costs.



To learn more about our Elastomers,
call 855.743.3733 or visit
www.hendrickson-intl.com

HENDRICKSON
The World Rides On Us®

Durability Tested to Hendrickson's Rigorous Standards

Component development begins with state-of-the-art engineering software models to identify stress points and simulate suspension performance in various real-world road and load conditions.

Initial designs are built and tested in our advanced research lab, then installed on vehicles for validation in the field.

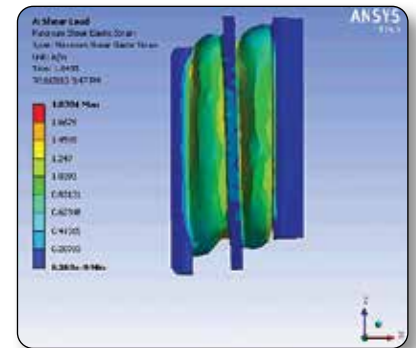
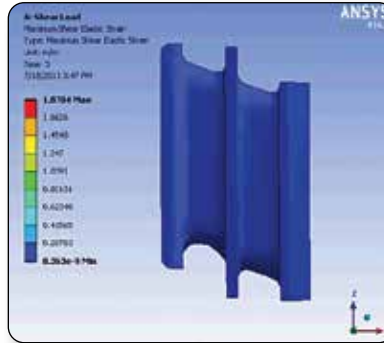

Integrated Component Development Alongside Suspensions and Springs

Our labs feature advanced testing equipment that can test a full range of products to include specific components to full suspension systems.

These simultaneous testing and design capabilities lessen time to market and increase full suspension system quality.



Optimized System Performance and Weight to Meet Application Criteria

All components are designed to strict product requirements, just like our full spring assemblies and suspension systems.

Hendrickson understands the importance of each component design for future evolving application criteria.

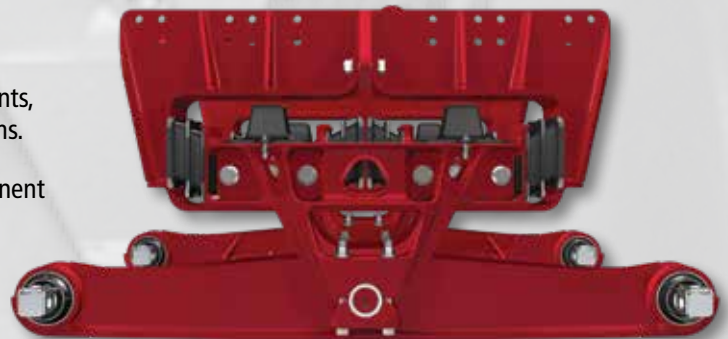

Elastomer Products

Hendrickson's unique elastomer design capabilities result in higher performing, more durable, maintenance-free bushings.

SPRING EYE BUSHINGS

Spring eye bushings are designed as a system providing enhanced spring performance in the areas of roll stability, ride and durability.



Thru Bolt



Split Ring Cartridge



Bar Pin



RUBBER SPRINGS

Our advanced components have re-defined the way rubber spring suspensions perform. The innovative, high-grade rubber designs withstand heavy loads in rugged applications.



Shear Spring (ULTIMAAX®)



Progressive Spring (ULTIMAAX®)



Progressive Spring (ULTIMAAX®)

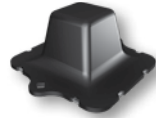

Progressive Spring (ULTIMAAX®)

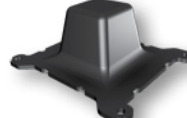

Progressive Spring (HUV®)



Bolster Spring (HAULMAAX®)



Progressive Spring (HAULMAAX®)



Bolster Spring (HAULMAAX®)



Progressive Spring (HAULMAAX®)

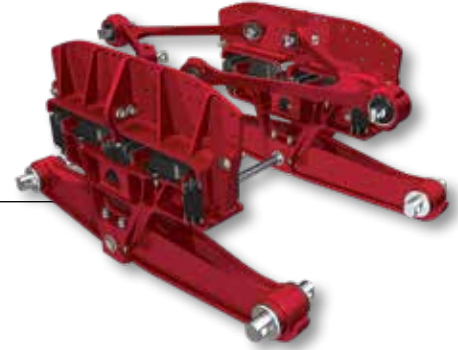

TORQUE ROD BUSHINGS

Unique bonded torque rod bushing designs reduce the friction and heat that often damage ordinary bushings – providing longer life and greater payload. A wide variety of bushing configurations are available to meet various application and attachment needs.



Severe-Duty



Split Ring



Taper Pin



Heavy-Duty



Standard-Duty



BEAM BUSHINGS

Premium rubber beam end bushings provide enhanced flexibility between the beam and the axle to absorb braking and acceleration forces and provide designed articulation / compliance to help ensure high mobility demands. Equalizing beam center bushings are designed for specific types of Hendrickson walking beam suspension capacities and configurations to maximize system performance.



Rate Ring End Bushing



Spherical End Bushing

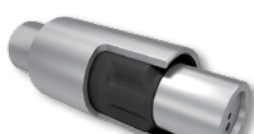







Voided Center Bushing

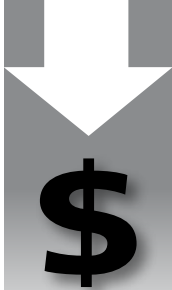

Tri-Functional® III Trailer Bushing

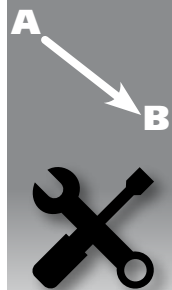

Why Use Rubber in Heavy Truck Suspensions?

						
REDUCE overall suspension weight	LOWER component costs	INCREASE durability	EASE of service and replacement	REDUCE maintenance	PROVIDES isolation and damping	ADD system compliance



Hendrickson Genuine Parts are the same quality components installed in Hendrickson original equipment suspensions — consisting of the same design, construction, performance and durability. There's only one way to maintain and protect your suspension's original performance. Ask for the name that is synonymous with the finest manufactured suspensions in the world.

Actual product performance may vary depending upon vehicle configuration, operation, service and other factors.

All applications must comply with applicable Hendrickson specifications and must be approved by the respective vehicle manufacturer with the vehicle in its original, as-built configuration. Contact Hendrickson for additional details regarding specifications, applications, capacities, and operation, service and maintenance instructions.

Call Hendrickson at **630.910.2800** or **855.RIDERED (743.3733)** for additional information.



TRUCK COMMERCIAL VEHICLE SYSTEMS

800 South Frontage Road
Woodridge, IL 60517-4904 USA
855.RIDERED (743.3733)
630.910.2800 • Fax 630.910.2899

www.hendrickson-intl.com

45745-442 Rev B 05-20

© 2016 - 2020 Hendrickson USA, L.L.C. All Rights Reserved. All trademarks shown are owned by Hendrickson USA, L.L.C., or one of its affiliates, in one or more countries. Information contained in this literature was accurate at the time of publication. Product changes may have been made after the copyright date that are not reflected.

Printed in United States of America