

# **TOUGHLIFT® FRT**

18,000 Pound Lifiable Tag Axle

- High ground clearance
- Outside frame mounting convenience
- Unique single central lift bag design

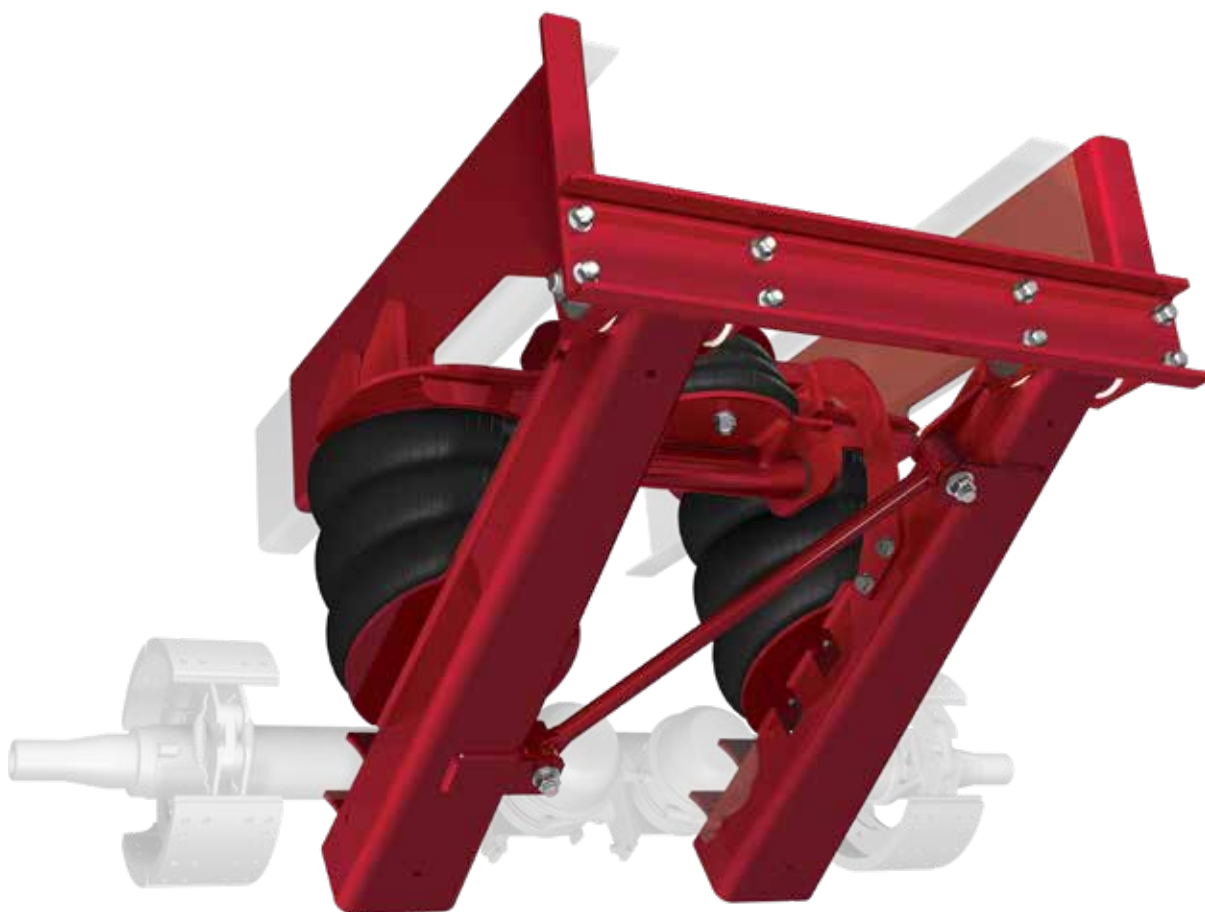

To learn more about TOUGHLIFT FRT,  
call 800.660.2829 or visit  
[www.hendrickson-intl.com](http://www.hendrickson-intl.com)

 **HENDRICKSON**  
*The World Rides On Us®*

# TOUGHLIFT® FRT — 18,

Hendrickson's TOUGHLIFT® FRT is engineered for tag applications that require high-ground clearance and high-load capacity. Ease of installation is the heart of the design for the 18,000 pound capacity axle; just slip the suspension over the rails, secure and align. Custom side rail drilling patterns available upon request to further aid installation.

The FRT18 is set apart from other Hendrickson lift axles by a single central lift bag that has a pivoting base in order to maintain optimum air spring operation. Designed specifically for the boom and crane industry for block or drywall chassis vehicle applications.



— Axle placement at rear of suspension beams to maximize lift and travel

# 000 Pound Liftable Tag Axle

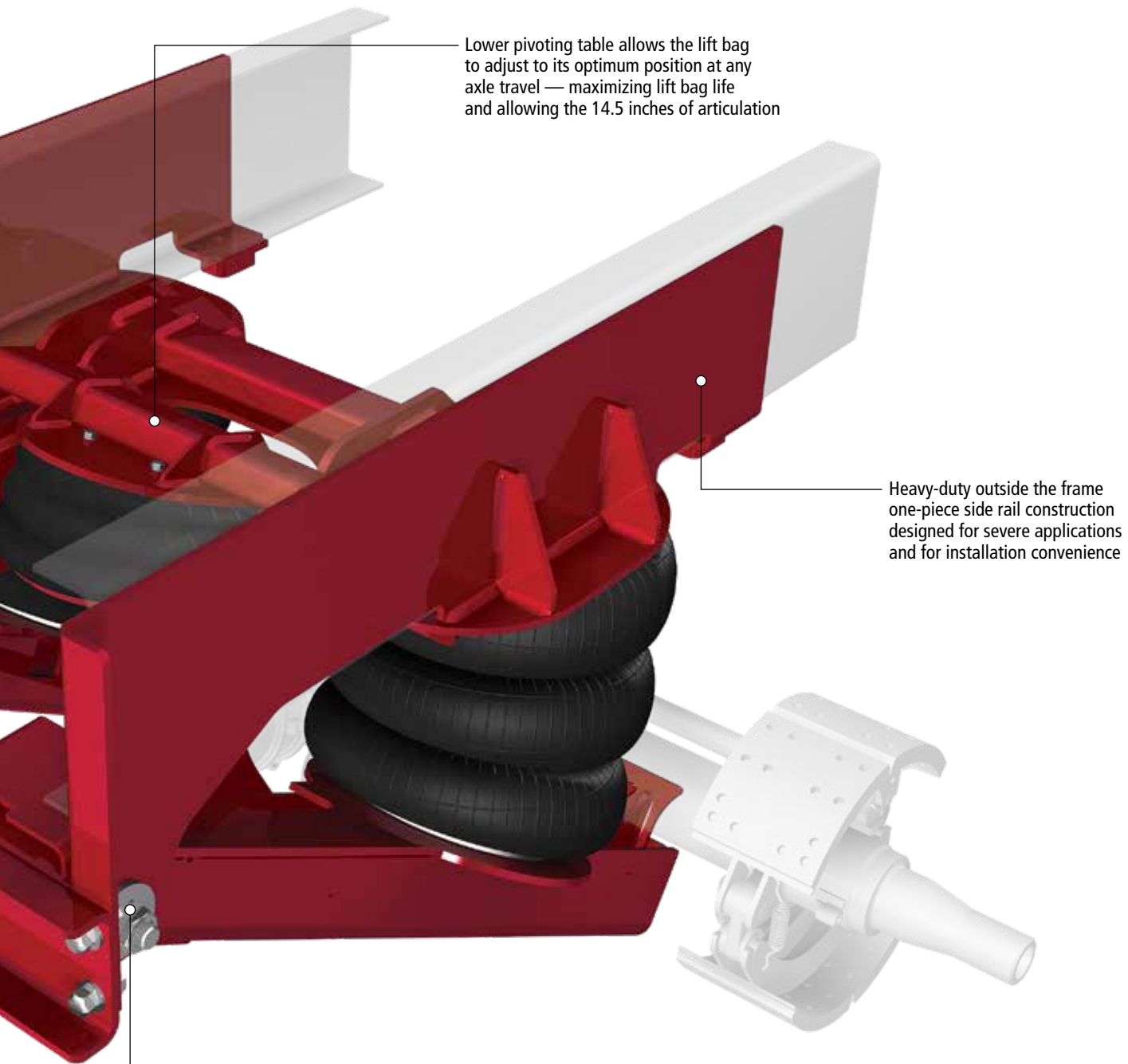

Lower pivoting table allows the lift bag to adjust to its optimum position at any axle travel — maximizing lift bag life and allowing the 14.5 inches of articulation

Heavy-duty outside the frame one-piece side rail construction designed for severe applications and for installation convenience

Adjustable collar pivot connection for setting alignment

## FRT 18K Specifications

Capacity:	Up to 18,000 pounds
Weight:	1,350 pounds
Travel:	14.5 inches
Lift:	10.5 inches
Packaging Space:	43.1 inches

# TOUGHLIFT® FRT Features and Benefits

## High pivot point

Allows for significant ground clearance range and axle travel.

## Transverse torque rod

Locks in lateral stiffness for extreme turning applications and better maneuverability.

## Lift spring optimum performance feature

Specially designed lifting mechanism to allow for outside frame mounting ease and service.

## Value-Added Options

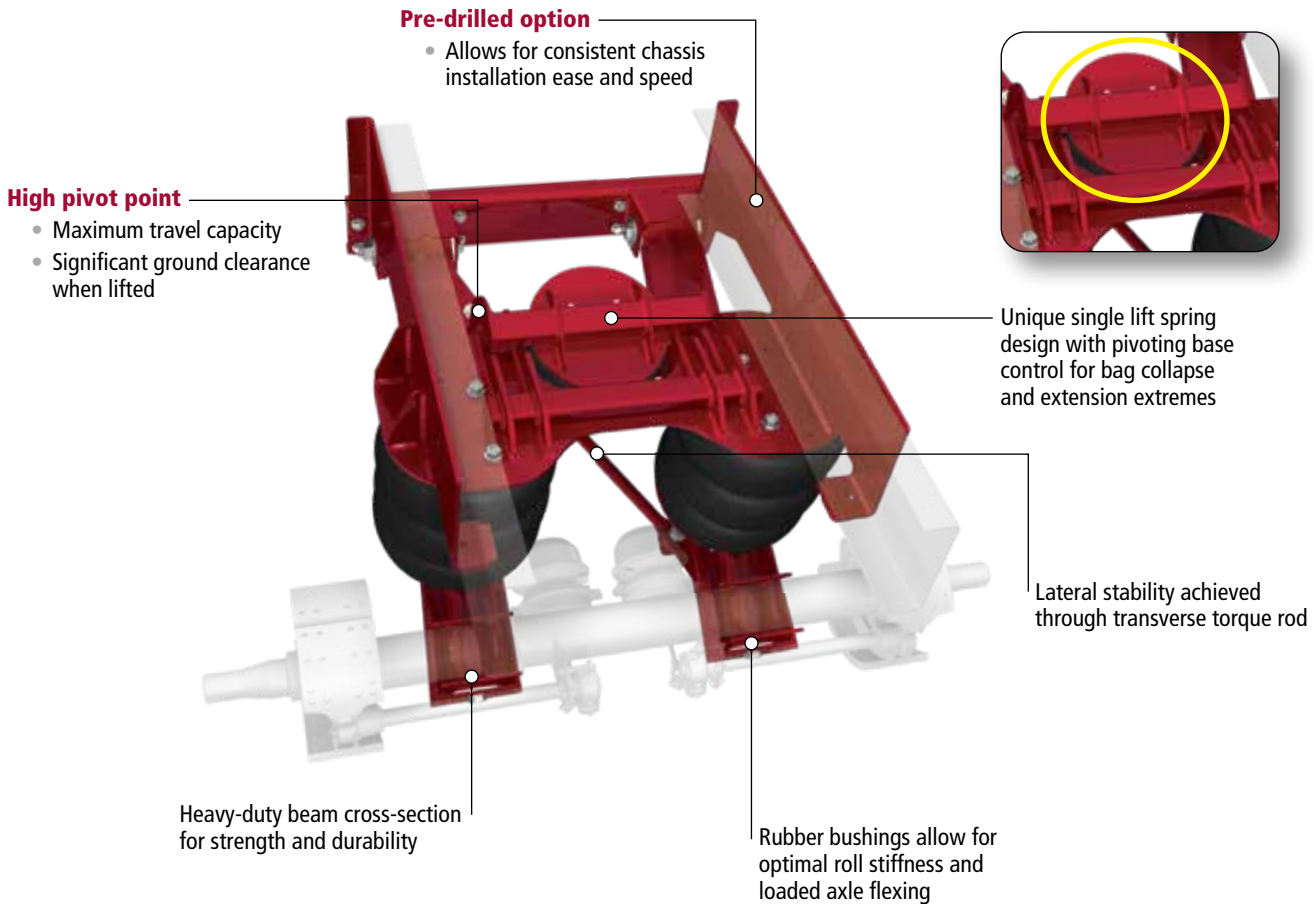

## Wheels

Typically supplied for use with  
12.25 × 7.5 brakes for 17.5 tires

*Actual product performance may vary depending upon vehicle configuration, operation, service and other factors.  
All applications must comply with applicable Hendrickson specifications and must be approved by the respective vehicle manufacturer with the vehicle in its original, as-built configuration.  
Contact Hendrickson for additional details regarding specifications, applications, capacities, and operation, service and maintenance instructions.*

Call Hendrickson at **800.660.2829** or **800.668.5360** in Canada for additional information.



**SPECIALTY PRODUCTS -  
AUXILIARY AXLE SYSTEMS**  
277 North High Street  
Hebron, OH 43025 USA  
800.660.2829  
740.929.5600 • Fax 740.929.5601

**Hendrickson Canada**  
250 Chrysler Drive, Unit #3  
Brampton, ON Canada L6S 6B6  
800.668.5360  
905.789.1030 • Fax 905.789.1033

[www.hendrickson-intl.com](http://www.hendrickson-intl.com)

H804 06-20

© 2016 - 2020 Hendrickson USA, L.L.C. All Rights Reserved. All trademarks shown are owned by Hendrickson USA, L.L.C., or one of its affiliates, in one or more countries.  
Information contained in this literature was accurate at the time of publication. Product changes may have been made after the copyright date that are not reflected.

Printed in United States of America