

- Proven Performance
- Proven Durability
- Reduced Maintenance
- Available with TIREMAAX®

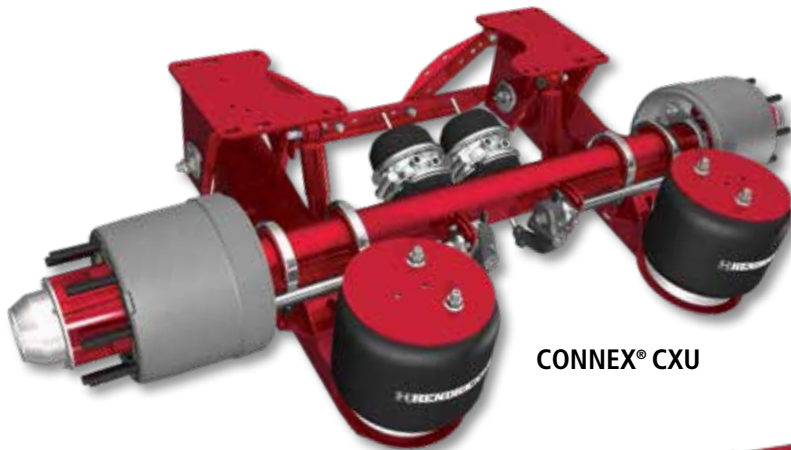

CONNEX® CXU



CONNEX® CXY

Proven Performance

CONNEX® trailer air suspension delivers a complete system that offers maximized operating efficiency and legendary durability. The patented[▲] TRI-FUNCTIONAL® Bushing in unison with a rigid beam and solid axle connection provides the ideal combination of ride softness and roll stability. CONNEX is ideal for application where INTRAAX® options are not available

Proven Durability

Thoroughly tested in Hendrickson's world-class research and development test lab as well as various road and durability track testing, the CONNEX trailer air suspension stands up to rigorous demands in the field. CONNEX is an excellent example of Hendrickson's commitment to setting high quality and durable standards for their products.

Reduced Maintenance

CONNEX trailer air suspension uses a rigid trailing arm and solid axle connection to reduce the number of moving parts, bushings and fasteners to help minimize maintenance requirements. This provides superior stability while eliminating torque rods, stabilizer bars and re-torquing requirements. CONNEX uses low spring rates for exceptional ride quality and large bore shocks for longer life.

[▲]This product is covered by at least one or more U.S. and/or foreign patents and/or pending U.S. and/or foreign patent applications. See Hendrickson for details.



To learn more about CONNEX,
call 866.743.3247 or visit
www.hendrickson-intl.com

CONNEX[®] Features and Benefits

TRI-FUNCTIONAL[®] Bushings

- Controls vertical, horizontal and roll forces of trailer
- Optimizes ride stiffness, control and stability

Frame Bracket Compatibility

- INTRAAX[®] -like installation
- Versatile bolt pattern for more flexible mounting options

Hendrickson Integrated Brakes

- Simplify brake installation and service while optimizing weight

QUIK-ALIGN[®] Pivot Connection

- Fast and easy axle alignment
- Requires no welding or special tools

RTR[®] READY-TO-ROLL[®] Wheel-End Package

- HXL5[®] and HXL3[®] wheel-end package standard
- Hubcap to hubcap coverage from Hendrickson

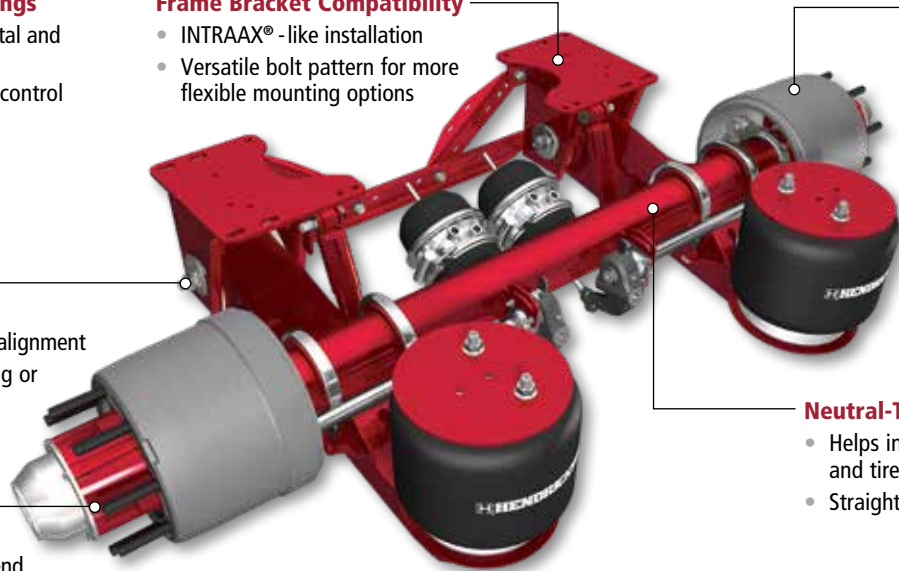

Neutral-Toe Axle

- Helps increase fuel economy and tire life
- Straight tracking

Specifications

SUSPENSION	MAXIMUM CAPACITY (lbs.)	AXLE RATING ¹ (lbs.)	AXLE DIAMETER (Inches)	RIDE HEIGHTS (Inches)	BASE MODEL WEIGHT (lbs.)
CXU 23K	23,000	23,000	5	5.5, 6.5, 7.5, 9.0	965 ²
CXU 25K	25,000	25,000	5	5.5, 6.5, 7.5, 9.0	980 ²
CXY 23K	23,000	23,000	5	6.5, 7.5, 9.0	1039 ³
CXY 25K	25,000	25,000	5	6.5, 7.5, 9.0	1054 ³

1. Axle structure rating only. Brakes rated separately.

2. Based on 6.5" ride height, wingless, weld-on frame brackets model with 77.5" axle track, 12.25" x 7.50" brake package and fully dressed HXL5[®] wheel-end package with drums, slacks and chambers.

3. Based on 6.5" ride height, model with 77.5" axle track, 12.25" x 7.50" brake package and fully dressed HXL5 wheel-end package with drums, slacks and chambers.

• TIREMAAX[®] tire inflation system options

- TIREMAAX PRO provides constant pressure with active inflation, relieving and equalizing
- TIREMAAX CP offers a straightforward solution for keeping tires inflated

• Suspension Mounting Type

- Weld-on or bolt-on available
- Y-Beam Suspension type

See RTR READY-TO-ROLL Flyer - Literature No. L1200

See TIREMAAX Flyer - Literature No. L1017

• 12.25" x 7.50" (20K) drum brakes

- Type 30 and 30 / 30 chambers available
- 16.50" x 7.00" and 16.5" x 8.625" (20K, 23K and 26K). Drum brake sizes also available.
- 5.5" or 6" slack

• Axle track widths

- 71.5" or 77.5" only

• Spindle options

- HP or HN

5-Year Axle-to-Beam Connection Warranty*

*Contact your local Hendrickson representative or refer to L583 Comprehensive Warranty Statement for complete warranty terms, conditions and limitations.

Actual product performance may vary depending upon vehicle configuration, operation, service and other factors.

All applications must comply with applicable Hendrickson specifications and must be approved by the respective vehicle manufacturer with the vehicle in its original, as-built configuration.

Contact Hendrickson for additional details regarding specifications, applications, capacities, and operation, service and maintenance instructions.

Call Hendrickson at 330.489.0045 or 866.RIDEAIR (743.3247) for additional information.



www.hendrickson-intl.com

TRAILER COMMERCIAL VEHICLE SYSTEMS

2070 Industrial Place SE
Canton, OH 44707-2641 USA
866.RIDEAIR (743.3247)
330.489.0045 • Fax 800.696.4416

Hendrickson Canada

250 Chrysler Drive, Unit #3
Brampton, ON Canada L6S 6B6
800.668.5360
905.789.1030 • Fax 905.789.1033

Hendrickson Mexicana

Circuito El Marqués Sur #29
Parque Industrial El Marqués
Pob. El Colorado, Municipio El Marqués,
Querétaro, México C.P. 76246
+52 (442) 296.3600 • Fax +52 (442) 296.3601