

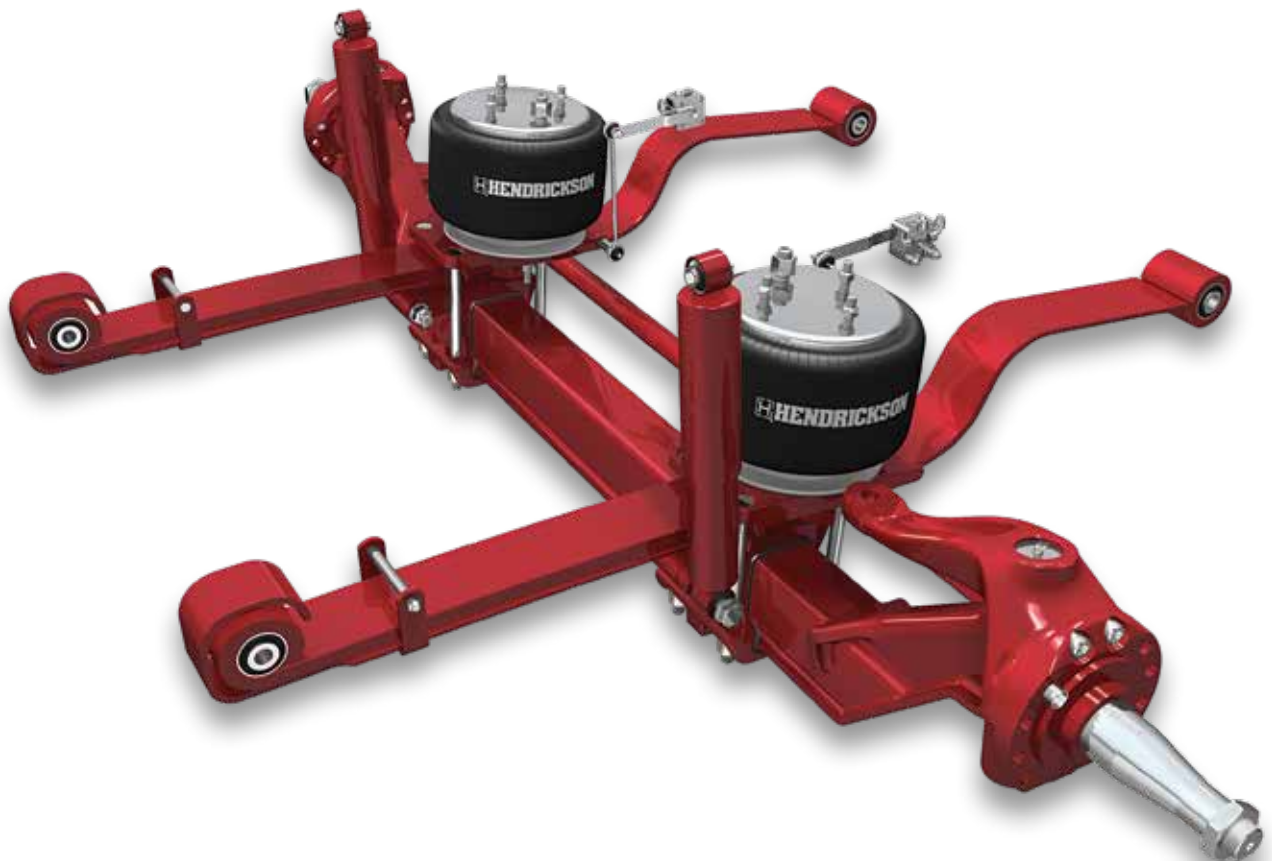

AIRTEK® delivers driver and passenger comfort, outstanding stability on IC Bus® RE Series



An IC Bus RE Series bus equipped with Hendrickson's AIRTEK® integrated front air suspension and STEERTEK™ axle combines simple, functional design and advanced technology for superior ride, stability and handling. The same smooth, comfortable ride that cradles passengers and drivers reduces vibration-induced wear-and-tear on the bus itself to help extend overall vehicle and component durability. Capacities of 12,000 and 14,000 pounds are now available.



To learn more about AIRTEK,
call 855.743.3733 or visit
www.hendrickson-intl.com

H HENDRICKSON
The World Rides On Us®

AIRTEK® Features and Benefits

Improved Ride and Comfort

- Leaf spring assembly forms torsion system with the axle to increase roll stability
- Dual height control valves react quickly to maintain proper ride height for shifting or unequal loads

Driver and Passenger Comfort

- High-volume air springs support approximately half of the vertical load while offering a softer, more comfortable ride

Warranty

- AIRTEK® for IC Bus® utilizes the STEERTEK™ axle, which comes with a 10-year, 1 million mile limited warranty*

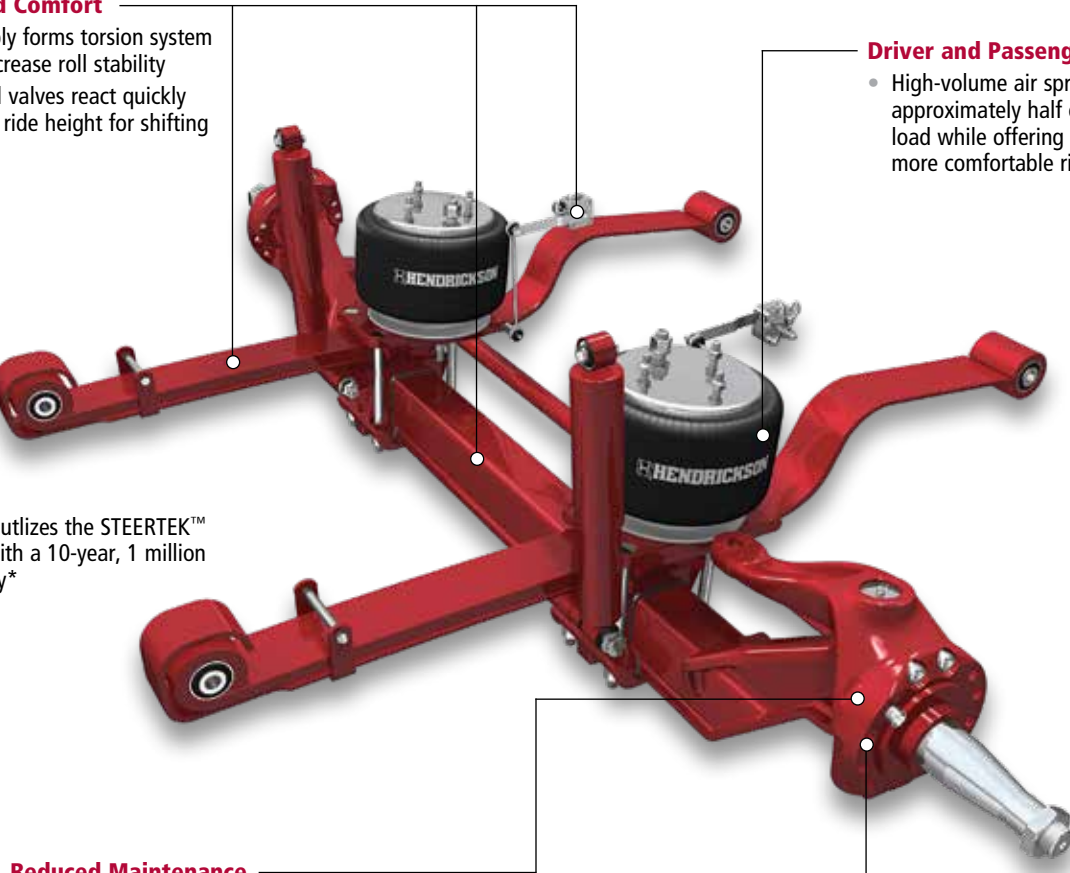

Reduced Maintenance

- Durable rubber front and rear bushings require no lubrication
- Unique two-piece knuckle design eliminates the need to remove the kingpin to service the knuckle

Up to 50 Degrees of Wheel Cut

- Superior maneuverability in tight spaces, such as parking lots and city streets



Two-piece knuckle design

CAPACITY	SUSPENSION	DATA CODE
12,000 lbs.	AIRTEK®	03AZE
14,000 lbs.	AIRTEK	03AZH

*10-year, 1 million mile limited warranty covers certain structural components only. Warranty coverage applies to the axle beam, steering arm, knuckle assembly and kingpin when used in applications approved by Hendrickson and within the proper guidelines of the product. Warranty does not cover components experiencing normal wear. Contact Hendrickson for full warranty details and limitations.

Actual product performance may vary depending upon vehicle configuration, operation, service and other factors.

All applications must comply with applicable Hendrickson specifications and must be approved by the respective vehicle manufacturer with the vehicle in its original, as-built configuration. Contact Hendrickson for additional details regarding specifications, applications, capacities, and operation, service and maintenance instructions.

Call Hendrickson at **630.910.2800** or **855.RIDERED (743.3733)** for additional information.



www.hendrickson-intl.com

TRUCK COMMERCIAL VEHICLE SYSTEMS

800 South Frontage Road
Woodridge, IL 60517-4904 USA
855.RIDERED (743.3733)
630.910.2800 • Fax 630.910.2899



www.icbus.com

45745-517 03-20

© 2020 Hendrickson USA, L.L.C. All Rights Reserved. All trademarks shown are owned by Hendrickson USA, L.L.C., or one of its affiliates, in one or more countries, except for IC Bus and the IC Bus logo, which are owned by IC Bus, L.L.C. Information contained in this literature was accurate at the time of publication. Product changes may have been made after the copyright date that are not reflected.

Printed in United States of America