

# TECHNICAL BULLETIN

## HAULMAAX® 460

**SUBJECT:** Bolster Spring Assembly  
with Tie-bar

**LIT NO:** SEU-0225

**DATE:** June 2006

**REVISION:** A

### IMPORTANT NOTICE

The unique spring system in HAULMAAX® adjusts to the load, delivering the preferred combination of empty ride and loaded stability for vocational applications. Further, this innovative suspension significantly reduces wheel hop by eliminating the fixed pivot point found in the center bushings of other walking beam suspensions.

Effective in June of 2006, a new enhanced bolster spring package will be phased into production for the HAULMAAX 460 suspension system. The new design features a tie-bar, which connects the bolster springs using a bolt, spacer, and nut. This newly enhanced bolster spring package is intended for all HAULMAAX 460 applications. The bolster spring design for the HAULMAAX 400 system will remain the same, although a new tie-bar bolster spring kit, in addition to the current bolster spring kit, will be available in the aftermarket for HAULMAAX 400 component replacement.

### THE NEW DESIGN

- Provides greater bolster rigidity with the use of a tie-bar for severe service applications
- Helps maintain suspension performance even in the event of any axle misalignment
- Remains consistent with the ride quality and stability of the original design

For production parts, Hendrickson will pre-assemble the tie-bar connection and include the feature with the HAULMAAX beam and saddle assembly. Therefore, no changes to the OEM installation procedures are necessary. There is a weight increase of two pounds per beam and saddle assembly due to the new enhancement.

**Figure 1** HAULMAAX 460  
Prior Production Bolster Spring Assembly



**Figure 2** HAULMAAX 460  
New Production Bolster Spring Assembly with Tie-bar

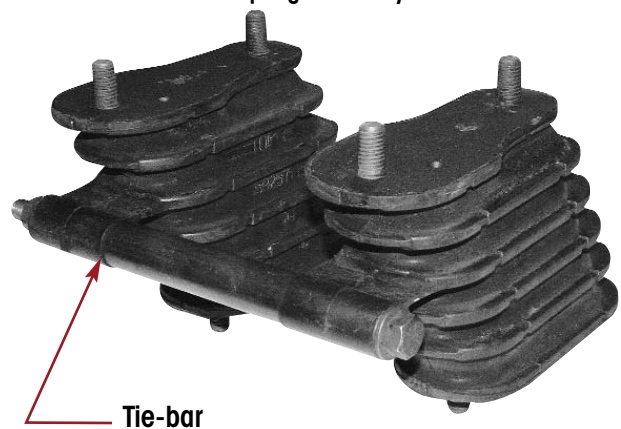

## AFTERMARKET

Currently for service in the aftermarket, the HAULMAAX bolster springs are sold in pairs; this process will remain the same for the new tie-bar bolster springs.

### HAULMAAX 460

Effective June 2006, Hendrickson will only offer the new tie-bar bolster spring – **Kit No. 64179-037** for HAULMAAX 460 suspension service purposes. Installation of the tie-bar bolster spring is similar to existing bolster springs, with the addition of the tie-bar spacer, bolt, and locknut.

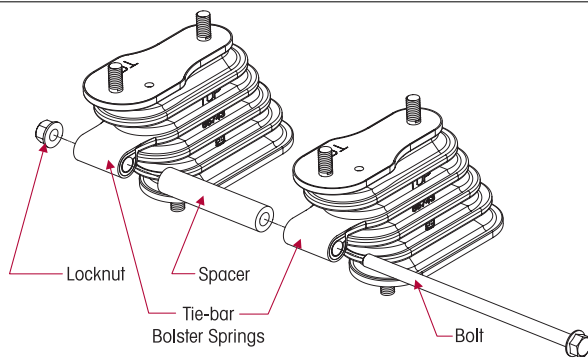

#### BOLSTER SPRING WITH TIE-BAR KIT NO. 64179-037

PART NO.	DESCRIPTION	QTY.
65743-000	HAULMAAX Tie-bar Bolster Springs	2
65742-000	Bolster Spring Spacer	1
60818-003	½"-13 UNC 10" Flange Bolt	1
60819-000	½"-13 UNC Flange Nut	9

### HAULMAAX 400

All HAULMAAX 400 suspensions can continue to be serviced using the existing bolster springs – **Kit No. 64179-002** or, if desired, can be replaced with the tie-bar bolster spring **Kit No. 64179-037**. Contact Hendrickson Tech Services with any questions regarding the use of either bolster spring kit in your particular application.

#### BOLSTER SPRING KIT NO. 64179-002

PART NO.	DESCRIPTION	QTY.
59257-000	HAULMAAX Bolster Springs	2
60819-000	½"-13 UNC Flange Nut	8

Remember, there's only one way to ensure the suspension's original performance: *Ask for Hendrickson Genuine Parts by name.* Contact Hendrickson Tech Services (630.910.2800 or email [techservices@hendrickson-intl.com](mailto:techservices@hendrickson-intl.com)) for any questions regarding this publication. For technical information, please visit [www.hendrickson-intl.com/literature.asp](http://www.hendrickson-intl.com/literature.asp).

[www.hendrickson-intl.com](http://www.hendrickson-intl.com)



Truck Suspension Systems  
800 South Frontage Road  
Woodridge, IL 60517-4904 USA

630.910.2800  
Fax 630.910.2899