

HHK™ **SERIES**

HK190T / HK230 SPECIFICATIONS

LIT NO: L490

DATE: June 2007

REVISION: B

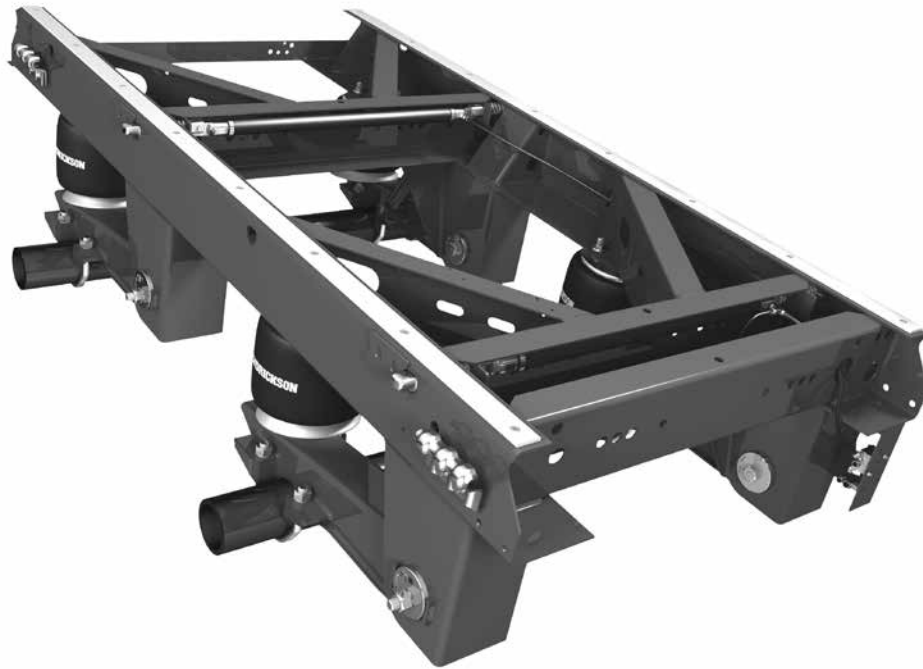

TABLE OF CONTENTS

APPLICATIONS	2
SPECIFICATIONS	2
Slider / Suspension	2
OPTIONS	3
Ride Heights.....	3
Air Tank Brackets	3
Air Tank Mounting Hardware Kits.....	3
Manual Stop Bar.....	3
SURELOK®	3
Stinger.....	3
Mud Flap Mounting Angle	3



APPLICATIONS		
	HK190T	HK230
CAPACITY:	40,000 lbs. (18 000 kg)	46,000 lbs. (20 700 kg)
TRAILER TYPES:	UNITED STATES AND CANADA Van Reefer	MEXICO, CENTRAL AND SOUTH AMERICA None
*AXLE DATA:	5-inch diameter round	
AXLE ARRANGEMENT:	49-inch maximum tandem spacing	
PIN-PULL MECHANISM:	Fully pneumatic QUIK-DRAW®	
FRAME TYPES:	Steel only; 96-inch or 102-inch wide trailers	

*Hendrickson recommends 0.625" nominal wall thickness.

SPECIFICATIONS

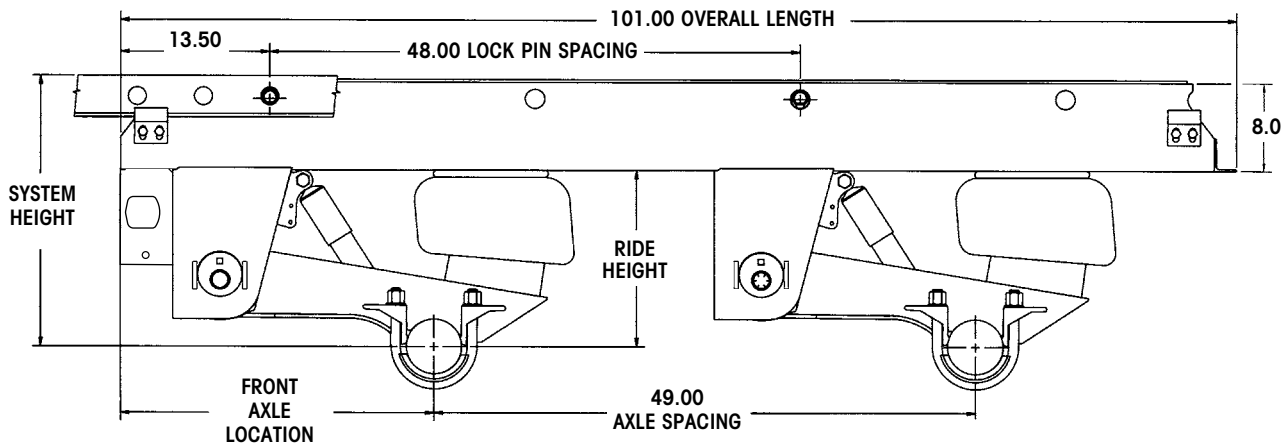

SLIDER / SUSPENSION						
RIDE HEIGHT (inches)	SYSTEM HEIGHT (inches)	FRONT AXLE LOCATION (inches)	JOUNCE (inches)	REBOUND (inches)	WEIGHT (48-inch Wide Box)	
					HK190T	HK230
16	24.5	28.4	3.0	3.0	1011 lbs	1008 lbs
17	25.5	28.7	3.1	3.0	1021 lbs	1028 lbs
18	26.5	28.4	3.1	3.1	1027 lbs	1034 lbs
19	27.5	28.0	3.1	3.1	1032 lbs	1039 lbs

NOTE: Weight includes all slider and tandem suspension components and QUIK-DRAW pin-pull mechanism. Axle and body rail weights are not included. Add 9 pounds for spacer plates. Deduct 12 pounds for a 42-inch wide box.

**OPTIONS****RIDE HEIGHTS**

16-inch to 19-inch.

AIR TANK BRACKETS

Weldable bracket accommodates 27½-inch to 32-inch long air tanks. Two brackets are required per air tank.

AIR TANK MOUNTING HARDWARE KITS

Available for 42-inch and 48-inch boxes.

MANUAL STOP BAR

Efficiently assists the driver in slider box repositioning.

SURELOK®

Dock height lock that maintains trailer at deck height while minimizing trailer walk during loading and unloading.

STINGER

Bolt-on bracket available in 32- or 36-inch length; mounts on either road or curbside of suspension.

MUD FLAP MOUNTING ANGLE

Bolt-on bracket, attaches to rear cross member.

*Actual product performance may vary depending upon vehicle configuration, operation, service and other factors.
All applications must comply with applicable Hendrickson specifications and must be approved by the respective vehicle manufacturer with the vehicle in its original, as-built configuration.
Contact Hendrickson for additional details regarding specifications, applications, capacities, and operation, service and maintenance instructions.*

Call Hendrickson at 330.489.0045 or 866.RIDEAIR (743.3247) for additional information.



www.hendrickson-intl.com

TRAILER COMMERCIAL VEHICLE SYSTEMS

2070 Industrial Place SE
Canton, OH 44707-2641 USA
866.RIDEAIR (743.3247)
330.489.0045 • Fax 800.696.4416

Hendrickson Canada

250 Chrysler Drive, Unit #3
Brampton, ON Canada L6S 6B6
800.668.5360
905.789.1030 • Fax 905.789.1033

Hendrickson Mexicana

Circuito El Marqués Sur #29
Parque Industrial El Marqués
Pob. El Colorado, Municipio El Marqués,
Querétaro, México C.P. 76246
+52 (442) 296.3600 • Fax +52 (442) 296.3601

L490 Rev B 06-07

© 1996 - 2020 Hendrickson USA, L.L.C. All Rights Reserved. All trademarks shown are owned by Hendrickson USA, L.L.C., or one of its affiliates, in one or more countries.
Information contained in this literature was accurate at the time of publication. Product changes may have been made after the copyright date that are not reflected.

Printed in United States of America