

TECHNICAL PROCEDURE

ULTRAA-K™ SLIDER SUSPENSION

SUBJECT: Pivoting Mud Flap Kit
Installation Procedures

LIT NO: T91004
DATE: April 2015

REVISION A

INTRODUCTION

This procedure includes illustrated steps for installing Hendrickson's pivoting mud flap kit (roadside & curbside bracket assemblies) to the rear end of an ULTRAA-K™ slider suspension. The illustrated steps shown are for the roadside rear. All steps are to be mirrored and repeated for the curbside rear bracket. Review the entire procedure before you begin.

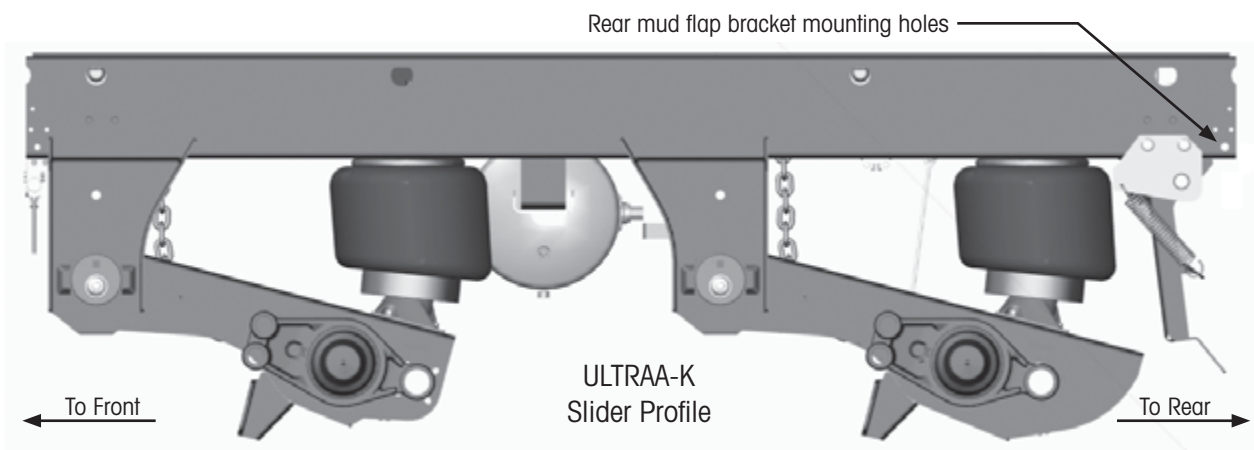

NOTE: Installation is best performed without mud flaps attached to mud flap angle.

BRACKET INSTALLATION

Step 1: Slide bracket over rail in orientation shown. Use radii of rail to aid in positioning.

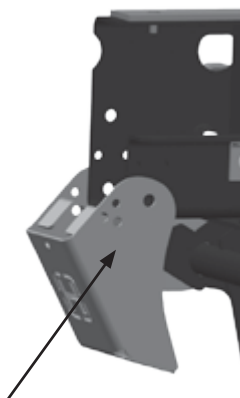

Step 2: Insert clevis pin as shown, with hole for cotter pin **INBOARD**.

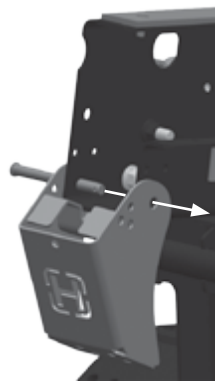

Step 3: Place washer over clevis pin.

Step 4: Insert Bow-Tie Locking Cotter pin.

NOTE: Be sure to place cotter pin inboard as shown.

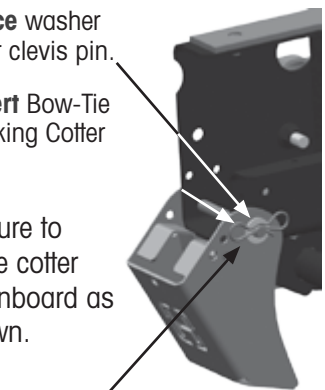

Properly installed bow-tie cotter pin



EYE-BOLT INSTALLATION

Step 1: Locate SURELOK® gusset.

Step 2: Use hole to insert eye bolt as seen below...

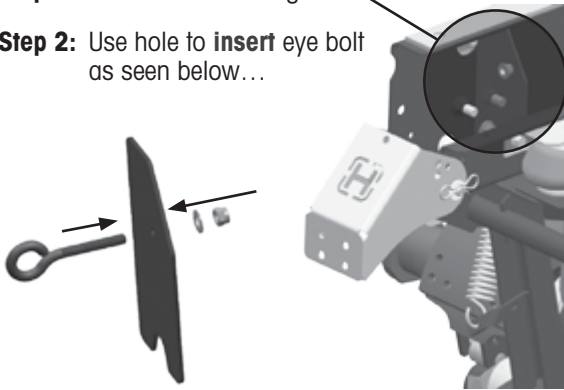

Step 3: Install washer and nut just to point of showing threads.

Step 4: Hook non-extended spring into eye-bolt.

Step 5: Loop spring hook through top hole of bracket.

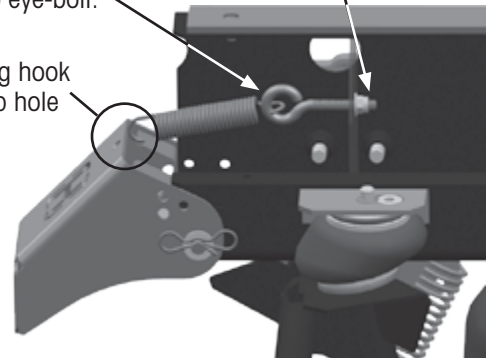

Step 6: While holding eye bolt to prevent rotation, **thread** the prevailing torque nut all the way down until it bottoms out at the end of the threads.

NOTICE: Damage may occur to spring if eyebolt is allowed to rotate.

IMPORTANT: This must be done to properly tension spring.

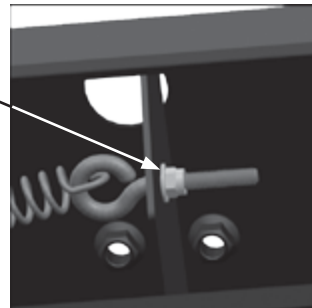

NOTE: The installed bracket should be seen, as shown below.

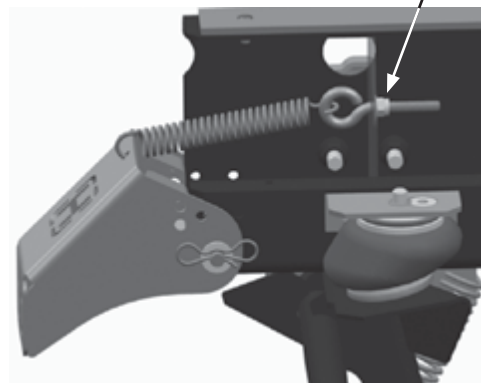



PIVOTING MUD FLAP KIT INSTALLATION PROCEDURES

MUD FLAP ANGLE INSTALLATION

Step 1: Orient mud flap angle to bracket as shown.

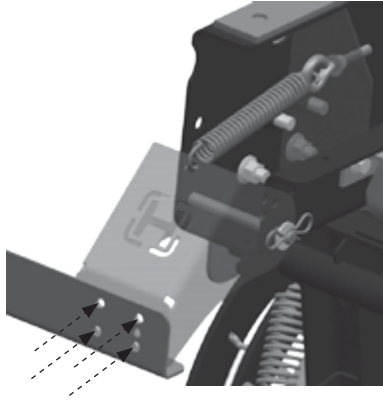

Step 2: Fasten mud flap angle to bracket using 4 of the 3/8" nuts and bolts provided.

NOTE: Fasteners may be installed in either direction as shown below.

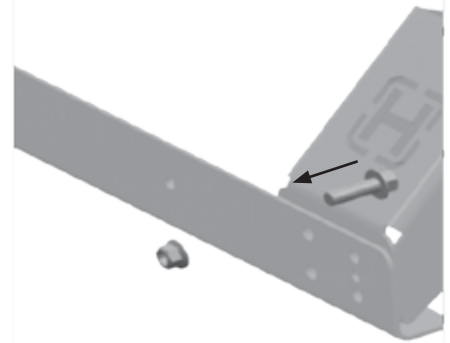
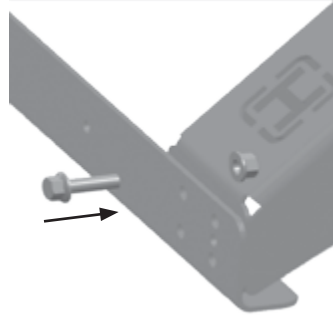

IMPORTANT: Ensure mud flap angle is parallel to ground when installing.

Step 3: While holding mud flap angle parallel to ground, **tighten** and torque bolts to 30 ft. lbs.

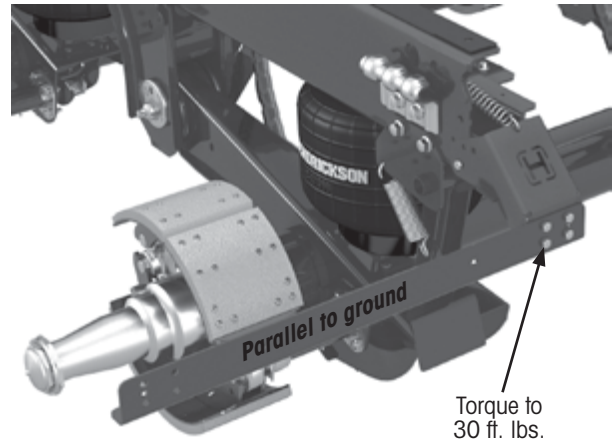

MUD FLAP BRACKET INSTALLATION COMPLETE FOR ROADSIDE

The assembled pivoting mud flap assembly can be seen below (roadside shown)...

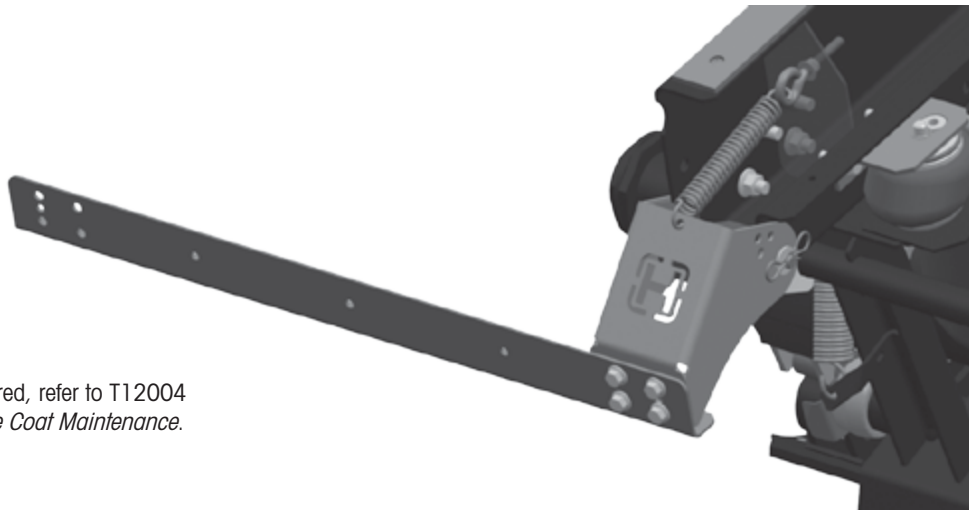

NOTE: If required, refer to T12004 *Surface Coat Maintenance*.

Mirror and repeat the above procedures for the opposing curbside bracket.

Call your trailer dealer or Hendrickson at **866.RIDEAIR (743.3247)** for additional information.



www.hendrickson-intl.com

TRAILER COMMERCIAL VEHICLE SYSTEMS

2070 Industrial Place SE
Canton, OH 44707-2641 USA
866.RIDEAIR (743.3247)
330.489.0045 • Fax 800.696.4416

Hendrickson Canada

250 Chrysler Drive, Unit #3
Brampton, ON Canada L6S 6B6
800.668.5360
905.789.1030 • Fax 905.789.1033

Hendrickson Mexicana

Circuito El Marqués Sur #29
Parque Industrial El Marqués
Pob. El Colorado, Municipio El Marqués,
Querétaro, México C.P. 76246
+52 (442) 296.3600 • Fax +52 (442) 296.3601