

# BRAKE CHAMBER INSTALLATION

AIR CONNECTION: 3/8-18 NPTF

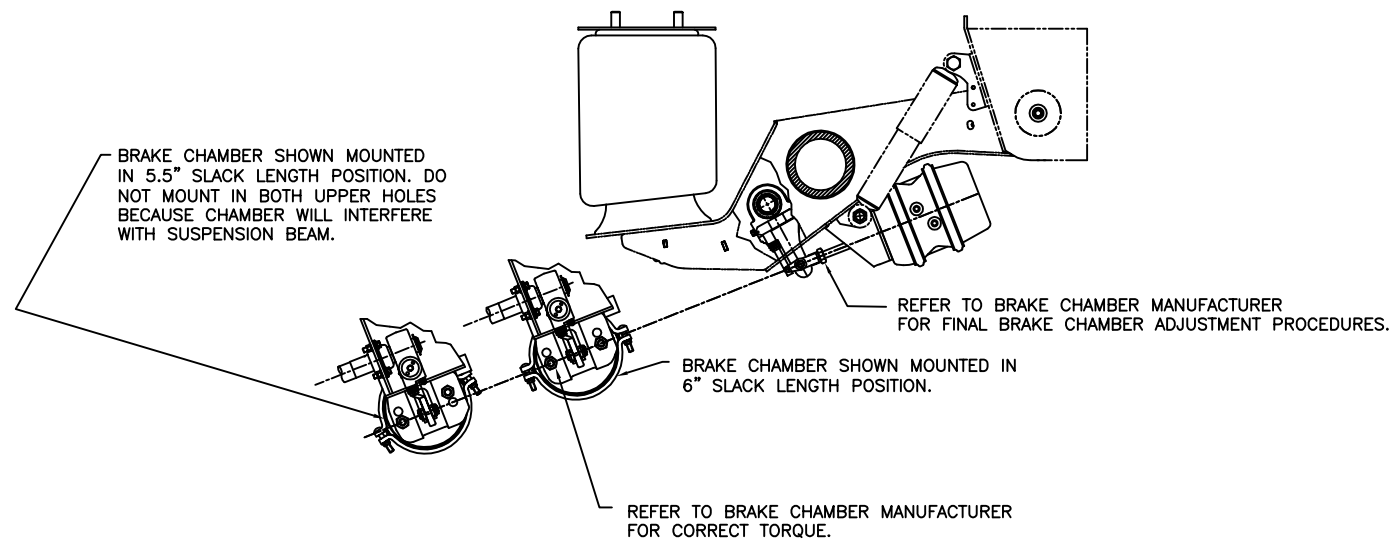

# SLACK ADJUSTER INSTALLATION

REFER TO SLACK ADJUSTER MANUFACTURER FOR INSTALLATION AND FINAL ADJUSTMENT FOR ALL SLACK ADJUSTERS THAT ARE NOT INSTALLED BY HENDRICKSON.

# HALDEX SLACK ADJUSTER INSTALLATION

REFER TO SLACK ADJUSTER MANUFACTURER FOR INSTALLATION AND FINAL ADJUSTMENT FOR ALL SLACK ADJUSTERS THAT ARE NOT INSTALLED BY HENDRICKSON.

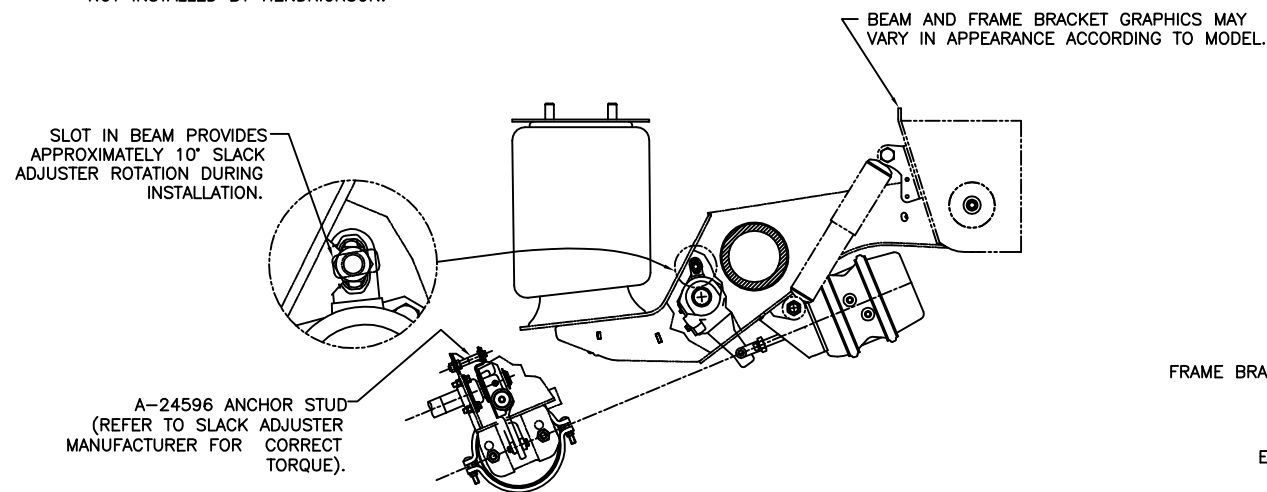

BRAKE CHAMBER ROD LENGTH		
MODEL	A	B
AANT, AAT, HKANT & HKAT	9.8	11.1
AANL, AANLS, AAL, AAEDL, AAEDT, HKANL, HKAL, & HKARL	5.6	7.0

VIEW AA  
SCALE: 1:66=1:000

# DOWN STOP INSTALLATION

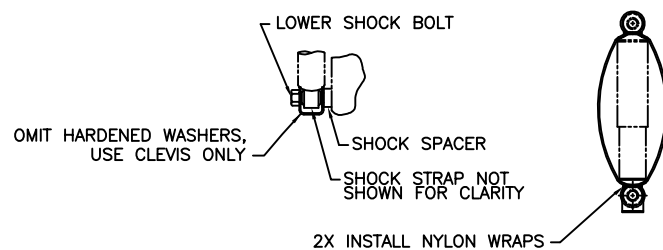
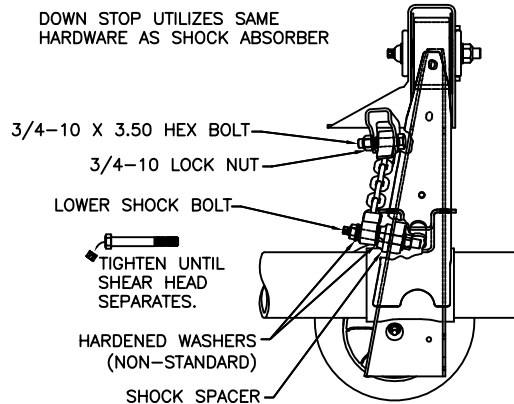

# OPTIONAL SHOCK STRAP INSTALLATION

# PIVOT BOLT INSTALLATION

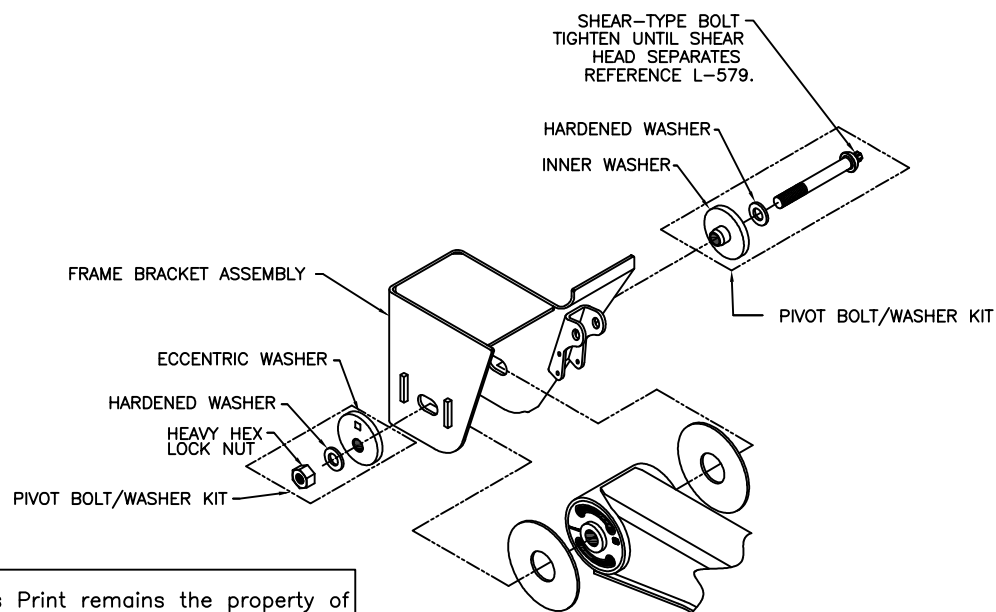

This Print remains the property of Hendrickson. All information contained thereon is confidential. It is loaned, subject to return on demand and on express condition that it is not to be copied or used directly or indirectly for any purpose other than the purpose for which it has been loaned to you.

TORQUE SPECIFICATIONS		
DESCRIPTION	SIZE	TORQUE (FT-LB)
AIR SPRING NUTS, UPPER	3/4-16	80-100
AIR SPRING NUT, LOWER	1/2-13	55-60
SHOCK BOLTS, UPPER	3/4-10	210-235

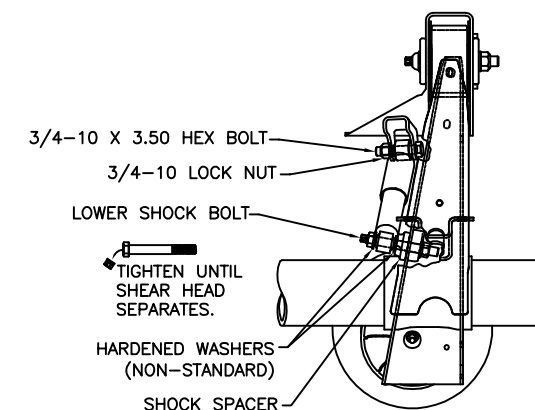

# O.E.M. INSTALLED SHOCK BOLT KIT

# AIR SPRING MOUNTING KIT (WITH SPACER)

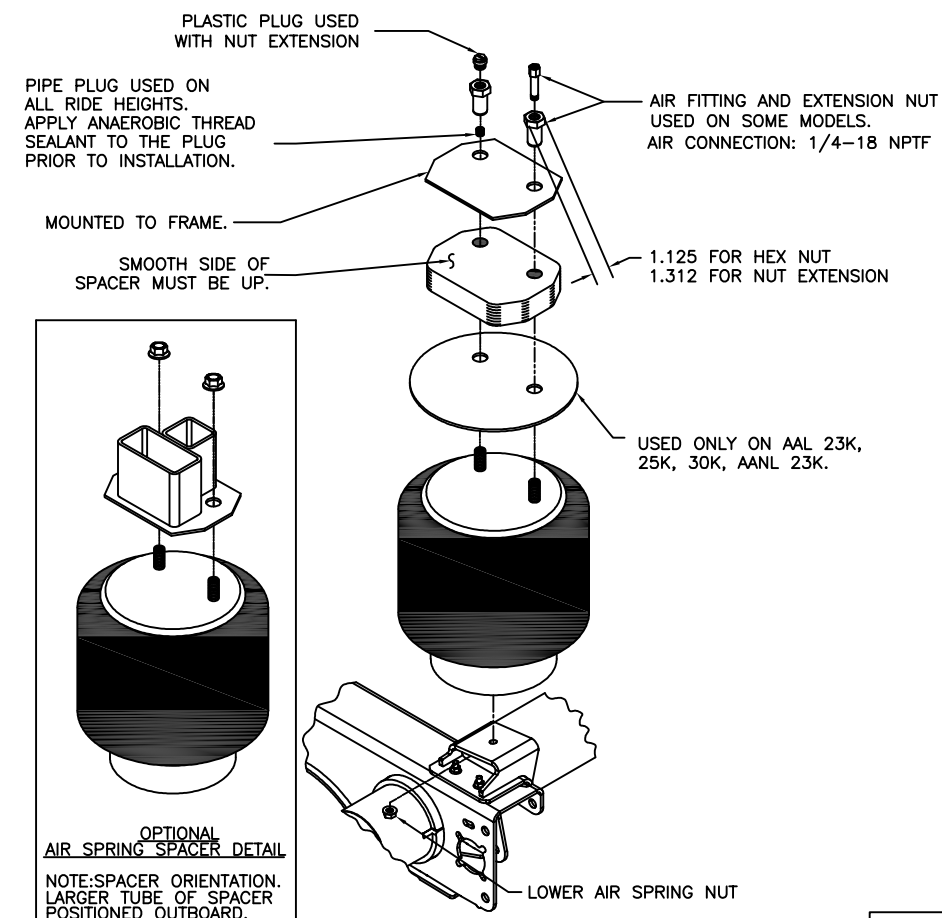

H. HENDRICKSON

TRAILER COMMERCIAL VEHICLE SYSTEMS  
2870 INDUSTRIAL PLACE S.E., CLEVELAND, OH 44135-0001 U.S.A.

UNLESS OTHERWISE NOTED: TOLERANCES ARE: X: ± .1 XX: ± .06 XXX: ± .030 ANGULAR: ± 0.5°	DIMENSIONS ARE: INCHES 15 14 13	16 34014 22070 21735	D/D DAG JEA	07/29/20 11/30/17 7-12-13 11-16-12	DRWN BY R.A.G.	04-30-99
DIMENSIONS ADHERE TO ANSI Y14.5M-1982 REV. EDCN NO. BY DATE			13 21735 JEA 11-16-12	DAUGHTERY	THIS DRAWING IS THE CONFIDENTIAL PROPERTY OF HENDRICKSON	

COMMON COMPONENT INSTALLATIONS

SCALE: 1:25=1:000  
D  
1 OF 1  
D-25266