

FOR MAXIMUM

STABILITY

AND

REDUCED

WEIGHT.

**HRS SERIES**  
Rubber Load Cushion

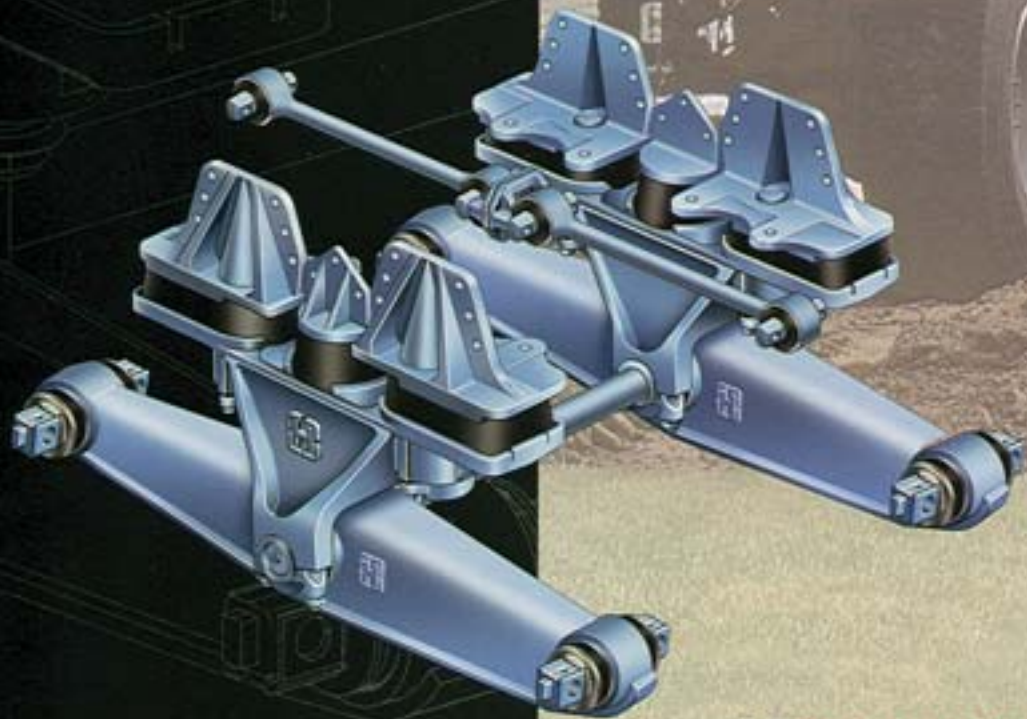

*For The Road Ahead*

**H HENDRICKSON**

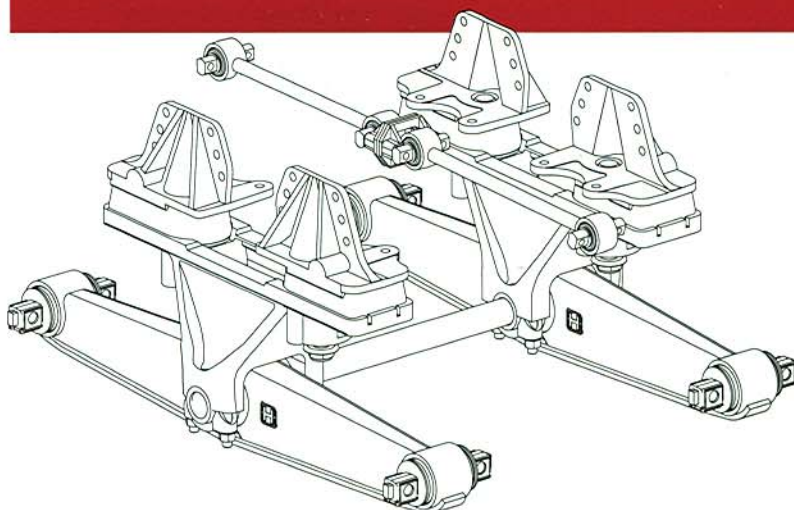

The RS Series, with specially formulated rubber load cushions, is engineered to maximize payload in high center-of-gravity and offset-load applications.

SUSPENSION SPECIFICATIONS

MODEL	BEAM TYPE <sup>1</sup>	INSTALLED WEIGHT <sup>2</sup>	SUSPENSION RATING	GW	GCW	WHEEL BASE RESTRICTIONS	SITE TRAVEL RATING <sup>3</sup>	ARTICULATION	LIFT AXLES	AXLE SPACING
RS 403	FAB BEAM	1,030 LBS.	40,000 LBS.	73,000	160,000	NONE	55,000 LBS.	15"	YES	52", 54", 56", 60", 72.5"
RS 463	FAB BEAM	1,086 LBS.	46,000 LBS.	80,000	190,000	NONE	60,000 LBS.	15"	YES	52", 54", 56", 60", 72.5"
RS 503	FORGED	1,175 LBS.	50,000 LBS.	80,000	225,000	NONE	65,000 LBS.	15"	YES	52", 54", 56", 60", 72.5"
RS 523	FORGED	1,225 LBS.	52,000 LBS.	80,000	245,000	NONE	65,000 LBS.	15"	YES	52", 54", 56", 60", 72.5"

<sup>1</sup> Beam Type: Fabricated beam on 40,000 lbs. to 46,000 lbs. at 52", 54", 60", 72.5" axle spacing and 50,000 lbs. to 52,000 lbs. at 72.5" axle spacing. Cast beam on 40,000 lbs. to 52,000 lbs. at 56" axle spacing, 50,000 lbs. to 52,000 lbs. at 52" axle spacing, and forged beam at 54" and 60" axle spacing. Based on standard 54" axle spacing.

<sup>2</sup> Installed Weight: Includes complete suspension, torque rods, axle brackets, and frame brackets. Based on standard 54" axle spacing.

<sup>3</sup> Site Travel Rating: Operators using vehicles equipped with liftable tag or pusher axles must not exceed published ratings. Ratings are limited to no more than 5% of vehicle operation at speed not to exceed 5 mph. Liftable tag or pusher axles should only be raised (or unloaded) to improve vehicle maneuverability in off-road use or when vehicle is unloaded. Site travel ratings are consistent with published axle manufacturer's limitations. Axle and suspension site travel ratings cannot be exceeded.

### The RS Series Delivers...

- **Great Durability and Reliability:** Fabricated beams are robotically welded to create a strong, reliable box structure, and a superior strength-to-weight ratio. Hangers are constructed of rugged, tough heavy-duty steel.
- **Maximized Payloads:** A rugged cast aluminum saddle and fabricated beam (40,000-lb. to 46,000-lb. capacity) saves weight.
- **Superior Stability Under All Conditions:** The walking beam design provides a high degree of traction on punishing job sites. Longitudinal rubber bushed torque rods prevent axle rotation during acceleration and braking. Transverse torque rods improve handling during cornering. (Recommended for refuse or severe service operations. Standard with axle spacings of 60" or more.) A Rebound Control Stop provides severe service and high center-of-gravity vehicles with a crucial level of ride control.
- **Extended Service Life/Reduced Maintenance:** Specially formulated high confinement center bushing lasts longer; so fewer rebushings are needed. Bar pin beam end connection also extends service life—and its axle alignment capability increases tire life. Center and end bushings (rubber for 40,000-lb. to 52,000-lb. capacities; bronze for 46,000-lb. to 52,000-lb. capacities) are specifically chosen for cost-effective long life.
- **More Sizes, Higher Capacities to Meet More Requirements:** RS Series is available with 52", 54", 56", 60", and 72.5" equalizing beams; rated capacities range up to 120,000 lbs. For higher capacity, contact Hendrickson application engineering.
- **Application Versatility:** RS is designed for on-highway, on/off-highway severe service operations including ready-mix, refuse, or logging.
- **Ideal For Lift Axle-Equipped Vehicles.**

