



H TECHNICAL PROCEDURE

SOFTEK® Front Suspension Systems for Lion Electric Lion8 Model Trucks

SUBJECT: Service Instructions

LIT NO: 17730-332

DATE: May 2020

REVISION: A

TABLE OF CONTENTS

Section 1	Introduction	2	Section 9	Component Replacement	
Section 2	Product Description	2		Fasteners	34
Section 3	Important Safety Notice	4		Front Leaf Spring Eye Bushings	34
Section 4	Parts Lists	8		Frame Hanger	34
Section 5	Special Tools	11		Rear Shackle Bracket	35
Section 6	Towing Procedure	12		Rubber Axle Stop	35
Section 7	Preventive Maintenance			Leaf Spring Assembly	36
	Hendrickson Recommended			STEERTEK NXT Axle	39
	Inspection Intervals	14		Steering Knuckle	42
	Component Inspection	14		Kingpin	43
	Lubrication Intervals	15		Kingpin Bushing	45
	Kingpin Lubrication	16		Tie Rod End and Cross Tube	51
	Tie Rod End	17		Air Disc Brakes	52
	Clamp Group Re-Torque Interval	19	Section 10	Front Wheel Alignment Specifications . 53	
	Surface Paint Wear Inspection	20	Section 11	Torque Specifications	54
	Kingpin Bushing	21	Section 12	Troubleshooting Guide	56
	Steering Knuckle	21	Section 13	Reference Material	58
	Shock Absorber	22			
	Tire Inspection	23			
	Brakes and Wheel Bearing End Play	25			
Section 8	Alignment & Adjustments				
	Alignment Definitions	26			
	Inspection Prior to Alignment	29			
	Front Wheel Alignment	29			
	Steering Stop	31			
	Toe Setting	32			
	Spring Eye Re-Torque	33			

SECTION 1

Introduction

This publication is intended to acquaint and assist maintenance personnel in the preventive maintenance, service, repair and rebuild of the following Hendrickson equipment as installed on applicable Lion Electric Lion8 Model Trucks:

SOFTEK® is an integrated front mechanical suspension with a durable, lightweight, fabricated STEERTEK NXT axle system.

NOTE

Use only Hendrickson Genuine parts for servicing this suspension system.

It is important to read and understand the entire Technical Procedure publication prior to performing any maintenance, service, repair, or rebuild of the product. The information in this publication contains parts lists, safety information, product specifications, features, proper maintenance, service, repair and rebuild instructions for the SOFTEK suspension with the STEERTEK NXT axle.

Hendrickson reserves the right to make changes and improvements to its products and publications at any time. Contact Hendrickson Tech Services for information on the latest version of this manual at 1-866-755-5968 (toll-free U.S. and Canada), 1-630-910-2800 (outside U.S. and Canada) or email: techservices@hendrickson-intl.com.

The latest revision of this publication is also available online at www.hendrickson-intl.com.

SECTION 2

Product Description

SOFTEK — is a front mechanical suspension and steer axle system that works to form an integrated torsion system. Utilizing a system approach, Hendrickson has engineered and optimized the following components to form a system delivering ride, stability and handling characteristics with reduced weight and maintenance.

Leaf spring assembly — With its innovative design, the leaf spring provides superior stability, performance and a soft ride. Durable rubber bushings are greaseless and only require periodic inspections.

Shock absorbers — SOFTEK utilizes premium shocks that have been tested and tuned specifically for the suspension system.

Frame brackets — Optimized design delivers weight reduction and proven durability.

STEERTEK NXT — The box-shaped cross section resists horizontal, vertical and twisting forces. Continuous beam architecture minimizes stress points for added durability.

Axle Clamp Group — The Clamp Group consists of the top pad, U-bolts, washers, and nylon locknuts

Integrated Axle Seats — Integrated axle seats to improve ground clearance, reduce part count, and simplify assembly.

Adjustable Tie Rod — To help maximize tire life, the tie rod easily adjusts toe-in/out.

Steering Knuckles — The steering and tie rod arms are integrated for increased strength and reduced weight. The unique steering knuckle packaging delivers up to a maximum of 50° wheel cut. The two piece knuckle design makes replacing the kingpin bushings easier by eliminating the need to remove the kingpins.

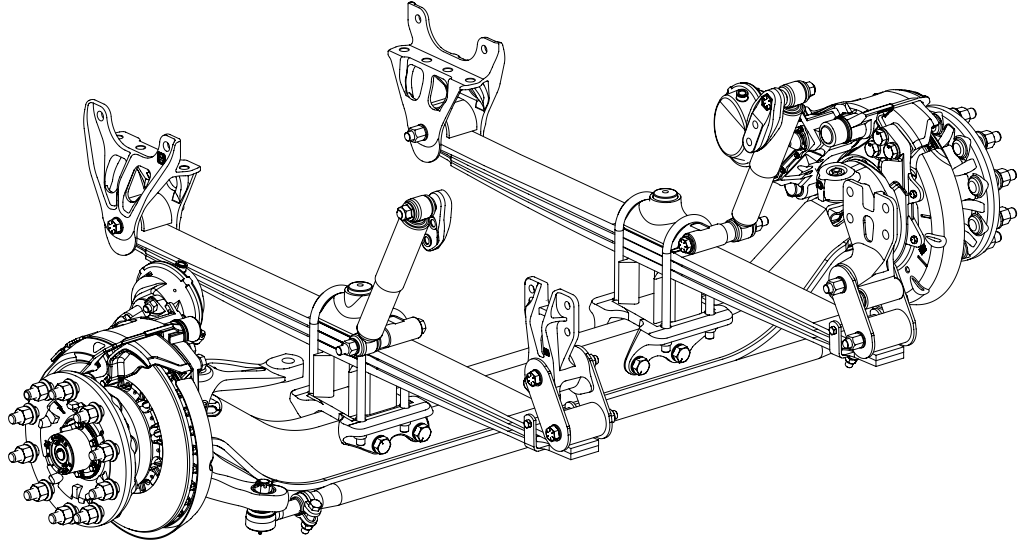
FIGURE 2-1

TECHNICAL NOTES

1. SOFTEK is approved for on-highway use; other applications must be pre-approved by Hendrickson Sales Engineering. This system has a 14,600 pound capacity. System capacity rating for the suspension represents maximum loads on tires at ground level.
2. The STEERTEK NXT axle is also available with 71" kingpin intersection (KPI) for the Lion8 Model Trucks.
4. SOFTEK suspension weight includes frame and shackle bracket assemblies, steel leaf springs, bushings, shocks, upper shock brackets and axle clamp group.
5. STEERTEK NXT axle weight includes the axle beam, knuckle/steering arm assemblies and tie rod assemblies.
6. SOFTEK is integral to and available exclusively with the STEERTEK NXT axle. This system is anti-lock braking system (ABS) ready. STEERTEK NXT is compatible with most industry standard wheel ends and brakes. Contact OEM for more information.
7. The STEERTEK NXT axle product identification is etched on the center front of the axle beam providing the following information:
 - Axle part number: Identifies the features of the axle beam.
 - Axle assembly number: Identifies the complete assembly, which includes the steering knuckles, bracket assemblies and tie rod assemblies

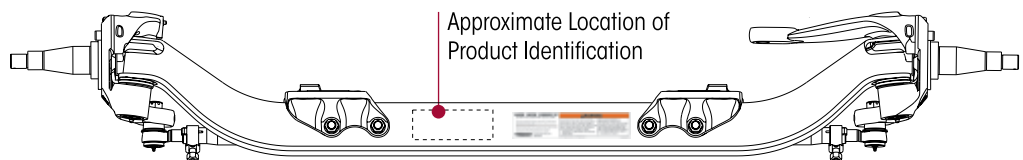
FIGURE 2-2 Front view of the axle showing approximate location of product identification.

SECTION 3

Important Safety Notice

Proper maintenance, service and repair is important to the reliable operation of the suspension. The procedures recommended by Hendrickson and described in this technical publication are methods of performing such maintenance, service and repair.

The warnings and cautions should be read carefully to help prevent personal injury and to assure that proper methods are used. Improper maintenance, service or repair may damage the vehicle, cause personal injury, render the vehicle unsafe in operation, or void manufacturer's warranty.

Failure to follow the safety precautions in this manual can result in personal injury and/or property damage. Carefully read and understand all safety related information within this publication, on all decals and all such materials provided by the vehicle manufacturer before conducting any maintenance, service or repair.

EXPLANATION OF SIGNAL WORDS

Hazard "Signal Words" (Danger-Warning-Caution) appear in various locations throughout this publication. Information accented by one of these signal words must be observed to help minimize the risk of personal injury to service personnel, or possibility of improper service methods which may damage the vehicle or render it unsafe.



This is the safety alert symbol. It is used to alert you to potential personal injury hazards. Obey all safety messages that follow this symbol to avoid possible injury or death.

Additional 'Notes' or 'Service Hints' are utilized to emphasize areas of procedural importance and provide suggestions for ease of repair. The following definitions indicate the use of these signal words as they appear throughout the publication.



INDICATES AN IMMINENTLY HAZARDOUS SITUATION WHICH, IF NOT AVOIDED, WILL RESULT IN SERIOUS INJURY OR DEATH.



INDICATES A POTENTIAL HAZARDOUS SITUATION WHICH, IF NOT AVOIDED, CAN RESULT IN SERIOUS INJURY OR DEATH.



INDICATES A POTENTIAL HAZARDOUS SITUATION WHICH, IF NOT AVOIDED, MAY RESULT IN MINOR OR MODERATE INJURY, OR PROPERTY DAMAGE.

NOTE

An operating procedure, practice condition, etc. which is essential to emphasize.

SERVICE HINT

A helpful suggestion, which will make the servicing being performed a little easier and/or faster.

Also note that particular service operations may require the use of special tools designed for specific purposes. These special tools can be found in the Special Tools Section of this publication.



The torque symbol alerts you to tighten fasteners to a specified torque value. Refer to Torque Specifications Section of this publication.

SAFETY PRECAUTIONS



LOAD CAPACITY

ADHERE TO THE PUBLISHED CAPACITY RATINGS FOR THE SUSPENSIONS. ADD-ON AXLE ATTACHMENTS (I.E. SLIDING FIFTH WHEELS) AND OTHER LOAD TRANSFERRING DEVICES CAN INCREASE THE SUSPENSION LOAD ABOVE THE RATED AND APPROVED CAPACITIES WHICH COULD RESULT IN FAILURE AND LOSS OF VEHICLE CONTROL, POSSIBLY CAUSING PERSONAL INJURY OR PROPERTY DAMAGE.



WARNING

FASTENERS

DISCARD USED FASTENERS. ALWAYS USE NEW FASTENERS TO COMPLETE A REPAIR. FAILURE TO DO SO COULD RESULT IN FAILURE OF THE PART, OR MATING COMPONENTS, LOSS OF VEHICLE CONTROL, PERSONAL INJURY, OR PROPERTY DAMAGE.

LOOSE OR OVER TORQUED FASTENERS CAN CAUSE COMPONENT DAMAGE, LOSS OF VEHICLE CONTROL, PROPERTY DAMAGE, OR SEVERE PERSONAL INJURY. MAINTAIN CORRECT TORQUE VALUE AT ALL TIMES. CHECK TORQUE VALUES ON A REGULAR BASIS AS SPECIFIED, USING A TORQUE WRENCH THAT IS REGULARLY CALIBRATED. TORQUE VALUES SPECIFIED IN THIS TECHNICAL PUBLICATION ARE FOR HENDRICKSON SUPPLIED FASTENERS ONLY. IF NON HENDRICKSON FASTENERS ARE USED, FOLLOW TORQUE SPECIFICATION LISTED IN THE VEHICLE MANUFACTURER'S SERVICE MANUAL.

WARNING

REPAIR OR RECONDITIONING

THE REPAIR OR RECONDITIONING OF SUSPENSION OR AXLE COMPONENTS IS NOT ALLOWED AS SHOWN ON LABEL IN FIGURE 3-1 . ANY AXLE COMPONENTS FOUND TO BE DAMAGED OR OUT OF SPECIFICATIONS MUST BE REPLACED. ALL MAJOR HENDRICKSON COMPONENTS ARE HEAT TREATED AND TEMPERED. SOFTEK COMPONENTS CANNOT BE BENT, WELDED, HEATED, OR REPAIRED WITHOUT REDUCING THE STRENGTH OR LIFE OF THE COMPONENT. FAILURE TO FOLLOW THESE GUIDELINES CAN CAUSE LOSS OF VEHICLE CONTROL, POSSIBLE PERSONAL INJURY, DEATH, OR PROPERTY DAMAGE AND WILL VOID APPLICABLE WARRANTIES.

WARNING

SHOCK ABSORBERS

THE SHOCK ABSORBERS ARE THE REBOUND TRAVEL STOPS FOR THE LEAF SPRINGS. ANYTIME THE FRONT AXLE ON AN SOFTEK SUSPENSION IS SUSPENDED IT IS MANDATORY THAT THE SHOCK ABSORBERS REMAIN CONNECTED. FAILURE TO DO SO COULD CAUSE THE LEAF SPRINGS TO EXCEED THEIR MAXIMUM LENGTH, OR CAUSE A REVERSE ARCH IN THE STEEL LEAF SPRINGS, POSSIBLY RESULTING IN PREMATURE STEEL LEAF SPRING FAILURE.

WARNING

MODIFYING COMPONENTS

DO NOT MODIFY OR REWORK PARTS WITHOUT AUTHORIZATION FROM HENDRICKSON. DO NOT SUBSTITUTE REPLACEMENT COMPONENTS NOT AUTHORIZED BY HENDRICKSON. USE OF MODIFIED, REWORKED, SUBSTITUTE OR REPLACEMENT PARTS NOT AUTHORIZED BY HENDRICKSON MAY NOT MEET HENDRICKSON'S SPECIFICATIONS, AND CAN RESULT IN FAILURE OF THE PART, LOSS OF VEHICLE CONTROL, POSSIBLE PERSONAL INJURY OR PROPERTY DAMAGE, AND WILL VOID ANY APPLICABLE WARRANTIES. USE ONLY HENDRICKSON AUTHORIZED REPLACEMENT PARTS.

CAUTION

PROCEDURES AND TOOLS

A TECHNICIAN USING A SERVICE PROCEDURE OR TOOL WHICH HAS NOT BEEN RECOMMENDED BY HENDRICKSON MUST FIRST SATISFY HIMSELF THAT NEITHER HIS SAFETY NOR THE VEHICLE'S SAFETY WILL BE JEOPARDIZED BY THE METHOD OR TOOL SELECTED. INDIVIDUALS DEVIATING IN ANY MANNER FROM THE INSTRUCTIONS PROVIDED ASSUME ALL RISKS OF POTENTIAL PERSONAL INJURY OR DAMAGE TO EQUIPMENT INVOLVED.

WARNING

SUPPORT THE VEHICLE PRIOR TO SERVICING

PLACE THE VEHICLE ON A LEVEL FLOOR AND CHOCK THE WHEELS TO HELP PREVENT THE VEHICLE FROM MOVING. NEVER WORK UNDER A RAISED VEHICLE SUPPORTED ONLY BY A FLOOR JACK. ALWAYS SUPPORT A RAISED VEHICLE WITH SAFETY STANDS. CHOCK THE WHEELS AND MAKE SURE THE VEHICLE WILL NOT ROLL PRIOR TO RELEASING THE BRAKES. A FLOOR JACK CAN SLIP OR FALL OVER. SERIOUS PERSONAL INJURY CAN RESULT.

AXLE CAMBER IS NOT ADJUSTABLE. DO NOT CHANGE THE AXLE CAMBER ANGLE OR BEND THE AXLE BEAM, SEE FIGURE 3-1 . BENDING THE AXLE BEAM TO CHANGE THE CAMBER ANGLE CAN DAMAGE THE AXLE AND REDUCE AXLE STRENGTH, WILL VOID HENDRICKSON'S WARRANTY AND CAN CAUSE LOSS OF VEHICLE CONTROL, POSSIBLY CAUSING PERSONAL INJURY OR PROPERTY DAMAGE.

WARNING**AXLE CAMBER**

UNAUTHORIZED WELDING OR MODIFICATIONS CAN CAUSE CRACKS OR OTHER AXLE STRUCTURAL DAMAGE AND RESULT IN LOSS OF VEHICLE CONTROL, SEVERE PERSONAL INJURY OR DEATH. DO NOT BEND, WELD OR MODIFY AXLE WITHOUT AUTHORIZATION FROM HENDRICKSON TRUCK COMMERCIAL VEHICLE SYSTEMS.

WARNING**AXLE KINGPINS**

STEERTEK NXT / STEERTEK IS A UNIQUE AXLE, IN THAT THE KINGPIN IS CRYOGENICALLY INSTALLED IN THE AXLE. THE KINGPIN IS A NON-REPLACEABLE COMPONENT OF THE AXLE ASSEMBLY. DO NOT TRY TO REMOVE THE KINGPIN. IF THE KINGPIN OR ADJACENT MATING SURFACE SHOW SIGNS OF DAMAGE OR MOVEMENT, DO NOT OPERATE THE VEHICLE AND IMMEDIATELY CONTACT THE HENDRICKSON TECH SERVICES DEPARTMENT.

WARNING**STEERTEK NXT AXLE SPRING SEATS**

THE INTEGRATED AXLE SPRING SEATS ON THE STEERTEK NXT AXLE ARE NON-SERVICEABLE. UNAUTHORIZED TAMPERING OF INTEGRATED AXLE SPRING SEATS CAN CAUSE COMPONENT AND STRUCTURAL DAMAGE AND RESULT IN LOSS OF VEHICLE CONTROL, SEVERE PERSONAL INJURY OR DEATH, PROPERTY DAMAGE, AND WILL VOID ANY APPLICABLE WARRANTY. DO NOT REMOVE, MODIFY OR REPLACE INTEGRATED AXLE SPRING SEAT OR FASTENERS, SEE FIGURE 3-1.

NOTE: REPLACE ANY SAFETY DECALS THAT ARE FADED, TORN, MISSING, ILLEGIBLE, OR OTHERWISE DAMAGED. CONTACT HENDRICKSON TO ORDER REPLACEMENT LABELS.

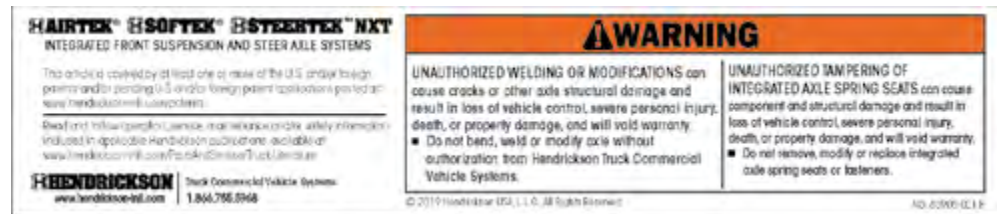
FIGURE 3-1**WARNING****DAMAGED AXLE COMPONENTS**

IF A VEHICLE EQUIPPED WITH A STEERTEK NXT / STEERTEK AXLE IS INVOLVED IN A CRASH, THE AXLE STEER KNUCKLES MUST BE DISASSEMBLED AND A THOROUGH INSPECTION OF THE AXLE MUST BE PERFORMED NOTING THE CONDITION OF THE AXLE BEAM, KINGPINS, AND KNUCKLE ASSEMBLIES, INCLUDING THE AREAS OF AXLE TO KINGPIN INTERFACE FOR ANY DAMAGE, GAPS, KINGPIN MOVEMENT OR PLAY. IF ANY COMPONENT APPEARS DAMAGED, OR THE KINGPINS APPEAR TO CONTAIN ANY DAMAGE, GAPS, MOVEMENT OR PLAY, THE COMPLETE AXLE ASSEMBLY MUST BE REPLACED.

IN ADDITION, IN THE EVENT A CRASH RESULTS IN EXCESSIVE SIDE LOAD DAMAGE TO ADJACENT PARTS, SUCH AS A BENT WHEEL, HUB, OR SPINDLE, IT IS STRONGLY RECOMMENDED TO REPLACE THE COMPLETE AXLE ASSEMBLY.

CONTACT HENDRICKSON TECHNICAL SERVICES WITH ANY QUESTIONS. FAILURE TO REPLACE ANY DAMAGED COMPONENTS CAN CAUSE LOSS OF VEHICLE CONTROL, POSSIBLE PERSONAL INJURY, DEATH, OR PROPERTY DAMAGE AND WILL VOID ANY APPLICABLE WARRANTIES.

WARNING**SUPPORT THE VEHICLE PRIOR TO SERVICING**

PLACE THE VEHICLE ON A LEVEL FLOOR AND CHOCK THE WHEELS TO HELP PREVENT THE VEHICLE FROM MOVING. NEVER WORK UNDER A RAISED VEHICLE SUPPORTED ONLY BY A FLOOR JACK. ALWAYS SUPPORT A RAISED VEHICLE WITH SAFETY STANDS. CHOCK THE WHEELS AND MAKE SURE THE VEHICLE WILL NOT ROLL PRIOR TO RELEASING THE BRAKES. A FLOOR JACK CAN SLIP OR FALL OVER. SERIOUS PERSONAL INJURY CAN RESULT.

WARNING**TORCH/WELDING**

DO NOT USE A CUTTING TORCH TO REMOVE ANY FASTENERS. THE USE OF HEAT ON SUSPENSION COMPONENTS WILL ADVERSELY AFFECT THE STRENGTH OF THESE PARTS. A COMPONENT DAMAGED IN THIS MANNER CAN RESULT IN THE LOSS OF VEHICLE CONTROL AND POSSIBLE PERSONAL INJURY OR PROPERTY DAMAGE.

EXERCISE EXTREME CARE WHEN HANDLING OR PERFORMING MAINTENANCE IN THE AREA OF THE SPRING ASSEMBLY AND AXLE. DO NOT CONNECT ARC WELDING GROUND LINE TO THE SPRING ASSEMBLY OR AXLE. DO NOT STRIKE AN ARC WITH THE ELECTRODE ON THE SPRING ASSEMBLY OR AXLE. DO NOT USE HEAT NEAR THE SPRING ASSEMBLY OR AXLE. DO NOT NICK OR GOUGE THE SPRING ASSEMBLY OR AXLE. SUCH IMPROPER ACTIONS CAN CAUSE DAMAGE TO THE SPRING ASSEMBLY OR THE AXLE COULD FAIL, AND CAN CAUSE LOSS OF VEHICLE CONTROL AND POSSIBLE PERSONAL INJURY OR PROPERTY DAMAGE.

WARNING**PERSONNEL PROTECTIVE EQUIPMENT**

ALWAYS WEAR PROPER EYE PROTECTION AND OTHER REQUIRED PERSONAL PROTECTIVE EQUIPMENT TO HELP PREVENT PERSONAL INJURY WHEN PERFORMING VEHICLE MAINTENANCE, REPAIR OR SERVICE.

WARNING**OFF-ROADWAY TOWING**

WHEN A VEHICLE IS DISABLED AND EQUIPPED WITH A STEERTEK NXT AXLE, CARE MUST BE TAKEN TO ENSURE THERE IS NO DAMAGE TO THE SUSPENSION OR AXLE WHEN TOWING THE VEHICLE. THE USE OF A TOW STRAP IS NECESSARY TO TOW A DISABLED VEHICLE TO A REPAIR FACILITY PARKING LOT INTO THE SHOP BAY. THE TOW STRAPS SHOULD BE CONNECTED TO THE TOW HOOKS PROVIDED BY THE VEHICLE MANUFACTURER AT THE FRONT OF THE BUMPER. IF THE USE OF TOW HOOKS IS NOT AN OPTION, THEN A TOW STRAP MAY BE WRAPPED AROUND THE FRONT AXLE, (SEE FIGURE 3-2) IN A MANNER THAT IS ACCEPTABLE FOR TOWING THE VEHICLE FROM A REPAIR FACILITY PARKING LOT INTO THE SHOP BAY. DO NOT USE A TOW CHAIN AROUND THE FRONT AXLE OR WITH A SINGLE POINT LOCATION TO TOW THE VEHICLE. DOING SO WILL DAMAGE THE AXLE AND VOID ANY APPLICABLE WARRANTY, SEE FIGURE 3-2. FOR DETAILED TOWING INSTRUCTIONS FOR ON-HIGHWAY TOWING, SEE TOWING PROCEDURES SECTION IN THIS PUBLICATION.

FIGURE 3-2**OFF-ROADWAY TOWING****WARNING****PARTS CLEANING**

SOLVENT CLEANERS CAN BE FLAMMABLE, POISONOUS AND CAUSE BURNS. TO HELP AVOID SERIOUS PERSONAL INJURY, CAREFULLY FOLLOW THE MANUFACTURER'S PRODUCT INSTRUCTIONS AND GUIDELINES AND THE FOLLOWING PROCEDURE:

1. WEAR PROPER EYE PROTECTION
2. WEAR CLOTHING THAT PROTECTS YOUR SKIN
3. WORK IN A WELL VENTILATED AREA
4. DO NOT USE GASOLINE, OR SOLVENTS THAT CONTAIN GASOLINE. GASOLINE CAN EXPLODE
5. HOT SOLUTION TANKS OR ALKALINE SOLUTIONS MUST BE USED CORRECTLY. FOLLOW THE MANUFACTURER'S RECOMMENDED INSTRUCTIONS AND GUIDELINES CAREFULLY TO HELP PREVENT PERSONAL ACCIDENT OR INJURY

DO NOT USE HOT SOLUTION TANKS OR WATER AND ALKALINE SOLUTIONS TO CLEAN GROUND OR POLISHED PARTS. DOING SO WILL CAUSE DAMAGE TO THE PARTS AND VOID ANY APPLICABLE WARRANTY.

SECTION 4 Parts Lists

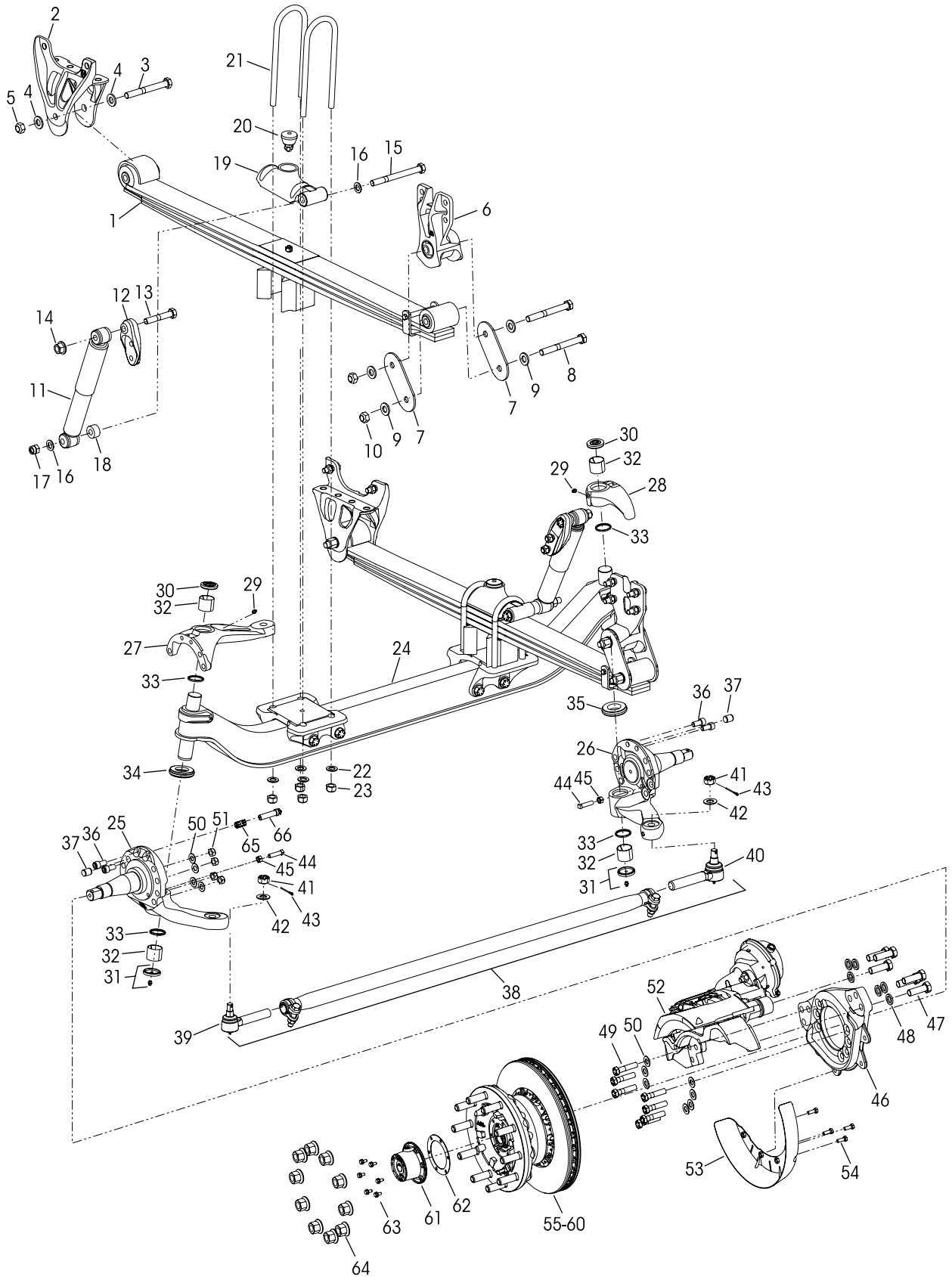



KEY NO.	PART NO.	DESCRIPTION	VEHICLE QTY.
1	82572-000	Leaf Spring Assembly	2
2	64488-002	Front Hanger	2
	34013-347	Front Spring Eye Fastener Service Kit, One Side, Includes Key Nos. 3-5	
3		*3/4"-16 UNF x 7" Hex Bolt	2
4		*3/4" Flat Washer	4
5		*3/4"-16 UNF Locknut	2
6	66510-001	Rear Shackle Bracket Assembly	2
7	64314-000	Rear Shackle Plate	4
	34013-348	Rear Shackle Bracket Fastener Service Kit, One Side, Includes Key Nos. 8-10	
8		*3/4"-16 UNF x 6 1/2" Hex Bolt	4
9		*3/4" Flat Washer	8
10		*3/4"-16 UNF Locknut	4
11	58913-010L	Shock Absorber	2
12	67463-002	Upper Shock Absorber Bracket	2
	34013-349	Single Shock Absorber Fastener Service Kit, Includes Key Nos. 13-18	
13	58917-022	3/4"-10 UNC x 4 1/2" Upper Shock Bolt	2
14	66137-000	3/4"-10 UNC Flange Locknut	2
15	58917-016	3/4"-10 UNC x 8 1/2" Lower Shock Bolt	2
16	22962-001	3/4" Flat Washer	4
17	49842-000	3/4"-10 UNC Hex Locknut	2
18	59946-001	Shock Spacer	2
	66806-001	Top Pad / Axle Stop Assembly, Includes Key Nos. 19-20	
19	66666-000	Top Pad	2
20	64080-000	Rubber Axle Stop	2
	34013-886	Clamp Group Fastener Service Kit, One Side, Includes Key Nos. 21-23	
21	64804-110	3/4"-16 UNC x 11" U-bolt	4
22	22962-001	3/4" Flat Washer	8
23	17700-035	3/4"-16 UNF Hex Locknut	8
	68987-022	STEERTEK NXT Axle Assembly Includes Key Nos. 24-45	1
24	68986-003M	Axle & Kingpin Assembly	1
		Lower Steering Knuckle Assembly, Includes Key Nos. 31-33, 37, 44-45	
25	58900-233	Left Hand	1
26	58900-234	Right Hand	1
		Upper Steering Knuckle Assembly, Includes Key Nos. 29-30, 32-33	
27	60903-255	Left Hand	1
28	60903-202	Right Hand	1
		Kingpin Bushing and Bearing Service Kits	
	60961-628	Axle Set, Includes Kit Nos. 60961-629 & -630	
	60961-629	Left Hand with Composite Thrust Bearing, Includes Key Nos. 29-34, 36 & Loctite	
	60961-630	Right Hand with Roller Thrust Bearing, Includes Key Nos. 29-33, 35-36 & Loctite	
29	33117-000	Grease Zerk	2
30	68687-003	Grease Cap Assembly, Upper	2
31	68687-002	Grease Cap Assembly, Lower	2
32	58909-001	Kingpin Bushing	4
		Thrust Bearing Service Kits	
	60961-631	Axle Set, Includes Kit Nos. 60961-632 & -633	
	60961-632	Left Hand Composite Thrust Bearing, Includes Key Nos. 33-34, 36 & Loctite	
	60961-633	Right Hand Roller Thrust Bearing, Includes Key Nos. 33, 35-36 & Loctite	

KEY NO.	PART NO.	DESCRIPTION	VEHICLE QTY.
33	68731-000	Kingpin Seal	4
34	59828-000	Left Hand Composite Thrust Bearing	1
35	64256-000L	Right Hand Roller Thrust Bearing	1
36	60236-001	5/8"-13 UNC Socket Head Cap Screw	4
Not Shown	60937-000	Loctite® (Red) Compound Tube	1
37	64246-000	ABS Sensor Sleeve	2
38	76879-002	Tie Rod Assembly, Straight, 4.25" Drop, Includes Key Nos. 39-41	1
		Tie Rod End Service Kits	
	60961-735	Axle Set, Includes Kit Nos. 60961-742 & -743	
	60961-742	Left Hand, Includes Key Nos. 39, 41-43	
	60961-743	Right Hand, Includes Key Nos. 40-43	
		Tie Rod End, Includes Key No. 41	
39	76876-001	Left Hand	1
40	76876-002	Right Hand	1
41		*7/8" Castle Nut	2
42	22962-007	7/8" Flat Washer	2
43	17800-004	Tie Rod Nut Cotter Pin	2
	60961-069	Stop Bolt Service Kit, One Side, Includes Key Nos. 44-45	
44		*1/2"-13 UNC Square Head Bolt	2
45		*1/2"-13 UNC Hex Jam Nut	2
46		**Bendix Torque Plate Left Hand Part No. K114006 Right Hand Part No. K114007	2
47	SA-13200-2	M20 x 2.5 x 60 mm Bolt (Caliper)	12
48	58246-007	M20 Flat Washer (Caliper)	12
49	32043-002	5/8"-11 UNC x 2 3/4" Hex Bolt (Torque Plate)	14
50	22962-036	5/8" Hardened Washer (Torque Plate)	22
51	47764-000	5/8"-11 UNC Locknut (Torque Plate)	8
52		**Bendix Brake Caliper Assembly Left Hand Part No. 802985 Right Hand Part No. 802984	2
53		**Bendix Dust Shield Part No. K123970	2
54	58035-001	3/8"-16 UNC x 1" Hex Bolt (Dust Shield)	8
		**Conmet® Pre-Set Hub and Rotor Assembly, Part No. 10083209, Includes Key Nos. 55-60	2
55		**Conmet Hub Bearing Rebuild Kit, Part No. 10081727	
56		**Conmet Inner Bearing Cup and Cone Assembly, Part No. 10041905	
57		**Conmet Outer Bearing Cup and Cone Assembly, Part No. 10041906	
58		**Conmet Wheel Seal and Spacer Kit, Part No. 10081518	
59		**Conmet Seal Kit, Part No. 10045885	
60		**Conmet Rotor Service Kit, Part No. 10082074	
61		**Stemco Hubcap Assembly - 6", Kit No. 343-4346, Includes Key No. 64	2
62		**Stemco Hubcap Gasket Part No. 330-3024	2
63	64545-002	5/16"-18 UNC x 3/4" Hex Bolt (Hubcap) with Retainer Washer	12
64		**M22 x 1.5 Two-piece Wheel Nut	20
65	64550-000	ABS Sensor Clip	2
66	A-22930-4	ABS Sensor	2



NOTES: * Item included in assembly only, part not sold separately.

** Not supplied by Hendrickson for aftermarket service purposes. Description and part number listed for reference only. For more information and assistance with service, maintenance and rebuild instructions on these components see below component manufacturers:

- **Bendix** 1-800-AIR-BRAKE, customer service option 1, Tech Team, option 2. Online part number support go to: www.bendix.com/en/servicesupport/partnumbersearch/partnumbersearch_1.jsp
Online technical support training go to: www.brake-school.com
- **Conmet** Technical and Part Support 800.547.9473 or go to www.conmet.com/general/literature, go to Wheel End Literature, scroll down to Service Manual, Lit No. 10084476
- **Stemco** Technical and Part Support 800.527.8492 or go to www.stemco.com

SECTION 5 Special Tools

KINGPIN BUSHING TOOL – ADJUSTABLE STRAIGHT FLUTE REAMER

The dimension of cutting diameter must facilitate a range of 1.802" – 1.812"



KINGPIN BUSHING AND SEAL SHOP MADE TOOLS

SHOP MADE TOOLS: These shop made tools are designed to install and remove kingpin bushings. Bushing tools are made from cold rolled steel or equivalent. Drawings are for reference only. Hendrickson does not supply these tools.

***Bushing Driver**

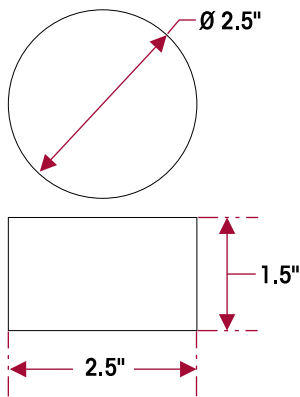

Bushing Receiving Tool
(for press bushing replacement)

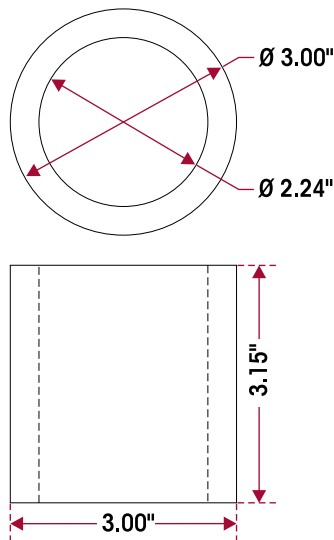

NOTE: *The bushing driver is necessary to sink the kingpin bushing flush into the steering knuckle bore.

NOTE: Kingpin Handle is used for both bushing installer / remover and seal installer tools

Kingpin Handle

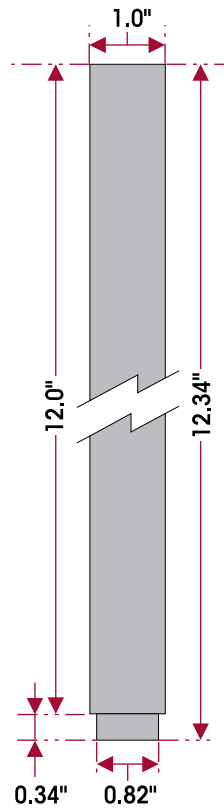

Bushing Installer / Remover Tool
(to seat bushing)

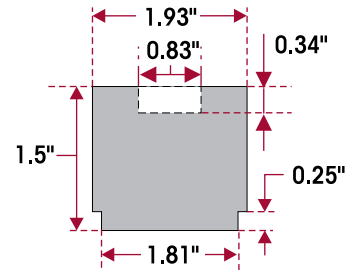

Seal Installer Tool
(to seat seal)

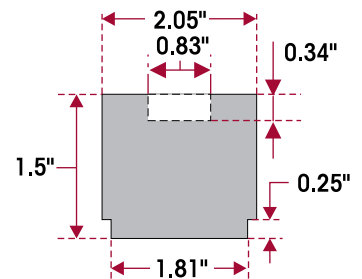

SECTION 6

Towing Procedure

ON-HIGHWAY AND ON-ROADWAY

Please read, understand and comply with any additional towing instructions and safety precautions that may be provided by the vehicle manufacturer.

Hendrickson will not be responsible for any damage to the axle, suspension or other vehicle components resulting from any towing method or fixture not authorized by Hendrickson.

Please contact Hendrickson Tech Services toll-free at 1-866-755-5968 (U.S. and Canada) or send e-mail to: techservices@hendrickson-intl.com with any questions regarding proper towing procedures for vehicles equipped with a STEERTEK NXT axle.

Hendrickson recommends that a vehicle equipped with a STEERTEK NXT axle be towed by the following methods (listed in order of preference) for ON-HIGHWAY or ON-ROADWAY applications.

- **METHOD 1** — Wheel lift, the ideal towing procedure
- **METHOD 2** — Towing the vehicle from the rear
- **METHOD 3** — Conventional axle fork

■ Method 1 — Wheel Lift

This method provides the greatest ease for towing the vehicle. Lifting at the tires helps reduce the risk of possible damage to the axle, suspension, and engine components during towing operations, see Figure 6-1.

FIGURE 6-1 Wheel lift method



■ Method 2 — Towing Vehicle from the Rear

This method is preferred when the proper equipment is not available to perform the wheel lift method and is necessary for wreckers not equipped with an under lift system.



■ **Method 3 — Conventional Axle FORK**

This is an alternative method for towing the vehicle, but requires standard tow forks, and designated lift points inside the STEERTEK NXT axle clamp groups.

NOTE

When lifting a vehicle with an under lift boom, care must be taken not to damage the engine's oil pan. Vehicles equipped with a front fairing may require removal of the front fairing prior to towing to prevent component damage.

- Ensure there is sufficient clearance between the oil pan and the boom
 - Release the tractor brakes
 - Install safety straps prior to towing the vehicle, it is preferred to use nylon safety straps. Chains have a tendency to bind and may cause damage to the axle.
1. Use a tow fork with a minimum of 4.5" Opening, 2" Shank, see Figure 6-2.
 2. Install the fork in the boom properly.
 3. The proper tow fork location is centered between the locknuts on the axle spring seats, see Figure 6-3.

FIGURE 6-2



FIGURE 6-3



OFF-ROADWAY TOWING METHOD



WHEN A VEHICLE IS DISABLED AND EQUIPPED WITH A STEERTEK NXT AXLE, CARE MUST BE TAKEN TO ENSURE THERE IS NO DAMAGE TO THE SUSPENSION OR AXLE WHEN TOWING THE VEHICLE. THE USE OF TOW STRAPS ARE NECESSARY TO TOW A DISABLED VEHICLE FROM A REPAIR FACILITY PARKING LOT INTO THE SHOP BAY. THE TOW STRAPS SHOULD BE CONNECTED TO THE TOW HOOKS PROVIDED BY THE VEHICLE MANUFACTURER AT THE FRONT OF THE BUMPER. IF THE USE OF TOW HOOKS IS NOT AN OPTION, THEN TOW STRAPS MAY BE WRAPPED AROUND THE FRONT STEERTEK NXT AXLE, (SEE FIGURE 6-4) IN A MANNER THAT IS ACCEPTABLE FOR TOWING THE VEHICLE FROM A REPAIR FACILITY PARKING LOT INTO THE SHOP BAY. DO NOT USE A TOW CHAIN AROUND THE FRONT STEERTEK NXT AXLE TO TOW THE VEHICLE, DOING SO WILL DAMAGE THE AXLE AND VOID ANY APPLICABLE WARRANTY, SEE FIGURE 6-4.

- NYLON STRAPS OR CHAINS ARE NOT RECOMMENDED FOR ON-HIGHWAY OR ON-ROADWAY TOWING.

FIGURE 6-4

OFF-ROADWAY TOWING





SECTION 7 Preventive Maintenance

Following appropriate inspection procedures is important to help ensure the proper maintenance and operation of the SOFTEK suspension system and components function to their highest efficiency. Hendrickson recommends the SOFTEK equipped with STEERTEK NXT axle front suspension systems be inspected at pre-delivery, the first 1,000 miles of service and at the regular preventive maintenance intervals.

NOTE Torque values shown in this publication apply only if Hendrickson supplied fasteners are used. If non-Hendrickson fasteners are used, follow the torque specifications listed in the vehicle manufacturer’s service manual.

HENDRICKSON RECOMMENDED INSPECTION INTERVALS	PRE-DELIVERY INSPECTION	FIRST IN-SERVICE INSPECTION	PREVENTIVE MAINTENANCE
Visual inspection for proper assembly and function. Check for all of the following and replace components as necessary: <ul style="list-style-type: none"> • Signs of unusual movement, loose or missing components • Signs of abrasive or adverse contact with other components • Damaged, or cracked parts • Improper suspension function or alignment 	Within the First 100 Miles (500 Km)	Within the First 1,000 Miles (1,600 Km) or 100 Hours	On-Highway 25,000 Miles (40,000 Km) Every 3 Months or Whichever comes First
Visually inspect the overall condition, torque and for any signs of damage to: <ul style="list-style-type: none"> • Axle assembly • Leaf spring assembly • Rear shackle brackets and shackle plates • Clamp group 			On-Highway 100,000 Miles (161,000 Km) Every 12 Months or Whichever comes First
Inspect all fasteners for proper torque using a calibrated torque wrench.			

See vehicle manufacturer’s applicable publications for other preventive maintenance requirements.

COMPONENT INSPECTION

- **Clamp group** — Check torque on clamp group mounting hardware. Refer to Torque Specifications Section of this publication.
- **Fasteners** — Look for any loose or damaged fasteners on the entire suspension. Make sure all fasteners are tightened to the specified torque. Refer to the Tightening Torque Specifications Section in this publication if fasteners are supplied by Hendrickson, non-Hendrickson fasteners, refer to the vehicle manufacturer. Use a calibrated torque wrench to check torque in a tightening direction. As soon as the fastener starts to move, record the torque. Correct the torque if necessary. Replace any worn or damaged fasteners.
- **Front hangers and shackle brackets** — Check for proper fastener torque values using a calibrated torque wrench. Check for cracks or loose mounting hardware. Replace if necessary, see the Component Replacement Section of this publication for replacement procedure.



- **Operation** — All steering components must move freely through the full range of motion from axle stop to axle stop.
- **Shock absorber** — Look for any signs of dents or leakage, misting is not considered a leak. See Shock Absorber Inspection in this section.
- **Steel leaf spring** — Look for cracks. Replace if cracked or broken. Replace if necessary, see the Component Replacement Section of this publication for replacement procedure.
- **Steering pivot points** — Check for looseness at all pivot points. Inspect and lubricate all pivot points. Refer to the Trouble Shooting Guide Section in the Appendix of this publication.
- **STEERTEK NXT Axle** — The axle should be free of any nicks or gouges. Inspect for any cracks or dents on axle.
- **Tire wear** — Inspect tires for wear patterns that may indicate suspension damage or misalignment. See Tire Inspection in this section.
- **Top pad and bump stop** — Check for cracks and/or missing rubber bump stops. Replace if necessary, see the Component Replacement Section of this publication for replacement procedure.
- **Wear and damage** — Inspect all parts of suspension for wear and damage. Look for bent or cracked parts. Replace all worn or damaged parts.

Also see vehicle manufacturer’s applicable publications for other preventive maintenance requirements.

LUBRICATION INTERVALS

For vehicles equipped with the STEERTEK NXT axle, regular lubrication intervals should be followed to help prevent premature wear to the kingpin bushings and tie rod ends, see Lubrication Specifications in Table 7-1.

NOTE The recommended service lubrication interval is a guideline, the vehicle may require increased lubrication interval depending on severity of operation.

TABLE 7-1

STEERTEK NXT Greasing and Lubrication Specifications					
	Application	Component	Greasing Interval	Grease	Outside Temperature
GENERAL	Does not include line-haul or medium-duty applications	Kingpin Bushings	Maximum of 25,000 miles (40,225 km) or 90 days, whichever comes first	Multipurpose Grease NLGI Grade 2	Refer to the lubricant manufacturer’s specifications for the temperature service limits applicable to your area
		Tie Rod Ends			
		Drag Link	See Vehicle Manufacturer		
Application Specific Recommendations					
ON-HIGHWAY	Line-haul Only, High Mileage Accumulation	Kingpin Bushings	Maximum of 100,000 miles (161,000 km) or 1 year, whichever comes first	Multipurpose Grease NLGI Grade 2	Refer to the lubricant manufacturer’s specifications for the temperature service limits applicable to your area
	95% Highway Surface	Tie Rod Ends			
	No off-roadway operation Greater than 50,000 miles per year (80,500 kilometers per year)	Drag Link	See Vehicle Manufacturer		

NOTE: Lubrication greases acceptable for use on the STEERTEK NXT axle will carry a designation of NLGI #2 EP and rated GC-LB or equivalent.



KINGPIN LUBRICATION

STEERTEK NXT upper kingpin grease zerks are located on the inboard side of the steering knuckle and upper kingpin connection, see Figure 7-1.

1. Place vehicle on the ground.
2. Prior to greasing the kingpins on the vehicle, the suspension must be in a loaded condition.
3. Clean off all the grease zerks and grease gun tip with a clean shop towel prior to lubrication.
4. Lubricate the kingpins through the grease zerks on the top and bottom of the steering knuckle, see Lubrication Specification chart above.
5. Force the required lubricant into the upper and lower kingpin grease zerks, until new lubricant flows out from the upper kingpin connection and steering knuckle and the thrust bearing purge location, see Figures 7-2 and 7-3.

FIGURE 7-1



FIGURE 7-2



FIGURE 7-3

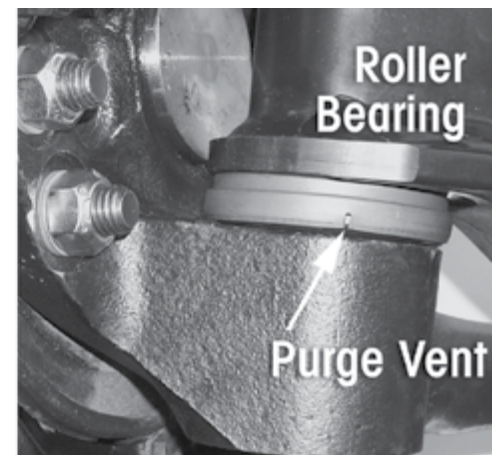

NOTE

Greasing at the lower fitting should purge grease from the thrust bearing shell. The left side of the axle has a composite style thrust bearing and the right side of the axle has a steel roller thrust bearing, see Figures 7-4 and 7-5. Both purge in the same area.

FIGURE 7-4



FIGURE 7-5



Top View of Thrust Bearings
COMPOSITE THRUST BEARING **ROLLER THRUST BEARING**
 Left Side Right Side

TIE ROD END

LUBRICATION PROCEDURE

1. Turn the vehicle wheels straight ahead.
2. Wipe the grease zerk and grease gun tip with clean shop towels.
3. Wipe the seal/boot clean with shop towels.
4. Attach a grease gun to the grease zerk. Either a hand or pneumatic grease gun is acceptable. If air operated grease gun is used, system air pressure should not exceed 150 psi (1035 kPa).



EXCEEDING THE MAXIMUM AIR PRESSURE TO THE GREASE ZERK CAN CAUSE DAMAGE TO THE DUST BOOT AND COMPONENT FAILURE.

5. Dirt, water, and discolored old grease should flow from the relief vents or purge holes near the boot crimp or bellows area, see Figure 7-6. Continue to purge grease until fresh grease flows from the purge area.
6. If the tie rod end is designed for lube service and it will not accept grease proceed as follows:
 - a. Remove the grease zerk
 - b. Inspect the threaded grease zerk hole in the tie rod end and remove any obstructions
 - c. Install a new grease zerk
 - d. Continue the lubrication procedure
 - e. If the tie rod end will not accept grease following this procedure it will be necessary to replace the tie rod end (see Tie Rod End replacement in the Component Replacement Section of this publication).
7. Apply grease until all the old grease is purged from the boot and fresh grease is coming out.

FIGURE 7-6

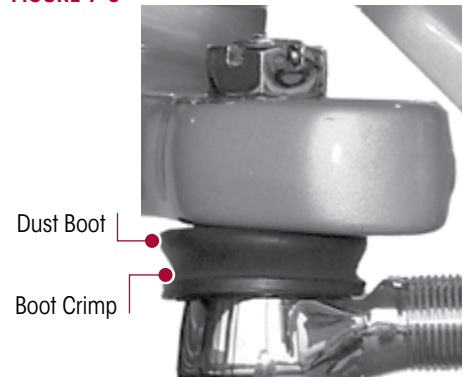

INSPECTION

Before beginning this inspection procedure, the entire system must be unloaded (i.e., the front end of the vehicle must be raised and supported with safety stands).



DO NOT GREASE THE TIE ROD ASSEMBLY BEFORE PERFORMING THE INSPECTION. DOING SO CAN INHIBIT EFFORTS TO DETERMINE ACTUAL WEAR.



REPLACE THE ENTIRE TIE ROD END IF THE BOOT IS TORN OR MISSING, FAILURE TO DO SO CAN CAUSE PREMATURE WEAR OF THE TIE ROD END.

1. Block rear wheels of vehicle. Using the bottom of the axle beam or the frame rails, raise the front end off the ground and support with stands.
2. With the engine off, turn the wheels from full left to full right and then return to the straight-ahead position.
3. Check that the boots are in place and completely installed over the tie rod ends.
4. Check for cracking or tears in the boots. Also check the boot seals for damage. Replace the entire tie rod end if the boot is damaged.



THE COTTER PIN MUST BE INSTALLED CORRECTLY THROUGH THE TIE ROD END WITH THE CASTLE NUT TIGHTENED TO THE PROPER TORQUE SPECIFICATION IN ORDER TO SECURELY ATTACH THE TIE ROD. LOSS OF THE COTTER PIN CAN CAUSE THE TIE ROD END NUT TO BECOME LOOSE AND POSSIBLY RESULT IN TOTAL LOSS OF VEHICLE CONTROL.

5. Check that the tie rod end nut is installed and secured with a cotter pin. If the cotter pin is missing, check the nut torque specification and then install a new cotter pin. Always tighten the castle nut to specified torque when setting the cotter pin. **DO NOT** back off the nut to insert cotter pin.

WARNING

IT IS CRITICAL TO CHECK THE $\frac{5}{8}$ " TIE ROD CLAMP BOLT HEAD LOCATION TO VERIFY THE CLAMP FASTENERS HAVE SUFFICIENT CLEARANCE AWAY FROM THE LOWER SHOCK MOUNT AT FULL WHEEL CUT. THE FASTENERS MUST NOT CONTACT THE LOWER SHOCK MOUNT. FAILURE TO DO SO CAN CAUSE ONE OR MORE COMPONENTS TO FAIL CAUSING LOSS OF VEHICLE CONTROL AND POSSIBLE PERSONAL INJURY OR PROPERTY DAMAGE.

- Verify the $\frac{5}{8}$ " tie rod clamp bolt head does not contact the lower shock mount at full wheel cut, see Figure 7-7.

WARNING

THE THREADED PORTION OF THE TIE ROD END MUST EXTEND PAST THE SLOTS INTO THE TIE ROD CROSS TUBE, SEE FIGURE 7-7. FAILURE TO DO SO CAN CAUSE COMPONENT DAMAGE, LOSS OF VEHICLE CONTROL AND POSSIBLE PERSONAL INJURY OR PROPERTY DAMAGE.

- Check that the tie rod end is threaded correctly into the cross tube and is engaged deeper than the end of the cross tube slot. The tie rod end must be visible the entire length of the cross tube slot, see Figure 7-7.

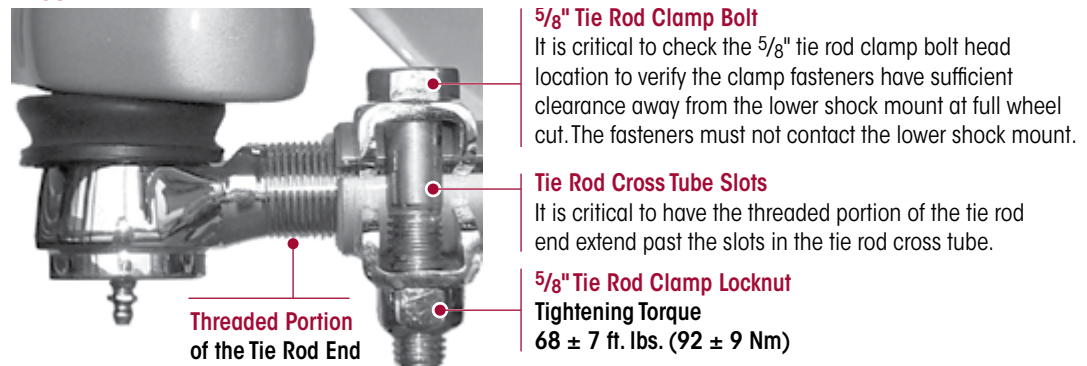
FIGURE 7-7

- Check that grease zerks are installed. Replace a damaged grease zerk with a new one.

CAUTION

DO NOT USE THE FOLLOWING ITEMS OR METHODS TO CHECK FOR MOVEMENT OF THE TIE ROD ASSEMBLY, WHICH CAN CAUSE DAMAGE TO COMPONENTS:

- A CROW BAR, PICKLE FORK OR 2 x 4
 - ANYTHING OTHER THAN HANDS USED TO GRASP AND ROTATE THE CROSS TUBE ASSEMBLY (CAN RESULT IN DAMAGE TO THE CROSS TUBE)
 - EXCESSIVE PRESSURE OR FORCE APPLIED TO THE TIE ROD ENDS OR THE JOINTS OF THE ASSEMBLY
- By hand or using a pipe wrench, with jaw protectors to avoid gouging the cross tube, rotate the cross tube toward the front of the vehicle and then toward the rear. After rotating, center the cross tube. If the cross tube will not rotate in either direction, replace both tie rod ends, see Figure 7-8.
 - Position yourself directly below the tie rod end. Using both hands, grab the assembly end as close to the tie rod end as possible (no more than 6" or 152.4 mm). Apply hand pressure with reasonable human effort vertically up and down in a push-pull motion several times, using approximately 75 ± 25 foot pounds of force. Check for any movement or looseness at both tie rod end locations, see Figure 7-9.

FIGURE 7-8

FIGURE 7-9

11. If there is any movement in the tie rod assembly, install a magnetic based dial indicator on the Ackermann arm, see Figure 7-10.
12. Set the dial indicator to zero.
13. Apply hand pressure with reasonable human effort vertically up and down in a push-pull motion several times (using approx. 75 ± 25 lb. of force). Observe the reading on the dial indicator.
14. If the reading is more than 0.060", replace both tie rod ends at the next service interval.
15. If a tie rod end exhibits ≥ 0.125 " of movement by hand, the vehicle should be removed immediately from use and the tie rod end be replaced.

FIGURE 7-10

NOTE

According to the Commercial Vehicle Safety Alliance (CVSA), the "out of service" criteria for front steer axle tie rod assemblies on any commercial vehicle is: Any motion other than rotational between any linkage member and its attachment point of more than $\frac{1}{8}$ " (3 mm) measured with hand pressure only. (393.209(d)). (published in the North American Standard Out-of-Service Criteria Handbook, April 1, 2006.)

CLAMP GROUP RE-TORQUE INTERVAL
WARNING

LOOSE OR OVER TORQUED FASTENERS CAN CAUSE COMPONENT DAMAGE, LOSS OF VEHICLE CONTROL, PROPERTY DAMAGE, OR SEVERE PERSONAL INJURY. MAINTAIN CORRECT TORQUE VALUES AT ALL TIMES. CHECK TORQUE VALUES ON A REGULAR BASIS AS SPECIFIED.

1. Clamp group locknuts must be torqued to specification at preparation for delivery.
2. Clamp group locknuts must be re-torqued at 1,000 miles thereafter, follow the 6 month / 50,000 mile inspection and annual re-torque interval.

WARNING

ENSURE CLAMP GROUP IS ALIGNED PROPERLY PRIOR TO TIGHTENING HARDWARE. FAILURE TO DO SO CAN CAUSE LOSS OF VEHICLE CONTROL, PROPERTY DAMAGE OR PERSONAL INJURY.

3. Ensure that the clamp group is properly aligned and the U-bolts are seated in the top pad, and the top pad is centered on the axle spring seat, see Figure 7-11.



4. Check for the signs of component or bolt movement.
5. If signs of movement are present, disassemble the clamp group fasteners, check for component wear or damage and replace as necessary, then install new clamp group fasteners and repeat Steps 1 through 4.

FIGURE 7-12

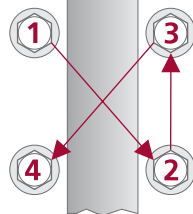

6. Tighten the clamp group locknuts evenly in 50 foot pounds increments to vehicle manufacturer's torque specification in the proper pattern to achieve uniform bolt tension, see Figure 7-12.

FIGURE 7-11

IMPORTANT
Ensure that Axle Clamp Group is properly aligned

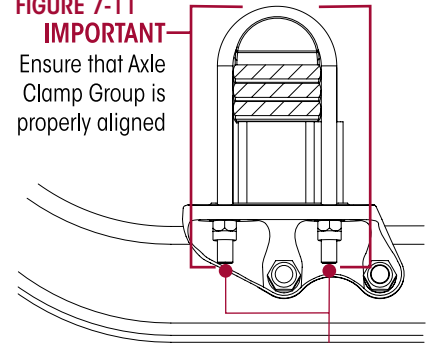

¾" Clamp Group Locknuts
Tightening Torque
295 ± 10 ft. lbs. (400 ± 14 Nm)

SURFACE PAINT WEAR INSPECTION

Front Hanger • Rear Shackle Bracket — Hendrickson SOFTEK suspension systems equipped on LionE vehicles utilize rubber bushings in the leaf springs. These rubber bushings allow the leaf spring to deflect and may contact the front hanger and shackle plates when the truck encounters high lateral acceleration (e.g. a highway clover leaf). The rubber bushing will center the leaf spring between the legs of the hanger/shackle plates once the vehicle is driven straight.

This function of the rubber bushing may allow the leaf spring to contact the front hanger/rear shackle plate and possibly remove surface paint from the contact area. Surface paint wear does not cause damage that will affect the function or durability of the front hanger/rear shackle plate or their mating components provided a minimum wall thickness is maintained.

An indication that the front hanger/ rear shackle plates are worn and require replacement is when the components no longer meet the following minimum requirements:

- Front hanger inboard leg minimum thickness of 9.15 mm and the outboard leg thickness minimum thickness 11.00 mm, see Figure 7-13.
- Rear shackle plate minimum thickness of 5.8 mm, see Figure 7-13.

FIGURE 7-13
Front Hanger

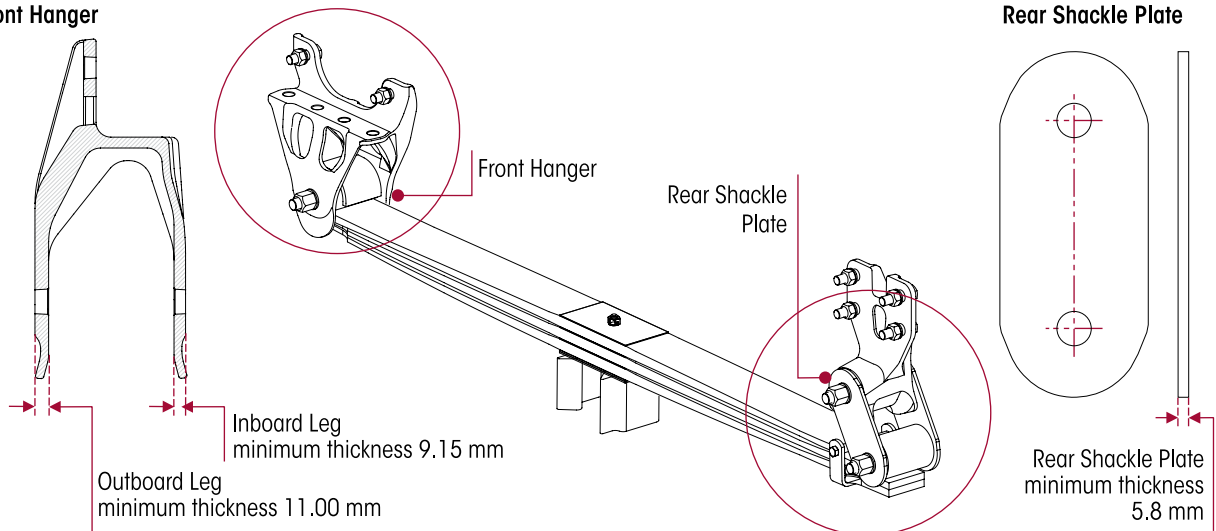

KINGPIN BUSHING

INSPECTING STEERING KNUCKLE LATERAL MOVEMENT

1. Chock the wheels to help prevent the vehicle from moving. Set the parking brake.
2. Use a jack to raise the vehicle until the wheels are off the ground. Support the vehicle with safety stands.
3. **CHECKING THE UPPER KINGPIN BUSHING.** Install the base of a dial indicator onto the axle beam and place the tip against the steering knuckle, see Figure 7-14.
4. Set the dial indicator to "0" zero.
5. Move the top of the tire in and out by applying reasonable constant pressure and then release, see Figure 7-16.
6. Check the reading on the dial indicator. If the dial indicator moves more than 0.015", the upper bushing is worn or damaged. Replace both bushings. Refer to the Kingpin Bushing replacement procedure in the Component Replacement Section of this publication.
7. **CHECKING THE LOWER KINGPIN BUSHING.** Install a dial indicator so that the base is on the axle and the indicator tip is against the inside of the bottom of the knuckle, see Figure 7-15.

FIGURE 7-14

CHECK UPPER KINGPIN BUSHING



FIGURE 7-15

CHECK LOWER KINGPIN BUSHING



FIGURE 7-16

MOVE BOTTOM OF TIRE IN AND OUT



8. Set the dial indicator to "0" zero.
9. Move the bottom of the tire in and out. If the dial indicator moves more than 0.015", the lower bushing is worn or damaged. Replace both kingpin bushings. Refer to the Component Replacement Section of this publication.

NOTE

If one (1) bushing is worn or damaged, it is mandatory to replace both the top and bottom bushings on that knuckle assembly.

STEERING KNUCKLE

CHECKING VERTICAL END PLAY (UP AND DOWN MOVEMENT)

The operating spec for vertical end play on the steering knuckle is 0.008" to 0.030".

1. Chock the rear tires to help prevent the vehicle from moving.
2. Set the parking brakes.
3. Use a jack to raise the vehicle until both tires are 1" off the ground.
4. Place a dial indicator on each side of the axle as follows:
 - a. Index the wheels slightly (left or right).

- b. Place the magnetic dial indicator base on the axle, see Figure 7-17.
- c. Place the tip of the dial indicator on the top of the upper steering knuckle (not on the grease cap).
5. Set the dial indicator to "0" (zero).
6. Lower the jack.
7. If vertical end play is greater than 0.030", or below 0.008" an adjustment of the upper knuckle is necessary.
8.
 - If the vertical end play is **greater than 0.030"**, loosen the socket head cap screws and **push down** on the knuckle assembly until the proper vertical end play is achieved.
 - If the vertical end play is **less than 0.008"**, loosen the socket head cap screws and **pull up** on the knuckle assembly until the proper vertical end play is achieved.
9. Retighten the socket head cap screws to $\boxed{188} \pm 12$ foot pounds torque.



SHOCK ABSORBER

NOTE

It is not necessary to replace shock absorbers in pairs if only one (1) shock absorber requires replacement.

Hendrickson uses a long service life, premium shock absorber on all SOFTEK suspensions. If shock absorber replacement is necessary, Hendrickson recommends that the shock absorbers be replaced with identical Hendrickson Genuine parts for servicing. Failure to do so will affect the suspension performance, durability, and will void any applicable warranty. See vehicle manufacturer's applicable publications for other shock absorber inspection requirements.

Inspection of the shock absorber can be performed by doing a heat test, and a visual inspection. Replace as necessary, refer to the Component Replacement Section of this publication.

HEAT TEST

1. Drive the vehicle at moderate speeds on rough road for minimum of fifteen minutes.



WARNING

DO NOT GRAB THE SHOCK ABSORBER AS IT COULD POSSIBLY BE HOT AND CAUSE PERSONAL INJURY.

2. Use an infrared thermometer to check the temperature of the shock absorber. This can also be performed by carefully touching the shock absorber body below the dust cover. Touch the frame to get an ambient reference, see Figure 7-18. A warm shock absorber is acceptable, a cold shock absorber should be replaced.
3. To inspect for an internal failure, remove and shake the suspected shock absorber. Listen for the sound of metal parts rattling inside. Rattling of metal parts can indicate that the shock absorber has an internal failure and the shock absorber should be replaced.

FIGURE 7-18



VISUAL INSPECTION

Look for these potential problems when doing a visual inspection. Inspect the shock absorbers fully extended. Replace as necessary.

FIGURE 7-19

SHOCK ABSORBER VISUAL INSPECTION - UNACCEPTABLE CONDITIONS

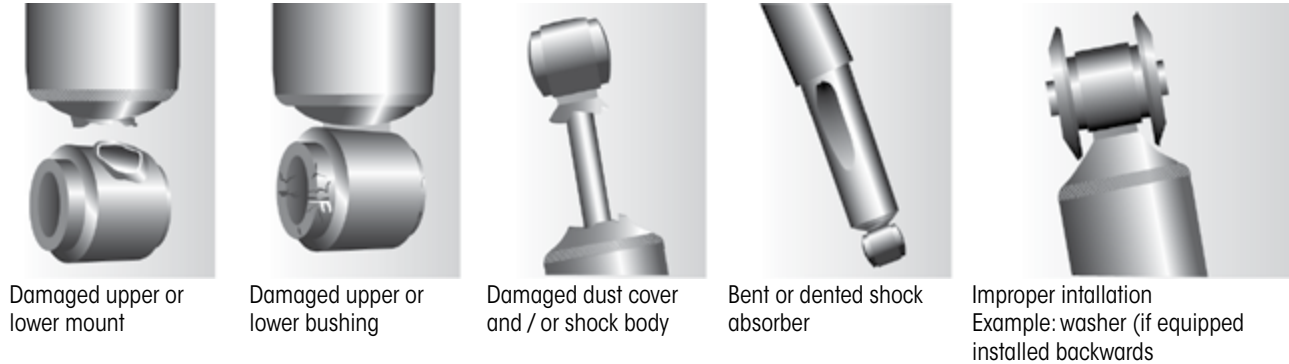

LEAKING VS. MISTING SHOCK ABSORBER VISUAL INSPECTION

The inspection must not be conducted after driving in wet weather or a vehicle wash. The shock absorber needs to be free from water. Many shock absorbers are often misdiagnosed as failures. Misting is the process whereby very small amounts of shock absorber fluid evaporate at a high operating temperature through the upper seal of the shock absorber. When the "mist" reaches the cooler outside air, it condenses and forms a film on the outside of the shock absorber body. Misting is perfectly normal and necessary function of the shock absorber. The fluid which evaporates through the seal area helps to lubricate and prolong the life of the seal.

FIGURE 7-20

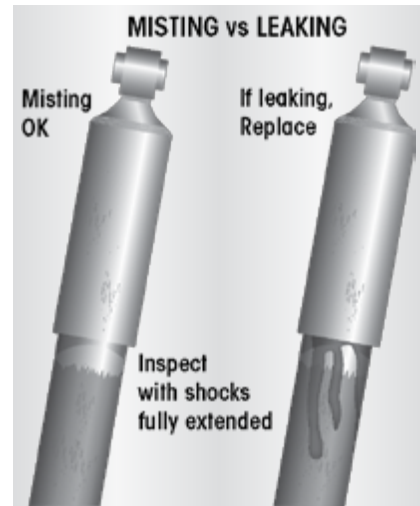

NOTE

SOFTEK Suspension systems are equipped with a premium seal on the shock absorber, however this seal will allow for misting to appear on the shock absorber body (misting is not a leak and is considered acceptable).

Inspect the shock absorber fully extended. **A shock absorber that is truly leaking** will show signs of fluid **leaking in streams from the upper seal**. These streams can easily be seen, underneath the main body (dust cover) of the shock absorber. Replace as necessary.

TIRE INSPECTION

The leading causes of tire wear are the following, in order of importance:

1. Tire Pressure
2. Toe Setting
3. Thrust Angle
4. Camber

The following tire Inspection guidelines are based upon Technology & Maintenance Council (TMC) recommended practices. Any issues regarding irregular tire wear where Hendrickson is asked for assistance, will require tire and alignment maintenance records, reference TMC's literature numbers RP 219A, RP 230, or RP 642.

Tire wear is normally the best indicator of vehicle alignment condition. If tires are wearing too rapidly or irregularly, alignment corrections may be needed. The tire wear patterns described below can help isolate specific alignment problems.

The most common conditions of concern are:

- Overall Fast Wear (Miles per 32nd)
- Feather Wear
- Cupping
- Diagonal Wear
- Rapid Shoulder Wear (One Shoulder Only)
- One-Sided Wear

FIGURE 7-21

OVERALL FAST WEAR (Miles per 32nd)

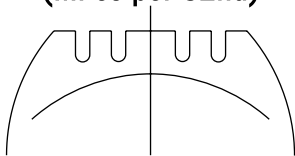

Overall Fast Wear — Fast wear can be described as exhibiting a good, but accelerated wear pattern. It is typically caused by operating conditions, such as mountainous terrain, frequency and severity of turning, abrasive road surfaces in combination with vehicle configurations and their attributes—such as power steering, heavy axle loads, high wheel cuts, setback axles, short wheel base tractors, long wheel base straight trucks. To correct this problem, consult with vehicle and tire manufacturers when specifying equipment or replacing tires. For more information, see TMC RP 219A publication, page 11. For information on how to accurately measure and record tire rates, see TMC RP 230 publication.

FIGURE 7-22

FEATHER WEAR

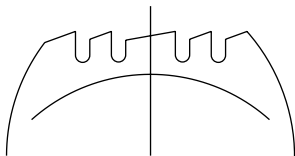

Feather wear — Tread ribs or blocks worn so that one side is higher than the other resulting in step-offs across the tread face. Generally, ribs or blocks exhibit this wear. To spot this problem, do the following:

With one hand flat on the tread of the tire and a firm down pressure, slide your hand across the tread of the tire. In one direction, the tire will feel smooth and in the opposite direction there will be a sharp edge to the tread. Typical causes of feather wear include: excessive side force scrubbing, resulting from conditions of misalignment such as excessive toe, drive axle misalignment, worn, missing or damaged suspension components, bent tie rods or other chassis misalignment.

To correct this problem, tires can be rotated to another axle for maximum utilization of remaining tread. Additionally, diagnose the vehicle itself and correct misalignment condition as required. If steer tire feathers are in opposite directions, an improper toe condition is most likely the cause. For more information, see TMC RP 219A publication, page 5.

If feather wear on both steer tires is in the same direction, drive axle or other chassis misalignment is indicated. If one steer tire shows feather wear and the other steer tire has normal wear, a combination of toe and drive axle or chassis misalignment is indicated.

FIGURE 7-23

RAPID SHOULDER WEAR (One Shoulder Only)

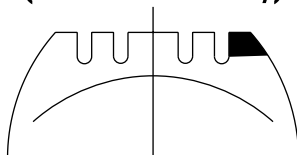

Rapid Shoulder Wear (One Shoulder Only) — Is defined as a tire worn on the edge of one shoulder, sometimes extending to inner ribs. It can progress to diagonal wipeout. For more information, see TMC RP 219A publication, page 22.

This wear condition is usually caused by excessive toe or excessive camber. These conditions can be created by a misaligned or bent axle and can also be caused by loose or worn wheel bearings.

To correct this type of rapid shoulder wear:

- Tires – Change direction of rotation of tire. If shoulder wear is severe, remove and retread.
- Vehicle – Diagnose misalignment and/or mechanical condition and correct.

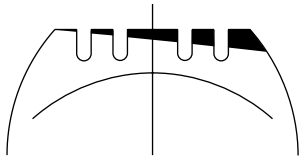
FIGURE 7-24
ONE-SIDED WEAR

One-sided wear — Is excessive wear on one side of tire extending from the shoulder towards the center of the tread. For more information, see TMC RP 219A, page 26.

One-sided wear is usually caused by improper alignment, worn kingpins, loose wheel bearings, excessive camber, excessive axle loads, non-parallel axles, or non-uniform tire and wheel assembly caused by improper bead seating or bent wheel.

To correct one-sided wear:

- Tires – Depending on severity, rotate tires to another axle position or, if worn to minimum tread depths, submit for possible retreading.
- Vehicle – Diagnose mechanical problem and correct.

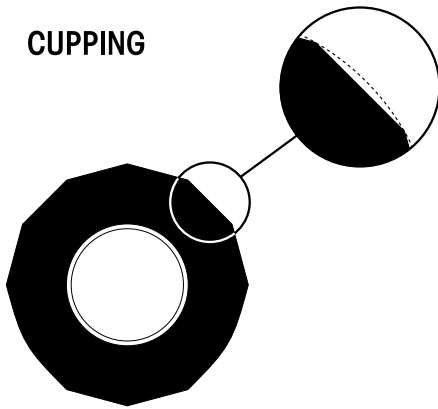
FIGURE 7-25
CUPPING

Cupping — Localized, dished out areas of fast wear creating a scalloped appearance around the tire. Cupping, which appears around the tire on the shoulder ribs, may also progress to adjoining ribs, see TMC RP 219A publication, page 7.

Cupping is usually a result of moderate-to-severe imbalance, improper rim/wheel mounting, excessive wheel end play or other assembly non-uniformity. It can also be due to lack of shock absorber control on some suspension types.

To solve cupping problems:

- Tires – Correct mismatch or balance problem. If ride complaints arise, steer tires may be rotated to drive or trailer axle.
- Vehicle – Diagnose component imbalance condition, i.e., wheel, rim, hub, brake, drum. Correct as necessary.

Diagonal Wear — Can be described as localized flat spots worn diagonally across the tread at approximately 25-35° angles, often repeating around the tread circumference. For more information, see TMC RP 219A publication, page 20.

Diagonal wear is usually caused by bad wheel bearings, toe out, mismatching of tire and wheel assembly to axle, and mismatched duals for size and/or inflation pressures. It may start as brake skid. Diagonal wear is aggravated by high speed empty or light load hauls.

To correct diagonal wear, reverse direction of rotation of the tire. If wear is excessive, true tire. If the source of trouble is the vehicle, diagnose cause and correct as needed.

BRAKES AND WHEEL BEARING END PLAY

Refer to component manufacturer for wheel bearing end play inspection and wheel bearing adjustment procedures, see Parts List Section of this publication for contact information.

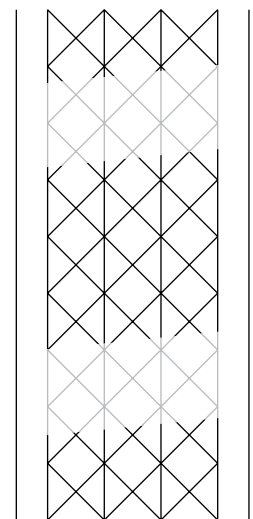
FIGURE 7-26
DIAGONAL WEAR

SECTION 8 Alignment & Adjustments

ALIGNMENT DEFINITIONS

FIGURE 8-1

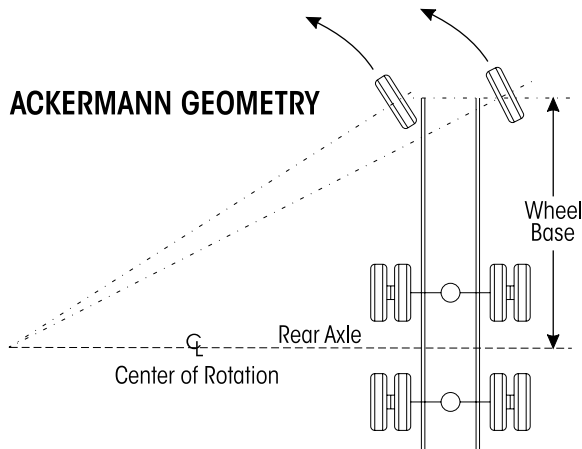

ACKERMANN STEERING GEOMETRY — The geometry of the four bar linkage consisting of the front axle beam pivot points, tie rod arms, and cross tube and attempts to provide free rolling of front tires in a turn. Ackermann geometry is dependent upon the steering axle track-width and wheelbase of the vehicle. Improper geometry results in wheel scrub in turns which generally appears as toe wear on the tire, usually more wear on one side of the vehicle than the other due to the operational route of the vehicle.

Bump Steer (Feedback) — The feedback felt through the steering linkage to the steering wheel when a steer axle tire hits a bump in the road. This occurs because the axle-end of the drag link and the axle attachment point of the spring do not travel in parallel circular arcs as the suspension moves up and down. This condition can also be caused by trapped air in the power steering system.

FIGURE 8-2

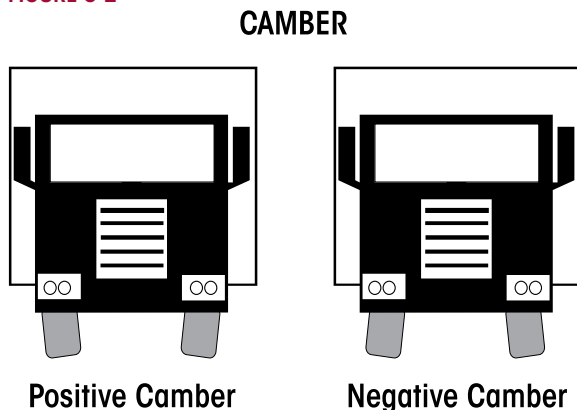

Camber — The angle formed by the inward or outward tilt of the wheel reference to a vertical line. Camber is positive when the wheel is tilted outward at the top and is negative when the wheel is tilted inward at the top.

Excessive positive camber may cause smooth wear on the outer half of the tire tread. Excessive negative camber may cause wear on the inner half of the tread. Static-unloaded camber angles are built into the axle to put the loaded tire perpendicular to the road.

FIGURE 8-3

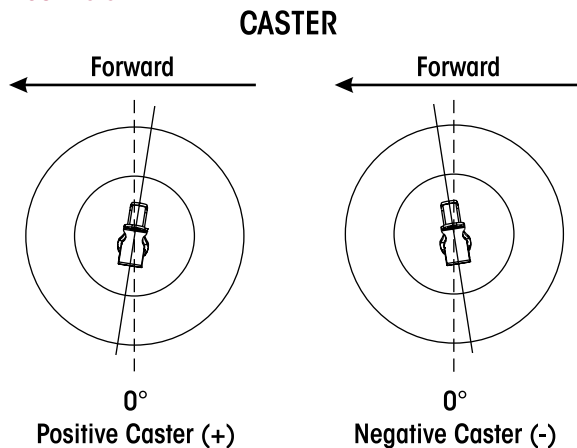

Caster — The forward or rearward tilt of the steering axle kingpin in reference to a vertical line. The angle is measured in degrees. Caster is positive when the top of the steering axis is tilted rearward and is negative when the tilt is forward. Proper caster is important for directional stability and returnability. Too much positive caster can cause shimmy, excessive steering effort and is normally a vehicle performance and handling consideration. Uneven positive caster may create a steering pull toward the side with the lower caster. This attribute may be used to compensate for crowned roads.

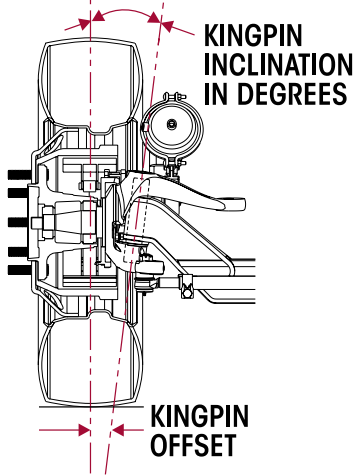
FIGURE 8-4

Kingpin Inclination — The inward tilt of the kingpin from the vertical. This front suspension parameter has a pronounced effect on steering effort and returnability. As the front wheels are turned around an inclined kingpin, the front of the truck is lifted. This lifting of the vehicle is experienced as steering effort when the turn is executed and exhibits itself as recovery force when the steering wheel is released.

Kingpin Offset — The distance between the center of the tire patch and intersection of the kingpin axis with the ground. This parameter of front end geometry is important in vehicles without power steering and has a major effect on static steering. If there is no kingpin offset, the tires must scrub around the center of the pin patch when turned in a static condition, resulting in higher static steering efforts.

Steering Arm — The component that connects the drag link to the axle knuckle assembly.

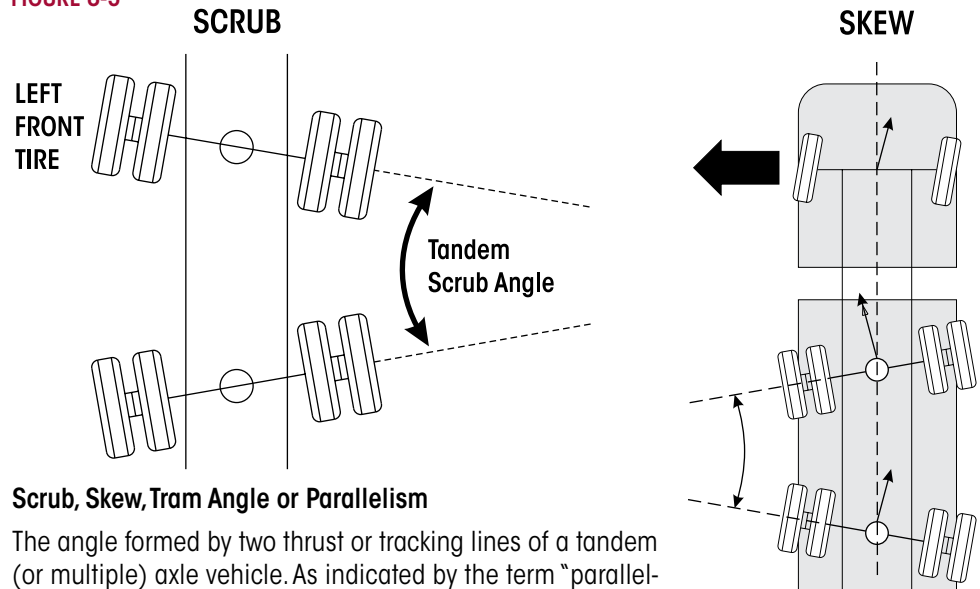
FIGURE 8-5

Scrub, Skew, Tram Angle or Parallelism

The angle formed by two thrust or tracking lines of a tandem (or multiple) axle vehicle. As indicated by the term "parallelism", the ideal condition is when the two thrust lines form a 0° angle, or are parallel to each other. Positive skew or tram is when the distance between the right axle ends is less than the distance between the left.

Any scrub angle other than 0° will cause the tandem axles to work against each other. The steer axle must be turned to offset the "push" of the tandem axles to keep the vehicle moving straight ahead. This causes every tire on the vehicle to "scrub". Tire wear from tandem scrubbing occurs at the leading edge of the steer tires in a pattern called "inside / outside" wear, that is, the inside edge of the left steer tire and the outside edge of the right steer tire will exhibit irregular wear for example. Additional tire wear may occur on all tandem axle tires.

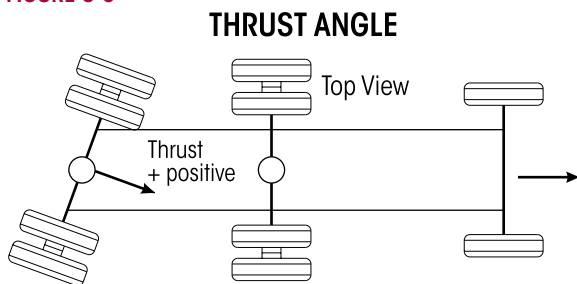
FIGURE 8-6

Thrust Angle, Tracking, or Square — The angle formed by the centerline of the vehicle frame (geometric centerline) and the direction that an axle points. As indicated by the term "square", the ideal value for the angle is 0° or when the axle centerline is at 90° or perpendicular to the geometric centerline. Thrust or tracking to the right is positive, and to the left is negative.

A steering correction is required to offset the effect of the thrust angles and keeps the vehicle traveling in a straight line. It results in a lateral offset between the steer and drive axle tires commonly referred to as "dog tracking."

Tie Rod Arm (Ackermann-Arm, Cross Tube Arm) — The component that transmits steering forces between left and right axle knuckle assemblies through the cross tube assembly.

Toe-in — is when the horizontal line intersects in front of the wheels, or the wheels are closer together in front than in the back. Toe-in is commonly designated as positive, toe-out as negative. Excessive toe-in wears the outside edge of the tires. Steer axle toe is adjustable to reduce wear to the leading edge of the tire and also to avoid road wander. Toe is adjusted in a static, unloaded condition so that the tires will run in a straight line under a dynamic, loaded condition.

FIGURE 8-7

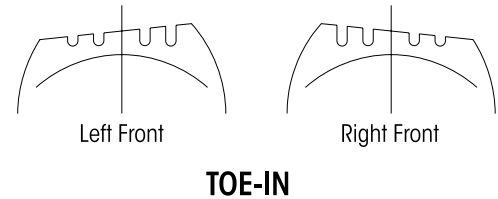

Toe-out — Is when the horizontal lines intersect behind the wheels, or the wheels are closer together in back than in front. Toe-in is commonly designated as positive, toe-out as negative. Excessive toe-out wears the inside edge of the tires. Steer axle toe is adjustable to reduce wear to the leading edge of the tire and also to avoid road wander. Toe is adjusted in a static, unloaded condition so that the tires will run in a straight line under a dynamic, loaded condition.

FIGURE 8-8

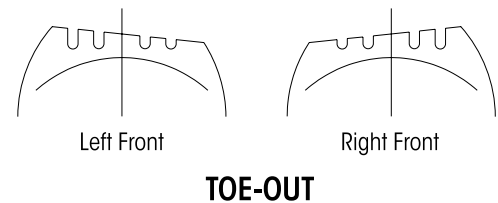

Toe-Out on Turns — (See Ackermann Geometry). Excessive turning angles such as those encountered in pickup and delivery operations may contribute to premature tire wear. Be advised that the greater turning angles, the more that toe and camber change. If you have any doubt regarding the optimum turning angles for your operation, contact the vehicle's manufacturer, axle OEM, tire OEM and alignment equipment manufacturer for advice.

Total Toe — The angle formed by two horizontal lines through the planes of two wheels. Steer axle toe is adjustable to reduce wear to the leading edge of the tire and also to avoid road wander. Toe is adjusted in a static, unloaded condition so that the tires will run in a straight line under a dynamic, loaded condition.

FIGURE 8-9

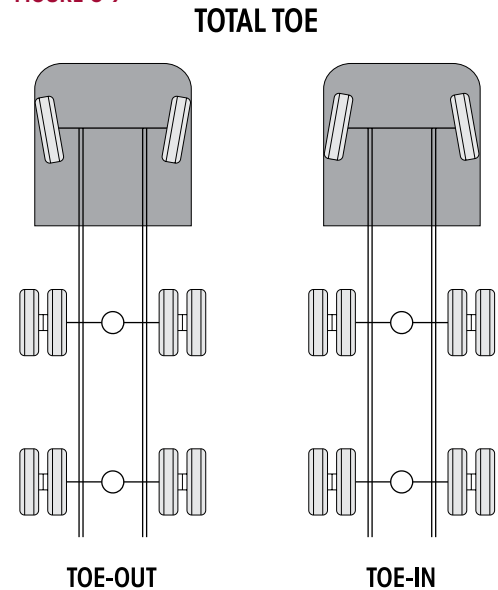



INSPECTION PRIOR TO ALIGNMENT

WHEELS AND TIRES

Examine the following items:

- The tires are inflated to the manufacturer's specified tire pressure.
- The steer axle tires are the same size and type.
- The lug nuts are tightened to manufacturer's specified torque.
- The wheels are balanced and check for tire to rim runout.
- The wheels and tires are free of excessive wear and damage.
- Wheel bearing end play is within OEM specification.

FRONT SUSPENSION

Inspect the following:

- All fasteners are installed and tightened to the specified torque. See  Torque Specification Section of this publication.
- Leaf springs are free of wear or damage.
- Shock absorbers are free of wear and damage.
- Vehicle ride height for both the front and rear are within specification. Follow manufacturer's guidelines (if equipped).
- Front and rear spring mounts for wear or damage.

TIE ROD ENDS

Perform the Tie Rod Inspection procedure; refer to the Preventive Maintenance Section in this publication.

REAR AXLE AND REAR SUSPENSION

Rear axle misalignment can cause front tire wear. If the outer edge of one front tire is worn and the inner edge of the other front tire is worn, check the following:

- Make sure the rear axle (especially a tandem axle) is correctly aligned. Refer to the procedure from the manufacturer of the vehicle or the suspension.
- All fasteners including U-bolts (if applicable) are installed and tightened to the specified torque.
- The leaf springs are not worn or damaged.
- The bushings in the leaf springs are not worn or damaged.
- The torque rods (if used) are correctly adjusted (if adjustable).
- The frame is not bent or twisted.
- Refer to any additional recommendations and specifications from the manufacturer of vehicle on rear axles and suspensions. Reference the TMC (The Technology & Maintenance Council) Guidelines for Total Vehicle Alignment.

FRONT WHEEL ALIGNMENT

Hendrickson recommends technicians review The Technology & Maintenance Council's publication (TMC) "Guidelines for Total Vehicle Alignment" (TMC RP 642).

Check total (front and rear) vehicle wheel alignment when any of the following occurs:

- Every 80,000 to 100,000 miles (128,700 to 160,900 kms), or 12-18 months (normal maintenance), whichever comes first.
- When the vehicle does not steer correctly.
- To correct a tire wear condition.

For **rear** wheel alignment specifications and adjustment refer to the vehicle manufacturer.

The **front** wheel alignment specifications can be found in the Alignment Section of this publication. There are two types of front wheel alignment:

1. **Minor alignment** – a minor front wheel alignment is done **for all** normal maintenance conditions, see below.
2. **Major alignment** – a major alignment is done when uneven or excessive tire wear is evident, or response at the steering wheel is sluggish, or the need for major wheel alignment check and adjustment is required, see below.

MINOR FRONT WHEEL ALIGNMENT

Perform the minor front wheel alignment in the following sequence:

1. Inspect all systems that affect wheel alignment. Refer to Inspection Prior to Alignment in this section.
2. Check the wheel bearing end play.
3. Check and adjust toe if necessary.
4. Check and adjust the vehicle ride height as per vehicle manufacturer.

MAJOR FRONT WHEEL ALIGNMENT

Be certain to follow wheel alignment inspection intervals as specified by the original equipment manufacturer. Before performing a major front wheel alignment it is recommended that alignment equipment calibration be checked to ensure proper vehicle alignment.

Major wheel alignment is accomplished in the following sequence of operation:

1. Inspect all the systems that influence the wheel alignment. Refer to the Inspection Prior to Alignment in this section.
2. Check and adjust the maximum turn angle, refer to the Steering Stop Adjustment Procedure in this section, see Figures 8-10 and 8-11.

FIGURE 8-10



FIGURE 8-11



3. If the vehicle is equipped with power steering, check the pressure relief in the power steering system and reset if necessary. Refer to the vehicle manufacturer regarding the subject: Adjusting the Pressure Relief in the Power Steering System.
4. Check the turning angle. Refer to the original equipment manufacturer specifications.
5. Check the kingpin (or steering axis) inclination. Refer to Kingpin Inclination under Alignment Definitions in this section.

WARNING

AXLE CAMBER IS NOT ADJUSTABLE. DO NOT CHANGE THE AXLE CAMBER ANGLE OR BEND THE AXLE BEAM. BENDING THE AXLE BEAM TO CHANGE THE CAMBER ANGLE CAN DAMAGE THE AXLE AND REDUCE AXLE STRENGTH, AND WILL VOID HENDRICKSON'S WARRANTY. A BENT AXLE BEAM CAN CAUSE LOSS OF VEHICLE CONTROL, POSSIBLY CAUSING PERSONAL INJURY OR PROPERTY DAMAGE, SEE FIGURE 8-12.

WARNING

UNAUTHORIZED TAMPERING OF STEERTEK NXT INTEGRATED AXLE SPRING SEATS CAN CAUSE COMPONENT AND STRUCTURAL DAMAGE AND RESULT IN LOSS OF VEHICLE CONTROL, SEVERE PERSONAL INJURY OR DEATH, PROPERTY DAMAGE, AND WILL VOID ANY APPLICABLE WARRANTY, SEE FIGURE 8-12.

- DO NOT REMOVE, MODIFY OR REPLACE INTEGRATED AXLE SPRING SEAT OR FASTENERS.

NOTE

Contact Hendrickson Tech Services for any questions regarding STEERTEK NXT integrated axle spring seats and / or fasteners.

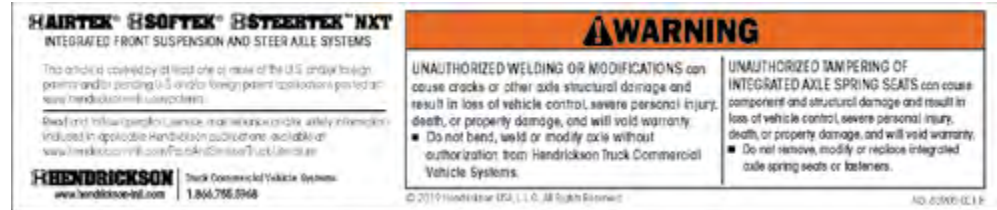
FIGURE 8-12

6. Check the camber angle. **DO NOT** attempt to adjust. Refer to Camber in the Alignment Definitions in this section.
7. It is necessary to verify that all ride heights (front and rear) are within specifications prior to checking caster to get an accurate caster reading.
8. Check and adjust caster angle. Refer to Caster in the Alignment Definitions in this section.

NOTE

The use of two different angle caster shims will not change cross caster. Cross caster is the difference between the caster readings for left and right side of the vehicle.

9. Check and adjust toe-in, refer to Toe Setting in this Section.

STEERING STOP

ADJUSTMENT PROCEDURE

When the axle or lower steering knuckle is replaced, the steering stop adjustment must be checked.

1. Drive the vehicle on turntables and chock the rear wheels.
2. Measure the wheel cut. The wheel cut is determined by steering the tires. Wheel cut is measured at the inside wheel only, therefore the tires must be turned to the full lock position for each right hand and left hand direction. Refer to the vehicle manufacturer for exact specifications.
3. Increase the wheel cut by loosening the jam nuts and screw the axle stops in clockwise.

FIGURE 8-13

4. Tighten the jam nuts.

NOTE

It is very important that the sides of the square head axle stops are set parallel to the axle beam to ensure a good contact point on the axle, see Figure 8-13.

5. Decrease the wheel cut by loosening the jam nuts and screw the axle stops out counter-clock-wise.
6. Tighten the jam nuts to $\boxed{50} \pm 10$ foot pounds (68 ± 14 Nm) torque.

WARNING

7. Measure the wheel cut and check for any interference with related steering components.

ALWAYS CHECK/RESET THE STEERING GEAR BOX POPPET WHEN THE WHEEL CUT IS DECREASED. FOLLOW MANUFACTURER'S GUIDELINES FOR THE GEAR BOX POPPET RESETTING PROCEDURE. FAILURE TO DO SO CAN RESULT IN PREMATURE FAILURE OF THE AXLE OR STEERING KNUCKLE. THIS CONDITION CAN CAUSE LOSS OF VEHICLE CONTROL, POSSIBLE PERSONAL INJURY OR PROPERTY DAMAGE AND VOID ANY APPLICABLE WARRANTY.

TOE SETTING

1. Place the vehicle on a level floor with the wheels in a straight ahead position.
2. Raise the vehicle and support the front axle with jack stands.
3. Use paint and mark the center area of tread on both steer axle tires around the complete outer diameter of the tires.
4. Scribe a line through both steer axle tires in the painted area around the complete outer diameter of the tires.
5. Raise the vehicle and remove the jack stands.
6. Set the vehicle on the ground.

NOTE

DO NOT measure toe-in with the front axle off the ground. The weight of the vehicle must be on the front axle when toe-in is measured.

7. Use a trammel bar and measure the distance between the scribe marks at the rear of the steer axle tires. Record the measurement.
8. Install the trammel bar and measure the distance between the scribe marks at the front of the steer axle tires. Record the measurement, see Figure 8-14.

NOTE

When setting up the trammel bar the pointers should be level with the spindles at the front and rear of the steer axle tires.

FIGURE 8-14

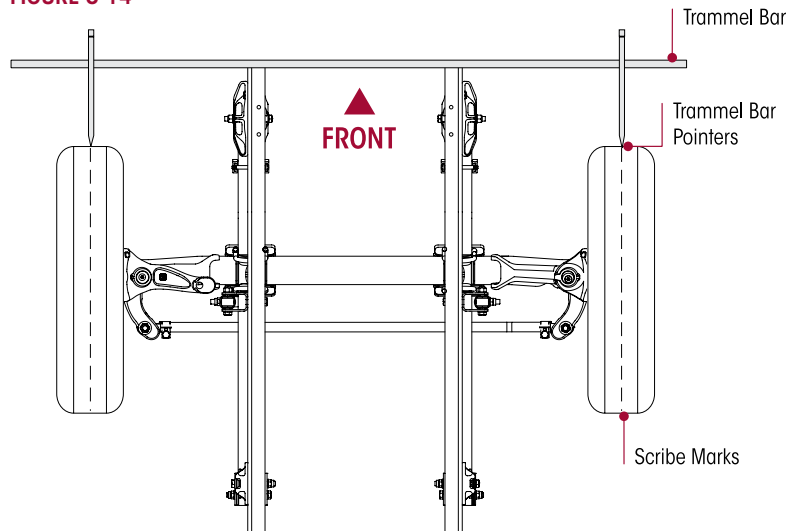

9. To calculate the toe setting subtract the front measurement from the rear measurement, the difference between the two will equal the toe-in/toe-out measurement.
10. If the toe measurement is not within the specifications of $\frac{1}{16}'' \pm \frac{1}{32}''$ ($0.060'' \pm 0.030''$), it will be necessary to adjust the toe setting. Refer to the following procedure.
 - a. Loosen the tie rod cross tube clamp bolts and locknuts.
 - b. Turn the tie rod cross tube until the specified toe-in distance is achieved.
 - c. Tighten the bolt and locknut on the tie rod cross tube to $\boxed{68} \pm 7$ foot pounds torque.

WARNING

THE THREADED PORTION OF THE TIE ROD END MUST EXTEND PAST THE SLOTS INTO THE TIE ROD (SEE FIGURE 8-15) IT IS CRITICAL TO CHECK THE 5/8" TIE ROD CLAMP BOLT HEAD LOCATION TO VERIFY THE CLAMP FASTENERS HAVE SUFFICIENT CLEARANCE AWAY FROM THE LOWER SHOCK MOUNT AT FULL WHEEL CUT. THE FASTENERS MUST NOT CONTACT THE LOWER SHOCK MOUNT. FAILURE TO DO SO CAN CAUSE ONE OR MORE COMPONENTS TO FAIL CAUSING LOSS OF VEHICLE CONTROL AND POSSIBLE PERSONAL INJURY OR PROPERTY DAMAGE.

11. Verify the 5/8" tie rod clamp bolt head does not contact the lower shock mount at full wheel cut, see Figure 8-15.
12. Repeat Steps 1-10 until the correct toe setting is achieved.

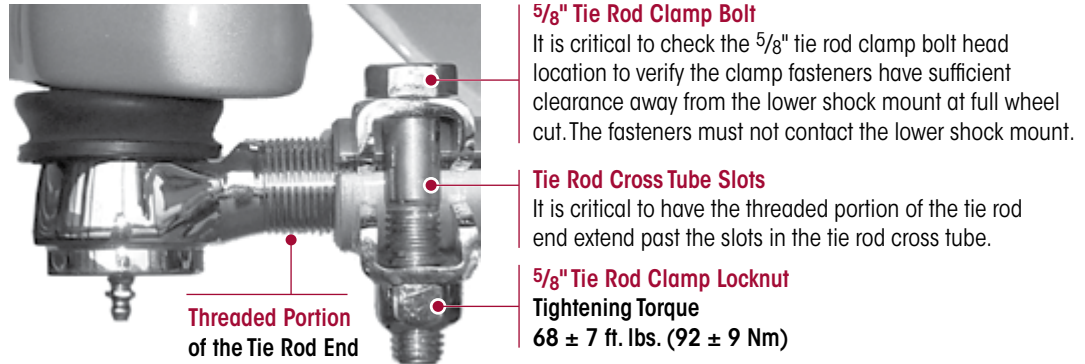
FIGURE 8-15

SPRING EYE RE-TORQUE

- This procedure to re-torque is necessary when replacing the: front hanger, shackle assembly and leaf spring assembly

RE-TORQUE PROCEDURE

1. Chock the rear wheels of the vehicle to prevent movement.
2. Verify ride height. Adjust if necessary as per vehicle manufacturer's specifications.

NOTE

DO NOT remove the spring eye bolts.

3. Loosen all six (6) front and rear spring eye bolts.
4. Let the suspension settle.
5. Tighten the front 3/4" spring eye bolt locknuts to 330 ± 10 foot pounds torque.
6. Tighten the rear 3/4" spring eye bolt locknuts to 330 ± 10 foot pounds torque.
7. Affix a straight edge to the bottom of the frame rail in front of the leaf spring, see Figure 8-16.
8. With the vehicle on a level surface measure the distance from the top of the straight edge to the ground on both sides of the vehicle and record the measurements.
9. Measure the difference from one side to the other.
10. Do a road test and repeat measurement Steps 7 to 9.
11. If the measurement is less than 3/8" the vehicle is level. If measurement is more than 3/8" contact Hendrickson Tech Services.

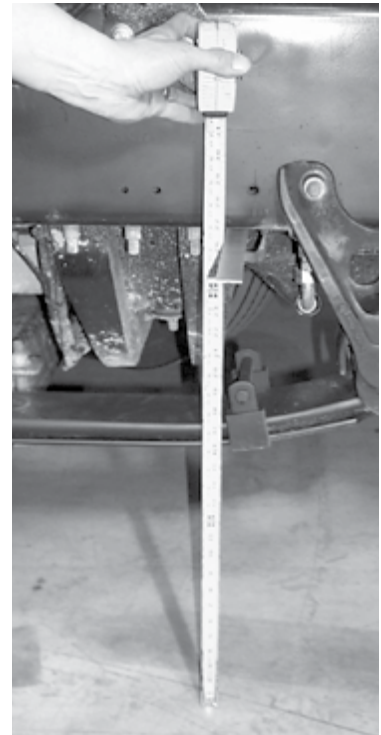
FIGURE 8-16

SECTION 9

Component Replacement

FASTENERS

Hendrickson recommends that when servicing the vehicle to replace the removed fasteners with new equivalent fasteners. Maintain correct torque values at all times. Check torque values as specified. See Hendrickson's Torque Specifications in the Appendix of this publication. If non-Hendrickson fasteners are used follow torque specifications listed in the vehicle manufacturer's service manual.

FRONT LEAF SPRING EYE BUSHINGS

The spring eye bushings for the SOFTEK leaf spring is designed to provide extended service life. If premature wear occurs careful consideration must be given to the contributing factor that caused the wear. This must be corrected in order to prevent the new bushing from wearing in the same manner. The front and rear bushings are permanently installed in the spring leaf and are not serviceable. If a bushing wears prematurely, the leaf spring assembly must be replaced. Follow the procedure for the Leaf Spring Assembly in this Section.

FRAME HANGER

DISASSEMBLY

1. Place the vehicle on level floor.
2. Chock the wheels.
3. Raise the frame.
4. Support the vehicle with frame stands.
5. Suspend the front axle from the shock absorbers.
6. Remove and discard the $\frac{3}{4}$ " spring eye fasteners.

SERVICE HINT

A bottle jack may be required to raise the axle slightly to facilitate removal of the spring eye bolt.

7. Remove the frame mounting fasteners from the hanger per manufacturer's guidelines.
8. Remove the hanger from the vehicle, see Figure 9-1.

ASSEMBLY

1. Install the new hanger on the frame.
2. Install new frame fasteners per manufacturer's guidelines.
3. Install the new $\frac{3}{4}$ " spring eye fasteners, see Figure 9-1.
4. Remove the frame stands and lower frame.
5. Tighten the $\frac{3}{4}$ " locknut to  330 ± 10 foot pounds torque.
6. Remove the wheel chocks.

FIGURE 9-1



REAR SHACKLE BRACKET

DISASSEMBLY

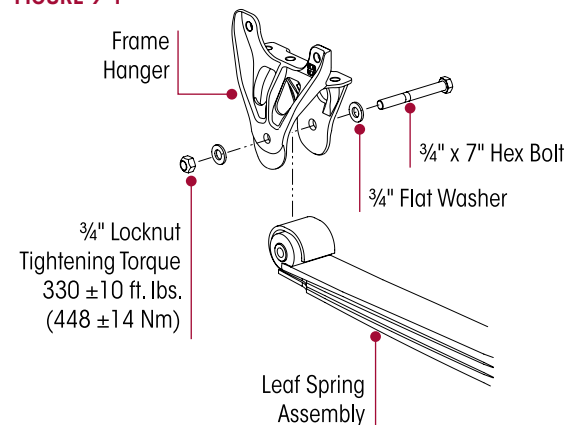
1. Place the vehicle on level floor.
2. Chock the wheels.
3. Raise the frame.
4. Support the vehicle with frame stands.
5. Suspend the front axle from the shock absorbers.
6. Remove and discard the rear $\frac{3}{4}$ " spring eye and shackle fasteners.

SERVICE HINT

A bottle jack may be required to raise the axle slightly to facilitate removal of the spring eye bolt.

7. Remove the frame fasteners from the shackle bracket per manufacturer's guidelines.
8. Remove the shackle bracket from the vehicle, see Figure 9-2.
9. Inspect the shackle bracket and shackle plate for excessive wear or damage.

ASSEMBLY

1. Install the shackle bracket on the frame.
2. Install new frame fasteners per manufacturer's guidelines.
3. Install the shackle plate with the new $\frac{3}{4}$ " fasteners. Snug the shackle bolts. **DO NOT** tighten at this time.
4. Remove the frame stands and lower frame.
5. Tighten the $\frac{3}{4}$ " shackle locknuts to 330 ± 10 foot pounds torque, see Figure 9-2.
6. Remove the wheel chocks.

FIGURE 9-2

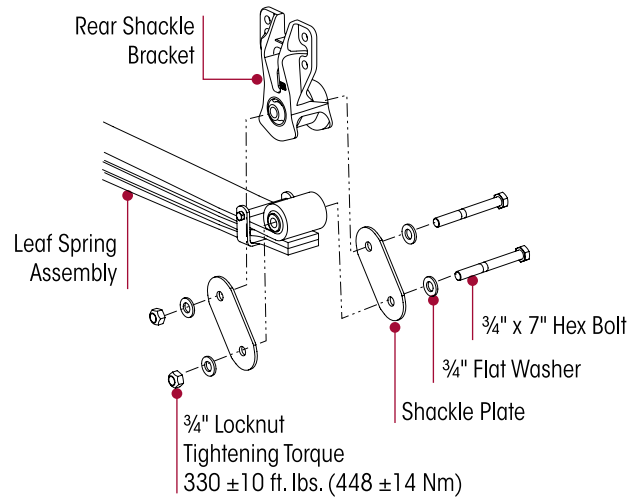

RUBBER AXLE STOP

REMOVAL

1. Insert a small pry bar between the rubber stop and the inside of the top pad.
2. Apply downward force on the pry bar and pull the rubber stop out of the top pad, see Figure 9-3.
3. Inspect the top pad and frame rail flange for any contact damage.
4. Clean any debris from inside the top pad.

INSTALLATION

1. Lubricate the new rubber axle stop with soapy water.
2. Install the rubber axle stop in the top pad.
3. Apply downward force on the rubber axle stop until it is seated firmly in the top pad.

FIGURE 9-3

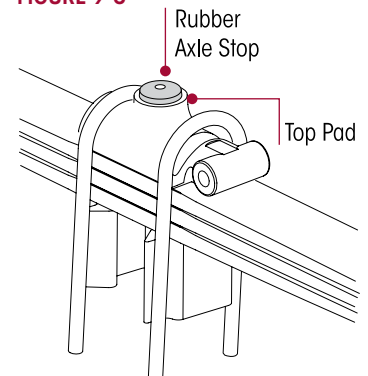

SHOCK ABSORBER

NOTE

It is not necessary to replace the shock absorber in pairs if only one (1) shock absorber requires replacement.

WARNING

THE SHOCK ABSORBERS ARE THE REBOUND TRAVEL STOPS FOR THE SPRINGS. ANYTIME THE FRONT AXLE ON SOFTEK SUSPENSION IS SUSPENDED IT IS MANDATORY THAT THE SHOCK ABSORBERS REMAIN CONNECTED. FAILURE TO DO SO COULD CAUSE THE LEAF SPRINGS TO EXCEED THEIR MAXIMUM LENGTH, OR CAUSE A REVERSE ARCH IN THE STEEL LEAF SPRINGS, POSSIBLY RESULTING IN PREMATURE STEEL LEAF SPRING FAILURE.

FIGURE 9-4

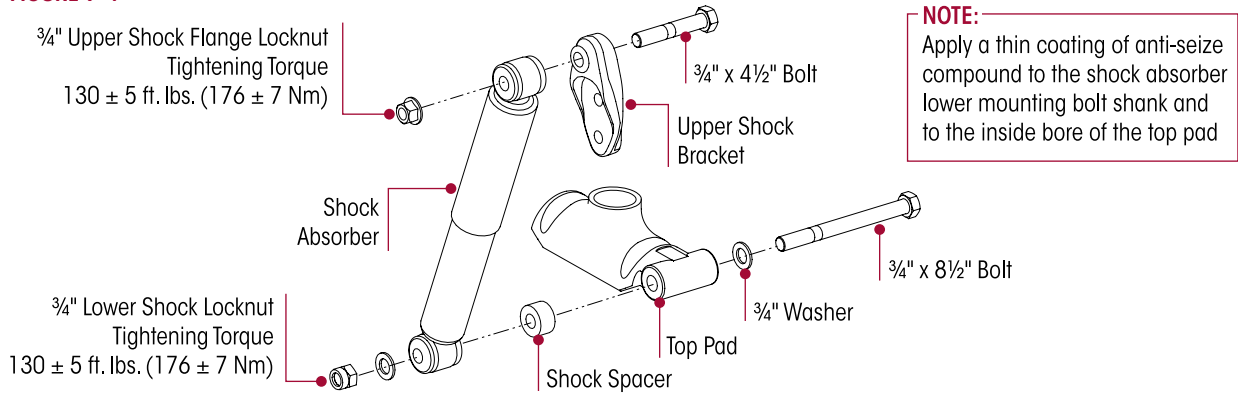

NOTE:

Apply a thin coating of anti-seize compound to the shock absorber lower mounting bolt shank and to the inside bore of the top pad

DISASSEMBLY

1. Remove the $\frac{3}{4}$ " lower mounting bolt, fasteners, and spacer.
2. Remove the $\frac{3}{4}$ " upper mounting bolt and fasteners.
3. Slide the shock absorber out of the toppad and off of the lower mounting bolt.
4. Inspect the shock absorber mounting brackets and hardware for damage or wear, replace as necessary.

ASSEMBLY

1. Install the shock absorber into the upper mounting bracket.
2. Install the upper $\frac{3}{4}$ " shock mounting fasteners.
3. Apply a thin coating of anti-seize compound to the shock absorber lower mounting bolt shank and to the inside bore of the top pad to help prevent seizing of the bolt to the top pad.
4. Install the lower bolt from the inboard side to the outboard side of the top pad and attach the shock spacer and fasteners, see Figure 9-4.
5. Tighten both upper and lower $\frac{3}{4}$ " locknuts to 130 ± 5 foot pounds torque, see Figure 9-4.

LEAF SPRING ASSEMBLY

DISASSEMBLY

1. Place the vehicle on a level floor.
2. Chock the wheels.
3. Raise the vehicle.
4. Install a floor jack with a 4 inch lifting plate below the axle and raise the truck.
5. Remove the tires.
6. Install frame stands behind the rear spring mounts. It may be necessary to remove peripheral components for installation of the frame stands.
7. Lower the jack allowing the axle to hang, but **DO NOT** remove the jack from the axle.

8. Loosen both front spring eye bolts, but **DO NOT** remove the bolts.
9. Loosen the ¾" shackle pivot bolt.
10. Remove both rear spring eye bolts.
11. Remove both lower shock absorber mounting fasteners.

SERVICE HINT

To ease in the removal of the spring eye bolts, it may be necessary to raise or lower the axle slightly.

12. Suspend the front axle to remove the load from leaf spring assembly.
13. Remove the front and rear ¾" spring eye bolts and fasteners.

WARNING

DO NOT USE A CUTTING TORCH TO REMOVE CLAMP GROUP BOLTS OR ATTACHING FASTENERS. THE USE OF SUCH HEAT ON SUSPENSION COMPONENTS CAN ADVERSELY AFFECT THE STRENGTH OF THESE PARTS. A COMPONENT DAMAGED IN THIS MANNER CAN RESULT IN THE LOSS OF VEHICLE CONTROL AND POSSIBLE PERSONAL INJURY OR PROPERTY DAMAGE.

SERVICE HINT

If a clamp group nut fails to come off bolt, cut half way through the bolt with an abrasive cut off wheel, taking care not to contact axle beam or other components. Using an impact wrench, spin the locknut to fracture the bolt and remove.

14. Loosen the clamp group locknuts for the leaf spring that **IS NOT** being replaced.
15. Lower the jack allowing the suspension to pivot down out of the rear hanger clamps.
16. Remove the clamp group fasteners from the leaf spring being replaced and discard.

WARNING

UNAUTHORIZED TAMPERING OF INTEGRATED AXLE SPRING SEATS CAN CAUSE COMPONENT AND STRUCTURAL DAMAGE AND RESULT IN LOSS OF VEHICLE CONTROL, SEVERE PERSONAL INJURY OR DEATH, PROPERTY DAMAGE, AND WILL VOID ANY APPLICABLE WARRANTY.

- DO NOT REMOVE, MODIFY OR REPLACE INTEGRATED AXLE SPRING SEAT OR FASTENERS.

NOTE

Contact Hendrickson Tech Services for any questions regarding STEERTEK NXT axle spring seats and / or fasteners.

17. Remove the top pad, galvanized liner and front axle spacer from the leaf spring assembly that is going to be removed, see Figure 9-5.

ASSEMBLY

1. Install the new leaf spring assembly with the galvanized liner on the axle. Verify that the dowel pin is engaged properly in the axle spring seat/top wrap, see Figure 9-5.
2. Install the FRONT spring eye bolt and fastener, snug but **DO NOT** tighten at this time.
3. Install the top pad on top of the leaf spring.
4. Install the new clamp group fasteners. New clamp group fasteners must be used when the clamp group is removed, to prevent premature bolt fatigue.
5. Snug the clamp group, **DO NOT** tighten to torque at this time.
6. Raise the axle and the REAR spring assemblies into the rear shackle bracket.
7. Install the rear spring eye bolts in the rear shackle bracket, snug but **DO NOT** tighten at this time, see Figure 9-5.
8. Install the lower shock mounting bolts from the inboard side to the outboard side, snug bolts.
9. Install tires.
10. Lower the floor jack and set truck on ground.

IMPORTANT NOTE

Only the weight of the axle should be on the spring at the time of the front and rear spring eye tightening torque. See the Spring Eye Re-torque procedure in the Alignment & Adjustments Section of this publication.

11. Tighten the lower shock mounting fasteners to 130 ± 5 foot pounds torque.

FIGURE 9-5

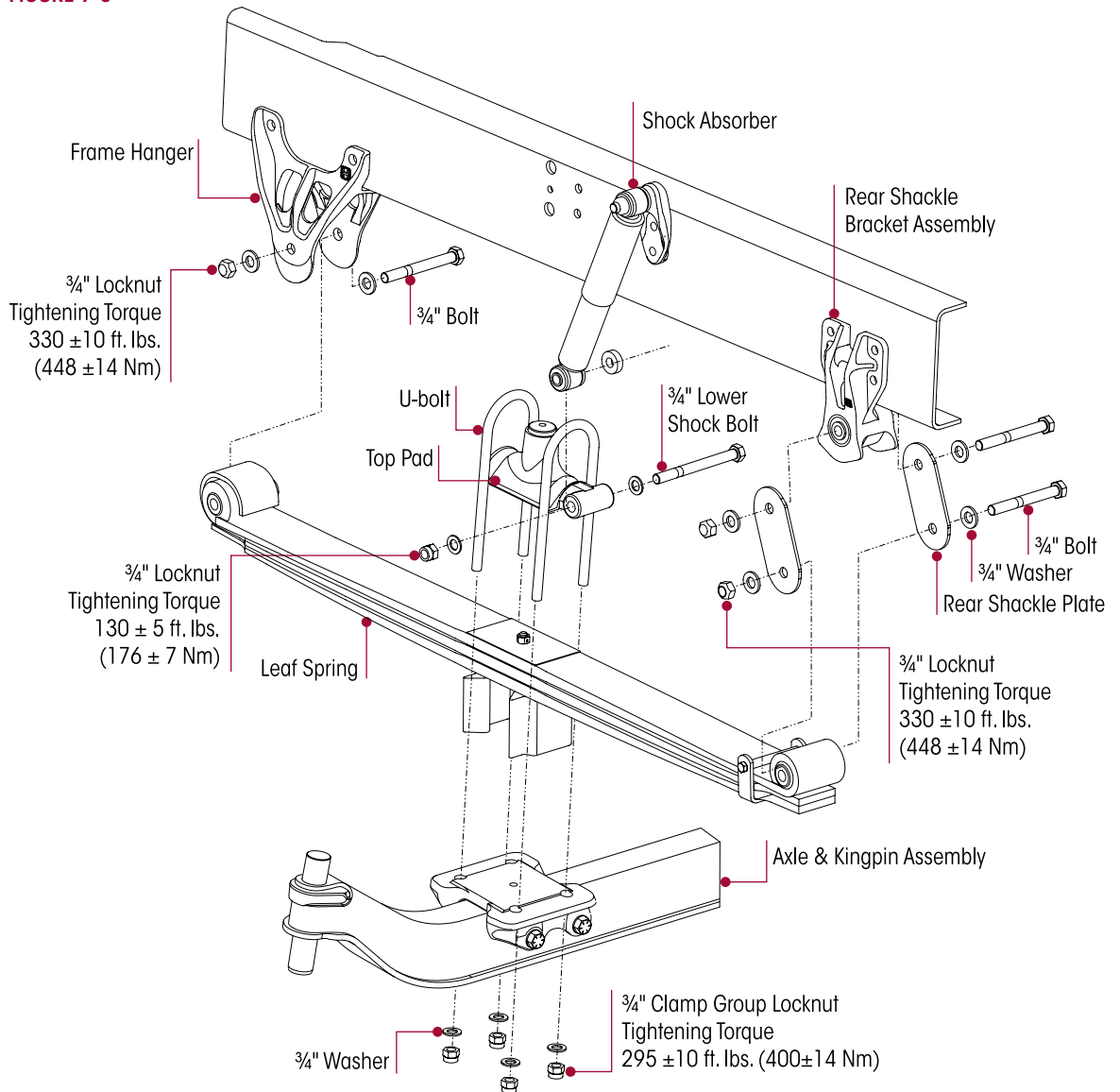

12. Tighten the front and rear spring eye fasteners to 330 ± 10 foot pounds torque.
13. Ensure that the clamp group is properly aligned and the U-bolts are seated in top pad, see Figure 9-6.
14. Tighten the clamp group locknuts evenly in 50 foot pounds increments to 295 ± 10 foot pounds torque in the proper pattern to achieve uniform bolt tension, see Figure 9-7.
15. Remove the wheel chocks.

FIGURE 9-6

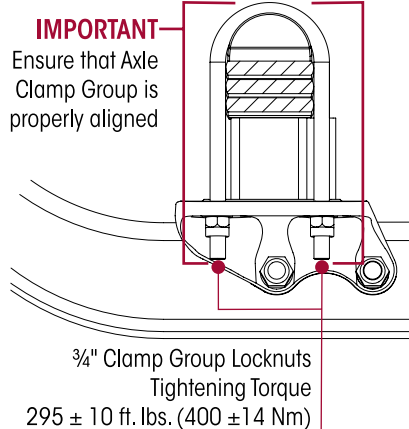
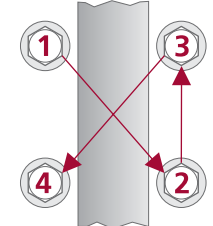

FIGURE 9-7





STEERTEK NXT AXLE

STEERTEK NXT AXLE REMOVAL

Refer to Figure 9-8 when replacing the components of the STEERTEK NXT axle.

FIGURE 9-8

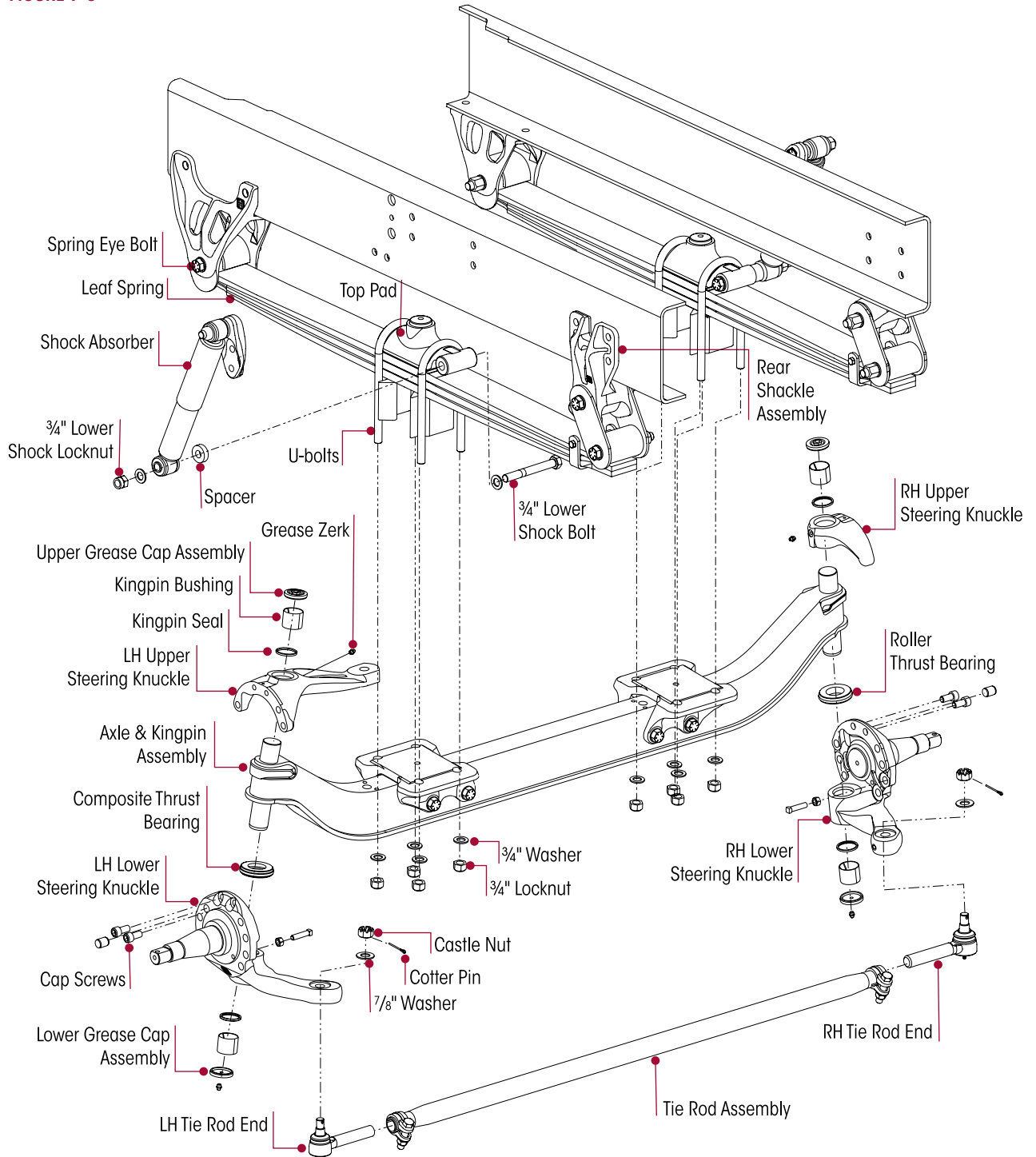



1. Place the vehicle on level floor.
2. Chock the wheels.

WARNING

DO NOT USE A TORCH ON CLAMP GROUP BOLTS OR ANY OTHER PART OF THE SOFTEK SUSPENSION. IF THE CLAMP GROUP BOLTS WILL NOT COME LOOSE WITH AN IMPACT WRENCH, USE A CUT OFF WHEEL AND CUT THE SHANK OF THE BOLT. THE USE OF A TORCH CAN CAUSE DAMAGE TO CERTAIN SOFTEK COMPONENTS THAT CAN RESULT IN THE LOSS OF VEHICLE CONTROL AND POSSIBLE PERSONAL INJURY OR PROPERTY DAMAGE.

3. Raise the frame.
4. Support the vehicle with frame stands and suspend the front axle with the shocks attached.

WARNING

THE INTEGRATED AXLE SPRING SEATS ON THE STEERTEK NXT AXLE ARE NON-SERVICEABLE. UNAUTHORIZED TAMPERING OF INTEGRATED AXLE SPRING SEATS CAN CAUSE COMPONENT AND STRUCTURAL DAMAGE AND RESULT IN LOSS OF VEHICLE CONTROL, SEVERE PERSONAL INJURY OR DEATH, PROPERTY DAMAGE, AND WILL VOID ANY APPLICABLE WARRANTY. DO NOT REMOVE, MODIFY OR REPLACE INTEGRATED AXLE SPRING SEAT OR FASTENERS, SEE FIGURE 3-1.

5. Remove the front wheels, hubs, brake shoes, ABS sensors, and backing plate assembly.
6. Disconnect the drag link from the steering arm.
7. Support the axle with a floor jack.

WARNING

DO NOT REPAIR OR RECONDITION SUSPENSION OR AXLE COMPONENTS FOUND TO BE DAMAGED OR OUT OF SPECIFICATIONS. ALL SUCH DAMAGED OR OUT OF SPECIFICATION COMPONENTS MUST BE REPLACED. ALL MAJOR HENDRICKSON COMPONENTS ARE HEAT TREATED AND TEMPERED. SOFTEK NXT COMPONENTS CANNOT BE BENT, WELDED, HEATED, OR REPAIRED WITHOUT REDUCING THE STRENGTH OR LIFE OF THE COMPONENT. FAILURE TO FOLLOW THESE GUIDELINES CAN CAUSE LOSS OF VEHICLE CONTROL, AND POSSIBLE PERSONAL INJURY OR DEATH OR PROPERTY DAMAGE AND WILL VOID APPLICABLE WARRANTIES.

8. Disconnect and remove the lower shock mounting bolts and shock spacer.
9. Remove the 3/4" clamp group bolts and fasteners.
10. Lower the axle and remove from the vehicle.

AXLE DISASSEMBLY (REMOVED FROM CHASSIS)

1. Remove the tie rod assembly. See Tie Rod Disassembly in this section.

WARNING

REMOVAL OF THE CAP SCREWS WILL ALLOW THE STEERING KNUCKLE TO SEPARATE FROM THE AXLE. THE STEERING KNUCKLE MUST BE SUPPORTED BEFORE REMOVAL OF THESE TWO (2) CAP SCREWS. FAILURE TO DO SO CAN CAUSE COMPONENT DAMAGE OR PERSONAL INJURY.

2. Remove the two (2) 5/8" socket head cap screws from the steering knuckle assembly, see Figure 9-8.
3. Remove the steering knuckle and thrust bearing.
4. After complete removal of the one side, repeat steps 1-3 for the opposite side of the axle.
5. Inspect the steering kingpin bushings for excessive wear. If worn, replace the kingpin bushings and seals. See the Kingpin Bushing replacement instructions in this section.

STEERTEK NXT AXLE INSTALLATION

1. Place the new axle on the floor jack and position the axle under the vehicle, see Figure 9-9
2. Raise the axle into position.
3. Ensure the front leaf spring assembly's center bolt is aligned correctly in the axle spring seat, see Figures 9-9.

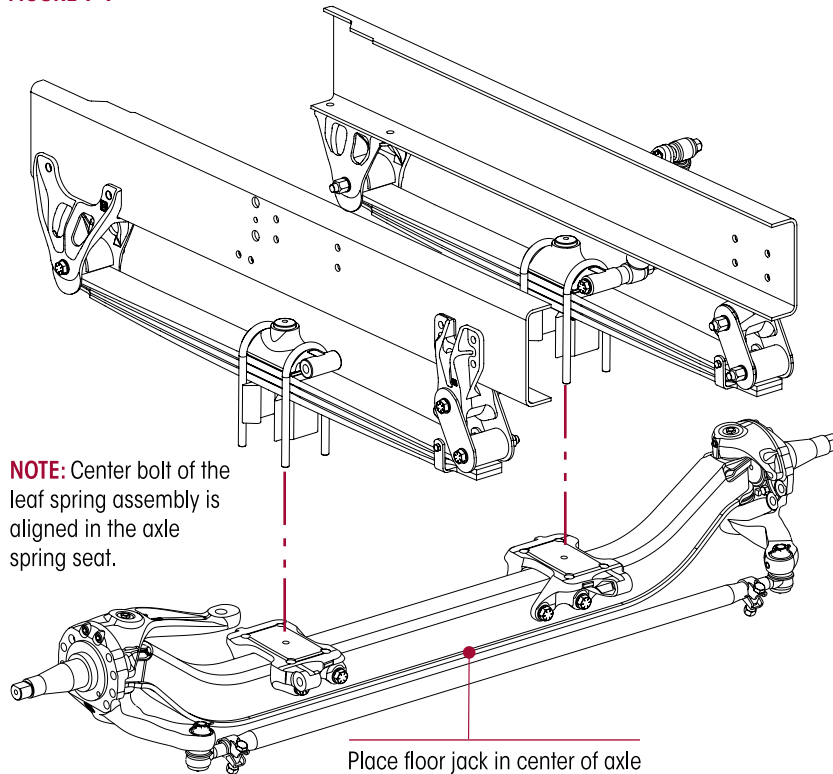
FIGURE 9-9

4. Install the galvanized liner between the main spring and the top pad, see Figure 9-8.
5. Install the new clamp group fasteners. **DO NOT** tighten to torque at this time.

FIGURE 9-10

IMPORTANT
Ensure that Axle Clamp Group is properly aligned

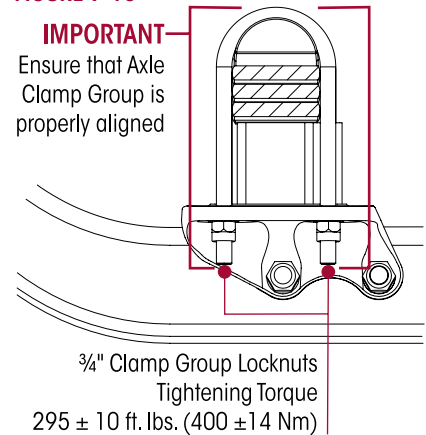
WARNING

ENSURE THE CLAMP GROUP IS ALIGNED PROPERLY PRIOR TO TIGHTENING HARDWARE. FAILURE TO DO SO CAN CAUSE LOSS OF VEHICLE CONTROL, PROPERTY DAMAGE OR PERSONAL INJURY.

6. Ensure the clamp group is properly aligned and the U-bolts are seated in the top pad, and the top pad is centered on the axle spring seat, see Figure 9-10.
7. Snug the clamp group fasteners to 100 foot pounds pre-torque.
8. Install the steering knuckles as per the Steering Knuckle Assembly instructions in this section.
9. Install the tie rod assembly in the Ackermann arms.
10. Install the $\frac{7}{8}$ " hardened washers on the Ackermann arm and the castle nuts. Tighten the castle nuts to 185 foot pounds, then rotate until the first castle slot lines up with the cotter pin bore in the tie rod end. **DO NOT** back off nut for cotter pin installation.
11. Install the tie rod end cotter pin.

12. Connect the drag link in the steering arm.
13. Install the castle nut on the drag link taper stud. Tighten the castle nut to 185 foot pounds, then rotate until the first castle slot lines up with the cotter pin bore in the drag link. **DO NOT** back off nut for cotter pin installation.
14. Install the drag link cotter pin.
15. Install and tighten the lower shock mounting bolts and spacer to 130 ± 5 foot pounds torque.
16. Install the brake backing plate assemblies and ABS sensor and torque all fasteners per manufacturer's specifications.
17. Install the brakes, hubs, and wheels per the manufacturer's guidelines.
18. Raise the vehicle and remove the frame supports.

19. Lower the floor jack and load the front axle with the truck's weight. Remove the floor jack.
20. Tighten the clamp group locknuts evenly in 50 foot pounds increments to 295 ± 10 foot pounds torque in the proper pattern to achieve uniform bolt tension, see Figure 9-11.
21. Remove the wheel chocks.
22. Fill the hubs with the proper lubricant, (see manufacturer's guidelines for recommended lubrication), if required.
23. Grease the front steering components as per lubrication guidelines in the Preventive Maintenance Section of this publication.

FIGURE 9-11

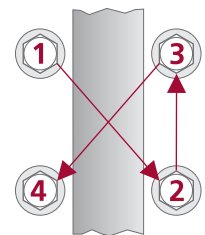

STEERING KNUCKLE

You will need:

Refer to the Special Tools Section of this publication.

- Kingpin Bushing and Seal Installer/Remover, Driver and Receiver Tool
- Adjustable Straight Flute Reamer

NOTE

Steering knuckle component replacement includes kingpin preparation and measurement, kingpin bushing removal, steering knuckle bore measurement, kingpin bushing installation, reaming, and kingpin seal installation.

DISASSEMBLY

1. Place the vehicle on level floor.
2. Chock the wheels.
3. Support the vehicle with jack stands on the axle.
4. Remove the wheel and hub assembly.
5. Remove the brake components from steering knuckle.
6. Remove the tie rod assembly.

FIGURE 9-12

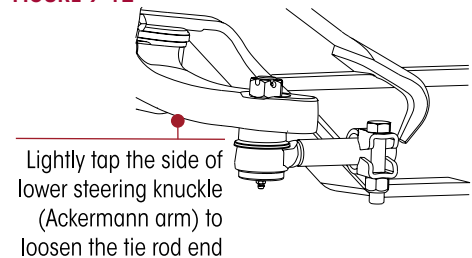

SERVICE HINT

Lightly tap the side of the Ackermann arm with a mallet to separate the tie rod end from the Ackermann arm, see Figure 9-12.

7. Remove the drag link from the knuckle if necessary.

WARNING

REMOVAL OF THE CAP SCREWS WILL ALLOW THE STEERING KNUCKLE TO SEPARATE FROM THE AXLE. THE STEERING KNUCKLE MUST BE SUPPORTED BEFORE REMOVAL OF THESE TWO (2) CAP SCREWS. FAILURE TO DO SO CAN CAUSE COMPONENT DAMAGE OR PERSONAL INJURY.

8. Remove two socket head cap screws that connect upper kingpin connection to the steering knuckle, see Figure 9-13.

FIGURE 9-13

SERVICE HINT

Remove the grease zerks from the knuckle assemblies. This will allow the knuckle assemblies to freely slide up and down the kingpins without creating back pressure.

9. Remove the lower steering knuckle from the kingpin by sliding it down the kingpin.
10. Remove the upper steering knuckle by sliding it up off the kingpin.

KINGPIN

PREPARATION AND MEASUREMENT

Cleaning the Ground and Polished Parts

- Use a cleaning solvent to clean ground or polished parts and surfaces. **DO NOT USE GASOLINE.**
- **DO NOT** clean ground or polished parts in a hot solution tank or with water, steam, or alkaline solutions. These solutions will cause corrosion of the parts.

Cleaning the Rough Parts

- Rough parts can be cleaned with the ground or polished parts. Rough parts can also be cleaned in hot solution tanks with a weak alkaline solution. The parts must remain in the hot solution tanks until they are completely cleaned and heated.

Drying the Cleaned Parts

- Parts must be dried immediately after cleaning. Dry the parts with clean paper towels, clean rags, or compressed air. **DO NOT** dry bearings by spinning with compressed air. Damage to the bearings will result.

Preventing Corrosion on Cleaned Parts

- Apply a light coating of oil to all cleaned and dried parts that are going to be reused. **DO NOT** apply oil to the brake lining or the brake drums. If parts are to be stored, apply an effective rust inhibitor to all surfaces.

WARNING

TO HELP PREVENT SERIOUS EYE INJURY, ALWAYS WEAR PROPER EYE PROTECTION WHEN YOU PERFORM VEHICLE MAINTENANCE OR SERVICE.

WARNING

SOLVENT CLEANERS CAN BE FLAMMABLE, POISONOUS AND CAUSE BURNS. TO HELP AVOID SERIOUS PERSONAL INJURY, CAREFULLY FOLLOW THE MANUFACTURER'S PRODUCT INSTRUCTIONS AND GUIDELINES AND THE FOLLOWING PROCEDURES:

- WEAR PROPER EYE PROTECTION
- WEAR CLOTHING THAT PROTECTS YOUR SKIN
- WORK IN A WELL VENTILATED AREA
- DO NOT USE GASOLINE, SOLVENTS OR OTHER MATERIALS THAT CONTAIN GASOLINE THAT CAN EXPLODE



- HOT SOLUTION TANKS OR ALKALINE SOLUTIONS MUST BE USED CORRECTLY. FOLLOW THE MANUFACTURER’S RECOMMENDED INSTRUCTIONS AND GUIDELINES CAREFULLY TO HELP PREVENT PERSONAL ACCIDENT OR INJURY.



DO NOT USE HOT SOLUTION TANKS OR WATER AND ALKALINE SOLUTIONS TO CLEAN GROUND OR POLISHED PARTS. DAMAGE TO THE PARTS WILL RESULT.



THE STEERTEK NXT HAS A UNIQUE AXLE. THE KINGPIN IS CRYOGENICALLY INSTALLED IN THE AXLE. THE KINGPIN IS A NON-REPLACEABLE COMPONENT OF THE AXLE ASSEMBLY. DO NOT TRY TO REMOVE THE KINGPIN. DOING SO WILL DAMAGE THE AXLE AND MAY CAUSE LOSS OF VEHICLE CONTROL, PERSONAL INJURY OR PROPERTY DAMAGE. IF THE KINGPIN SHOWS SIGNS OF MOVEMENT, CONTACT HENDRICKSON PRODUCT ENGINEERING - TECH SERVICES.

1. Prepare and polish the kingpin by removing all grease and excess debris using a fine grit (220 grit or higher) emery cloth and parts solvent, see Figures 9-14 through 9-17.

FIGURE 9-14



FIGURE 9-15



FIGURE 9-16



FIGURE 9-17



2. Inspect the kingpin for wear or damage. Use a micrometer and measure the upper and lower kingpin in two locations. Positions must be 90° opposed from each other. If the kingpin has less than 1.802" diameter, replacement of the axle is necessary, see Figures 9-18 through 9-21. **Kingpin minimum dimension is 1.802".**

FIGURE 9-18



FIGURE 9-19



FIGURE 9-20



FIGURE 9-21



KINGPIN BUSHING

WARNING

BEFORE APPLYING HYDRAULIC PRESSURE TO ANY TOOLING SET-UP, ALWAYS CHECK TO ENSURE THE PRESS PLATE, TOOLS, AND COMPONENTS BEING WORKED ON ARE POSITIONED PROPERLY, I.E. "IN LINE" WITH THE RAM OF THE PRESS. IMPROPER POSITIONING CAN CAUSE PERSONAL INJURY OR COMPONENT DAMAGE.

CAUTION

PRIOR TO APPLYING HYDRAULIC PRESSURE TO REMOVE OR INSTALL THE KINGPIN BUSHING, SUPPORT THE LOWER STEERING KNUCKLE AS SHOWN IN FIGURE 9-22. IMPROPER SUPPORT TO THE STEERING KNUCKLE CAN CAUSE COMPONENT DAMAGE.

REMOVAL

You will need:

Refer to the Special Tools Section of this publication.

- A hydraulic shop press with a minimum forcing capacity of 2.5 tons (or an arbor press) or optional method - use hand tools
- Kingpin handle, bushing installer/remover, driver and receiving tool

NOTE

If a shop press is not available to remove / install the kingpin bushings, an acceptable optional method is to use a hammer along with the shop made tools (kingpin bushing driver, receiving tool, kingpin handle, bushing installer / remover and seal installer tools) on a work bench.

NOTE

To remove the kingpin bushing, always drive the bushing from the non-machined side of the steering knuckle.

FIGURE 9-22



FIGURE 9-23



FIGURE 9-24



FIGURE 9-25



1. Remove the threaded grease cap and grease zerk.
2. With the machined side of the steering knuckle face down (axle side down), ensure that each part of the steering knuckle assembly is squarely supported on the bushing receiving tool before applying hydraulic pressure to press out the kingpin bushings, see Figures 9-22 and 9-23.
3. From the non-machined side of the steering knuckle, use the kingpin bushing installer/remover tool (see Special Tools Section of this publication) to drive the kingpin bushing and kingpin seal out of the steering knuckle, see Figure 9-24.
4. Clean the parts and inspect for reassembly, see Figure 9-25.

STEERING KNUCKLE BORE MEASUREMENT

Complete the following steering knuckle bore inspection and the measurement instructions prior to installing the kingpin bushing.

1. Measure the upper knuckle bore inside diameter at two locations. Always use an inside micrometer or a telescoping gauge when taking a knuckle bore measurement. Some out-of-roundness at the top and bottom of the bore edges is acceptable. Steering knuckle bore diameter is $1.938" \pm 0.003"$.
2. Measure the upper and lower bore in two positions and at two locations. The two positions must be 90° opposed from each other, see Figures 9-26 through 9-28. If the average measurement is more than the knuckle bore maximum diameter specification, replace the knuckle.

FIGURE 9-26



FIGURE 9-27



FIGURE 9-28



KINGPIN BUSHING INSTALLATION

You will need:

Refer to the Special Tools Section of this publication.

- Kingpin Bushing and Seal Installer/Remover, Driver and Receiver Tool
- Adjustable Straight Flute Reamer
- A hydraulic shop press with a minimum forcing capacity of 2.5 tons

WARNING

BEFORE APPLYING HYDRAULIC PRESSURE TO ANY TOOLING SET-UP, ALWAYS CHECK TO ENSURE THE PRESS PLATE, TOOLS, AND COMPONENTS BEING WORKED ON ARE POSITIONED PROPERLY, I.E. "IN LINE" WITH THE RAM OF THE PRESS. IMPROPER POSITIONING CAN CAUSE PERSONAL INJURY OR COMPONENT DAMAGE.

NOTE

If a shop press is not available to remove / install the kingpin bushings, an acceptable optional method is to use a hammer along with the shop made tools (kingpin bushing driver, receiving tool, kingpin handle, bushing installer / remover and seal installer tools) on a work bench.

1. With the machined side of the steering knuckle face up (axle side up), ensure that each part of the steering knuckle assembly is squarely supported before applying hydraulic pressure to press in the kingpin bushing, see Figure 9-29.

NOTE

To install the kingpin bushing, always drive the bushing from the machined side of the steering knuckle.

2. From the machined side of the steering knuckle, use the kingpin bushing driver tool to drive the kingpin bushing flush into steering knuckle, see Figure 30.
3. Next, use the kingpin bushing installer/remover tool to sink the kingpin bushing into the steering knuckle bore to just below the seal bore, see Figure 31.
4. Following this procedure it is necessary to ream the kingpin bushings to fit the kingpins, see Kingpin Bushing Reaming instructions.

FIGURE 9-29

FIGURE 9-30

FIGURE 9-31

KINGPIN BUSHING REAMING

You will need:

- Vise with brass jaws (soft jaws)
- Adjustable Straight Flute Reamer, see Special Tools Section of this Publication.



REAM THE KINGPIN BUSHINGS WITH AN ADJUSTABLE STRAIGHT FLUTE REAMER, SEE SPECIAL TOOLS SECTION OF THIS PUBLICATION. DO NOT HONE OR BURNISH THE KINGPIN BUSHINGS. HONING OR BURNISHING WILL DAMAGE THE BUSHINGS AND VOID ANY APPLICABLE WARRANTY.



WHEN INSTALLING STEERING KNUCKLE COMPONENTS IN A VISE IT IS NECESSARY TO PROTECT THE MACHINED SURFACES FROM GOUGES OR MARRING BY USING BRASS JAWS (SOFT JAWS). FAILURE TO DO SO CAN CAUSE PREMATURE PART DAMAGE, DAMAGE TO THE STEERING KNUCKLE COMPONENTS, LOSS OF WARRANTY, LOSS OF VEHICLE CONTROL, CAUSING PERSONAL INJURY OR PROPERTY DAMAGE.

1. Install the lower steering knuckle assembly in a vise with brass jaws (soft jaws).

SERVICE HINT

It is acceptable to mount the knuckle components in a vise either vertically or horizontally when performing the reaming procedure.

2. Install the reamer into the lower steering knuckle until the blades touch the kingpin bushing.
3. Rotate the reamer with light downward pressure. Rotate the reamer smoothly. **DO NOT** apply too much pressure, see Figures 9-32 and 9-33.
4. Slide the reamer out of the bottom of the steering knuckle assembly. If it is necessary to remove the reamer from the top, rotate the reamer opposite of cutting rotation.

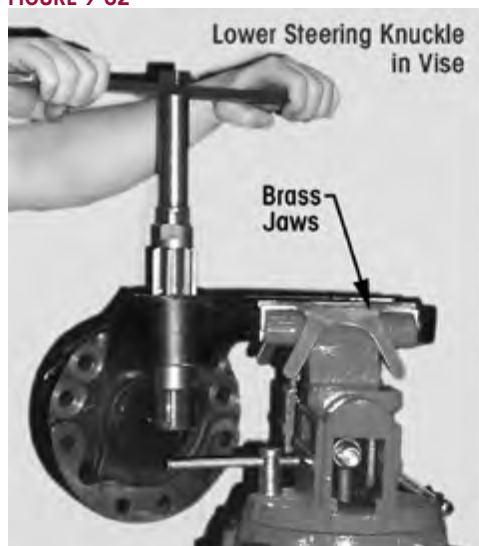
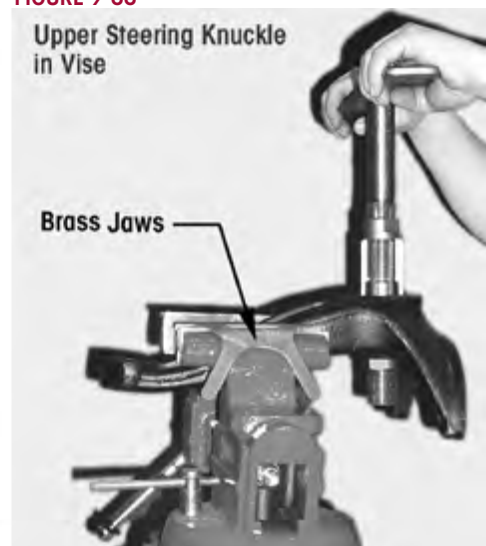
FIGURE 9-32

FIGURE 9-33

WARNING

PRIOR TO INSTALLATION ENSURE THAT ALL RESIDUAL LOCTITE MATERIAL IS REMOVED FROM THE MOUNTING BOLTS AND THE THREAD BORES IN THE UPPER STEERING KNUCKLES, AND NEW LOCTITE 277 OR EQUIVALENT IS APPLIED TO HELP ENSURE THAT THE BOLTS SUSTAIN THE PROPER TORQUE REQUIREMENT. FAILURE TO DO SO CAN CAUSE LOSS OF VEHICLE CONTROL RESULTING IN PERSONAL INJURY OR PROPERTY DAMAGE.

5. Clean and remove all kingpin bushing material from the steering knuckle assembly. Take special attention to remove material from the grease channels and dimples.
6. Clean the $\frac{5}{8}$ " brake backing plate bolts with a wire wheel and run a tap through the threads of the lower steering knuckle assembly and then flush out with brake cleaner and dry with compressed air.

NOTE

The Hendrickson Genuine part, socket head cap screw comes with a pre-applied loctite compound.

7. Temporarily install the upper/lower knuckle on the kingpin to check for fit.
8. Rotate the upper/lower knuckle back and forth to verify there is no binding on the kingpin, see Figure 9-34.
9. If the bushing is too tight repeat Steps 1 through 8 until the proper clearance is achieved.

FIGURE 9-34

NOTE

Bushing size is to be 0.001" larger than the kingpin size.

10. Proceed to Kingpin Seal installation.

KINGPIN SEAL INSTALLATION
You will need:

- Vise with brass jaws (soft jaws)
- Kingpin handle and seal installer tool, see Special Tools Section of this publication.

WARNING

WHEN INSTALLING STEERING KNUCKLE COMPONENTS IN A VISE IT IS NECESSARY TO PROTECT THE MACHINED SURFACES FROM GOUGES OR MARRING BY USING BRASS JAWS (SOFT JAWS). FAILURE TO DO SO CAN CAUSE PREMATURE PART DAMAGE, DAMAGE TO THE STEERING KNUCKLE COMPONENTS, LOSS OF WARRANTY, LOSS OF VEHICLE CONTROL, CAUSING PERSONAL INJURY OR PROPERTY DAMAGE.

1. Place the steering knuckle assembly in a vise with brass jaws (soft jaws) or place on a suitable workbench. The steering knuckle will have the machined surface facing up (axle side up).
2. Lay the kingpin seal into the bore of the steering knuckle. The seal lip should face outward or toward the axle, see Figure 9-35.
3. Use the seal installer tool (see Special Tools Section of this publication) and press seal firmly into the steering knuckle assembly.
4. Install the double lip kingpin seal until it bottoms out in the kingpin bore, see Figure 9-36.

FIGURE 9-35
Magnification
of lip seal
 Lip seal faces
 toward axle

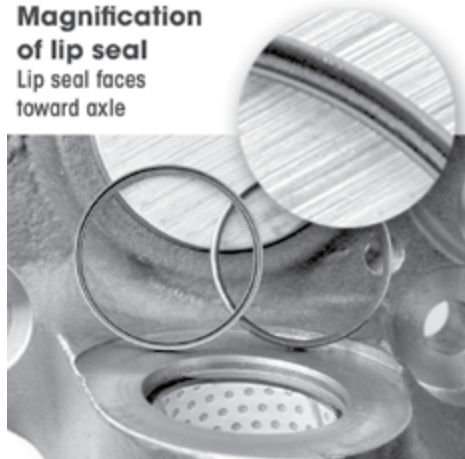

FIGURE 9-36
STEERTEK NXT
 Magnification of the
 kingpin bushing
 and a **DOUBLE**
 lip seal installed in
 the steering knuckle.



STEERING KNUCKLE

ASSEMBLY

After replacement of the kingpin bushings it is necessary to re-assemble the steering knuckle assemblies. **DO NOT** substitute aftermarket components when servicing.

FIGURE 9-37
 Black Seal



Seal



Top View of Thrust Bearings

COMPOSITE THRUST BEARING

ROLLER THRUST BEARING

Left Side

Right Side

NOTE

Hendrickson STEERTEK NXT axle is installed with a left hand composite bearing and a right hand roller bearing configuration.

1. Install the composite thrust bearing on the lower kingpin on the left side and the roller thrust bearing on the right side with the seal facing up toward axle (the black seal will designate the top side), see Figure 9-37.
2. Pack the bushing dimples on the upper and lower steering knuckles with multi purpose Lithium based grease (NLGI Grade 2) before installation.
3. Install the upper steering knuckle on the upper arm kingpin.
4. Install the lower steering knuckle on the lower kingpin and install the old socket head cap screws loose into the top two (2) threaded holes.
5. Install a bottle jack under the lower knuckle and slightly raise the knuckle until it is possible to thread in the three (3) brake backing plate bolts by hand. These are for guide purposes only.
6. Snug the two socket head cap screws.
7. Lower the bottle jack so that all the vertical end play is on the underside of the axle.
8. Affix a magnetic base dial indicator on the axle and place the tip of the dial indicator on top of the knuckle assembly, see Figure 9-38.
9. Zero the dial indicator.
10. Raise the bottle jack until there is **NO CLEARANCE** between the knuckle assembly and the bottom of the axle, slightly lifting the axle.

FIGURE 9-38

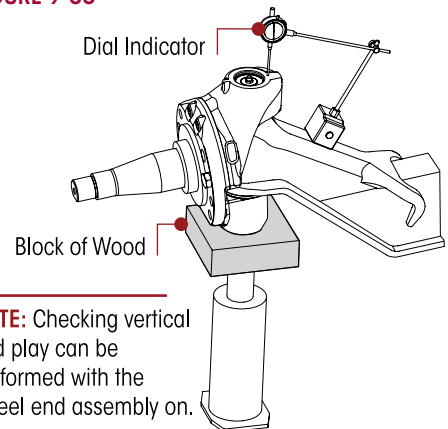

NOTE: Checking vertical end play can be performed with the wheel end assembly on.

11. Check the reading on the dial indicator. The specification for vertical travel on the steering knuckle during assembly is 0.008" to 0.011".
12. If the clearance is:
 - **Above 0.011"**, loosen the socket head cap screws and **push down** on the knuckle assembly until the proper vertical end play is achieved.
 - **Below 0.008"**, loosen the socket head cap screws and **pull up** on the knuckle assembly until the proper vertical end play is achieved.

NOTE

The Hendrickson Genuine part, socket head cap screw comes with a pre-applied Loctite compound.

 **WARNING**

PRIOR TO INSTALLATION ENSURE THAT ALL RESIDUAL LOCTITE MATERIAL IS REMOVED FROM THE MOUNTING BOLTS AND THE THREAD BORES IN THE UPPER STEERING KNUCKLE, AND NEW LOCTITE 277 OR EQUIVALENT IS APPLIED TO HELP ENSURE THAT THE BOLTS SUSTAIN THE PROPER TORQUE REQUIREMENT. FAILURE TO DO SO CAN CAUSE LOSS OF VEHICLE CONTROL RESULTING IN PERSONAL INJURY OR PROPERTY DAMAGE.

13. Remove one (1) old socket head cap screw and replace with new socket head cap screw.
14. Remove second socket head cap screw and replace with new socket head cap screw. Tighten both socket head cap screws to  188 ± 12 foot pounds torque.
15. Recheck the vertical end play with the dial indicator, see Figure 9-38 or a 0.010" feeler gauge.
16. Remove the brake spider bolts, they should thread out freely.
17. Remove the bottle jack and continue assembling the wheel ends.

IMPORTANT NOTE

It is critical to apply Loctite to the three (3) brake spider bolts to ensure that these bolts sustain the proper torque requirement of steering knuckle assembly.

18. Apply loctite to the three (3) brake spider bolts prior to installation into the brake spider. Tighten bolts to  188 ± 12 foot pounds torque.

 **WARNING**

DO NOT GREASE KNUCKLES WITHOUT THE BRAKE SPIDER INSTALLED AND TIGHTENED TO PROPER TORQUE. FAILURE TO DO SO CAN CAUSE COMPONENT DAMAGE RESULTING IN FAILURE AND LOSS OF VEHICLE CONTROL, POSSIBLY CAUSING PERSONAL INJURY OR PROPERTY DAMAGE.



19. Install the tie rod end into the lower steering knuckle arm.
20. Tighten the castle nuts to  185 foot pounds torque then rotate the castle nut to the next castle slot and install cotter pin.
21. Install the drag link into the steering arm and tighten to the vehicle manufacturer's specifications.
22. Install new grease caps. Note the grease caps on the STEERTEK NXT axle are threaded, tighten to  60 ± 10 foot pounds torque., see Figure 9-39.
23. Allow 30 minutes for thread sealant to cure before greasing. Install new grease zerk and tighten to a minimum of  15 foot pounds, see Figure 9-39.

FIGURE 9-39**STEERTEK NXT**

Grease Zerk
Tightening Torque
minimum of 15 ft. lbs.

Grease Cap Threads
Tightening Torque 60 ± 10 ft. lbs.

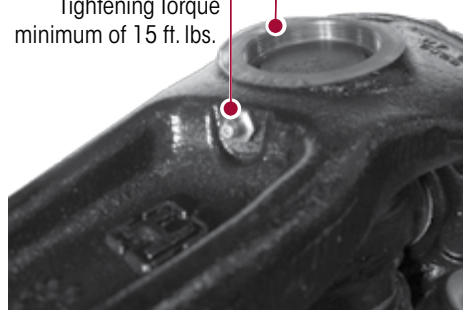

24. Install brakes, drums, wheels and tires.
25. Remove jack and safety stands.
26. Grease steering knuckles with the vehicle on the floor.
27. Remove the wheel chocks.

TIE ROD END AND CROSS TUBE

NOTE:

Hendrickson supplies different tie rod configurations. Prior to ordering find the part number on the tie rod tube. See Hendrickson Technical Bulletin Literature No. SEU-0223 for additional information or contact Hendrickson Truck Parts (e-mail: truckparts@hendrickson-intl.com).

DISASSEMBLY

1. Chock the wheels.
2. Position the steer axle tires straight ahead.
3. Remove the cotter pin and castle nut.
4. Lightly tap the side of the Ackermann arm to loosen the tie rod end from the Ackermann arm, see Figure 9-40.
5. Repeat to Steps 3 and 4 to remove the other tie rod end.
6. Remove the cross tube and tie rod ends from the vehicle.
7. Mount the cross tube in a soft jaw vice.
8. Remove the hardware from the clamp on the cross tube.
9. Count the exposed threads on the tie rod end being replaced.
10. Remove the tie rod end from the cross tube.

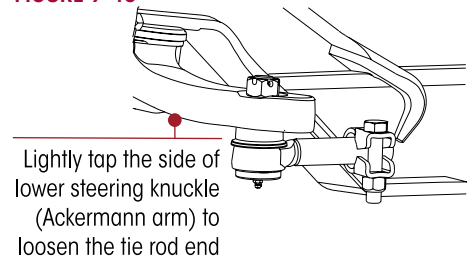
FIGURE 9-40

WARNING

DO NOT HEAT THE CROSS TUBE WITH A TORCH TO FACILITATE THE REMOVAL OF THE TIE ROD END. THE USE OF SUCH HEAT CAN ADVERSELY AFFECT THE STRENGTH OF THE CROSS TUBE. A COMPONENT DAMAGED IN THIS MANNER WILL RESULT IN LOSS OF WARRANTY, AND CAN RESULT IN THE AND LOSS OF VEHICLE CONTROL, AND POSSIBLE PERSONAL INJURY OR PROPERTY DAMAGE.

11. If the opposing tie rod end is being replaced repeat Steps 8 through 10.
12. Inspect the cross tube for dents, cracks, or thread damage. Replace the cross tube if necessary.

ASSEMBLY

1. Lubricate the new tie rod end threads with Anti-Seize.

NOTE

When installing the cross tube the thread direction of the tie rod ends are as follows:

- A right hand threaded tie rod end will be installed into the right side Ackermann arm.
- A left hand threaded tie rod end will be installed into the left side Ackermann Arm.

2. Install the new tie rod end into the cross tube, leaving the same amount of threads exposed that were counted on the failed tie rod end prior to removal.

WARNING

THE THREADED PORTION OF THE TIE ROD END MUST EXTEND PAST THE SLOTS INTO THE TIE ROD CROSS TUBE, SEE FIGURE 9-41. FAILURE TO DO SO CAN CAUSE COMPONENT DAMAGE, LOSS OF VEHICLE CONTROL AND POSSIBLE PERSONAL INJURY OR PROPERTY DAMAGE.

WARNING

IT IS CRITICAL TO CHECK THE $\frac{5}{8}$ " TIE ROD CLAMP BOLT HEAD LOCATION TO VERIFY THE CLAMP FASTENERS HAVE SUFFICIENT CLEARANCE AWAY FROM THE LOWER SHOCK MOUNT AT FULL WHEEL CUT. THE FASTENERS MUST NOT CONTACT THE LOWER SHOCK MOUNT. FAILURE TO DO SO CAN CAUSE ONE OR MORE COMPONENTS TO FAIL CAUSING LOSS OF VEHICLE CONTROL AND POSSIBLE PERSONAL INJURY OR PROPERTY DAMAGE.

3. Replace the opposing tie rod end if necessary by repeating Steps 2 and 3.

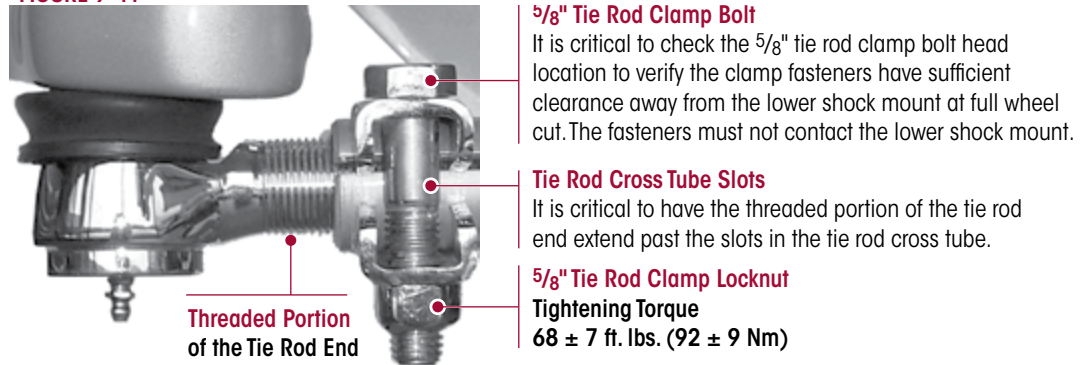
FIGURE 9-41

WARNING

DO NOT HEAT THE CROSS TUBE WITH A TORCH TO ROTATE THE CROSS TUBE IN THE TIE ROD END. THE USE OF SUCH HEAT CAN ADVERSELY AFFECT THE STRENGTH OF THE CROSS TUBE. A COMPONENT DAMAGED IN THIS MANNER WILL RESULT IN LOSS OF WARRANTY, AND CAN RESULT IN THE LOSS OF VEHICLE CONTROL, AND POSSIBLE PERSONAL INJURY OR PROPERTY DAMAGE.

4. It is critical that the cross tube rotate in the opposing tie rod end, even if it is not replaced.
5. Install the tie rod end into the lower steering knuckle.
6. Tighten the castle nuts to  185 foot pounds (251 Nm) torque, then rotate the castle nut to the next castle slot and install cotter pin.
7. Grease the tie rod ends. Refer to the Lubrication Chart for required lubricant in the Preventive Maintenance Section of this publication.
8. Set the toe, refer to the Toe Adjustment Procedure in the Alignment & Adjustments Section in this publication.

AIR DISC BRAKES

Brake components are not supplied by Hendrickson for aftermarket service purposes. For more information and assistance with service, maintenance and rebuild instructions on these components, refer to component manufacturers



SECTION 10

Front Wheel Alignment Specifications

SOFTEK for Lion8 Model Trucks

FRONT SYSTEM SUSPENSION ALIGNMENT SPECIFICATION

CAMBER ¹	DESIGN SPECIFICATION	RANGE	
		MINIMUM	MAXIMUM
LEFT	0.00° ± 1.0°	-1.0°	+1.0°
RIGHT	-0.25° ± 1.0°	-1.25°	+0.75°
CROSS	Max 2.0°	—	—

CAMBER NOTES:

- The camber angle is not adjustable. Do not bend axle or otherwise try to adjust camber. If found out of specification, notify Hendrickson Tech Services for further information.

CASTER ^{1,2}	DESIGN SPECIFICATION	RANGE	
		MINIMUM	MAXIMUM
LEFT	4.0° ± 1°	+3.0°	+5.0°
RIGHT	4.0° ± 1°	+3.0°	+5.0°
CROSS ³	Max 1.0°	—	—

CASTER NOTES:

- Caster is determined with the vehicle at rated load for mechanical suspension systems. It is critical that the vehicle front and rear ride height is within specifications prior to performing a caster measurement or adjustment. See Hendrickson ride height specifications and procedure.
- In most cases actual vehicle caster is defined with the frame rails at zero slope. Refer to the vehicle manufacturer's specifications for correct frame rail slope. (Both the alignment surface and the vehicle's frame rails should be level during execution of alignment procedures). For vehicles with a positive frame rake (higher in rear) add the frame slope (in degrees) to the caster reading to determine true vehicle caster.
- The Cross caster angle is not adjustable – DO NOT** bend axle or otherwise try to adjust cross caster. If found out of specifications notify Hendrickson Tech Services for further information. Changes to caster can be attained by using caster shims as provided by the vehicle manufacturer or chassis and body manufacturer. Caster shims must match, side to side, to reduce uneven loading to the suspension components. The use of two different angle caster shims will not correct cross caster.
- Example of **caster adjustment**: 2.5° RH/3° LH, would require one, 1.0 shim on each side to increase caster and achieve 3.50° RH/4.00° LH, which is in specification. Do not attempt to use uneven shims.

Hendrickson recommends following TMC² practices:

	DESIGN SPECIFICATION ¹	RANGE	
		MINIMUM	MAXIMUM
TOTAL TOE ²	1/16" ± 1/32" (0.06" ± 0.03")	1/32" (0.03")	3/32" (0.09")

TOE-IN NOTES:

- Toe-in is to be set and adjusted in the normal vehicle unladed configuration. Actual vehicle curb weight on the ground. Toe should be checked at the tires front and rear tread center, at a distance above ground equal to the tire's rolling radius.
- In most instances total toe is set by the vehicle manufacturer or body builder. Consult the vehicle manufacturer for specifications.

SECTION 11 Torque Specifications

Hendrickson Recommended Torque Values
Provided in Foot Pounds and in (Nm)

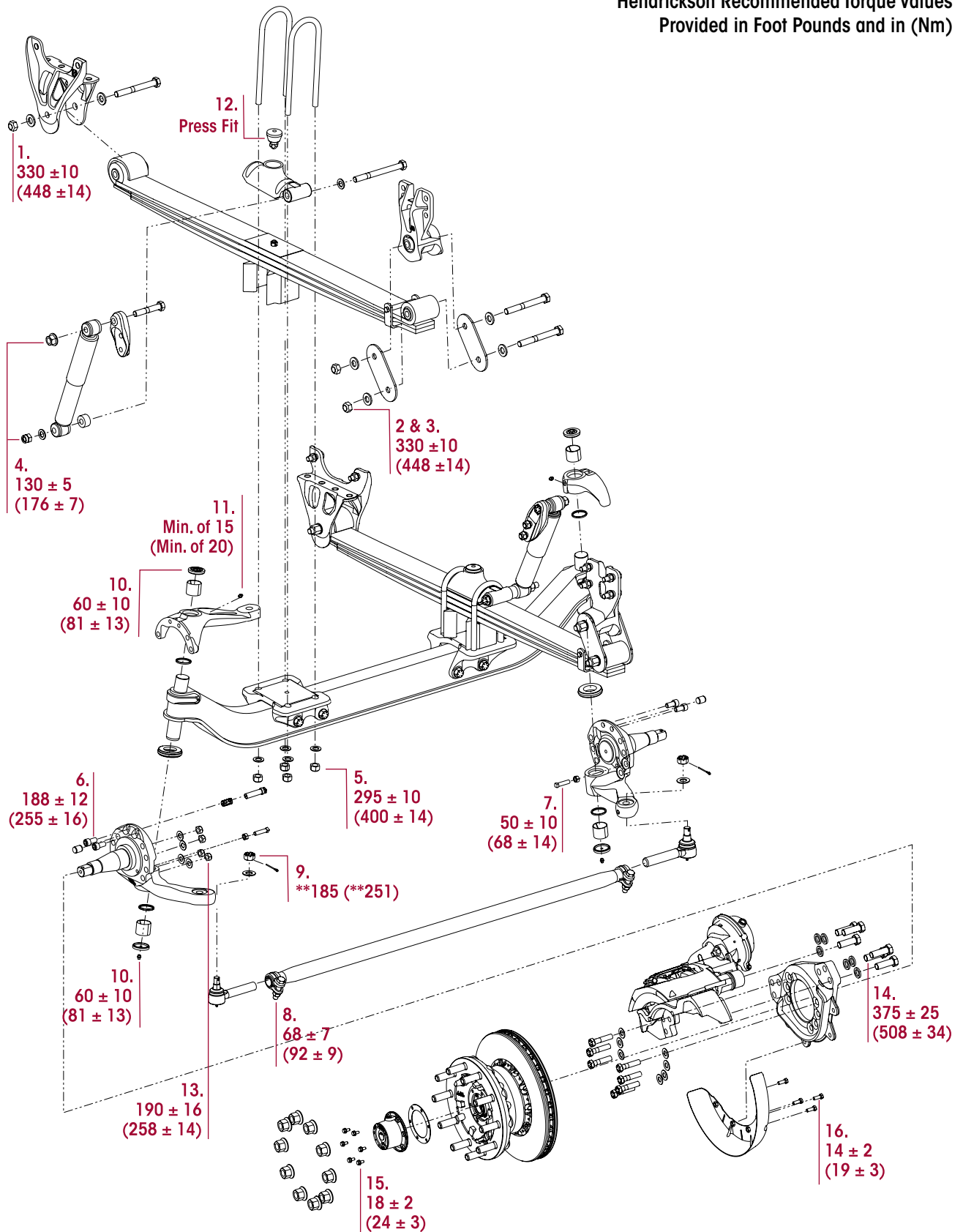



SOFTEK WITH STEERTEK NXT AXLE

HENDRICKSON RECOMMENDED TORQUE SPECIFICATIONS

NO.	COMPONENT	FASTENERS		TORQUE VALUE	
		QTY.	SIZE	FOOT POUNDS	NM
1	Front Frame Hanger to Front Leaf Spring Eye	2	¾"	330 ± 10	448 ± 14
2	Rear Shackle Bracket to Shackle Plate	2	¾"	330 ± 10	448 ± 14
3	Rear Shackle Bracket to Spring Eye	2	¾"	330 ± 10	448 ± 14
4	Upper and Lower Shock Eye	2	¾"	130 ± 5	176 ± 7
5	Clamp Group Hardware	8	¾"	295 ± 10	400 ± 14
<p>⚠ WARNING ENSURE CLAMP GROUP IS ALIGNED PROPERLY PRIOR TO TIGHTENING HARDWARE. FAILURE TO DO SO CAN CAUSE LOSS OF VEHICLE CONTROL, PROPERTY DAMAGE OR PERSONAL INJURY.</p>					
6	Knuckle Attachment Bolt (Socket Head Cap Screw)	4	⅝"	188 ± 12	255 ± 16
7	Knuckle / Axle Wheel Stop Bolt	2	½" Jam Nut	50 ± 10	68 ± 14
8	Tie Rod Tube to Tie Rod Ends	2	⅝"	68 ± 7	92 ± 9
9	Tie Rod Ends to Lower Steering Knuckle	2	⅞" Castle Nut	**185	**251
10	Grease Cap Assembly, Upper and Lower	4	½"	60 ± 10	81 ± 13
11	Grease Zerk	2		Minimum of 15	Minimum of 20
12	Rubber Axle Stop	2	—	Press Fit	
13	Torque Plate Mounting Fasteners	2	⅝"	190 ± 16	258 ± 14
14	Caliper Assembly	12	M20	375 ± 25	508 ± 34
15	Hub Cap Fasteners	12	⅝"	18 ± 2	24 ± 3
16	Dust Shield Fasteners	8	⅜"	14 ± 2	19 ± 3

• All hardware ¼" and greater is Grade 8 with no additional lubrication.
Frame mount hardware in most cases are Huck style fasteners supplied by the OEM.

NOTE: * All hardware information in the matrix denotes recommended torques for fasteners originally supplied by the vehicle manufacturer. If Hendrickson supplied fasteners are used, tighten to Hendrickson torque values, if non Hendrickson fasteners are used, follow torque specifications listed in the vehicle manufacturer's service manual. Hendrickson is not responsible for maintaining vehicle manufacturer's torque values.

** Torque to 185 foot pounds (251 Nm), advance nut to next hex face to install cotter pin. DO NOT back off nut for cotter pin installation.



SECTION 12

Troubleshooting Guide

SOFTEK for Lion8 Model Trucks

TROUBLESHOOTING GUIDE		
CONDITION	POSSIBLE CAUSE	CORRECTION
Worn or damaged kingpins and kingpin bushings	Dirt in system– contaminated lubricant	Polish and inspect kingpin, replace bushing and seals, then follow specified lubrication procedures
	Incorrect lubricant	Lubricate axle with specified lubricant
	Axle not lubricated at scheduled frequency	Lubricant axle at scheduled frequency
	Incorrect lubrication procedures	Use correct lubrication procedures
	Lubrication interval not compatible with operating conditions	Change lubrication interval to match operating conditions
	Worn or missing seals	Replace worn or missing seals
Vibration or shimmy of front axle during operation	Caster out of specification	Set proper ride height then adjust caster to specification
	Wheels and/or tires out of balance	Balance or replace wheels and/or tires
	Worn shock absorbers	Replace shock absorbers
	Worn thrust washers (if equipped) and rear hanger clamps	Replace thrust washers (if equipped) and rear hanger clamps
	Broken engine mount	Replace engine mount
	Wheel bearing adjustment	Adjust wheel bearing to the vehicle manufacturers specifications.
Excessive wear on tires or uneven tire tread wear	Tires have incorrect air pressure	Adjust tire pressure to manufacturer's specification.
	Tires out of balance	Balance or replace tires
	Incorrect tandem axle alignment	Align tandem axles
	Incorrect toe setting	Adjust toe-in to manufacturer's specification
	Incorrect steering arm geometry	Repair steering system as necessary
	Worn kingpin bushings	Replace kingpin bushings
	Excessive wheel bearing end play	Check specified wheel nut torque, replace worn or damaged wheel bearings
	Wheel bearing adjustment	Adjust wheel bearing to the vehicle manufacturers specifications.
Vehicle is hard to steer	Low pressure in the power steering system	Repair power steering system
	Steering linkage needs lubrication	Lubricate steering linkage
	Steering knuckles are binding	Check vertical clearance
	Incorrect steering arm geometry	Repair steering system as necessary
	Caster out of specification	Adjust caster to specification applicable
	Tie rod ends hard to move	Replace tie rod ends
	Worn thrust bearing	Replace thrust bearing
	Steering gear box internal problem	Perform steering gear trouble shooting procedures per steering gear manufacturing guidelines.



SOFTEK for Lion8 Model Trucks

TROUBLESHOOTING GUIDE

CONDITION	POSSIBLE CAUSE	CORRECTION
Tie rod ends are worn and require replacement	Tie rod ends need lubrication	Lubricate tie rod end. Make sure lubrication schedule is followed.
	Severe operating conditions	Increase frequency of inspection and lubrication intervals
	Damaged boot on tie rod end	Replace tie rod end
Bent or broken cross tube, tie rod end ball stud or tie rod end NOTE: Damaged components require replacement	Pump/gear relief valve pressure setting exceeds system specifications	Adjust power steering system to manufacturer's specified pressure
	Steering gear poppets improperly set or malfunctioning	Check for proper operation or adjust poppets to OEM specifications
	Axle stops improperly set	Set axle stops to OEM specifications
	Severe duty cycle service	Increase frequency of inspection and lubrication intervals
Worn or broken steering ball stud	Drag link fasteners lightened past specified torque	Tighten drag link fasteners to the specified torque
	Lack of lubrication or incorrect lubricant	Lubricate linkage with specified lubricant
	Power steering stops out of adjustment	Adjust steering stops to OEM specifications
Suspension has harsh or bumpy ride	Broken or worn leaf spring	Replace leaf spring assembly
	Front suspension overloaded	Redistribute steer axle load
Restricted steering radius	Steering stops not adjusted correctly	Adjust steering stops to achieve correct wheel cut
Vehicle leans	Suspension is not torqued correctly at installation	Perform spring eye re-torque procedure. See Torque Specification Section of this publication
	Leaf spring broken	Replace leaf spring
	Excessive weight bias	Contact the vehicle manufacturer or Hendrickson Tech Services
Vehicle wanders	Caster out of specifications	Set proper ride height then adjust caster to specification
	Incorrect toe setting	Adjust toe to specification
	Air in the power steering system	Remove air from the power steering systems
	Rear ride height out of adjustment	Adjust ride height to specification

SECTION 13

Reference Material

This technical publication covers Hendrickson Truck Suspension's recommended procedures for our parts/products. Other components play a major role in overall performance and Hendrickson recommends you follow the specific vehicle manufacturer's recommendation for care and maintenance. Some recommended procedures have been developed by The Technology & Maintenance Council (TMC) and Hendrickson supports these recommendations. We have compiled a list of these below.

■ TMC

To obtain copies of the following RPs, videos, or charts, contact TMC at:

TMC / ATA	Phone: 703-838-1763
2200 Mill Road	website: tmc.truckline.com
Alexandria, VA 22314	online ordering: www.truckline.com/store

Important References

TMC RP 214B	Tire/Wheel End Balance and Runout
TMC RP 216	Radial Tire Conditions Analysis Guide
TMC RP 219A	Radial Tire Wear Conditions and Causes
TMC RP 222A	User's Guide To Wheels and Rims
TMC RP 230	Tire Test Procedures for Tread wear, Serviceability, and Fuel Economy
TMC RP 514	Pre-Alignment Inspection
TMC RP 618	Wheel Bearing Adjustment Procedure
TMC RP 620B	Front End Alignment Steering Geometry
TMC RP 708A	Trailer Axle Alignment
TMC RP 642	Guidelines For Total Vehicle Alignment
TMC RP 644	Wheel End Conditions Analysis Guide
TMC RP 645	Tie Rod End Inspection and Maintenance Procedure

Videos

TMC T0326	Wheel End Maintenance
TMC T0372	Tire Pre-Trip Inspection Guidelines

Other

TMC T0400	Wheel bearing Adjustment Procedure Wall Chart
-----------	---



Actual product performance may vary depending upon vehicle configuration, operation, service and other factors.
All applications must comply with applicable Hendrickson specifications and must be approved by the respective vehicle manufacturer with the vehicle in its original, as-built configuration.
Contact Hendrickson for additional details regarding specifications, applications, capacities, and operation, service and maintenance instructions.

*Call Hendrickson at **1.866.755.5968** (toll-free) or **1.630.910.2800** for additional information.*



www.hendrickson-intl.com

TRUCK COMMERCIAL VEHICLE SYSTEMS
800 South Frontage Road
Woodridge, IL 60517-4904 USA
1.866.755.5968 (Toll-free U.S. and Canada)
1.630.910.2800 (Outside U.S. and Canada)
Fax 1.630.910.2899

17730-332 Rev A 05-20

© 2020 Hendrickson USA, L.L.C. All Rights Reserved. All trademarks shown are owned by Hendrickson USA, L.L.C., or one of the affiliates, in one or more countries.
Information contained in this literature was accurate at the time of publication. Product changes may have been made after the copyright date that are not reflected.

Printed in United States of America